



(11) **EP 1 753 084 A3**

(12) **EUROPEAN PATENT APPLICATION**

(88) Date of publication A3:
27.02.2008 Bulletin 2008/09

(51) Int Cl.:
H01Q 9/04 ^(2006.01) **H01Q 9/16** ^(2006.01)
H01Q 9/30 ^(2006.01) **H01Q 13/02** ^(2006.01)
H01Q 13/06 ^(2006.01) **H01Q 13/20** ^(2006.01)
H01Q 13/22 ^(2006.01)

(43) Date of publication A2:
14.02.2007 Bulletin 2007/07

(21) Application number: **06123190.8**

(22) Date of filing: **04.04.2002**

(84) Designated Contracting States:
AT BE CH CY DE DK ES FI FR GB GR IE IT LI LT LU MC NL PT SE TR

(71) Applicant: **Kyocera Wireless Corp.**
San Diego, CA 92121 (US)

(30) Priority: **11.04.2001 US 283093 P**
13.07.2001 US 904631
24.07.2001 US 912753
08.08.2001 US 927732
10.08.2001 US 927126

(72) Inventors:
• **Toncich, Stanley Slavko**
San Diego, CA 92131 (US)
• **Tran, Allen**
San Diego, CA 92130 (US)

(62) Document number(s) of the earlier application(s) in accordance with Art. 76 EPC:
02718438.1 / 1 384 285

(74) Representative: **Viering, Jentschura & Partner**
Postfach 22 14 43
80504 München (DE)

(54) **Ferroelectric slot antenna**

(57) A family of FE dielectric-tuned slot antennas and a method for frequency tuning a wireless communications antenna are provided. The method comprises: forming a radiator (504); forming a dielectric with ferroelectric material proximate to the radiator (506) forming a counterpoise (502); forming a slot (508); applying a voltage to the ferroelectric material; in response to applying the voltage, generating a dielectric constant; and, in response to the dielectric constant, communicating elec-

tromagnetic fields at a resonant frequency. Some aspects of the method further comprise: varying the applied voltage; and, modifying the resonant frequency in response to changes in the applied voltage. Modifying the resonant frequency includes forming an antenna with a variable operating frequency responsive to the applied voltage. Alternately stated, forming an antenna with a variable operating frequency includes forming an antenna with a predetermined fixed characteristic impedance, independent of the resonant frequency.

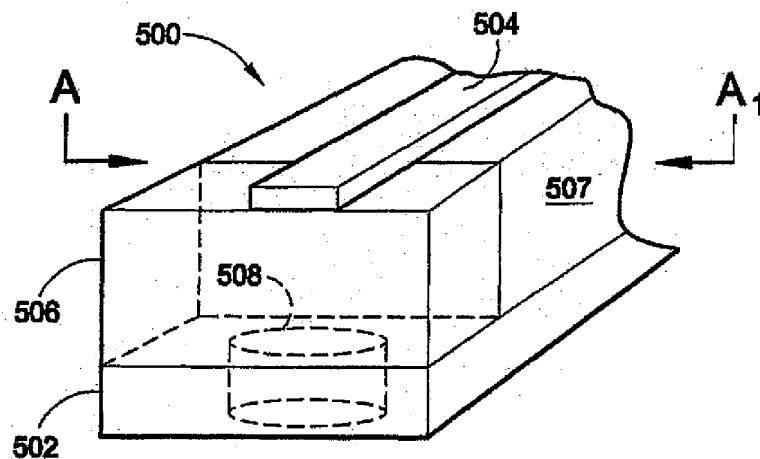

FIG. 5a

EP 1 753 084 A3



DOCUMENTS CONSIDERED TO BE RELEVANT			
Category	Citation of document with indication, where appropriate, of relevant passages	Relevant to claim	CLASSIFICATION OF THE APPLICATION (IPC)
X	US 5 617 104 A (DAS SATYENDRANATH) 1 April 1997 (1997-04-01)	1-3,5-7	INV. H01Q9/04 H01Q9/16 H01Q9/30 H01Q13/02 H01Q13/06 H01Q13/20 H01Q13/22
Y	* column 8, line 31 - column 9, line 25; figures 11-13 *	8-10	
Y	----- US 3 949 405 A (ROQUENCOURT JACQUES) 6 April 1976 (1976-04-06) * column 1, line 5 - line 17 * * column 2, line 48 - line 53; figure 2 *	8-10	
Y	----- GB 2 251 520 A (THOMSON CSF [FR]) 8 July 1992 (1992-07-08) * page 4, line 24 - page 5, line 15; figures 1,2 *	8	
X	----- US 5 583 524 A (MILROY WILLIAM W [US]) 10 December 1996 (1996-12-10) * column 12, line 5 - line 49; figures 30B,30C *	1,8	
X	----- WO 00/79645 A (ERICSSON TELEFON AB L M) 28 December 2000 (2000-12-28) * page 4, line 9 - page 5, line 17; figure 1 * * page 8, lines 4-25 *	1	
A	----- DE 12 30 468 B (PHILIPS PATENTVERWALTUNG) 15 December 1966 (1966-12-15) * column 3, line 31 - column 4, line 20; figures 1-3 *	8,9	H01Q
		----- -/--	
The present search report has been drawn up for all claims			
Place of search Munich		Date of completion of the search 16 January 2008	Examiner LA CASTA MUNOA, S
CATEGORY OF CITED DOCUMENTS X : particularly relevant if taken alone Y : particularly relevant if combined with another document of the same category A : technological background O : non-written disclosure P : intermediate document		T : theory or principle underlying the invention E : earlier patent document, but published on, or after the filing date D : document cited in the application L : document cited for other reasons ----- & : member of the same patent family, corresponding document	

5
EPO FORM 1503 03.82 (P04C01)



DOCUMENTS CONSIDERED TO BE RELEVANT			
Category	Citation of document with indication, where appropriate, of relevant passages	Relevant to claim	CLASSIFICATION OF THE APPLICATION (IPC)
A	VARADAN V K ET AL: "DESIGN AND DEVELOPMENT OF ELECTRONICALLY TUNABLE MICROSTRIP ANTENNAS" SMART MATERIALS AND STRUCTURES, IOP PUBLISHING LTD., BRISTOL, GB, vol. 8, no. 2, April 1999 (1999-04), pages 238-242, XP000873947 ISSN: 0964-1726 * the whole document * -----	1-10	
			TECHNICAL FIELDS SEARCHED (IPC)
The present search report has been drawn up for all claims			
Place of search Munich		Date of completion of the search 16 January 2008	Examiner LA CASTA MUNOA, S
CATEGORY OF CITED DOCUMENTS X : particularly relevant if taken alone Y : particularly relevant if combined with another document of the same category A : technological background O : non-written disclosure P : intermediate document T : theory or principle underlying the invention E : earlier patent document, but published on, or after the filing date D : document cited in the application L : document cited for other reasons & : member of the same patent family, corresponding document			

5
EPO FORM 1508 03 82 (P04C01)

ANNEX TO THE EUROPEAN SEARCH REPORT
ON EUROPEAN PATENT APPLICATION NO.

EP 06 12 3190

This annex lists the patent family members relating to the patent documents cited in the above-mentioned European search report. The members are as contained in the European Patent Office EDP file on
The European Patent Office is in no way liable for these particulars which are merely given for the purpose of information.

16-01-2008

Patent document cited in search report		Publication date	Patent family member(s)	Publication date
US 5617104	A	01-04-1997	NONE	
US 3949405	A	06-04-1976	FR 2255715 A1 GB 1477700 A	18-07-1975 22-06-1977
GB 2251520	A	08-07-1992	DE 4120521 A1 FR 2677814 A1 IT 1249889 B SE 9101892 A	03-09-1992 18-12-1992 30-03-1995 15-01-1993
US 5583524	A	10-12-1996	NONE	
WO 0079645	A	28-12-2000	AU 5863000 A EP 1196962 A1 SE 516235 C2 SE 9902337 A US 6335710 B1	09-01-2001 17-04-2002 03-12-2001 19-12-2000 01-01-2002
DE 1230468	B	15-12-1966	NONE	

EPO FORM P0459

For more details about this annex : see Official Journal of the European Patent Office, No. 12/82