

(19)



(11)

EP 1 764 319 A1

(12)

EUROPEAN PATENT APPLICATION

(43) Date of publication:

21.03.2007 Bulletin 2007/12

(51) Int Cl.:

B65G 51/03 (2006.01)

E01B 25/10 (2006.01)

(21) Application number: **06460031.5**

(22) Date of filing: **12.09.2006**

(84) Designated Contracting States:

**AT BE BG CH CY CZ DE DK EE ES FI FR GB GR
HU IE IS IT LI LT LU LV MC NL PL PT RO SE SI
SK TR**

Designated Extension States:

AL BA HR MK YU

(71) Applicant: **Tabaszewska, Maria**

05-090 Raszyn-Rybie (PL)

(72) Inventor: **Tabaszewska, Maria**

05-090 Raszyn-Rybie (PL)

(30) Priority: **16.09.2005 PL 37710505**

(54) **Air track**

(57) The subject of the invention is an air track of high load capacity comprised of a double aluminium pipe (1) placed above a long rigid support (2) and of a glider (4)

fit with an element (5) of considerable mass if compared to the glider's mass. The double pipe (1) of the track is pressed down to the support (2) through the medium of springs (3).

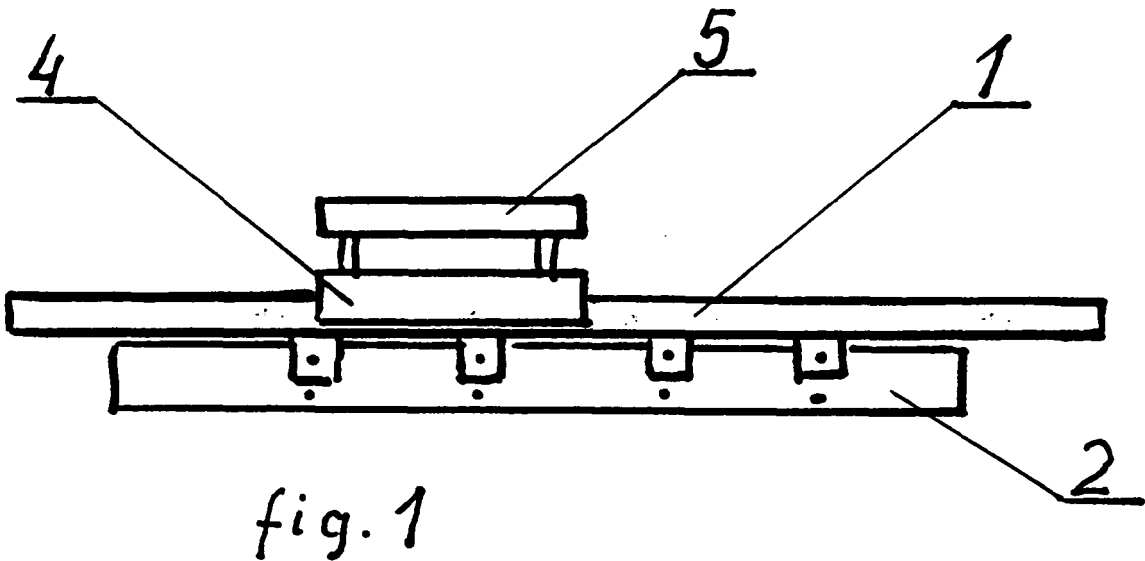

EP 1 764 319 A1

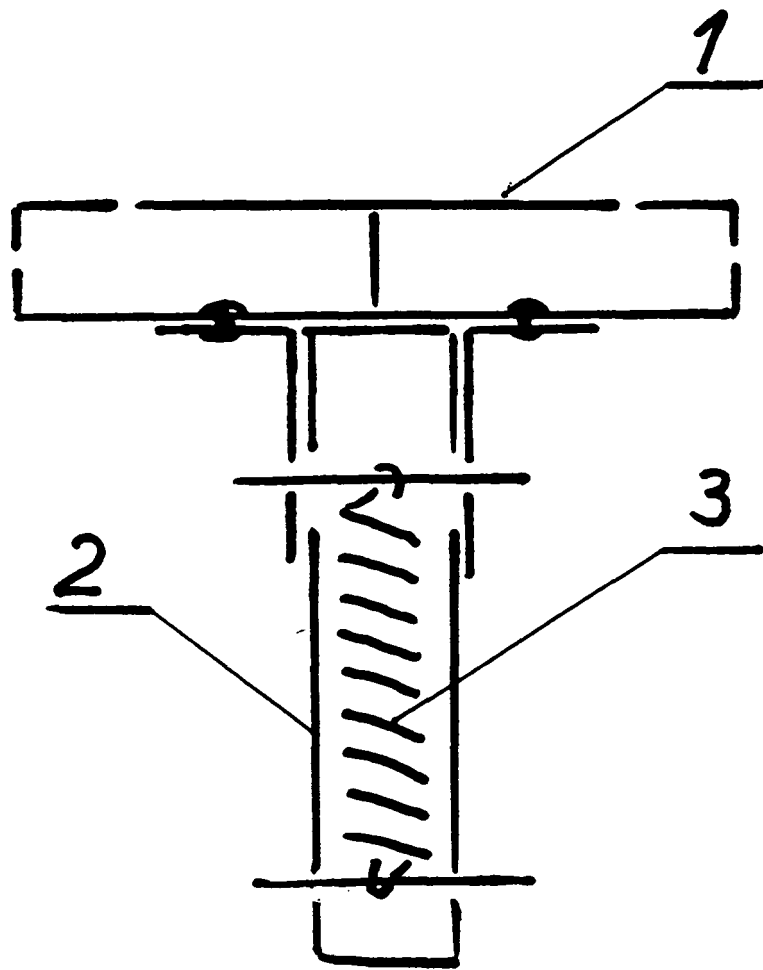

fig.2

Description

Field of technology

[0001] The subject of the invention is the air track, i.e. a device for lifting the bodies of known weights over the ground through the medium of compressed air.

[0002] The subject of the invention is intended to lift and transport the bodies of considerable weight with very low resistance to motion.

[0003] The subject of the invention may be used wherever a required information might be an observation of motion of the bodies, not interfered by friction to the ground.

Prior art

[0004] The air tracks comprised of the pipe with aeration vents exhausting jets of compressed air lifting a glider are known. The pipes have various cross-sections: round, square, triangular, or rectangular. The glider's shape fits that of the pipe.

[0005] To prevent the pipes from dipping with their own weight and the glider's weight, these are fastened to the rigid, long metallic element.

[0006] Known air tracks are inconvenient in use because due to the difference in temperatures of the air supplied to the pipe and the air surrounding the stiffening support, the whole appliance bends which causes unintended movements of the gliders hovering over the track.

[0007] In known air tracks a thickness of the air-cushion below whole surface of the glider is uniform and has to be considerable to diminish an influence of the air viscosity on slowing-down the glider's movement.

[0008] An inconvenience in use of known air tracks consists in that the weights hovering on the air-cushion are low because a significant part of the air escapes from below of the glider through wide gaps.

[0009] In known air tracks the forces accelerating the gliders (particularly in collisions of the gliders) are applied to the point above the glider's mass centre.

[0010] An inconvenience in use of known air tracks consists in that the glider accelerated with the force applied to the point above its mass tilts over and grinds against the track.

[0011] An inconvenience in use of known air tracks consists in that the gliders lifted on the air-cushion close to the longitudinal axis reel and grind against the track.

Substance of the invention

[0012] The substance of the invention which is the air track consisting of the double aluminium pipe with rectangular cross-section, long rigid support and the glider, is an application of the springs that press down the track pipe to the support, which enables the pipe to move with regard to the support.

[0013] In the solution according to the invention the

height of lateral gaps formed by the glider and the track pipe and filled with compressed air is less than 0.25 of the track width, and the width of each of lateral gaps filled with compressed air and formed by the glider and the track pipe is less than 0.2 mm.

[0014] In the solution according to the invention the glider is fit with the element of considerable mass if compared to the glider's mass and placed so that the glider's mass centre is above the track's surface.

[0015] In the solution according to the invention the holes in the top surface of the pipe are placed close to the track pipe edges, and the pipe central part which is 70% of the track pipe total top surface has no holes, and the double track pipe and support are made from double aluminium pipe of rectangular cross-section which is used for measuring staff with outer width of 90.5 mm and thickness of 18 mm.

Virtues of the invention

[0016] A virtue of the solution according to the invention which is the air track consisting of the double aluminium pipe of rectangular cross-section, long rigid support and the glider is in that because of a possibility for the track pipe to move above the support, the track pipe reflects the support's shape and does not bend while influenced by a difference in temperatures of the air conducted from a compressor toward the track pipe and that of the air surrounding the support.

[0017] A virtue of the solution according to the invention which is the air track consisting of the double aluminium pipe of rectangular cross-section, long rigid support and the glider is in that the lateral gaps filled with compressed air and formed by the track pipe and the glider, because of that they have very low width, less than 0.2 mm each, they prevent the air from escaping from beneath the glider, which makes possible to burden the glider with additional weight, and slight height of lateral gaps, lesser than 0.25 of the track width, does not increase meaningfully the resistance to motion.

[0018] A virtue of the solution according to the invention which is the air track consisting of the double aluminium pipe of rectangular cross-section, long rigid support and the glider is in that the air which gets out of the holes situated close to the track pipe edges, far from the track longitudinal axis, lifts the glider and additionally prevents it from reeling and grinding against the track pipe.

[0019] A virtue of the solution according to the invention which is the air track consisting of the double aluminium pipe of rectangular cross-section, long rigid support and the glider is in advantageous application of easily accessible, precisely manufactured double aluminium pipes of rectangular shape which are used for measuring staff.

Example of accomplishment of the invention

[0020] The subject of the invention is represented in

the example of accomplishment on the drawing where fig. 1 shows the lateral view of the air track, fig. 2 shows the cross-section of the air track without the glider, and fig. 3 shows the cross-section of the air track.

[0021] Following the labels on the drawing the air track consists of the double aluminium pipe (1) of rectangular cross-section, long rigid support (2) and the glider (4) fit with the element (5) of considerable mass if compared to the glider's (4) mass and placed so that the glider's (4) mass centre is above the track's (1) surface.

[0022] The springs (3) press down the track pipe (1) to the support (2). Lateral gaps filled with compressed air and formed by the glider (4) and the track pipe (1) are of height lesser than 0.25 of the track pipe (1) width, and the width of each of lateral gaps formed by the glider (4) and the track pipe (1) is less than 0.2 mm. The holes in the top surface of the pipe (1) are placed close to the edges of the track pipe (1), and central part of the pipe (1) which is 70% of the track pipe (1) total top surface has no holes.

[0023] The double track pipe (1) and the support (2) are advantageously made from double aluminium pipe of rectangular cross-section which is used for measuring staff with outer width of 90.5 mm and thickness of 18 mm.

Claims

1. The air track consisting of the double aluminium pipe of rectangular cross-section, the support and the glider **characterised in that** the track pipe (1) is pressed down through the medium of the springs (3) to the support (2) which enables it to move with regard to the support (2).
2. The air track consisting of the double aluminium pipe of rectangular cross-section, the support and the glider **characterised in that** the lateral gaps filled with compressed air and formed by the glider (4) and the track pipe (1) are of height lesser than 0.25 of the track pipe (1) width.
3. The air track consisting of the double aluminium pipe of rectangular cross-section, the support and the glider **characterised in that** the lateral gaps filled with compressed air and formed by the glider (4) and the track pipe (1) are of width lesser than 0.2 mm.
4. The air track consisting of the double aluminium pipe of rectangular cross-section, the support and the glider **characterised in that** the glider (4) is fit with the element (5) of considerable mass if compared to the glider's (4) mass and placed so that the glider's (4) mass centre is above the surface of the track (1).
5. The air track consisting of the double aluminium pipe of rectangular cross-section, the support and the glider **characterised in that** the orifices in the top

surface of the pipe (1) are placed close to the edges of the track pipe (1) and central part of the pipe (1) which is 70% of the track pipe (1) total top surface has no orifices.

6. The air track **characterised in that** the double track pipe (1) and the support (2) are advantageously made from double aluminium pipe of rectangular cross-section which is used for measuring staff with outer width of 90.5 mm and a thickness of 18 mm.

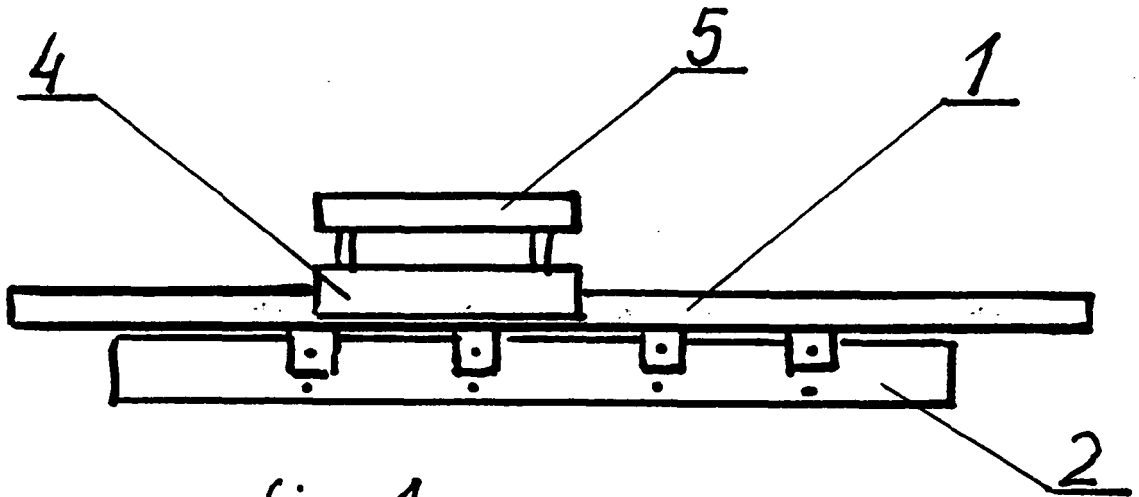

fig. 1

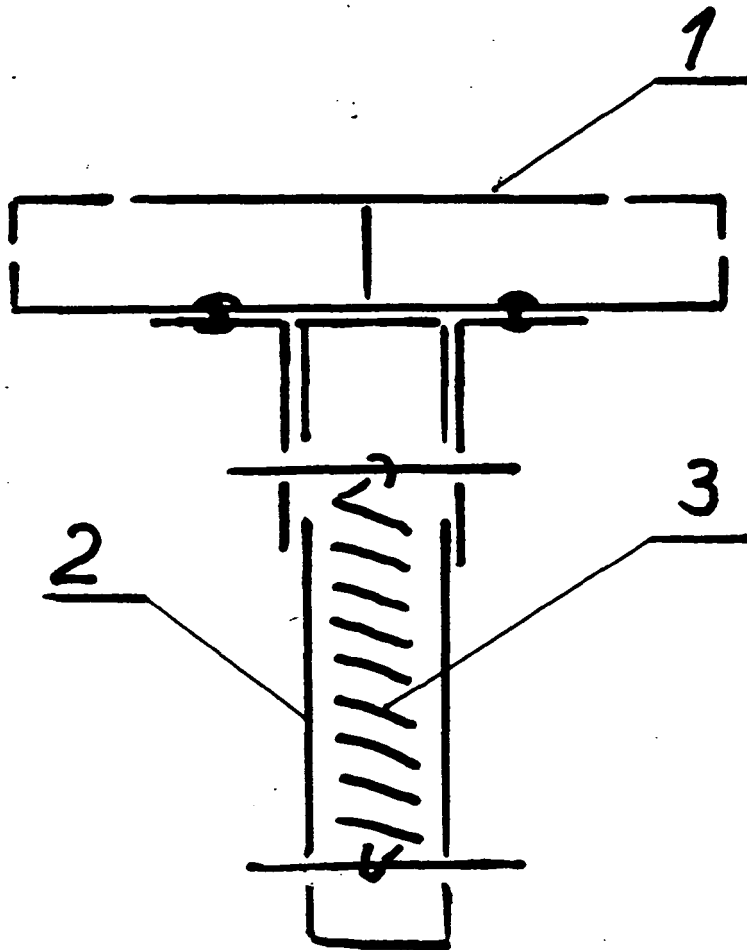

fig. 2

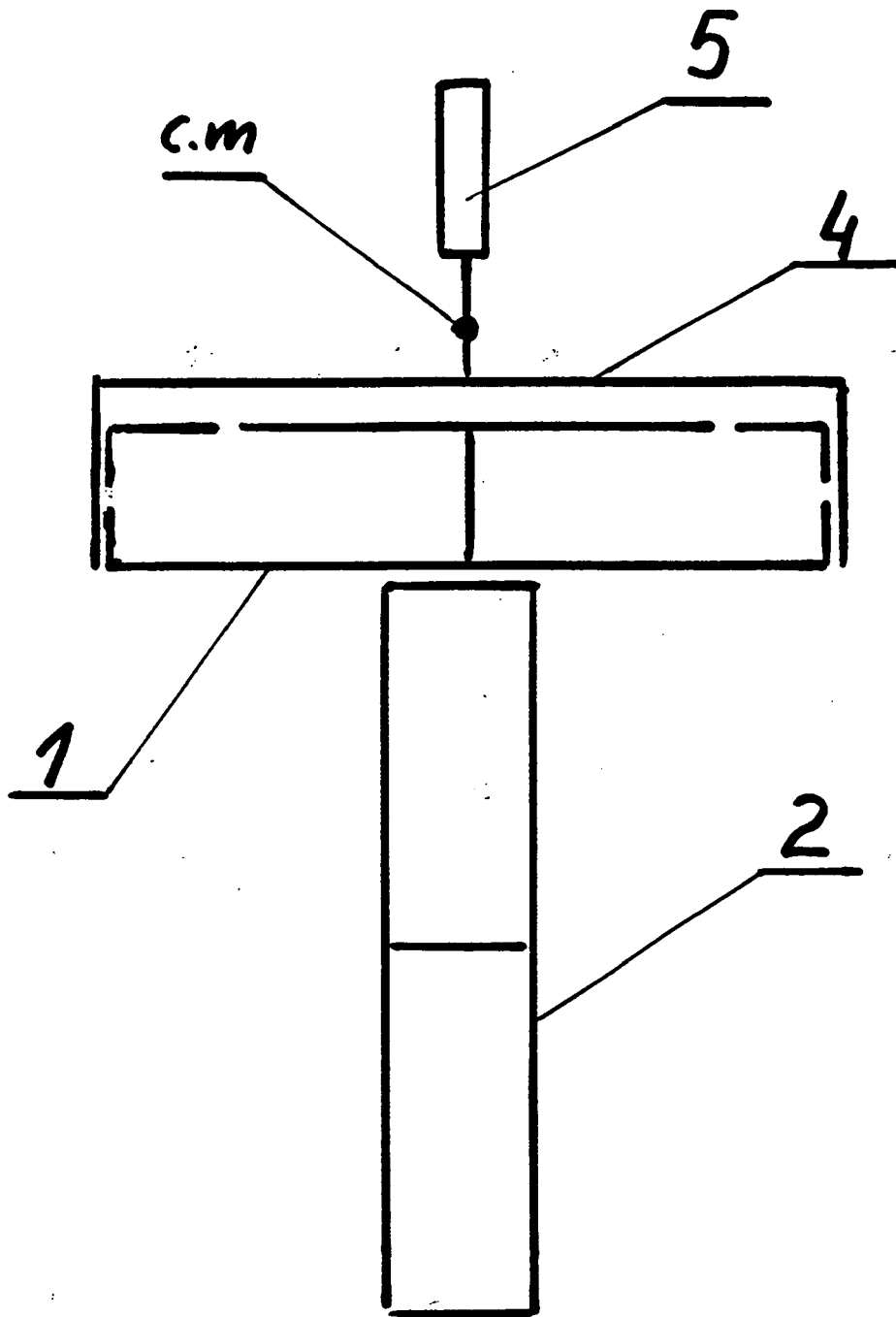

fig. 3



DOCUMENTS CONSIDERED TO BE RELEVANT			
Category	Citation of document with indication, where appropriate, of relevant passages	Relevant to claim	CLASSIFICATION OF THE APPLICATION (IPC)
X	FR 2 689 077 A (MAGAR HUBERT [FR]) 1 October 1993 (1993-10-01)	2,3,6	INV. B65G51/03 E01B25/10
Y	* abstract; figure 1 *	4,5	
Y	----- US 4 718 539 A (FUKUWATARI ICHIRO [JP] ET AL) 12 January 1988 (1988-01-12) * column 2, lines 50-59; figures 1-6 *	4,5	
Y	----- US 4 714 155 A (WATANABE SEIJI [JP] ET AL) 22 December 1987 (1987-12-22)	4,5	
A	* column 2, lines 62-67; figures 1-3 *	1	
A	----- DE 23 07 644 A1 (FISCHER ARTUR) 22 August 1974 (1974-08-22) * figure 1 *	2-6	
A	----- US 3 209 702 A (EBERHARD LEMCKE) 5 October 1965 (1965-10-05) * column 4, lines 32-36; figures 1-3 *	1	
A	----- DE 102 39 661 A1 (WALTER BAU AG [DE]) 18 March 2004 (2004-03-18) * paragraphs [0018], [0030]; figures 1,2,7,8 *	1	
The present search report has been drawn up for all claims			TECHNICAL FIELDS SEARCHED (IPC)
			B65G B60V B61B A63H E01B
3	Place of search Munich	Date of completion of the search 4 January 2007	Examiner Garlati, Timea
CATEGORY OF CITED DOCUMENTS		T : theory or principle underlying the invention E : earlier patent document, but published on, or after the filing date D : document cited in the application L : document cited for other reasons & : member of the same patent family, corresponding document	
X : particularly relevant if taken alone Y : particularly relevant if combined with another document of the same category A : technological background O : non-written disclosure P : intermediate document			

**CLAIMS INCURRING FEES**

The present European patent application comprised at the time of filing more than ten claims.

- Only part of the claims have been paid within the prescribed time limit. The present European search report has been drawn up for the first ten claims and for those claims for which claims fees have been paid, namely claim(s):
- No claims fees have been paid within the prescribed time limit. The present European search report has been drawn up for the first ten claims.

LACK OF UNITY OF INVENTION

The Search Division considers that the present European patent application does not comply with the requirements of unity of invention and relates to several inventions or groups of inventions, namely:

see sheet B

- All further search fees have been paid within the fixed time limit. The present European search report has been drawn up for all claims.
- As all searchable claims could be searched without effort justifying an additional fee, the Search Division did not invite payment of any additional fee.
- Only part of the further search fees have been paid within the fixed time limit. The present European search report has been drawn up for those parts of the European patent application which relate to the inventions in respect of which search fees have been paid, namely claims:
- None of the further search fees have been paid within the fixed time limit. The present European search report has been drawn up for those parts of the European patent application which relate to the invention first mentioned in the claims, namely claims:



The Search Division considers that the present European patent application does not comply with the requirements of unity of invention and relates to several inventions or groups of inventions, namely:

1. claim: 1

An air track pipe where said pipe is pressed down to the support through springs according to claim 1.

2. claims: 2-3

An air track and glider with the lateral gaps between said parts being filled with compressed air according to claims 2 and 3.

3. claims: 4,5

An air track and glider, the glider being fitted with an element of considerable mass according to claim 4 and the orifices of the track pipe being located close to its edge according to claim 5.

4. claim: 6

An air track pipe used for measuring staff.

**ANNEX TO THE EUROPEAN SEARCH REPORT
ON EUROPEAN PATENT APPLICATION NO.**

EP 06 46 0031

This annex lists the patent family members relating to the patent documents cited in the above-mentioned European search report. The members are as contained in the European Patent Office EDP file on
The European Patent Office is in no way liable for these particulars which are merely given for the purpose of information.

04-01-2007

Patent document cited in search report		Publication date	Patent family member(s)	Publication date
FR 2689077	A	01-10-1993	WO 9319964 A1	14-10-1993
US 4718539	A	12-01-1988	NONE	
US 4714155	A	22-12-1987	JP 61169669 U	21-10-1986
DE 2307644	A1	22-08-1974	NONE	
US 3209702	A	05-10-1965	NONE	
DE 10239661	A1	18-03-2004	NONE	

EPO FORM P0459

For more details about this annex : see Official Journal of the European Patent Office, No. 12/82