

(19)



(11)

EP 1 772 895 A1

(12)

EUROPEAN PATENT APPLICATION

(43) Date of publication:
11.04.2007 Bulletin 2007/15

(51) Int Cl.:
H01J 49/40^(2006.01)

(21) Application number: **06026560.0**

(22) Date of filing: **22.10.2002**

(84) Designated Contracting States:
**AT BE BG CH CY CZ DE DK EE ES FI FR GB GR
IE IT LI LU MC NL PT SE SK TR**

• **Green, Martin**
Cheshire
WA14 3EE (GB)

(30) Priority: **22.10.2001 GB 0125241**
19.11.2001 GB 0127662
17.09.2002 GB 0221502

(74) Representative: **Jeffrey, Philip Michael**
Frank B. Dehn & Co.
St Bride's House
10 Salisbury Square
London EC4Y 8JD (GB)

(62) Document number(s) of the earlier application(s) in accordance with Art. 76 EPC:
02257332.3 / 1 306 881

Remarks:

This application was filed on 21 - 12 - 2006 as a divisional application to the application mentioned under INID code 62.

(71) Applicant: **Micromass UK Limited**
Manchester M22 5PP (GB)

(72) Inventors:
• **Bateman, Robert, Harold**
Cheshire
WA16 8NP (GB)

(54) **Mass spectrometer**

(57) A mass spectrometer is disclosed wherein the pusher electrode 4 of a Time of Flight mass analyser is

operated in conjunction with an ion gate 2 to ensure that low mass background or matrix ions are not injected into the drift region 5 of the mass analyser.

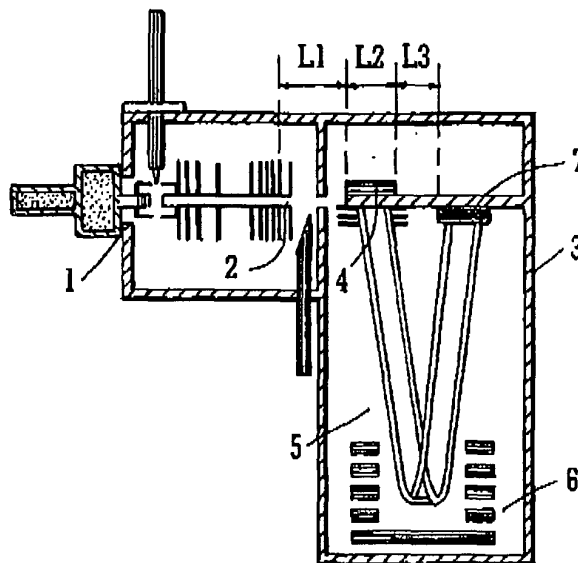

FIG. 1

EP 1 772 895 A1

Description

[0001] The present invention relates to a mass spectrometer.

[0002] A common problem with known mass spectrometers is that the largest ions in a mass spectrum may originate from chemical species (i.e. background ions) which are of no interest to the analysis. For example, the background ions may comprise solvent ions, Gas Chromatograph carrier gas ions, Chemical Ionisation reagent gas ions or air peaks from vacuum leaks. These background ions can give rise to large ion signals which unless attenuated may saturate the ion detector thereby affecting the integrity of the mass spectra produced and reducing the lifetime of the ion detector.

[0003] It is therefore desired to provide an improved mass spectrometer.

[0004] According to a first aspect of the present invention there is provided a mass spectrometer comprising :

an ion source;
 an orthogonal acceleration Time of Flight mass analyser comprising an electrode for orthogonally accelerating ions, an ion detector and a drift region therebetween;
 an ion gate upstream of the electrode; and
 control means for switching the ion gate between a first mode and a second mode, the second mode having a lower ion transmission efficiency than the first mode, wherein in a mode of operation the control means:

- (i) switches the ion gate from the first mode to the second mode at a time T_1 ; and
- (ii) causes the electrode to inject or orthogonally accelerate ions into the drift region at a later time $T_1 + \Delta T_1$;

wherein ΔT_1 is set such that ions having a mass to charge ratio \leq a value $M1$ are not substantially injected or orthogonally accelerated into the drift region by the electrode.

[0005] An advantage of the preferred embodiment is that the ion signal from intense low mass to charge ratio ions can be prevented from reaching the ion detector reducing the possibility of detector saturation and increasing the lifetime of the detector.

[0006] Preferably, ions having a mass to charge ratio \geq a value $M1'$ are substantially injected or orthogonally accelerated into said drift region by said electrode with a first transmission efficiency and ions having a mass to charge ratio in the range $M1-M1'$ are substantially injected or orthogonally accelerated into said drift region by said electrode with a second transmission efficiency lower than said first transmission efficiency, wherein $M1 < M1'$.

[0007] Preferably, $M1'$ falls within a range selected

from the group consisting of: (i) 1-50; (ii) 50-100; (iii) 100-150; (iv) 150-200; (v) 200-250; (vi) 250-300; (vii) 300-350; (viii) 350-400; (ix) 400-450; (x) 450-500; (xi) 500-550; (xii) 550-600; (xiii) 600-650; (xiv) 650-700; (xv) 700-750; (xvi) 750-800; (xvii) 800-850; (xviii) 850-900; (xix) 900-950; (xx) 950-1000; (xxi) 1000-1500; (xxii) 1500-2000; (xxiii) 2000-2500; (xxiv) 2500-3000; and (xxv) > 3000 .

[0008] After the ion gate has been switched from the first (ON) mode to the second (OFF) mode the pusher electrode is then energised after a delay time ΔT_1 , wherein ΔT_1 preferably falls within a range selected from the group consisting of: (i) 0.1-1 μ s; (ii) 1-5 μ s; (iii) 5-10 μ s; (iv) 10-15 μ s; (v) 15-20 μ s; (vi) 20-50 μ s; (vii) 50-100 μ s; (viii) 100-500 μ s; and (ix) 500-1000 μ s.

[0009] The low mass cut-off $M1$ preferably falls within a range selected from the group consisting of: (i) 1-5; (ii) 5-10; (iii) 10-15; (iv) 15-20; (v) 20-25; (vi) 25-30; (vii) 30-35; (viii) 35-40; (ix) 40-45; (x) 45-50; (xi) 50-55; (xii) 55-60; (xiii) 60-65; (xiv) 65-70; (xv) 70-75; (xvi) 75-100; (xvii) 100-150; (xviii) 150-200; (xix) 200-250; (xx) 250-300; (xxi) 300-350; (xxii) 350-400; (xxiii) 400-450; (xxiv) 450-500; (xxv) 500-550; (xxvi) 550-600; (xxvii) 600-650; (xxviii) 650-700; (xxix) 700-750; (xxx) 750-800; (xxxi) 800-850; (xxxii) 850-900; (xxxiii) 900-950; (xxxiv) 950-1000; and (xxxv) > 1000 .

[0010] Further preferably $M1$ is selected from the group consisting of: (i) 4; (ii) 17; (iii) 18; (iv) 28; (v) 29; (vi) 40; (vii) 41; (viii) 93; (ix) 139; (x) 185; (xi) 379; and (xii) 568.

[0011] Preferably, immediately after said control means has caused said electrode to inject or orthogonally accelerate ions into said drift region at time $T_1 + \Delta T_1$ said control means switches said ion gate from said second mode to said first mode.

[0012] According to a second aspect of the present invention, there is provided a mass spectrometer comprising:

an ion source;
 an orthogonal acceleration Time of Flight mass analyser comprising an electrode for orthogonally accelerating ions, an ion detector and a drift region therebetween;
 an ion gate upstream of the electrode; and
 control means for switching the ion gate between a first mode and a second mode, the second mode having a lower ion transmission efficiency than the first mode, wherein in a mode of operation the control means:

- (i) switches the ion gate from the second mode to the first mode at a time T_2 ; and
- (ii) causes the electrode to inject or orthogonally accelerate ions into the drift region at a later time $T_2 + \Delta T_2$;

wherein ΔT_2 is set such that ions having a mass to

charge ratio \geq a value M3 are not substantially injected or orthogonally accelerated into the drift region by the electrode.

[0013] The embodiment enables high mass to charge ratio ions to be excluded from being orthogonally accelerated or otherwise injected into the drift region of the Time of Flight mass analyser.

[0014] Preferably, ions having a mass to charge ratio \leq a value M3' are substantially injected or orthogonally accelerated into said drift region by said electrode with a first transmission efficiency and ions having a mass to charge ratio in the range M3'-M3 are substantially injected or orthogonally accelerated into said drift region by said electrode with a second transmission efficiency lower than said first transmission efficiency, wherein M3' < M3.

[0015] Preferably, M3' falls within a range selected from the group consisting of: (i) 1-50; (ii) 50-100; (iii) 100-150; (iv) 150-200; (v) 200-250; (vi) 250-300; (vii) 300-350; (viii) 350-400; (ix) 400-450; (x) 450-500; (xi) 500-550; (xii) 550-600; (xiii) 600-650; (xiv) 650-700; (xv) 700-750; (xvi) 750-800; (xvii) 800-850; (xviii) 850-900; (xix) 900-950; (xx) 950-1000; (xxi) 1000-1500; (xxii) 1500-2000; (xxiii) 2000-2500; (xxiv) 2500-3000; and (xxv) > 3000.

[0016] The ion gate is switched from the second (OFF) mode to the first (ON) mode and then after a delay time ΔT_2 the pusher electrode is energised. ΔT_2 preferably falls within a range selected from the group consisting of: (i) 0.1-1 μ s; (ii) 1-5 μ s; (iii) 5-10 μ s; (iv) 10-15 μ s; (v) 15-20 μ s; (vi) 20-50 μ s; (vii) 50-100 μ s; (viii) 100-500 μ s; and (ix) 500-1000 μ s.

[0017] The high mass to charge ratio cut-off M3 preferably falls within a range selected from the group consisting of: (i) 1-50; (ii) 50-100; (iii) 100-150; (iv) 150-200; (v) 200-250; (vi) 250-300; (vii) 300-350; (viii) 350-400; (ix) 400-450; (x) 450-500; (xi) 500-550; (xii) 550-600; (xiii) 600-650; (xiv) 650-700; (xv) 700-750; (xvi) 750-800; (xvii) 800-850; (xviii) 850-900; (xix) 900-950; (xx) 950-1000; (xxi) 1000-1500; (xxii) 1500-2000; (xxiii) 2000-2500; (xxiv) 2500-3000; and (xxv) > 3000.

[0018] Preferably, immediately after said control means has caused said electrode to inject or orthogonally accelerate ions into said drift region at time $T_2 + \Delta T_2$ said control means switches said ion gate from said first mode to said second mode.

[0019] According to a third aspect of the present invention, there is provided a mass spectrometer comprising:

- an ion source;
- an orthogonal acceleration Time of Flight mass analyser comprising an electrode for orthogonally accelerating ions, an ion detector and a drift region therebetween;
- an ion gate upstream of the electrode; and
- control means for switching the ion gate between a

first mode and a second mode, the second mode having a lower ion transmission efficiency than the first mode, wherein in a mode of operation the control means:

- (i) switches the ion gate from the second mode to the first mode at a time T_3 ;
- (ii) switches the ion gate from the first mode to the second mode at a later time $T_3 + \delta T_3$; and
- (iii) causes the electrode to inject or orthogonally accelerate ions into the drift region at a yet later time $T_3 + \delta T_3 + \Delta T_3$;

wherein δT_3 and ΔT_3 are set such that ions having a mass to charge ratio \leq a value M1 are not substantially injected or orthogonally accelerated into the drift region by the electrode and such that ions having a mass to charge ratio \geq a value M3 are not substantially injected or orthogonally accelerated into the drift region by the electrode, wherein M1 < M3.

[0020] According to this embodiment only ions within a certain bandpass are orthogonally accelerated or otherwise injected into the drift region of the Time of Flight mass analyser. This enables low mass to charge ratio background ions and high mass to charge ratio background ions to be filtered out.

[0021] Preferably, ions having a mass to charge ratio M2 are substantially injected or orthogonally accelerated into said drift region by said electrode with a first transmission efficiency and other ions having a mass to charge ratio in the range M1-M3 are substantially injected or orthogonally accelerated into said drift region by said electrode with a second transmission efficiency lower than said first transmission efficiency, wherein M1 < M2 < M3. M2 preferably falls within a range selected from the group consisting of: (i) 1-50; (ii) 50-100; (iii) 100-150; (iv) 150-200; (v) 200-250; (vi) 250-300; (vii) 300-350; (viii) 350-400; (ix) 400-450; (x) 450-500; (xi) 500-550; (xii) 550-600; (xiii) 600-650; (xiv) 650-700; (xv) 700-750; (xvi) 750-800; (xvii) 800-850; (xviii) 850-900; (xix) 900-950; (xx) 950-1000; (xxi) 1000-1500; (xxii) 1500-2000; (xxiii) 2000-2500; (xxiv) 2500-3000; and (xxv) > 3000,

[0022] According to another form of the third embodiment, ions having a mass to charge ratio in a range M1'-M3' are substantially injected or orthogonally accelerated into said drift region by said electrode with a first transmission efficiency and ions having a mass to charge ratio in the range M1-M1' and M3'-M3 are substantially injected or orthogonally accelerated into said drift region by said electrode with a second transmission efficiency lower than said first transmission efficiency, wherein M1 < M1' < M3' < M3.

[0023] M1' preferably falls within a range selected from the group consisting of: (i) 1-50; (ii) 50-100; (iii) 100-150; (iv) 150-200; (v) 200-250; (vi) 250-300; (vii) 300-350; (viii) 350-400; (ix) 400-450; (x) 450-500; (xi) 500-550; (xii) 550-600; (xiii) 600-650; (xiv) 650-700; (xv) 700-750; (xvi)

750-800; (xvii) 800-850; (xviii) 850-900; (xix) 900-950; (xx) 950-1000; (xxi) 1000-1500; (xxii) 1500-2000; (xxiii) 2000-2500; (xxiv) 2500-3000; and (xxv) > 3000.

[0024] M3' preferably falls within a range selected from the group consisting of: (i) 1-50; (ii) 50-100; (iii) 100-150; (iv) 150-200; (v) 200-250; (vi) 250-300; (vii) 300-350; (viii) 350-400; (ix) 400-450; (x) 450-500; (xi) 500-550; (xii) 550-600; (xiii) 500-650; (xiv) 650-700; (xv) 700-750; (xvi) 750-800; (xvii) 800-850; (xviii) 850-900; (xix) 900-950; (xx) 950-1000; (xxi) 1000-1500; (xxii) 1500-2000; (xxiii) 2000-2500; (xxiv) 2500-3000; and (xxv) > 3000.

[0025] The length of time δT_3 that the ion gate remains in the first (ON) mode preferably falls within a range selected from the group consisting of: (i) 0.1-1 μ s; (ii) 1-5 μ s; (iii) 5-10 μ s; (iv) 10-15 μ s; (v) 15-20 μ s; (vi) 20-50 μ s; (vii) 50-100 μ s; (viii) 100-500 μ s; and (ix) 500-1000 μ s.

[0026] The delay time ΔT_3 preferably falls within a range selected from the group consisting of: (i) 0.1-1 μ s; (ii) 1-5 μ s; (iii) 5-10 μ s; (iv) 10-15 μ s; (v) 15-20 μ s; (vi) 20-50 μ s; (vii) 50-100 μ s; (viii) 100-500 μ s; and (ix) 500-1000 μ s.

[0027] M1 preferably falls within a range selected from the group consisting of: (i) 1-5; (ii) 5-10; (iii) 10-15; (iv) 15-20; (v) 20-25; (vi) 25-30; (vii) 30-35; (viii) 35-40; (ix) 40-45; (x) 45-50; (xi) 50-55; (xii) 55-60; (xiii) 60-65; (xiv) 65-70; (xv) 70-75; (xvi) 75-100; (xvii) 100-150; (xviii) 150-200; (xix) 200-250; (xx) 250-300; (xxi) 300-350; (xxii) 350-400; (xxiii) 400-450; (xxiv) 450-500; (xxv) 500-550; (xxvi) 550-600; (xxvii) 600-650; (xxviii) 650-700; (xxix) 700-750; (xxx) 750-800; (xxxi) 800-850; (xxxii) 850-900; (xxxiii) 900-950; (xxxiv) 950-1000; and (xxxv) > 1000.

[0028] M3 preferably falls within a range selected from the group consisting of: (i) 1-50; (ii) 50-100; (iii) 100-150; (iv) 150-200; (v) 200-250; (vi) 250-300; (vii) 300-350; (viii) 350-400; (ix) 400-450; (x) 450-500; (xi) 500-550; (xii) 550-600; (xiii) 600-650; (xiv) 650-700; (xv) 700-750; (xvi) 750-800; (xvii) 800-850; (xviii) 850-900; (xix) 900-950; (xx) 950-1000; (xxi) 1000-1500; (xxii) 1500-2000; (xxiii) 2000-2500; (xxiv) 2500-3000; and (xxv) > 3000.

[0029] According to a fourth aspect of the present invention, there is provided a mass spectrometer comprising:

an ion source;

an orthogonal acceleration Time of Flight mass analyser comprising an electrode for orthogonally accelerating ions, an ion detector and a drift region therebetween;

an ion gate upstream of said electrode; and

control means for switching said ion gate between a first mode and a second mode, said second mode having a lower ion transmission efficiency than said first mode, wherein in a mode of operation said control means:

(i) switches said ion gate from said first mode to said second mode at a time T_4 ;

(ii) switches said ion gate from said second mode to said first mode at a later time $T_4 + \delta T_4$; and

(iii) causes said electrode to inject or orthogonally accelerate ions into said drift region at a yet later time $T_4 + \delta T_4 + \Delta T_4$;

wherein δT_4 and ΔT_4 are set such that ions having a mass to charge ratio equal to a value M2 are not substantially injected or orthogonally accelerated into said drift region by said electrode.

[0030] Preferably, M2 falls within a range selected from the group consisting of: (i) 1-50; (ii) 50-100; (iii) 100-150; (iv) 150-200; (v) 200-250; (vi) 250-300; (vii) 300-350; (viii) 350-400; (ix) 400-450; (x) 450-500; (xi) 500-550; (xii) 550-600; (xiii) 600-650; (xiv) 650-700; (xv) 700-750; (xvi) 750-800; (xvii) 800-850; (xviii) 850-900; (xix) 900-950; (xx) 950-1000; (xxi) 1000-1500; (xxii) 1500-2000; (xxiii) 2000-2500; (xxiv) 2500-3000; and (xxv) > 3000.

[0031] Preferably, ions having a mass to charge ratio \leq a value M1 and ions having a mass to charge ratio \geq a value M3 are substantially injected or orthogonally accelerated into said drift region by said electrode with a first transmission efficiency, and wherein ions having a mass to charge in the range M1-M3 are substantially injected or orthogonally accelerated into said drift region by said electrode with a second transmission efficiency lower than said first transmission efficiency, wherein $M1 < M2 < M3$.

[0032] According to a fifth aspect of the present invention, there is provided a mass spectrometer comprising:

an ion source;

an orthogonal acceleration Time of Flight mass analyser comprising an electrode for orthogonally accelerating ions, an ion detector and a drift region therebetween;

an ion gate upstream of said electrode; and

control means for switching said ion gate between a first mode and a second mode, said second mode having a lower ion transmission efficiency than said first mode, wherein in a mode of operation said control means:

(i) switches said ion gate from said first mode to said second mode at a time T_4 ;

(ii) switches said ion gate from said second mode to said first mode at a later time $T_4 + \delta T_4$; and

(iii) causes said electrode to inject or orthogonally accelerate ions into said drift region at a yet later time $T_4 + \delta T_4 + \Delta T_4$;

wherein δT_4 and ΔT_4 are set such that ions having a mass to charge ratio in a range M1'-M3' are not substantially injected or orthogonally accelerated into said drift region by said electrode, wherein $M1' <$

M3'.

[0033] Preferably, M1' falls within a range selected from the group consisting of: (i) 1-50; (ii) 50-100; (iii) 100-150; (iv) 150-200; (v) 200-250; (vi) 250-300; (vii) 300-350; (viii) 350-400; (ix) 400-450; (x) 450-500; (xi) 500-550; (xii) 550-600; (xiii) 600-650; (xiv) 650-700; (xv) 700-750; (xvi) 750-800; (xvii) 800-850; (xviii) 850-900; (xix) 900-950; (xx) 950-1000; (xxi) 1000-1500; (xxii) 1500-2000; (xxiii) 2000-2500; (xxiv) 2500-3000; and (xxv) > 3000.

[0034] Preferably, M3' falls within a range selected from the group consisting of: (i) 1-50; (ii) 50-100; (iii) 100-150; (iv) 150-200; (v) 200-250; (vi) 250-300; (vii) 300-350; (viii) 350-400; (ix) 400-450; (x) 450-500; (xi) 500-550; (xii) 550-600; (xiii) 600-650; (xiv) 650-700; (xv) 700-750; (xvi) 750-800; (xvii) 800-850; (xviii) 850-900; (xix) 900-950; (xx) 950-1000; (xxi) 1000-1500; (xxii) 1500-2000; (xxiii) 2000-2500; (xxiv) 2500-3000; and (xxv) > 3000.

[0035] Preferably, ions having a mass to charge ratio \leq a value M1 and ions having a mass to charge ratio \geq a value M3 are substantially injected or orthogonally accelerated into said drift region by said electrode with a first transmission efficiency and ions having a mass to charge ratio in the range M1-M1' and ions having a mass to charge ratio in the range M3'-M3 are substantially injected or orthogonally accelerated into said drift region by said electrode with a second transmission efficiency lower than said first transmission efficiency, wherein $M1 < M1' < M3' < M3$.

[0036] Preferably, M1 falls within a range selected from the group consisting of: (i) 1-5; (ii) 5-10; (iii) 10-15; (iv) 15-20; (v) 20-25; (vi) 25-30; (vii) 30-35; (viii) 35-40; (ix) 40-45; (x) 45-50; (xi) 50-55; (xii) 55-60; (xiii) 60-65; (xiv) 65-70; (xv) 70-75; (xvi) 75-100; (xvii) 100-150; (xviii) 150-200; (xix) 200-250; (xx) 250-300; (xxi) 300-350; (xxii) 350-400; (xxiii) 400-450; (xxiv) 450-500; (xxv) 500-550; (xxvi) 550-600; (xxvii) 600-650; (xxviii) 650-700; (xxix) 700-750; (xxx) 750-800; (xxxi) 800-850; (xxxii) 850-900; (xxxiii) 900-950; (xxxiv) 950-1000; and (xxxv) > 1000.

[0037] Preferably, M3 falls within a range selected from the group consisting of (i) 1-50; (ii) 50-100; (iii) 100-150; (iv) 150-200; (v) 200-250; (vi) 250-300; (vii) 300-350; (viii) 350-400; (ix) 400-450; (x) 450-500; (xi) 500-550; (xii) 550-600; (xiii) 600-650; (xiv) 650-700; (xv) 700-750; (xvi) 750-800; (xvii) 800-850; (xviii) 850-900; (xix) 900-950; (xx) 950-1000; (xxi) 1000-1500; (xxii) 1500-2000; (xxiii) 2000-2500; (xxiv) 2500-3000; and (xxv) > 3000.

[0038] Preferably, the period of time δT_4 that the ion gate is switched to the second (OFF) mode falls within a range selected from the group consisting of: (i) 0.1-1 μ s; (ii) 1-5 μ s; (iii) 5-10 μ s; (iv) 10-15 μ s; (v) 15-20 μ s; (vi) 20-50 μ s; (vii) 50-100 μ s; (viii) 100-500 μ s; and (ix) 500-1000 μ s.

[0039] Preferably, the delay time ΔT_4 falls within a range selected from the group consisting of: (i) 0.1-1 μ s; (ii) 1-5 μ s; (iii) 5-10 μ s; (iv) 10-15 μ s; (v) 15-20 μ s; (vi)

20-50 μ s; (vii) 50-100 μ s; (viii) 100-500 μ s; and (ix) 500-1000 μ s.

[0040] Common to all embodiments the electrode preferably comprises a pusher and/or puller electrode. The ion gate may comprise one or more electrodes for altering, deflecting, reflecting, defocusing, attenuating or blocking a beam of ions. Preferably, in said second mode said ion transmission efficiency is substantially 0% but according to a less preferred embodiment in said second mode said ion transmission efficiency is # x% of the ion transmission efficiency in said first mode, wherein x falls within a range selected from the group consisting of: (i) 0.001-0.01; (ii) 0,01-0.1; (iii) 0.1-1; (iv) 1-10; and (v) 10-90.

[0041] Preferably, the electrode is repeatedly energised with a frequency selected from the group consisting of: (i) 100-500 Hz; (ii) 0.5-1 kHz; (iii) 1-5 kHz; (iv) 5-10 kHz; (v) 10-20 kHz; (vi) 20-30 kHz; (vii) 30-40 kHz; (viii) 40-50 kHz; (ix) 50-60 kHz; (x) 60-70 kHz; (xi) 70-80 kHz; (xii) 80-90 kHz; (xiii) 90-100 kHz; (xiv) 100-500 kHz; (xv) 0.5-1 MHz; and (xvi) > 1 MHz.

[0042] The ion source preferably comprises a continuous ion source. For example, the ion source may be selected from the group consisting of: (i) an Electron Impact ("EI") ion source; (ii) a Chemical Ionisation ("CI") ion source; (iii) a Field Ionisation ("FI") ion source; (iv) an Electrospray ion source; (v) an Atmospheric Pressure Chemical Ionisation ("APCI") ion source; (vi) an Inductively Coupled Plasma ("ICP") ion source; (vii) an Atmospheric Pressure Photo Ionisation ("APPI") ion source; (viii) a Fast Atom Bombardment ("FAB") ion source; and (ix) a Liquid Secondary Ions Mass Spectrometry ("LSIMS") ion source.

[0043] According to a less preferred embodiment the ion source is a pseudo-continuous ion source. For example, the ion source may be selected from the group consisting of: (i) a Matrix Assisted Laser Desorption Ionisation ("MALDI") ion source; and (ii) a Laser Desorption Ionisation ("LDI") ion source. Preferably, an RF ion guide comprising a collision gas for dispersing a packet of ions emitted by said ion source is provided.

[0044] The ion source may be coupled to a liquid or gas chromatography source.

[0045] According to a sixth aspect of the present invention, there is provided a method of mass spectrometry, comprising :

switching an ion gate from a first mode to a second mode at a time T_1 , said second mode having a lower ion transmission efficiency than said first mode; and injecting or orthogonally accelerating ions into a drift region of an orthogonal acceleration Time of Flight mass analyser at a later time $T_1 + \Delta T_1$; wherein ΔT_1 is set such that ions having a mass to charge ratio \leq a value M1 are not substantially injected or orthogonally accelerated into said drift region.

[0046] According to a seventh aspect of the present invention, there is provided a method of mass spectrometry, comprising:

switching an ion gate from a second mode to a first mode at a time T_2 , said second mode having a lower ion transmission efficiency than said first mode; and injecting or orthogonally accelerating ions into a drift region of an orthogonal acceleration Time of Flight mass analyser at a later time $T_2 + \Delta T_2$; wherein ΔT_2 is set such that ions having a mass to charge ratio \geq a value $M3$ are not substantially injected or orthogonally accelerated into said drift region.

[0047] According to an eighth aspect of the present invention, there is provided a method of mass spectrometry, comprising:

switching an ion gate from a second mode to a first mode at a time T_3 , said second mode having a lower ion transmission efficiency than said first mode; switching said ion gate from said first mode to said second mode at a later time $T_3 + \delta T_3$; and injecting or orthogonally accelerating ions into a drift region of an orthogonal acceleration Time of Flight mass analyser at a yet later time $T_3 + \delta T_3 + \Delta T_3$; wherein δT_3 and ΔT_3 are set such that ions having a mass to charge ratio \leq a value $M1$ are not substantially injected or orthogonally accelerated into said drift region and such that ions having a mass to charge ratio \geq a value $M3$ are not substantially injected or orthogonally accelerated into said drift region, wherein $M1 < M3$.

[0048] According to a ninth aspect of the present invention, there is provided a method of mass spectrometry, comprising:

switching an ion gate from a first mode to a second mode at a time T_4 , said second mode having a lower ion transmission efficiency than said first mode; switching said ion gate from said second mode to said first mode at a later time $T_4 + \delta T_4$; and injecting or orthogonally accelerating ions into a drift region of an orthogonal acceleration Time of Flight mass analyser at a yet later time $T_4 + \delta T_4 + \Delta T_4$; wherein δT_4 and ΔT_4 are set such that ions having a mass to charge ratio equal to a value $M2$ are not substantially injected or orthogonally accelerated into said drift region.

[0049] According to a tenth aspect of the present invention, there is provided a method of mass spectrometry, comprising:

switching an ion gate from a first mode to a second mode at a time T_4 , said second mode having a lower

ion transmission efficiency than said first mode; switching said ion gate from said second mode to said first mode at a later time $T_4 + \delta T_4$; and injecting or orthogonally accelerating ions into a drift region of an orthogonal acceleration Time of Flight mass analyser at a yet later time $T_4 + \delta T_4 + \Delta T_4$; wherein δT_4 and ΔT_4 are set such that ions having a mass to charge ratio in a range $M1' - M3'$ are not substantially injected or orthogonally accelerated into said drift region, wherein $M1' < M3'$.

[0050] In the present application where reference is made to ions having a mass to charge ratio this is intended to mean ions having a mass to charge ratio measured in units of daltons.

[0051] Various embodiments of the present invention will now be described, by way of example only, and with reference to the accompanying drawings in which:

Fig. 1 shows a preferred mass spectrometer; Fig. 2 illustrates a first embodiment wherein relatively low mass to charge ratio ions are prevented from reaching the ion detector; Fig. 3 illustrates ions of different mass to charge ratios adjacent the pusher electrode according to the first embodiment; Fig. 4 shows the relative transmission of ions as a function of mass to charge ratio according to the first embodiment; Fig. 5 illustrates a second embodiment wherein relatively high mass to charge ratio ions are prevented from reaching the ion detector; Fig. 6 shows the relative transmission of ions as a function of mass to charge ratio according to the second embodiment; Fig. 7 illustrates a third embodiment wherein both relatively low mass to charge ratio ions and relatively high mass to charge ratio ions are prevented from reaching the ion detector; Fig. 8 shows the relative transmission of ions as a function of mass to charge ratio according to the third embodiment; Fig. 9 shows the relative transmission of ions as a function of mass to charge ratio according to a variation of the third embodiment; Fig. 10 illustrates a fourth embodiment wherein only ions having a relatively narrow range of mass to charge ratios are prevented from reaching the ion detector; Fig. 11 shows the relative transmission of ions as a function of mass to charge ratio according to the fourth embodiment; Fig. 12 shows the relative transmission of ions as a function of mass to charge ratio according to a variation of the fourth embodiment; Fig. 13(a) shows a timing diagram for the first embodiment, Fig. 13(b) shows a timing diagram for the second embodiment, Fig. 13(c) shows a timing dia-

gram for the third embodiment, and Fig. 13(d) shows a timing diagram for the fourth embodiment; Fig. 14(a) shows a mass spectrum obtained according to the first embodiment and Fig. 14(b) shows a corresponding mass spectrum obtained conventionally;

Figs. 15(a) shows the same mass spectrum shown in Fig. 14(a) but displayed over the reduced mass to charge ratio range 15-200 daltons, Fig. 15(b) shows the same mass spectrum shown in Fig. 14(b) but displayed over the reduced mass to charge ratio range 15-200 daltons, and Fig. 15(c) shows the theoretically calculated relative transmission as a function of mass to charge ratio according to the first embodiment; and

Fig. 16(a) shows the same mass spectrum as shown in Fig. 14(a) and Fig. 15(a) but displayed over the yet further reduced mass to charge ratio range 15-66 daltons with the intensity magnified by a factor of 280, and Fig. 16(b) shows the same mass spectrum as shown in Fig. 14(b) and Fig. 15(b) but displayed over the yet further reduced mass to charge ratio range 15-66 daltons.

[0052] Various embodiments of the present invention will now be described in more detail with reference to Fig. 1. Ions emitted by an ion source 1 pass to an electrostatic device 2 arranged upstream of an acceleration chamber 3 of an orthogonal acceleration Time of Flight mass analyser. The electrostatic device 2 may comprise a single deflection electrode or more preferably a pair of electrodes arranged preferably in parallel and further preferably connected to a voltage supply. The electrostatic device 2 is preferably used to alter, deflect, reflect, defocus, attenuate or block an ion beam incident upon the device 2.

[0053] In one embodiment the electrostatic device 2 does not have any attenuating voltage applied to the device 2 when the device 2 is ON. When the device 2 is OFF a voltage is applied to device 2 in order to deflect ions. The electrostatic device 2 acts as an ion gate 2 allowing ions to be transmitted in a first (ON) mode. In a second (OFF) mode the ion gate 2 substantially reduces, preferably prevents, ions from being onwardly transmitted to the Time of Flight mass analyser.

[0054] The ion gate 2 is preferably positioned in a field free region of ion transfer optics between the ion source 1 and the orthogonal acceleration pusher electrode 4 which forms part of an orthogonal acceleration Time of Flight mass analyser. The orthogonal acceleration Time of Flight mass analyser comprises a pusher electrode 4, a drift region 5, an optional reflectron 6 and an ion detector 7. The voltage supply to the ion gate 2 is preferably capable of being switched ON/OFF in approximately 100 ns.

[0055] According to the first embodiment the ion gate 2 is set to be ON for the majority of a Cycle T_c so as to transmit ions. In order to discriminate against ions with

low mass to charge ratios the ion gate 2 is switched to be OFF for preferably a relatively short period of time ΔT_1 . A short time ΔT_1 after the ion gate 2 has been switched OFF a pusher voltage is applied to the orthogonal acceleration pusher electrode 4. As soon as the pusher voltage is applied the ion gate 2 is preferably switched back to ON. The ion gate 2 preferably remains ON until the beginning of the next cycle T_c when it is again switched OFF. This cycle of switching the ion gate 2 ON/OFF may be repeated many times during one experimental run.

[0056] Fig. 2 shows a schematic representation of a mode of operation of the mass spectrometer according to the first embodiment. It is assumed that a continuous ion beam is arriving at the ion gate 2. The ions transmitted by the ion gate 2 continue to the region adjacent the pusher electrode 4. The distance from the ion gate 2 to the pusher electrode 4 may be defined as L_1 , the length of the pusher electrode may be defined as L_2 and the distance from the pusher electrode 4 to the ion detector 7 may be defined as L_3 . For ease of illustration only, the ion detector 7 is shown as being the same length L_2 as the pusher electrode 4 although this is not relevant to the principle of operation.

[0057] Low mass to charge ratio ions having a mass to charge ratio $\leq M_1$ have passed the pusher electrode 4 before it is energised whereas ions having a mass to charge ratio $> M_1$ are disposed opposite the pusher electrode 4 and hence are orthogonally accelerated by the pusher electrode 4 into the drift region 5 of the Time of Flight mass analyser. Ions having a mass to charge ratio $\geq M_1'$ are orthogonally accelerated with a relative transmission of 100% and ions having a mass to charge ratio in the range M_1-M_1' are orthogonally accelerated with a relative transmission between 0% and 100%. The relative transmission is shown and explained in more detail in relation to Fig. 4.

[0058] In an orthogonal acceleration Time of Flight mass spectrometer the acceleration of ions into the drift region 5 of the Time of Flight mass analyser is orthogonal to the axial direction of the ion beam and hence the axial component of velocity of the ions remains unchanged. Therefore, the time taken for ions to pass through the drift region 5 of the Time of Flight mass analyser to the ion detector 7 is the same as the time it would have taken for the ions to have travelled the axial distance L_2+L_3 from the end of the pusher electrode 4 closest to the ion gate 2 to the ion detector 7 had they not been accelerated into the drift region 5.

[0059] If the maximum mass to charge ratio of ions arranged to be analysed by the mass analyser is M_{max} then the cycle time T_c between consecutive pulses of ions into the drift region 5 is the time required for ions of mass to charge ratio M_{max} to travel the distance L_2+L_3 from the pusher electrode 4 to the ion detector 7. In addition to showing the positions of ions having mass to charge ratios equal to M_1 and M_1' at the time the pusher electrode 4 is about to be energised, Fig. 2 also shows

the position of ions having a mass to charge ratio M_{\max} at the time the voltage is about to be applied to the pusher electrode 4. The ions are orthogonally accelerated in the drift region 5 after a delay time ΔT_1 since the ion gate 2 was switched from ON to OFF.

[0060] Ions of mass to charge ratio equal to $M1$ have travelled the distance $L1+L2$ since the ion gate 2 was switched OFF and therefore ions having a mass to charge ratio $\leq M1$ will not be transmitted into the drift region 5 of the Time of Flight mass analyser. Ions having a mass to charge ratio $M1'$ have travelled the distance $L1$ since the ion gate 2 was switched OFF and these ions will be transmitted into the Time of Flight mass analyser with a relative transmission of 100%.

[0061] If the ions have an energy of zeV electron volts, distances are in metres, and ΔT_1 is in μs , then the value of $M1$ in daltons is given by:

$$M1 = \frac{V \cdot \Delta T_1^2}{5184 (L1 + L2)^2}$$

and the value of $M1'$ in daltons is given by:

$$M1' = \frac{V \cdot \Delta T_1^2}{5184 L1^2}$$

hence:

$$M1' = M1 \cdot \left(1 + \frac{L2}{L1}\right)^2$$

[0062] The relative transmission Tr of ions into the drift region 5 is equal to the relative proportion of the space opposite the pusher electrode 4 occupied by ions of mass to charge ratio M . Accordingly:

$$Tr = \frac{L1 + L2 - L}{L2}$$

or

$$Tr = 1 - \frac{1}{L2} \cdot (L - L1)$$

where L is the distance travelled by ions with mass to charge M :

$$L = \frac{\Delta T_1}{72} \sqrt{\frac{V}{M}}$$

hence:

$$Tr = 1 - \frac{1}{L2} \left(\frac{\Delta T_1}{72} \sqrt{\frac{V}{M}} - L1 \right)$$

[0063] Fig. 3 is similar to Fig. 2 and shows the disposition of ions having various different mass to charge ratios at the time $T_1 + \Delta T_1$ when the pusher electrode 4 is energised. Ions having a mass to charge ratio $\leq M1$ are not orthogonally accelerated, ions having a mass to charge ratio in the range $M1-M1'$ are orthogonally accelerated with a relative transmission $< 100\%$ and ions having a mass to charge ratio $\geq M1'$ are orthogonally accelerated with a relative transmission of 100%.

[0064] Fig. 4 shows the relative transmission as a function of mass to charge ratio according to the first embodiment for an ion energy of 90 eV, delay time ΔT_1 of 6 μs and wherein $L1$ was 110 mm, $L2$ was 30 mm, $L3$ was 114 mm. M_{\max} was set to 1500 daltons. For these values $M1$ equals 32 daltons and $M1'$ equals 52 daltons. Accordingly, ions having a mass to charge ratio ≤ 32 daltons are not orthogonally accelerated whereas ions having a mass to charge ratio ≥ 52 daltons are orthogonally accelerated with 100% relative transmission. Ions having a mass to charge ratio between 32 and 52 daltons are orthogonally accelerated with a relative transmission between 0% and 100%.

[0065] Any ions present with a mass to charge ratio value equal to M_{\max} will have a 100% relative transmission provided that the distance $L1$ is not greater than the distance $L3$. Fig. 2 shows that ions with a mass to charge ratio equal to M_{\max} from a first cycle A are separated from ions having the same mass to charge from a second subsequent cycle B by a small gap. This gap is due to the effect of the ion gate 2 from the previous cycle A and corresponds with the period of time when no ions are transmitted by the ion gate 2. Fig. 2 shows where this gap will exist at the time the pusher voltage is about to be applied to the pusher electrode 4. As can be seen, this gap starts a distance $L1$ before the ion detector 7 and accordingly if $L1$ is greater than $L3$ then the gap could appear in the region adjacent the pusher electrode 4. This would lead to a small reduction in transmission depending on the relative values of the parameters $L1$, $L2$, $L3$, ΔT_1 and T_c . Any potential loss in transmission can be avoided if $L1$ is not greater than $L3$ and hence preferably the distance $L1$ is arranged to be less than $L3$.

[0066] According to the first embodiment ions having a relatively low mass to charge ratio are substantially

prevented from being orthogonally accelerated in the drift region 5 of the Time of Flight mass analyser. This is particularly advantageous in a number of different situations. For example, with an Electron Impact ("EI") ion source He^+ ions ($m/z = 4$) from the carrier gas for the Gas Chromatograph or N_2^+ ions ($m/z = 28$) from air may be particularly intense and can advantageously be excluded according to this embodiment.

[0067] With a Chemical Ionisation ("CI") ion source using methane as the reagent gas C_2H_5^+ ions ($m/z = 29$), CH_5^+ ions ($m/z = 17$) and C_3H_5^+ ions ($m/z = 41$) may be particularly intense and can advantageously be excluded according to this embodiment. Similarly, when using ammonia as the reagent gas NH_4^+ ions ($m/z = 18$) may be particularly intense and can advantageously be excluded according to this embodiment.

[0068] The preferred embodiment is also suitable for use with other types of ion source. For example, with an ICP ion source Ar^+ ions ($m/z = 40$) may be particularly intense and can be advantageously excluded according to this embodiment.

[0069] With a Matrix Assisted Laser Desorption Ionisation (MALDI) ion source there are numerous different background ions which may be generated due to the various matrices used. For examples, ions having a mass to charge ratio of 379 and 568 which correspond with the dimer and trimer of the matrix alpha cyano-4-hydroxycinnamic acid can be particularly intense. Similarly, ions having a mass to charge ratio of 139 are observed when using 2,5, dihydroxybenzoic acid (DHB) as the MALDI matrix. These ions can be advantageously excluded according to either the first embodiment or according to one of the further embodiments described in more detail below.

[0070] With a Liquid Secondary Ion Mass Spectrometry (ALSIMS) or Fast Atom Bombardment (AFAB) ion source using glycerol as the matrix $\text{C}_3\text{H}_9\text{O}_3^+$ ions ($m/z = 93$) and $\text{C}_6\text{H}_{17}\text{O}_6^+$ ions ($m/z = 185$) can be particularly intense and may be advantageously excluded according to the first embodiment or one of the further embodiments described in more detail below.

[0071] A second embodiment wherein relatively high mass to charge ratio ions may be excluded will now be described in relation to Fig. 5. Some ion sources have a continuum of background ions extending to quite high mass to charge ratios and the background ions may in some circumstances have higher mass to charge ratios than those of the analyte ions being analysed. Such high mass to charge ratio ions may be of sufficient intensity to cause a problem with an orthogonal acceleration Time of Flight mass spectrometer. It is normally necessary with an orthogonal acceleration Time of Flight mass analyser to wait until the ions having the highest mass to charge ratios arrive at the ion detector 7 before the pusher electrode 4 is energised again to orthogonally accelerate the next bunch of ions into the drift region 5. Otherwise, high mass to charge ratio ions from a first bunch of ions may arrive at the ion detector 7 together with low mass to

charge ratio ions from a subsequent second bunch of ions. These high mass to charge ratio ions would therefore contribute noise and would present artefact peaks within the resulting mass spectrum.

[0072] Also, where background ions extend to much higher mass to charge ratios than the mass to charge ratio of the analyte ions this may make it necessary to wait for relatively long periods of time between pusher electrode pulses thereby reducing the duty cycle and hence lowering the sensitivity of the mass spectrometer. Accordingly, providing a high mass cut-off mode may be particularly advantageous in that this will eliminate noise and possible artefact peaks whilst maintaining the highest possible duty cycle and sensitivity.

[0073] According to the second embodiment the ion gate 2 is set to be OFF for the majority of a cycle so as to prevent ions being transmitted. In order to discriminate against ions with relatively high mass to charge ratios the ion gate 2 is switched to be ON for preferably a relatively short period of time ΔT_2 . A short time ΔT_2 after the ion gate 2 has been switched ON a pusher voltage is applied to the orthogonal acceleration pusher electrode 4. As soon as the pusher voltage is applied to the pusher electrode 4 the ion gate 2 is preferably switched OFF. The ion gate 2 preferably remains OFF until the beginning of the next cycle T_c when it is again switched ON. This cycle of switching the ion gate 2 ON/OFF may be repeated many times during one experimental run.

[0074] Ions of mass to charge ratio $M3'$ are those ions that have just travelled the axial distance $L1+L2$ since the ion gate 2 was switched ON. Accordingly, ions having a mass to charge ratio $\leq M3'$ are orthogonally accelerated with a relative transmission of 100%.

[0075] If the ions have an energy of zeV electron volts, distances are in metres, and ΔT_2 is in μs , then the value of $M3'$ in daltons is given by:

$$M3' = \frac{V \Delta T_2^2}{5184 (L1 + L2)^2}$$

and the value of $M3$ in daltons is given by:

$$M3 = \frac{V \Delta T_2^2}{5184 L1^2}$$

hence :

$$M3 = M3' \left(1 + \frac{L2}{L1} \right)^2$$

[0076] The relative transmission Tr of ions into the drift

region 5 is equal to the relative proportion of the space opposite the pusher electrode 4 occupied by ions of mass to charge ratio M, therefore:

$$Tr = \frac{L - L1}{L2}$$

or

$$Tr = \frac{1}{L2} \cdot (L - L1)$$

where L is the distance travelled by ions with mass to charge M. Accordingly :

$$L = \frac{\Delta T_2}{72} \cdot \sqrt{\frac{V}{M}}$$

hence:

$$Tr = \frac{1}{L2} \left(\frac{\Delta T_2}{72} \sqrt{\frac{V}{M}} - L1 \right)$$

[0077] Fig. 6 shows the relative transmission as a function of mass to charge ratio according to the second embodiment for an ion energy of 40 eV, delay time ΔT_2 of 15 μ s and wherein L1 was 60 mm, L2 was 30 mm and L3 was 60 mm. M_{max} was set to 800 daltons. For these values $M3'$ equals 214 daltons and M3 equals 480 daltons. Accordingly, ions having a mass to charge ratio \leq 214 daltons are orthogonally accelerated with a relative transmission of 100% whereas ions having a mass to charge ratio \geq 480 daltons are not orthogonally accelerated. Ions having a mass to charge ratio between 214 and 480 daltons are orthogonally accelerated with a relative transmission between 0% and 100%.

[0078] The ability to be able to filter out relatively high mass to charge ratio ions is particularly advantageous with Gas Chromatograph ("GC") Mass Spectrometry where it is normally required to only analyse relatively low mass to charge ratio analyte ions, for example ions in the mass range 100-200 daltons. GC mass spectrometers can suffer from "bleed" peaks from the GC column as high as 600-1000 daltons and it can therefore be necessary to have to wait until these ions arrive before firing the next pulse. Such an approach is obviously inefficient. This wait can be eliminated by the use of the high mass cut-off method according to the second embodiment.

[0079] Fast Atom Bombardment ("FAB") and Liquid

Secondary Ions Mass Spectrometry ("LSIMS") ion sources are notorious for giving a high level of background ions having very high mass to charge ratios (e.g. > 3000 daltons). The second embodiment is therefore particularly suitable for use with FAB and LSIMS ion sources.

[0080] A third embodiment relating to bandpass transmission mode of operation wherein both relatively high mass to charge ratio ions and relatively low mass to charge ratio ions are removed will now be described in relation to Fig. 7.

[0081] According to the third embodiment the ion gate 2 is set to be OFF for the majority of a cycle T_c so as to prevent ions being transmitted. In order to orthogonally accelerate only ions within a bandpass range of mass to charge ratios the ion gate 2 is switched to be ON for preferably a relatively short period of time δT_3 . A short time ΔT_3 after the ion gate 2 has been switched back from ON to OFF a pusher voltage is applied to the orthogonal acceleration pusher electrode 4. As soon as the pusher voltage is applied the ion gate 2 preferably remains switched OFF. The ion gate 2 preferably remains OFF until the beginning of the next cycle T_c when it is again switched ON for a relatively short period of time. This cycle of switching the ion gate 2 ON/OFF may be repeated many times during one experimental run.

[0082] Ions of mass to charge ratio M1 are those ions that have just travelled the axial distance L1+L2 since the ion gate 2 was switched from ON to OFF. Accordingly, ions having a mass to charge ratio \leq M1 are not orthogonally accelerated. Similarly, ions having a mass to charge ratio \geq M3 are not orthogonally accelerated. Ions having a mass to charge ratio M2 are orthogonally accelerated with a relative transmission of 100% and other ions having a mass to charge ratio within the range M1-M3 are orthogonally accelerated with a relative transmission between 0% and 100%.

[0083] Fig. 8 shows the relative transmission as a function of mass to charge ratio according to the third embodiment for an ion energy of 40 eV, δT_3 of 3.25 μ s, delay time ΔT_3 of 6.5 μ s and wherein L1 was 60 mm, L2 was 30 mm and L3 was 60 mm. M_{max} was set to 800 daltons. For these values M1 equals 40 daltons, M2 equals 90 daltons and M3 equals 204 daltons. Accordingly, ions having a mass to charge ratio \leq 40 daltons are not orthogonally accelerated and similarly ions having a mass to charge ratio \geq 204 daltons are not orthogonally accelerated. Ions having a mass to charge ratio between 90 and 204 daltons are orthogonally accelerated with a relative transmission between 0% and 100%.

[0084] A variation of the third embodiment is contemplated wherein the range of ions orthogonally accelerated with 100% relative transmission is increased. This can be achieved by increasing the time δT_3 that the ion gate 2 is ON. This is illustrated further with reference to Fig. 9 which shows the relative transmission as a function of mass to charge ratio according to the variation of the third embodiment for an ion energy of 40 eV, δT_3 of 8.5 μ s, delay time ΔT_3 of 6.5 μ s and wherein L1 was 60 mm, L2

was 30 mm and L3 was 60 mm. M_{\max} was set to 800 daltons. For these values M1 equals 40 daltons, M1' equals 90 daltons, M3' equals 214 daltons and M3 equals 480 daltons. Accordingly, ions having a mass to charge ratio ≤ 40 daltons are not orthogonally accelerated and similarly ions having a mass to charge ratio ≥ 480 daltons are not orthogonally accelerated. Ions having a mass to charge ratio between 90 and 214 daltons are orthogonally accelerated with a relative transmission of 100% and ions having a mass to charge ratio between 40 and 90 daltons and between 214 and 480 daltons are orthogonally accelerated with a relative transmission between 0% and 100%.

[0085] A mass spectrometer according to the third embodiment may be used to filter out both relatively low mass to charge ratio ions and relatively high mass to charge ratio ions as discussed above in relation to the first and second embodiments.

[0086] A fourth embodiment relating to bandpass filter mode of operation wherein only ions falling within a specific relatively narrow range of mass to charge ratios are removed will now be described in relation to Fig. 10.

[0087] According to the fourth embodiment the ion gate 2 is set to be ON for the majority of a cycle T_c so as to transmit ions. In order to orthogonally accelerate ions but not those falling within a specific range of mass to charge ratios the ion gate 2 is switched to be OFF for preferably a relatively short period of time δT_4 . A short time ΔT_4 after the ion gate 2 has been switched back from OFF to ON a pusher voltage is applied to the orthogonal acceleration pusher electrode 4. As soon as the pusher voltage is applied the ion gate 2 preferably remains switched ON. The ion gate 2 preferably remains ON until the beginning of the next cycle T_c when it is again switched OFF. This cycle of switching the ion gate 2 ON/OFF may be repeated many times during one experimental run.

[0088] Ions of mass to charge ratio M1 are those ions that have just travelled the axial distance L1+L2 since the ion gate 2 was switched from OFF to ON. Accordingly, ions having a mass to charge ratio $\leq M1$ are orthogonally accelerated with a relative transmission of 100%. Ions having a mass to charge ratio $\geq M3$ are present from the previous cycle and are also orthogonally accelerated with a relative transmission of 100%. Ions having a mass to charge ratio M2 are not orthogonally accelerated and other ions having a mass to charge ratio within the range M1-M3 are orthogonally accelerated with a relative transmission between 0% and 100%.

[0089] Fig. 11 shows the relative transmission as a function of mass to charge ratio according to the fourth embodiment for an ion energy of 40 eV, δT_3 of 3.25 μs , delay time ΔT_3 of 6.5 μs and wherein L1 was 60 mm, L2 was 30 mm and L3 was 60 mm. M_{\max} was set to 800 daltons. For these values M1 equals 40 daltons, M2 equals 90 daltons and M3 equals 204 daltons. Accordingly, ions having a mass to charge ratio ≤ 40 daltons are orthogonally accelerated with 100% relative transmission and similarly ions having a mass to charge ratio \geq

204 daltons are orthogonally accelerated with 100% relative transmission. Ions having a mass to charge ratio between 90 and 204 daltons are orthogonally accelerated with a relative transmission between 0% and 100%, and ions having a mass to charge ratio of 90 daltons are not orthogonally accelerated.

[0090] A variation of the fourth embodiment is contemplated wherein the range of ions not orthogonally accelerated is increased. This can be achieved by increasing the time that the ion gate 2 is closed. This is illustrated further with reference to Fig. 12 which shows the relative transmission as a function of mass to charge ratio according to the variation of the fourth embodiment for an ion energy of 40 eV, δT_3 of 8.5 μs , delay time ΔT_3 of 6.5 μs and wherein L1 was 60 mm, L2 was 30 mm and L3 was 60 mm. M_{\max} was set to 800 daltons. For these values M1 equals 40 daltons, M1' equals 90 daltons, M3' equals 214 daltons and M3 equals 480 daltons. Accordingly, ions having a mass to charge ratio ≤ 40 daltons are orthogonally accelerated with 100% relative transmission and similarly ions having a mass to charge ratio ≥ 480 daltons are orthogonally accelerated with 100% relative transmission. Ions having a mass to charge ratio between 90 and 214 daltons are not orthogonally accelerated and ions having a mass to charge ratio between 40 and 90 daltons and between 214 and 480 daltons are orthogonally accelerated with a relative transmission between 0% and 100%.

[0091] The mass spectrometer according to the fourth embodiment may be used, for example, with an ICP ion source. An ICP ion source is used for analysis of elements but normally gives rise to a very intense peak at mass to charge ratio 40 due to Ar^+ ions from the argon plasma support gas. Therefore, since it may be desired to analyse both relatively low mass atomic ions such as elements from lithium at mass to charge ratio 6 to sulphur at mass to charge ratio 32 and relatively high mass atomic ions such as elements from scandium at mass to charge ratio 45 to uranium and beyond on an orthogonal acceleration Time of Flight mass spectrometer then it would be highly beneficial to use the bandpass filtering mode of operation according to the fourth embodiment wherein the intense argon ions at mass to charge ratio 40 can be effectively filtered out.

[0092] Fig. 13(a) shows a timing diagram for the first embodiment. The ion gate 2 is switched from ON to OFF at time T_1 and then after a delay time ΔT_1 the pusher electrode is energised (shown by an arrow) and immediately thereafter the ion gate 2 is switched back from OFF to ON, and remains ON for the rest of the cycle T_c .

[0093] Fig. 13(b) shows a timing diagram for the second embodiment. The ion gate 2 is switched from OFF to ON at time T_2 and then after a delay time ΔT_2 the pusher electrode is energised (shown by an arrow) and immediately thereafter the ion gate 2 is switched back from ON to OFF, and remains OFF for the rest of the cycle T_c .

[0094] Fig. 13(c) shows a timing diagram for the third

embodiment. The ion gate 2 is switched from OFF to ON at time T_3 and remains ON for a time δT_3 . At time $T_3 + \delta T_3$ the ion gate 2 is switched back from ON to OFF and then after a delay time ΔT_3 the pusher electrode is energised (shown by an arrow). The ion gate 2 remains OFF for the rest of the cycle T_c .

[0095] Fig. 13(d) shows a timing diagram for the fourth embodiment. The ion gate 2 is switched from ON to OFF at time T_4 and remains OFF for a time δT_4 . At time $T_4 + \delta T_4$ the ion gate 2 is switched back from OFF to ON and then after a delay time ΔT_4 the pusher electrode is energised (shown by an arrow). The ion gate 2 remains ON for the rest of the cycle T_c .

[0096] Fig. 14 shows data obtained using an Electron Impact ("EI") ion source and the calibration compound Heptacosane (PFTBA) which was continuously introduced into an orthogonal acceleration Time of Flight mass spectrometer via a septum inlet. Fig. 14(a) shows a mass spectrum obtained when using low mass cut-off according to the first embodiment when L1 was 104 mm, L2 was 30 mm and L3 was 71 mm. The ion energy was 43 eV and the delay time ΔT_1 was 9.0 μ s. An ion gate voltage of +9V was used. From these values M1 was calculated to be 37 daltons and M1' was calculated to be 62 daltons. Fig. 14(b) shows a mass spectrum of Heptacosane (PFTBA) obtained conventionally.

[0097] Fig. 15(a) shows the same mass spectrum shown in Fig. 14(a) but displayed over the reduced mass to charge range 15-200 daltons. Fig. 15(b) shows the same mass spectrum shown in Fig. 14(b) but displayed over the reduced mass to charge range 15-200 daltons. Fig. 15(c) shows the theoretically calculated relative transmission as a function of mass to charge ratio according to the first embodiment. M1 and M1' are indicated by dotted lines on each diagram. It will be observed that there is no loss of intensity for ions of mass to charge ratio $> M1'$ (62 daltons) in the mass spectrum obtained according to the preferred embodiment compared with the mass spectrum obtained according to a conventional arrangement.

[0098] Fig. 16(a) shows the same mass spectrum as shown in Fig. 14(a) and Fig. 15(a) but displayed over the yet further reduced mass to charge range 15-66 daltons with the intensity magnified by a factor of 280. Fig. 16(b) shows the same mass spectrum as shown in Fig. 14(b) and Fig. 15(b) but displayed over the yet further reduced mass to charge range 15-66 daltons. These Figures illustrate the complete absence of ions having a mass to charge ratio $< M1$.

[0099] Although the present invention has been described with reference to preferred embodiments, it will be understood by those skilled in the art that various changes in form and detail may be made without departing from the scope of the invention as set forth in the accompanying claims.

Claims

1. A mass spectrometer comprising:

an ion source;
 an orthogonal acceleration Time of Flight mass analyser comprising an electrode for orthogonally accelerating ions, an ion detector and a drift region therebetween;
 an ion gate upstream of said electrode; and
 control means for switching said ion gate between a first mode and a second mode, said second mode having a lower ion transmission efficiency than said first mode, wherein in a mode of operation said control means:

- (i) switches said ion gate from said second mode to said first mode at a time T_2 ; and
- (ii) causes said electrode to inject or orthogonally accelerate ions into said drift region at a later time $T_2 + \Delta T_2$;

wherein ΔT_2 is set such that ions having a mass to charge ratio \geq a value M3 are not substantially injected or orthogonally accelerated into said drift region by said electrode.

2. A mass spectrometer as claimed in claim 1, wherein ions having a mass to charge ratio \leq a value M3' are substantially injected or orthogonally accelerated into said drift region by said electrode with a first transmission efficiency and ions having a mass to charge ratio in the range M3'-M3 are substantially injected or orthogonally accelerated into said drift region by said electrode with a second transmission efficiency lower than said first transmission efficiency, wherein M3' $<$ M3.

3. A mass spectrometer as claimed in claim 2, wherein M3' falls within a range selected from the group consisting of: (i) 1-50; (ii) 50-100; (iii) 100-150; (iv) 150-200; (v) 200-250; (vi) 250-300; (vii) 300-350; (viii) 350-400; (ix) 400-450; (x) 450-500; (xi) 500-550; (xii) 550-600; (xiii) 600-650; (xiv) 650-700; (xv) 700-750; (xvi) 750-800; (xvii) 800-850; (xviii) 850-900; (xix) 900-950; (xx) 950-1000; (xxi) 1000-1500; (xxii) 1500-2000; (xxiii) 2000-2500; (xxiv) 2500-3000; and (xxv) $>$ 3000.

4. A mass spectrometer as claimed in claim 1, 2 or 3, wherein ΔT_2 falls within a range selected from the group consisting of: (i) 0.1-1 μ s; (ii) 1-5 μ s; (iii) 5-10 μ s; (iv) 10-15 μ s; (v) 15-20 μ s; (vi) 20-50 μ s; (vii) 50-100 μ s; (viii) 100-500 μ s; and (ix) 500-1000 μ s.

5. A mass spectrometer as claimed in any preceding claim, wherein M3 falls within a range selected from the group consisting of: (i) 1-50; (ii) 50-100; (iii)

- 100-150; (iv) 150-200; (v) 200-250; (vi) 250-300; (vii) 300-350; (viii) 350-400; (ix) 400-450; (x) 450-500; (xi) 500-550; (xii) 550-600; (xiii) 600-650; (xiv) 650-700; (xv) 700-750; (xvi) 750-800; (xvii) 800-850; (xviii) 850-900; (xix) 900-950; (xx) 950-1000; (xxi) 1000-1500; (xxii) 1500-2000; (xxiii) 2000-2500; (xxiv) 2500-3000; and (xxv) > 3000.
6. A mass spectrometer as claimed in any preceding claim, wherein immediately after said control means has caused said electrode to inject or orthogonally accelerate ions into said drift region at time $T_2 + \Delta T_2$ said control means switches said ion gate from said first mode to said second mode.
7. A mass spectrometer comprising:
- an ion source;
 - an orthogonal acceleration Time of Flight mass analyser comprising an electrode for orthogonally accelerating ions, an ion detector and a drift region therebetween;
 - an ion gate upstream of said electrode; and
 - control means for switching said ion gate between a first mode and a second mode, said second mode having a lower ion transmission efficiency than said first mode, wherein in a mode of operation said control means:
 - (i) switches said ion gate from said second mode to said first mode at a time T_3 ;
 - (ii) switches said ion gate from said first mode to said second mode at a later time $T_3 + \delta T_3$; and
 - (iii) causes said electrode to inject or orthogonally accelerate ions into said drift region at a yet later time $T_3 + \delta T_3 + \Delta T_3$;
- wherein δT_3 and ΔT_3 are set such that ions having a mass to charge ratio \leq a value M1 are not substantially injected or orthogonally accelerated into said drift region by said electrode and such that ions having a mass to charge ratio \geq a value M3 are not substantially injected or orthogonally accelerated into said drift region by said electrode, wherein $M1 < M3$.
8. A mass spectrometer as claimed in claim 7, wherein ions having a mass to charge ratio M2 are substantially injected or orthogonally accelerated into said drift region by said electrode with a first transmission efficiency and other ions having a mass to charge ratio in the range M1-M3 are substantially injected or orthogonally accelerated into said drift region by said electrode with a second transmission efficiency lower than said first transmission efficiency, wherein $M1 < M2 < M3$.
9. A mass spectrometer as claimed in claim 8, wherein M2 falls within a range selected from the group consisting of: (i) 1-50; (ii) 50-100; (iii) 100-150; (iv) 150-200; (v) 200-250; (vi) 250-300; (vii) 300-350; (viii) 350-400; (ix) 400-450; (x) 450-500; (xi) 500-550; (xii) 550-600; (xiii) 600-650; (xiv) 650-700; (xv) 700-750; (xvi) 750-800; (xvii) 800-850; (xviii) 850-900; (xix) 900-950; (xx) 950-1000; (xxi) 1000-1500; (xxii) 1500-2000; (xxiii) 2000-2500; (xxiv) 2500-3000; and (xxv) > 3000.
10. A mass spectrometer as claimed in claim 7, wherein ions having a mass to charge ratio in a range M1'-M3' are substantially injected or orthogonally accelerated into said drift region by said electrode with a first transmission efficiency and ions having a mass to charge ratio in the range M1-M1' and M3'-M3 are substantially injected or orthogonally accelerated into said drift region by said electrode with a second transmission efficiency lower than said first transmission efficiency, wherein $M1 < M1' < M3' < M3$.
11. A mass spectrometer as claimed in claim 10, wherein M1' falls within a range selected from the group consisting of: (i) 1-50; (ii) 50-100; (iii) 100-150; (iv) 150-200; (v) 200-250; (vi) 250-300; (vii) 300-350; (viii) 350-400; (ix) 400-450; (x) 450-500; (xi) 500-550; (xii) 550-600; (xiii) 600-650; (xiv) 650-700; (xv) 700-750; (xvi) 750-800; (xvii) 800-850; (xviii) 850-900; (xix) 900-950; (xx) 950-1000; (xxi) 1000-1500; (xxii) 1500-2000; (xxiii) 2000-2500; (xxiv) 2500-3000; and (xxv) > 3000.
12. A mass spectrometer as claimed in claim 10 or 11, wherein M3' falls within a range selected from the group Consisting of: (i) 1-50; (ii) 50-100; (iii) 100-150; (iv) 150-200; (v) 200-250; (vi) 250-300; (vii) 300-350; (viii) 350-400; (ix) 400-450; (x) 450-500; (xi) 500-550; (xii) 550-600; (xiii) 600-650; (xiv) 650-700; (xv) 700-750; (xvi) 750-800; (xvii) 800-850; (xviii) 850-900; (xix) 900-950; (xx) 950-1000; (xxi) 1000-1500; (xxii) 1500-2000; (xxiii) 2000-2500; (xxiv) 2500-3000; and (xxv) > 3000.
13. A mass spectrometer as claimed in any of claims 7-12, wherein δT_3 falls within a range selected from the group consisting of: (i) 0.1-1 μ s; (ii) 1-5 μ s; (iii) 5-10 μ s; (iv) 10-15 μ s; (v) 15-20 μ s; (vi) 20-50 μ s; (vii) 50-100 μ s; (viii) 100-500 μ s; and (ix) 500-1000 μ s.
14. A mass spectrometer as claimed in any of claims 7-13, wherein ΔT_3 falls within a range selected from the group consisting of: (i) 0.1-1 μ s; (ii) 1-5 μ s; (iii) 5-10 μ s; (iv) 10-15 μ s; (v) 15-20 μ s; (vi) 20-50 μ s; (vii) 50-100 μ s; (viii) 100-500 μ s; and (ix) 500-1000 μ s.

15. A mass spectrometer as claimed in any of claims 7-14, wherein M1 falls within a range selected from the group consisting of: (i) 1-5; (ii) 5-10; (iii) 10-15; (iv) 15-20; (v) 20-25; (vi) 25-30; (vii) 30-35; (viii) 35-40; (ix) 40-45; (x) 45-50; (xi) 50-55; (xii) 55-60; (xiii) 60-65; (xiv) 65-70; (xv) 70-75; (xvi) 75-100; (xvii) 100-150; (xviii) 150-200; (xix) 200-250; (xx) 250-300; (xxi) 300-350; (xxii) 350-400; (xxiii) 400-450; (xxiv) 450-500; (xxv) 500-550; (xxvi) 550-600; (xxvii) 600-650; (xxviii) 650-700; (xxix) 700-750; (xxx) 750-800; (xxxi) 800-850; (xxxii) 850-900; (xxxiii) 900-950; (xxxiv) 950-1000; and (xxxv) > 1000.
16. A mass spectrometer as claimed in any of claims 7-15, wherein M3 falls within a range selected from the group consisting of: (i) 1-50; (ii) 50-100; (iii) 100-150; (iv) 150-200; (v) 200-250; (vi) 250-300; (vii) 300-350; (viii) 350-400; (ix) 400-450; (x) 450-500; (xi) 500-550; (xii) 550-600; (xiii) 600-650; (xiv) 650-700; (xv) 700-750; (xvi) 750-800; (xvii) 800-850; (xviii) 850-900; (xix) 900-950; (xx) 950-1000; (xxi) 1000-1500; (xxii) 1500-2000; (xxiii) 2000-2500; (xxiv) 2500-3000; and (xxv) > 3000.
17. A mass spectrometer comprising:
- an ion source;
 - an orthogonal acceleration Time of Flight mass analyser comprising an electrode for orthogonally accelerating ions, an ion detector and a drift region therebetween;
 - an ion gate upstream of said electrode; and
 - control means for switching said ion gate between a first mode and a second mode, said second mode having a lower ion transmission efficiency than said first mode, wherein in a mode of operation said control means:
 - (i) switches said ion gate from said first mode to said second mode at a time T_4 ;
 - (ii) switches said ion gate from said second mode to said first mode at a later time $T_4 + \delta T_4$; and
 - (iii) causes said electrode to inject or orthogonally accelerate ions into said drift region at a yet later time $T_4 + \delta T_4 + \Delta T_4$;
- wherein δT_4 and ΔT_4 are set such that ions having a mass to charge ratio equal to a value M2 are not substantially injected or orthogonally accelerated into said drift region by said electrode.
18. A mass spectrometer as claimed in claim 17, wherein M2 falls within a range selected from the group consisting of: (i) 1-50; (ii) 50-100; (iii) 100-150; (iv) 150-200; (v) 200-250; (vi) 250-300; (vii) 300-350; (viii) 350-400; (ix) 400-450; (x) 450-500; (xi) 500-550; (xii) 550-600; (xiii) 600-650; (xiv) 650-700; (xv) 700-750; (xvi) 750-800; (xvii) 800-850; (xviii) 850-900; (xix) 900-950; (xx) 950-1000; (xxi) 1000-1500; (xxii) 1500-2000; (xxiii) 2000-2500; (xxiv) 2500-3000; and (xxv) > 3000.
19. A mass spectrometer as claimed in claim 17 or 18, wherein ions having a mass to charge ratio \leq a value M1 and ions having a mass to charge ratio \geq a value M3 are substantially injected or orthogonally accelerated into said drift region by said electrode with a first transmission efficiency, and wherein ions having a mass to charge in the range M1-M3 are substantially injected or orthogonally accelerated into said drift region by said electrode with a second transmission efficiency lower than said first transmission efficiency, wherein $M1 < M2 < M3$.
20. A mass spectrometer comprising:
- an ion source;
 - an orthogonal acceleration Time of Flight mass analyser comprising an electrode for orthogonally accelerating ions, an ion detector and a drift region therebetween;
 - an ion gate upstream of said electrode; and
 - control means for switching said ion gate between a first mode and a second mode, said second mode having a lower ion transmission efficiency than said first mode, wherein in a mode of operation said control means:
 - (i) switches said ion gate from said first mode to said second mode at a time T_4 ;
 - (ii) switches said ion gate from said second mode to said first mode at a later time $T_4 + \delta T_4$; and
 - (iii) causes said electrode to inject or orthogonally accelerate ions into said drift region at a yet later time $T_4 + \delta T_4 + \Delta T_4$;
- wherein δT_4 and ΔT_4 are set such that ions having a mass to charge ratio in a range M1'-M3' are not substantially injected or orthogonally accelerated into said drift region by said electrode, wherein $M1' < M3'$.
21. A mass spectrometer as claimed in claim 20, wherein M1' falls within a range selected from the group consisting of: (i) 1-50; (ii) 50-100; (iii) 100-150; (iv) 150-200; (v) 200-250; (vi) 250-300; (vii) 300-350; (viii) 350-400; (ix) 400-450; (x) 450-500; (xi) 500-550; (xii) 550-600; (xiii) 600-650; (xiv) 650-700; (xv) 700-750; (xvi) 750-800; (xvii) 800-850; (xviii) 850-900; (xix) 900-950; (xx) 950-1000; (xxi) 1000-1500; (xxii) 1500-2000; (xxiii) 2000-2500; (xxiv) 2500-3000; and (xxv) > 3000.
22. A mass spectrometer as claimed in claim 20 or 21,

- wherein M3' falls within a range selected from the group consisting of: (i) 1-50; (ii) 50-100; (iii) 100-150; (iv) 150-200; (v) 200-250; (vi) 250-300; (vii) 300-350; (viii) 350-400; (ix) 400-450; (x) 450-500; (xi) 500-550; (xii) 550-600; (xiii) 600-650; (xiv) 650-700; (xv) 700-750; (xvi) 750-800; (xvii) 800-850; (xviii) 850-900; (xix) 900-950; (xx) 950-1000; (xxi) 1000-1500; (xxii) 1500-2000; (xxiii) 2000-2500; (xxiv) 2500-3000; and (xxv) > 3000.
23. A mass spectrometer as claimed in claim 20, 21 or 22, wherein ions having a mass to charge ratio \leq a value M1 and ions having a mass to charge ratio \geq a value M3 are substantially injected or orthogonally accelerated into said drift region by said electrode with a first transmission efficiency and ions having a mass to charge ratio in the range M1-M1' and ions having a mass to charge ratio in the range M3'-M3 are substantially injected or orthogonally accelerated into said drift region by said electrode with a second transmission efficiency lower than said first transmission efficiency, wherein $M1 < M1' < M3' < M3$.
24. A mass spectrometer as claimed in claim 19 or 23, wherein M1 falls within a range selected from the group consisting of: (i) 1-5; (ii) 5-10; (iii) 10-15; (iv) 15-20; (v) 20-25; (vi) 25-30; (vii) 30-35; (viii) 35-40; (ix) 40-45; (x) 45-50; (xi) 50-55; (xii) 55-60; (xiii) 60-65; (xiv) 65-70; (xv) 70-75; (xvi) 75-100; (xvii) 100-150; (xviii) 150-200; (xix) 200-250; (xx) 250-300; (xxi) 300-350; (xxii) 350-400; (xxiii) 400-450; (xxiv) 450-500; (xxv) 500-550; (xxvi) 550-600; (xxvii) 600-650; (xxviii) 650-700; (xxix) 700-750; (xxx) 750-800; (xxxi) 800-350; (xxxii) 850-900; (xxxiii) 900-950; (xxxiv) 950-1000; and (xxxv) > 1000.
25. A mass spectrometer as claimed in claim 19, 23 or 24, wherein M3 falls within a range selected from the group consisting of (i) 1-50; (ii) 50-100; (iii) 100-150; (iv) 150-200; (v) 200-250; (vi) 250-300; (vii) 300-350; (viii) 350-400; (ix) 400-450; (x) 450-500; (xi) 500-550; (xii) 550-600; (xiii) 600-650; (xiv) 650-700; (xv) 700-750; (xvi) 750-800; (xvii) 800-850; (xviii) 850-900; (xix) 900-950; (xx) 950-1000; (xxi) 1000-1500; (xxii) 1500-2000; (xxiii) 2000-2500; (xxiv) 2500-3000; and (xxv) > 3000.
26. A mass spectrometer as claimed in any of claims 17-25, wherein δT_4 falls within a range selected from the group consisting of: (i) 0.1-1 μ s; (ii) 1-5 μ s; (iii) 5-10 μ s; (iv) 10-15 μ s; (v) 15-20 μ s; (vi) 20-50 μ s; (vii) 50-100 μ s; (viii) 100-500 μ s; and (ix) 500-1000 μ s.
27. A mass spectrometer as claimed in any of claims 17-26, wherein ΔT_4 falls within a range selected from the group consisting of: (i) 0.1-1 μ s; (ii) 1-5 μ s; (iii) 5-10 μ s; (iv) 10-15 μ s; (v) 15-20 μ s; (vi) 20-50 μ s; (vii) 50-100 μ s; (viii) 100-500 μ s; and (ix) 500-1000 μ s.
28. A mass spectrometer as claimed in any preceding claim, wherein said electrode comprises a pusher and/or puller electrode.
29. A mass spectrometer as claimed in any preceding claim, wherein said ion gate comprises one or more electrodes for altering, deflecting, reflecting, defocusing, attenuating or blocking a beam of ions.
30. A mass spectrometer as claimed in any preceding claim, wherein in said second mode said ion transmission efficiency is substantially 0%.
31. A mass spectrometer as claimed in any of claims 1-29, wherein in said second mode said ion transmission efficiency is # x% of the ion transmission efficiency in said first mode, wherein x falls within a range selected from the group consisting of: (i) 0.001-0.01; (ii) 0.01-0.1; (iii) 0.1-1; (iv) 1-10; and (v) 10-90.
32. A mass spectrometer as claimed in any preceding claim, wherein said electrode is repeatedly energised with a frequency selected from the group consisting of: (i) 100-500 Hz; (ii) 0.5-1 kHz; (iii) 1-5 kHz; (iv) 5-10 kHz; (v) 10-20 kHz; (vi) 20-30 kHz; (vii) 30-40 kHz; (viii) 40-50 kHz; (ix) 50-60 kHz; (x) 60-70 kHz; (xi) 70-80 kHz; (xii) 80-90 kHz; (xiii) 90-100 kHz; (xiv) 100-500 kHz; (xv) 0.5-1 MHz; and (xvi) > 1 MHz.
33. A mass spectrometer as claimed in any preceding claim, wherein said ion source comprises a continuous ion source.
34. A mass spectrometer as claimed in claim 33, wherein said ion source is selected from the group consisting of: (i) an Electron Impact ("EI") ion source; (ii) a Chemical Ionisation ("CI") ion source; (iii) a Field Ionisation ("FI") ion source; (iv) an Electrospray ion source; (v) an Atmospheric Pressure Chemical Ionisation ("APCI") ion source; (vi) an Inductively Coupled Plasma ("ICP") ion source; (vii) an Atmospheric Pressure Photo Ionisation ("APPI") ion source; (viii) a Fast Atom Bombardment ("FAB") ion source; and (ix) a Liquid Secondary Ions Mass Spectrometry ("LSIMS") ion source.
35. A mass spectrometer as claimed in any of claims 1-32, wherein said ion source is a pseudo-continuous ion source.
36. A mass spectrometer as claimed in claim 35, wherein said ion source is selected from the group consisting of: (i) a Matrix Assisted Laser Desorption Ionisation

("MALDI") ion source; and (ii) a Laser Desorption Ionisation ("LDI") ion source.

37. A mass spectrometer as claimed in claim 36, further comprising an RF ion guide comprising a collision gas for dispersing a packet of ions emitted by said ion source.

38. A mass spectrometer as claimed in any preceding claim, wherein said ion source is coupled to a liquid chromatography source.

39. A mass spectrometer as claimed in any of claims 1-37, wherein said ion source is coupled to a gas chromatography source.

40. A method of mass spectrometry, comprising:

switching an ion gate from a second mode to a first mode at a time T_2 , said second mode having a lower ion transmission efficiency than said first mode; and

injecting or orthogonally accelerating ions into a drift region of an orthogonal acceleration Time of Flight mass analyser at a later time $T_2 + \Delta T_2$; wherein ΔT_2 is set such that ions having a mass to charge ratio \geq a value M3 are not substantially injected or orthogonally accelerated into said drift region.

41. A method of mass spectrometry, comprising:

switching an ion gate from a second mode to a first mode at a time T_3 , said second mode having a lower ion transmission efficiency than said first mode;

switching said ion gate from said first mode to said second mode at a later time $T_3 + \delta T_3$; and injecting or orthogonally accelerating ions into a drift region of an orthogonal acceleration Time of Flight mass analyser at a yet later time $T_3 + \delta T_3 + \Delta T_3$;

wherein δT_3 and ΔT_3 are set such that ions having a mass to charge ratio \leq a value M1 are not substantially injected or orthogonally accelerated into said drift region and such that ions having a mass to charge ratio \geq a value M3 are not substantially injected or orthogonally accelerated into said drift region, wherein $M1 < M3$.

42. A method of mass spectrometry, comprising:

switching an ion gate from a first mode to a second mode at a time T_4 , said second mode having a lower ion transmission efficiency than said first mode;

switching said ion gate from said second mode to said first mode at a later time $T_4 + \delta T_4$; and

injecting or orthogonally accelerating ions into a drift region of an orthogonal acceleration Time of Flight mass analyser at a yet later time $T_4 + \delta T_4 + \Delta T_4$;

wherein δT_4 and ΔT_4 are set such that ions having a mass to charge ratio equal to a value M2 are not substantially injected or orthogonally accelerated into said drift region.

43. A method of mass spectrometry, comprising:

switching an ion gate from a first mode to a second mode at a time T_4 , said second mode having a lower ion transmission efficiency than said first mode;

switching said ion gate from said second mode to said first mode at a later time $T_4 + \delta T_4$; and injecting or orthogonally accelerating ions into a drift region of an orthogonal acceleration Time of Flight mass analyser at a yet later time $T_4 + \delta T_4 + \Delta T_4$;

wherein δT_4 and ΔT_4 are set such that ions having a mass to charge ratio in a range M1'-M3' are not substantially injected or orthogonally accelerated into said drift region, wherein $M1' < M3'$.

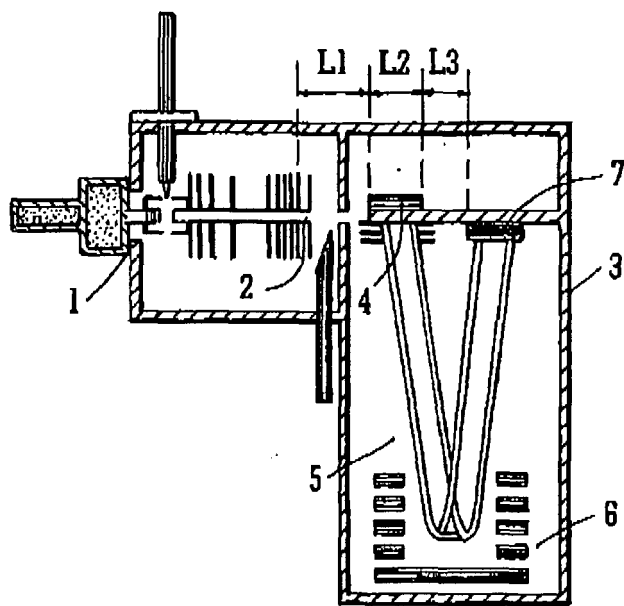

FIG. 1

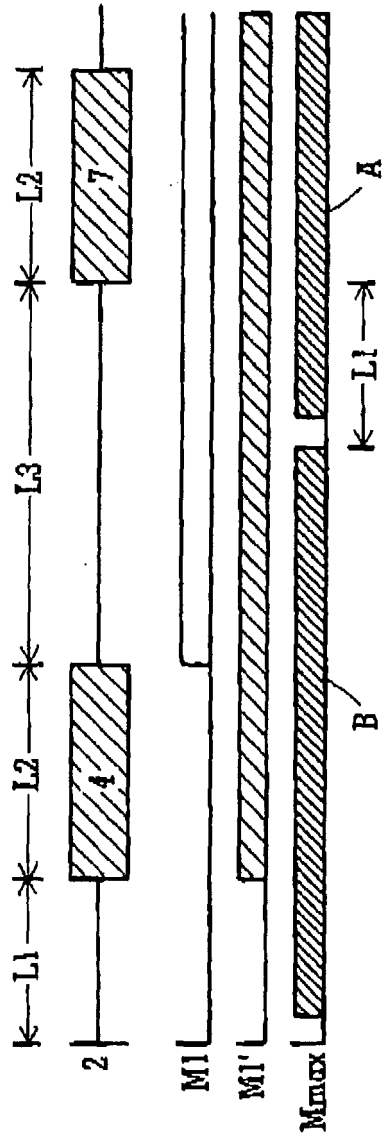
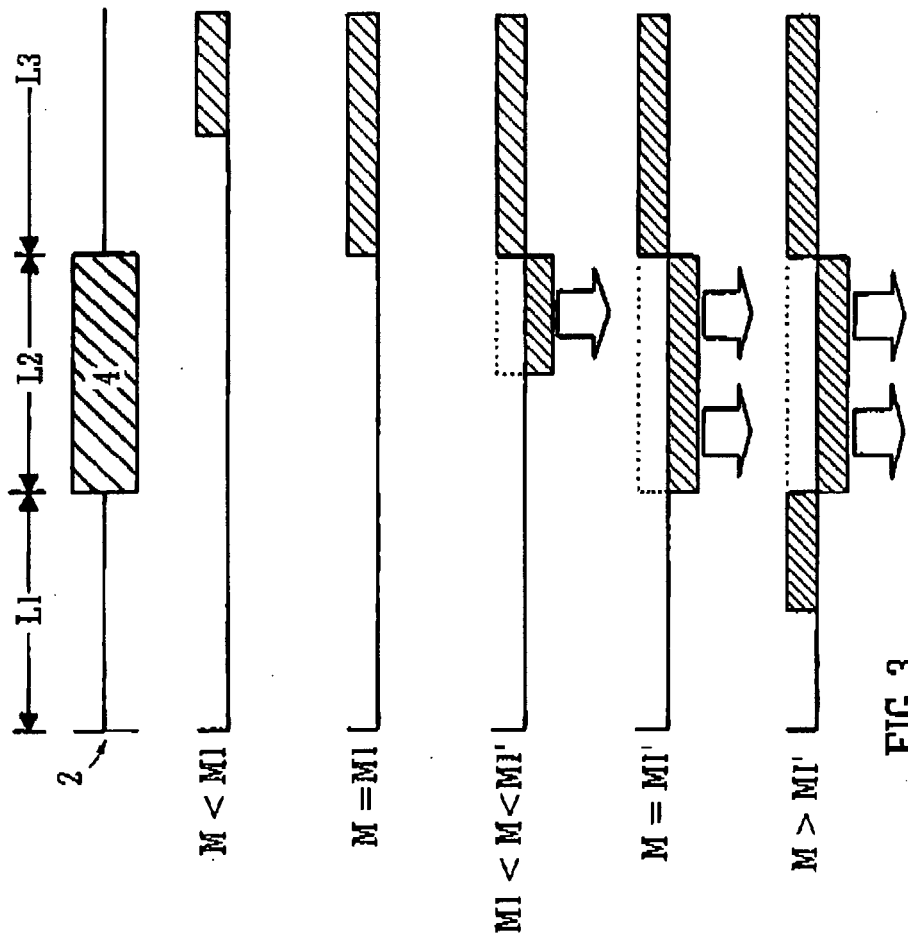
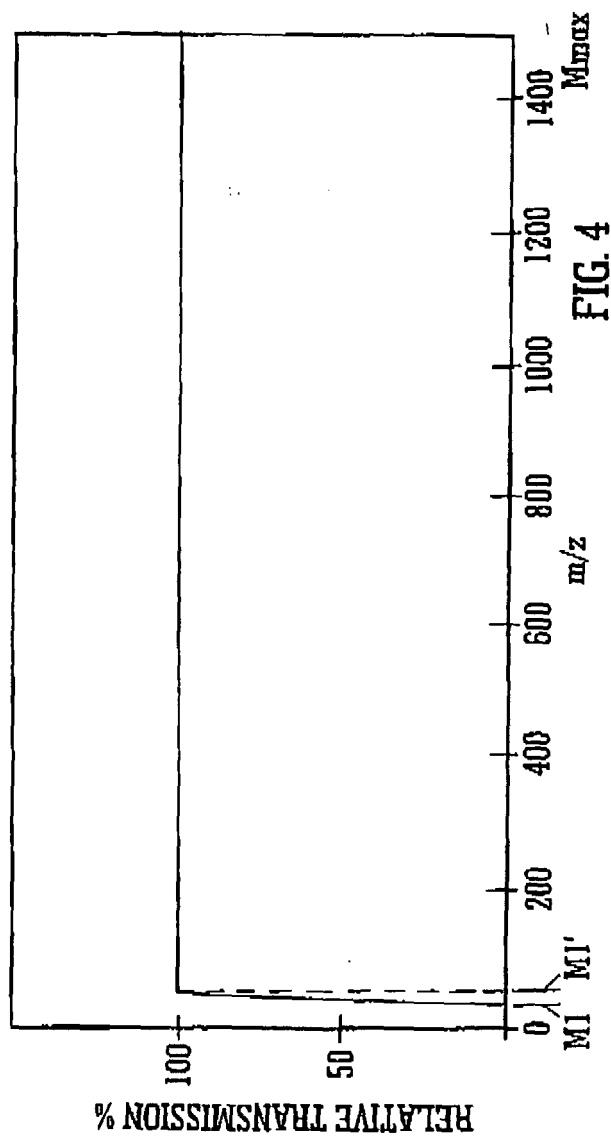

FIG. 2





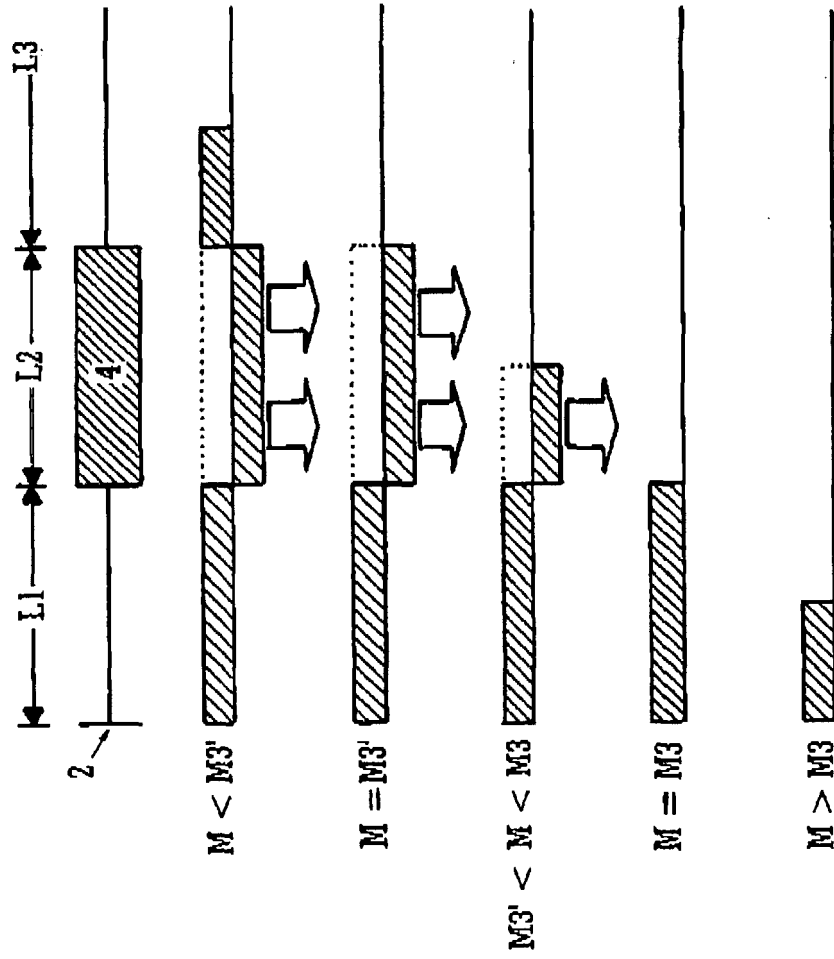

FIG. 5

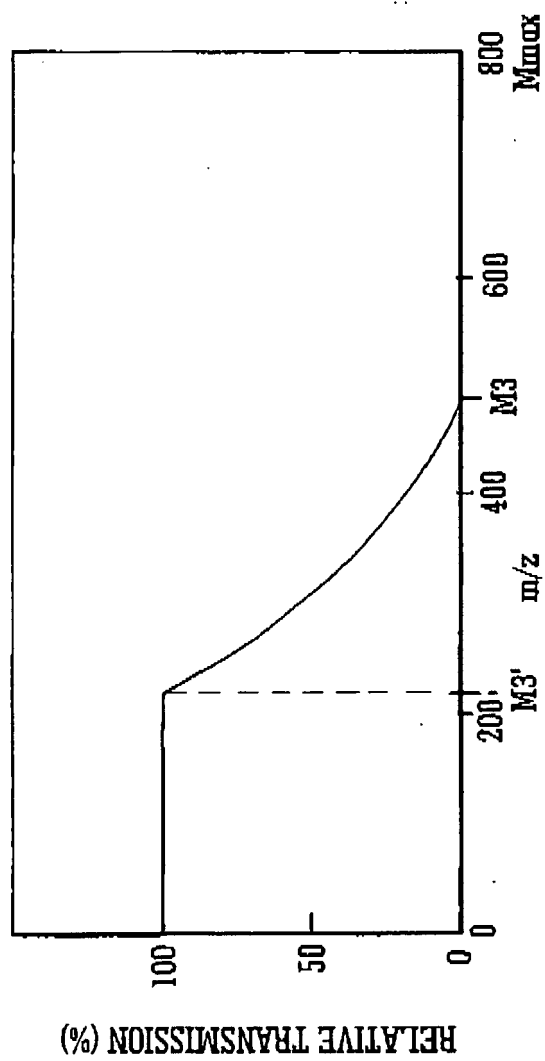

FIG. 6

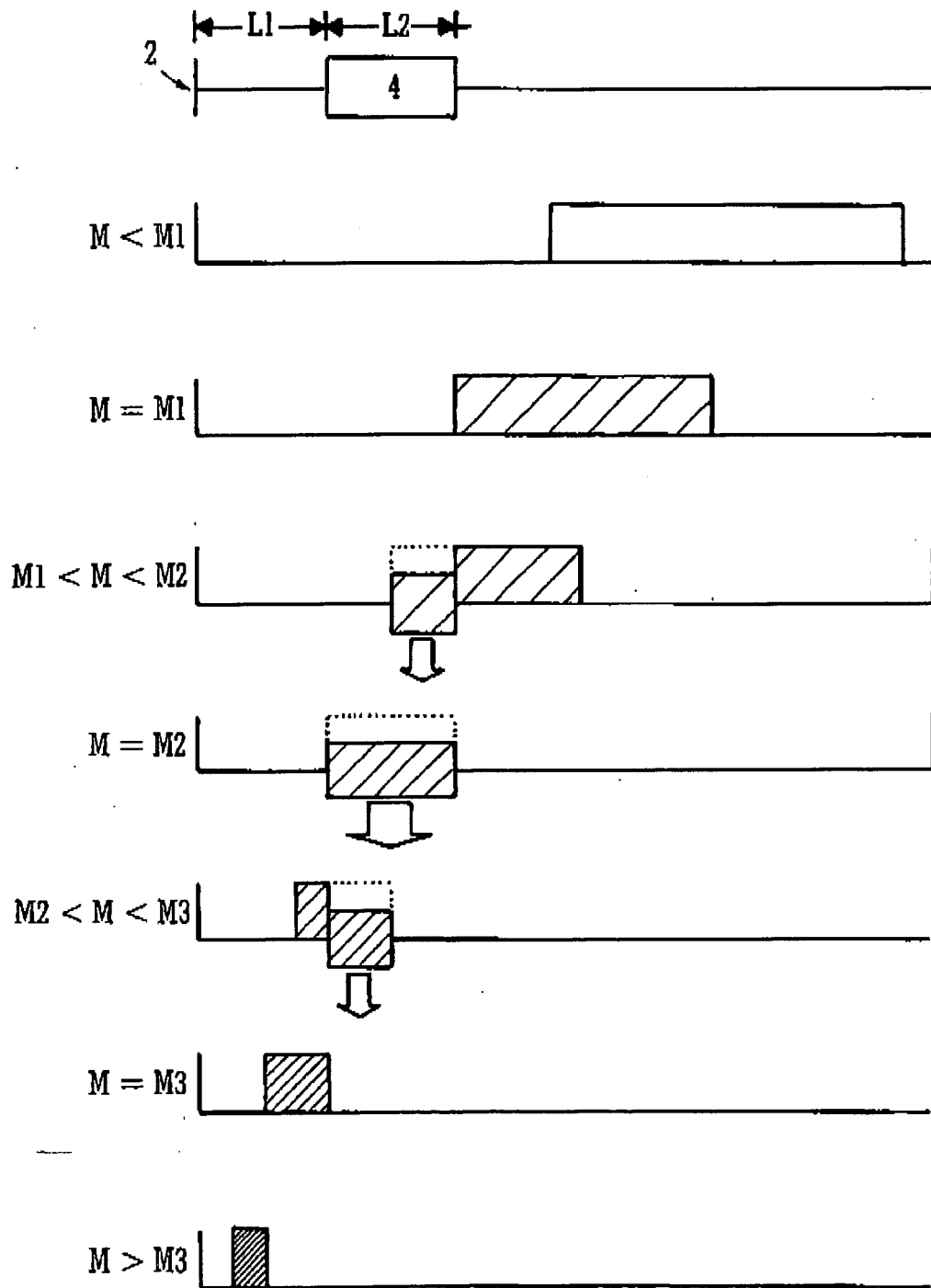

FIG. 7

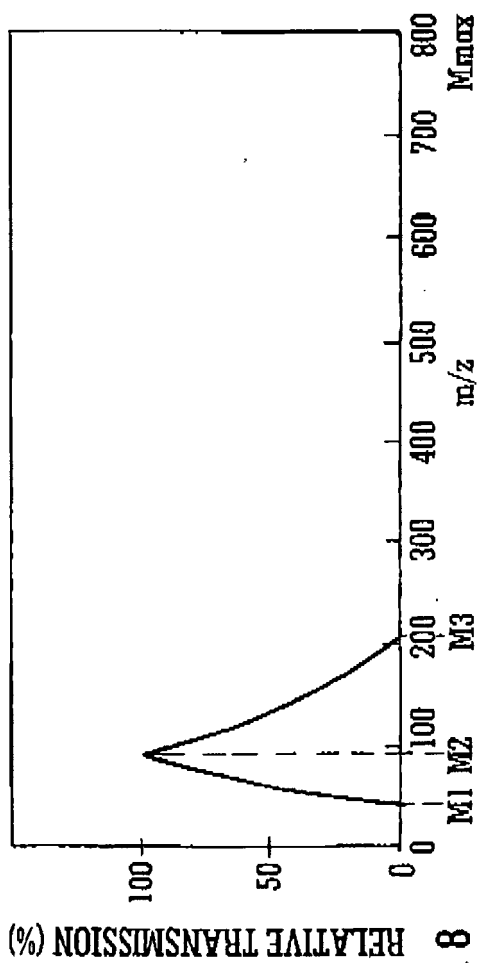

FIG. 8

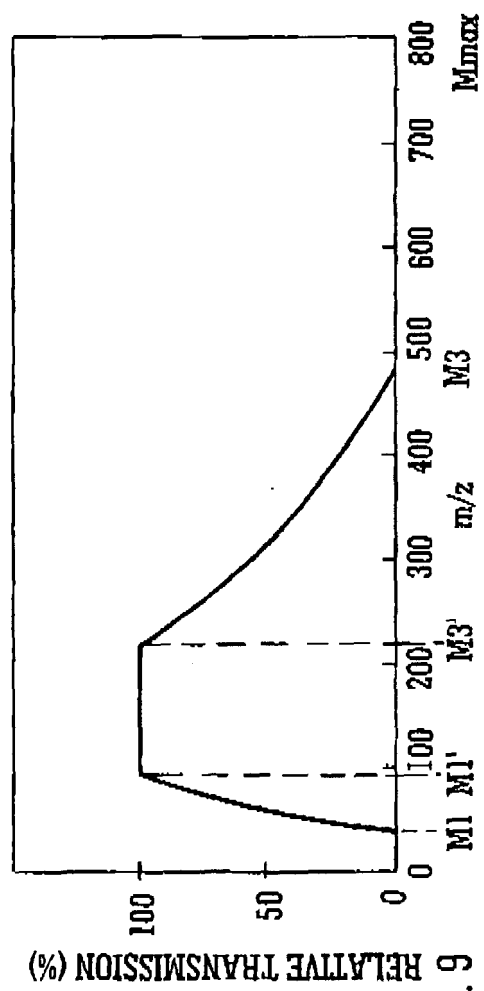

FIG. 9

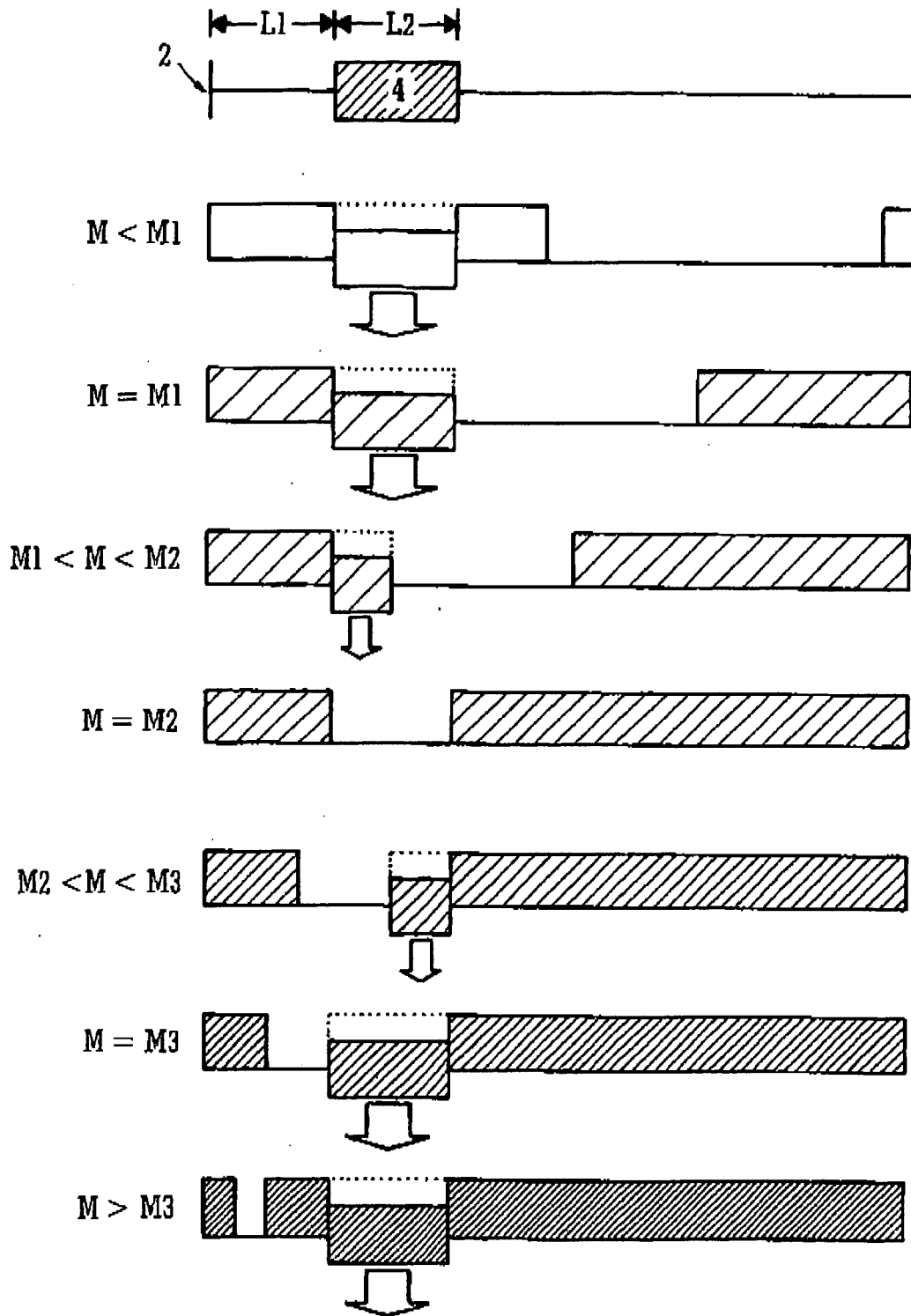

FIG. 10

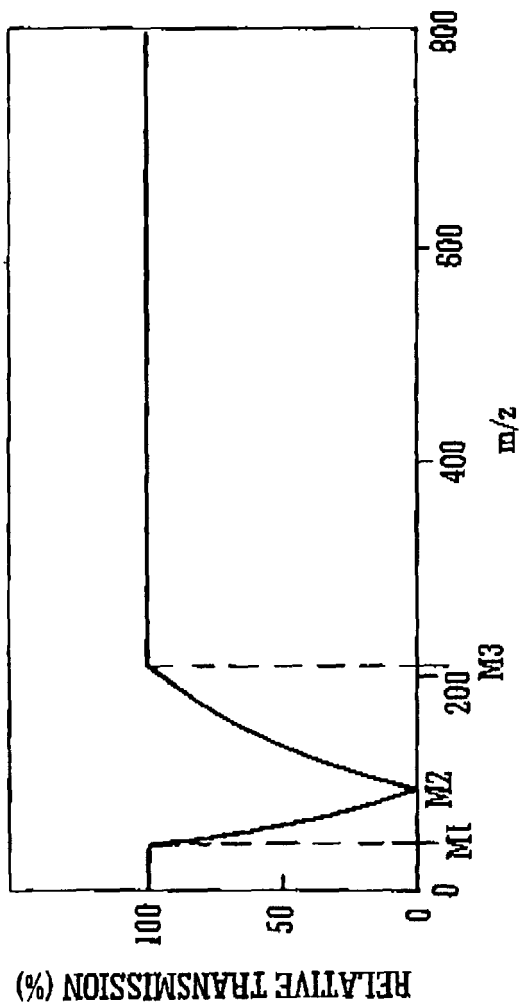

FIG. 11

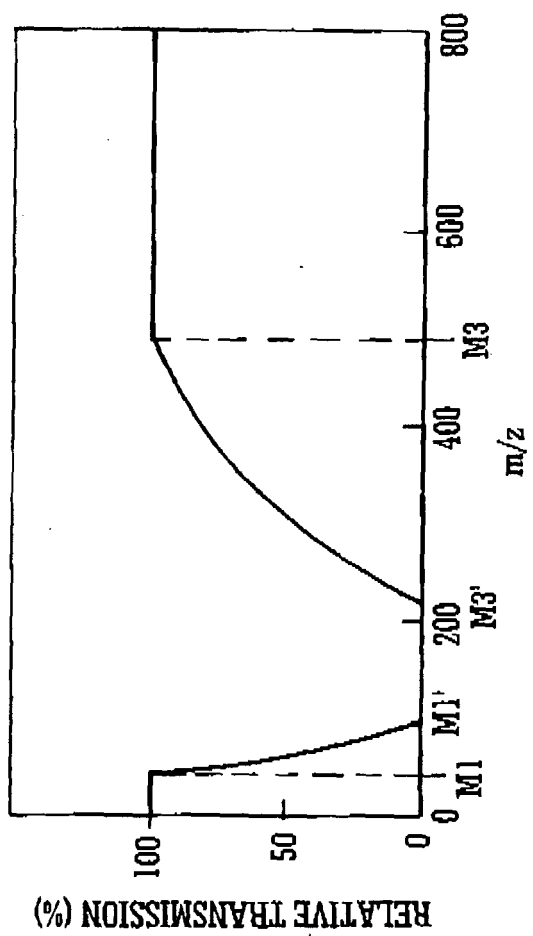

FIG. 12

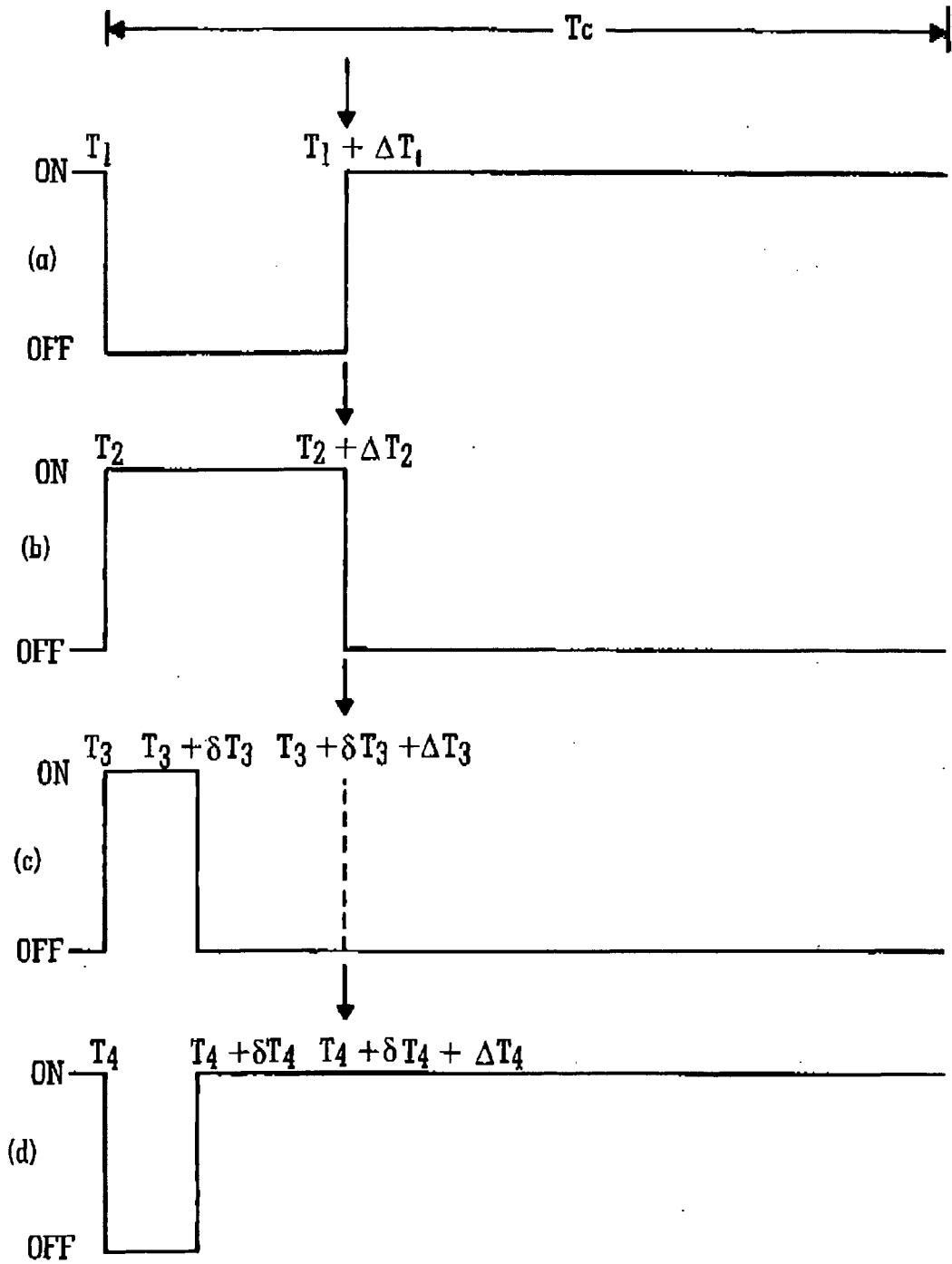

FIG. 13

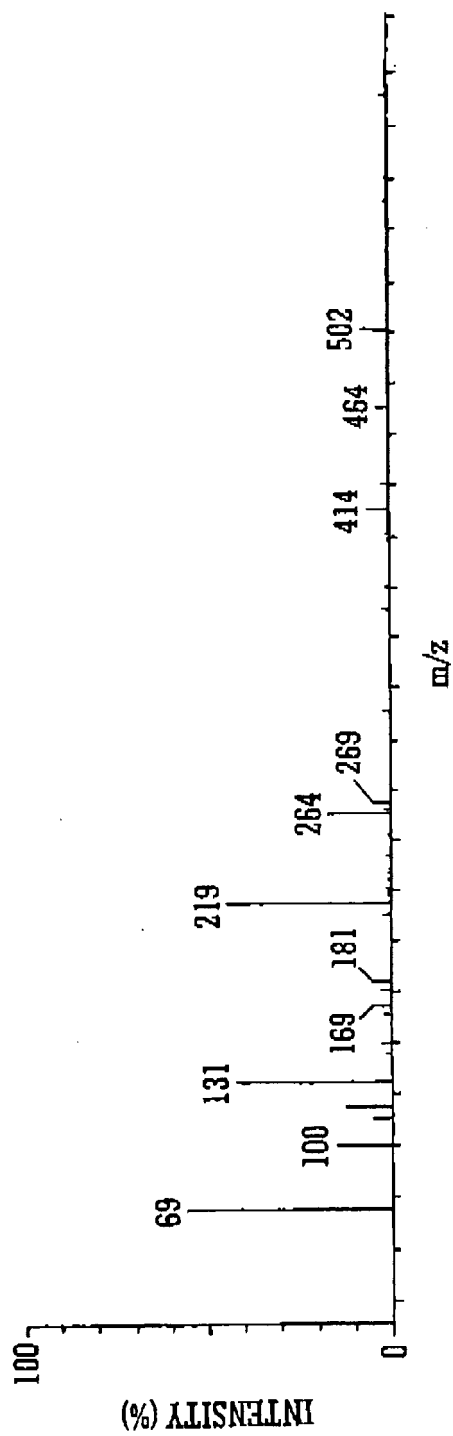

FIG. 14A

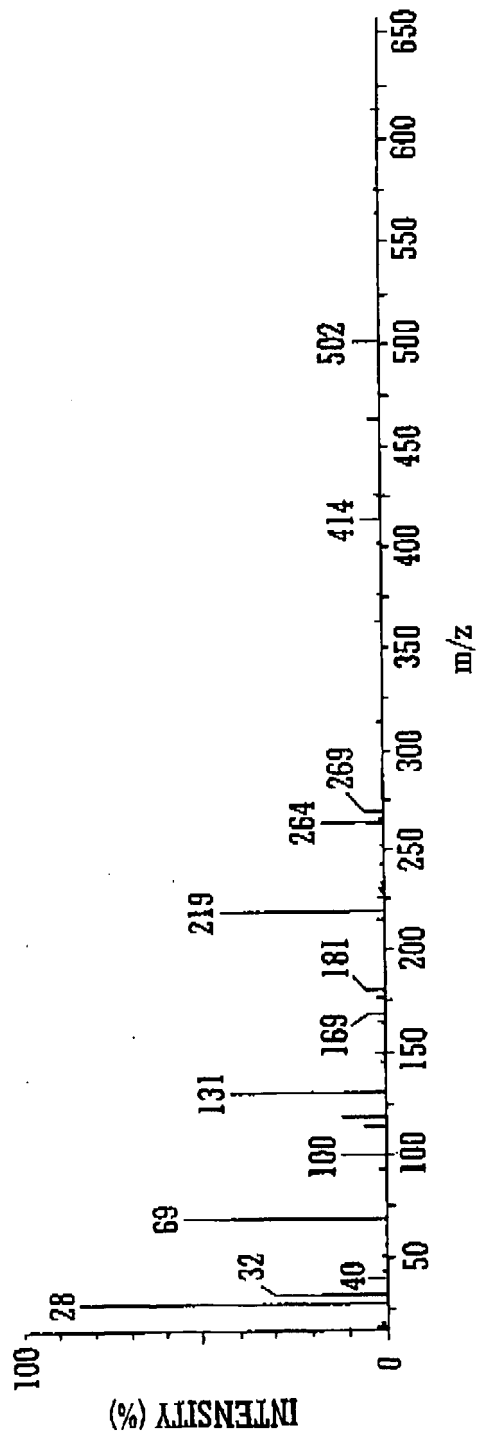

FIG. 14B

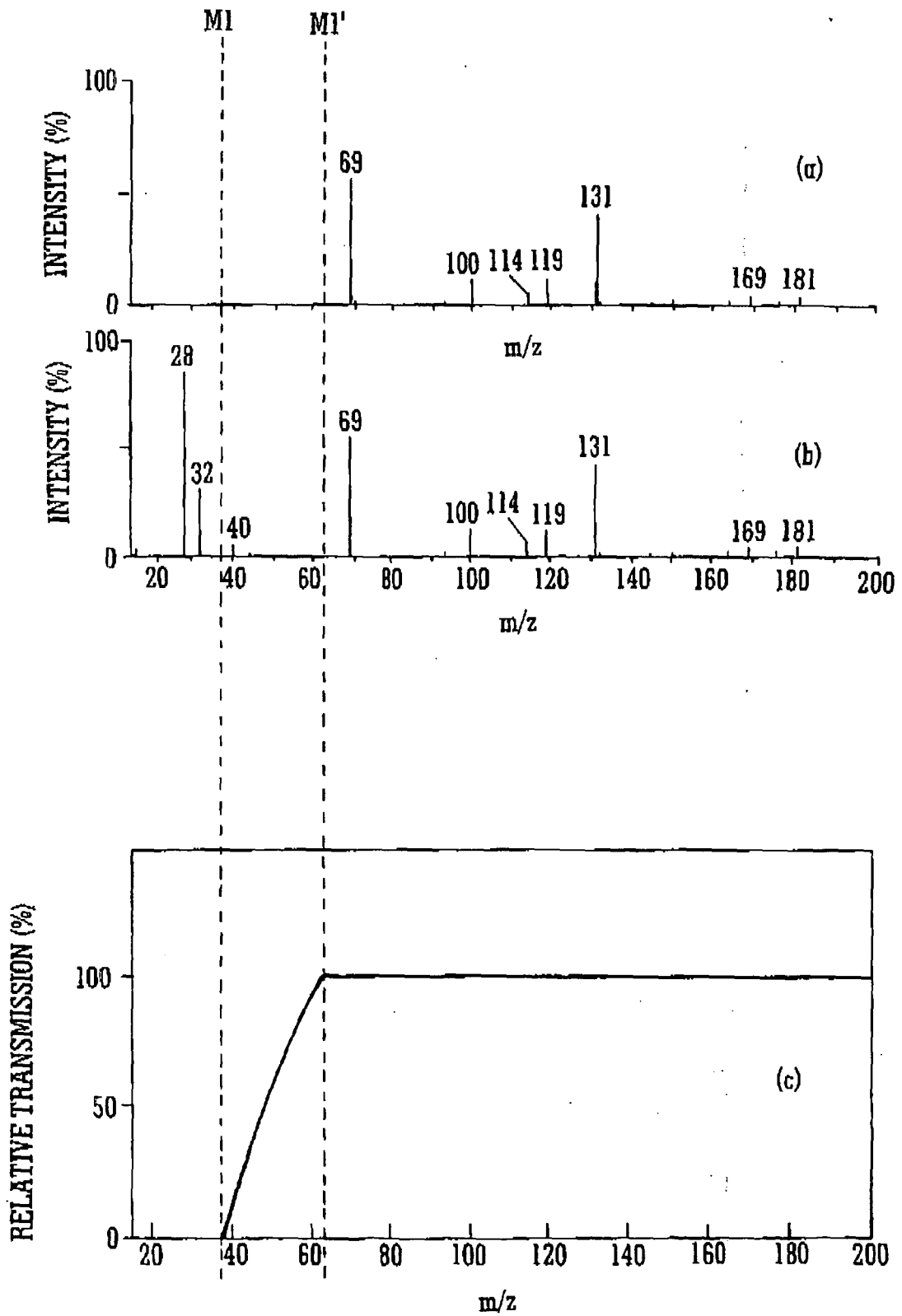

FIG. 15

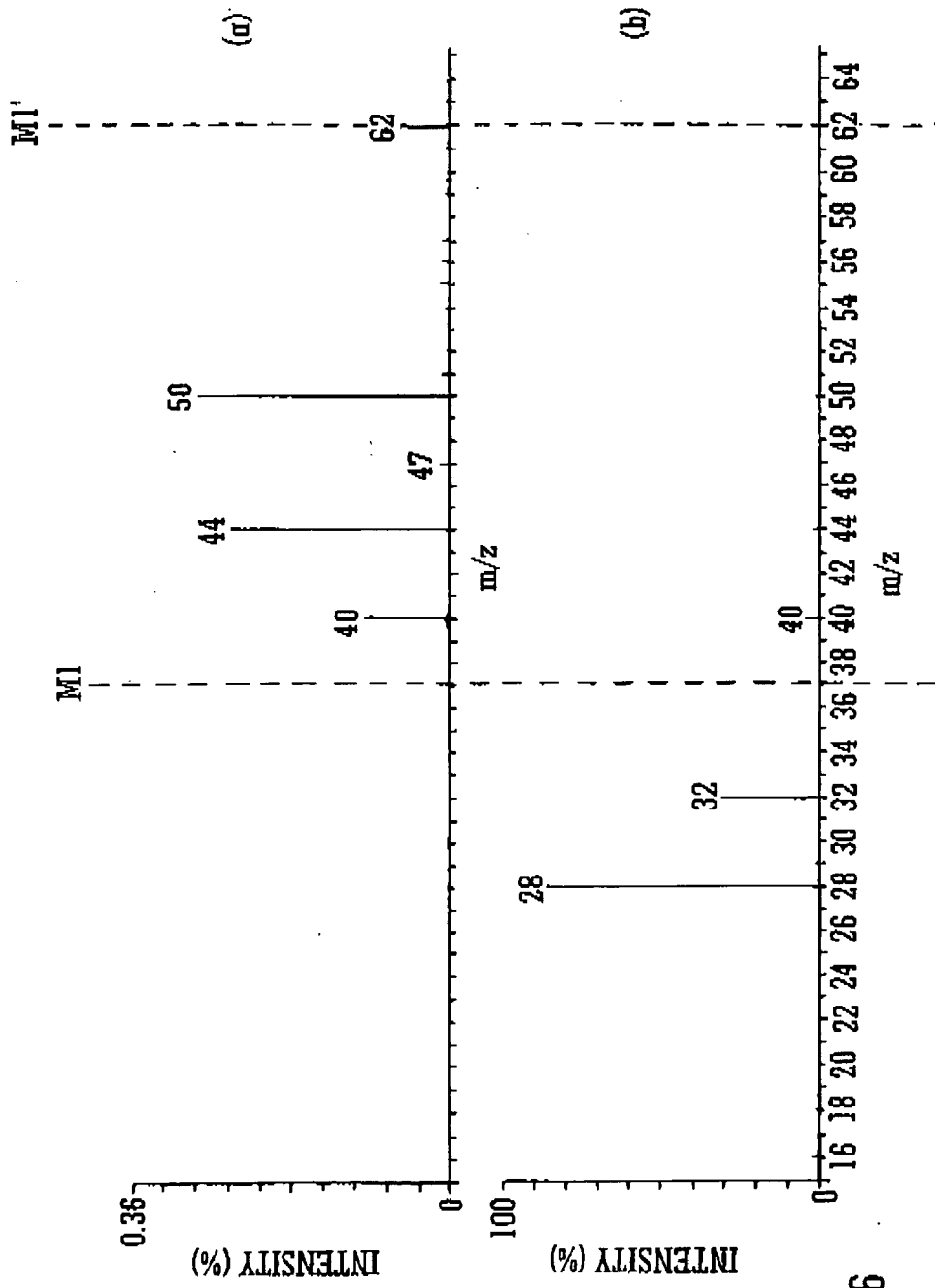

FIG. 16



DOCUMENTS CONSIDERED TO BE RELEVANT			
Category	Citation of document with indication, where appropriate, of relevant passages	Relevant to claim	CLASSIFICATION OF THE APPLICATION (IPC)
X	US 5 689 111 A (DRESCH THOMAS [DE] ET AL) 18 November 1997 (1997-11-18) * the whole document *	1-43	INV. H01J49/40
A	----- US 6 040 575 A (ANDRIEN JR BRUCE A ET AL) 21 March 2000 (2000-03-21) * column 20, paragraphs 2,3 *	1-43	
A	----- LIMBERG G ET AL: "Quantification of the amount of galacturonic acid residues in blocksequences in pectin homogalacturonan by enzymatic fingerprinting with exo- and endo-polygalacturonase II from Aspergillus niger" CARBOHYDRATE RESEARCH, ELSEVIER SCIENTIFIC PUBLISHING COMPANY. AMSTERDAM, NL, vol. 327, no. 3, 24 July 2000 (2000-07-24), pages 321-332, XP004228873 ISSN: 0008-6215 * page 331, paragraph 3 *	1-43	
The present search report has been drawn up for all claims			TECHNICAL FIELDS SEARCHED (IPC)
			H01J
Place of search		Date of completion of the search	Examiner
The Hague		28 February 2007	Loiseleur, Pierre
CATEGORY OF CITED DOCUMENTS			
X : particularly relevant if taken alone		T : theory or principle underlying the invention	
Y : particularly relevant if combined with another document of the same category		E : earlier patent document, but published on, or after the filing date	
A : technological background		D : document cited in the application	
O : non-written disclosure		L : document cited for other reasons	
P : intermediate document		& : member of the same patent family, corresponding document	

**ANNEX TO THE EUROPEAN SEARCH REPORT
ON EUROPEAN PATENT APPLICATION NO.**

EP 06 02 6560

This annex lists the patent family members relating to the patent documents cited in the above-mentioned European search report. The members are as contained in the European Patent Office EDP file on
The European Patent Office is in no way liable for these particulars which are merely given for the purpose of information.

28-02-2007

Patent document cited in search report		Publication date	Patent family member(s)	Publication date
US 5689111	A	18-11-1997	NONE	
US 6040575	A	21-03-2000	US 6204500 B1	20-03-2001

EPO FORM P0459

For more details about this annex : see Official Journal of the European Patent Office, No. 12/82