



(12) **EUROPEAN PATENT APPLICATION**

(43) Date of publication:  
**30.05.2007 Bulletin 2007/22**

(51) Int Cl.:  
**B65D 33/00 (2006.01)**

(21) Application number: **05257325.0**

(22) Date of filing: **29.11.2005**

(84) Designated Contracting States:  
**AT BE BG CH CY CZ DE DK EE ES FI FR GB GR HU IE IS IT LI LT LU LV MC NL PL PT RO SE SI SK TR**  
 Designated Extension States:  
**AL BA HR MK YU**

(71) Applicant: **UNILEVER PLC**  
**London EC4P 4BQ (GB)**

(72) Inventor: **The designation of the inventor has not yet been filed**

(74) Representative: **Cornish, Kristina Victoria Joy et al**  
**Kilburn & Strode**  
**20 Red Lion Street**  
**London WC1R 4PJ (GB)**

(54) **An improved header**

(57) The technical field relates to a header for a multi-compartment pouch-type bag, and a consumer article comprising a header and a multi-compartment pouch-type bag. Particular problems present themselves when a header is attached to a bag comprising a refrigerated or frozen food article, for example hydrolysis of the adhesive bond between the header and bag.

A solution to the aforementioned problem is provided by a header for a pouch comprising at least two compartments separated by a seal, the header comprising a device from which the said pouch can hang whereby in use at least one of the said compartments hangs to one side of the device and at least another one of the said compartments hangs on an opposing side of the device.

**Fig.1.**

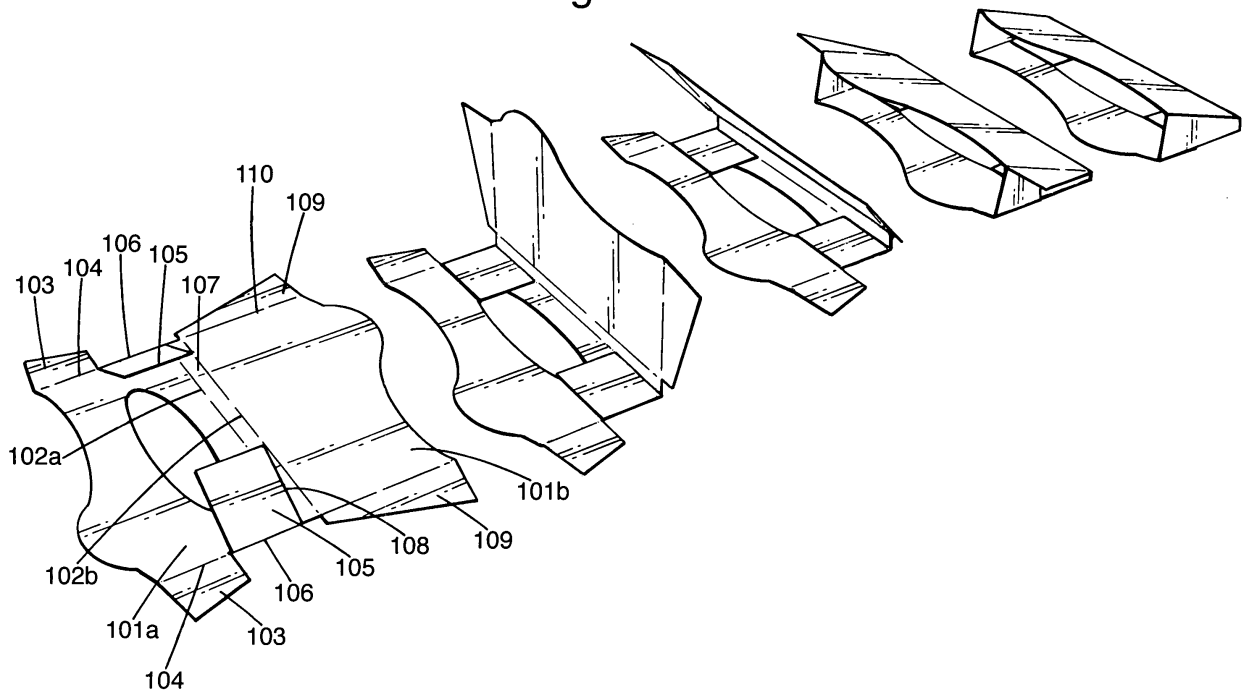

## Description

**[0001]** This invention relates to a header for a pouch-type bag, in particular, for a multicompartment pouch-type bag, and a consumer article comprising a header and a multicompartment pouch-type bag.

**[0002]** The use of headers is well established in the retail industry as stiffeners, for providing advertising board for products to which the headers are attached and also to providing means for enabling display of the attached products by, for example, hanging from a suitable display rail. Where the product is bagged, attachment of the header to the bag is typically accomplished through the use of, for example, adhesive, staples or ultrasonic sealing.

**[0003]** Particular problems present themselves when a header is attached to a bag comprising a chilled or frozen food article. For example if the header is glued to the bag, the joint may weaken under humid conditions through hydrolysis of the adhesive bond. Furthermore the temperature at which the gluing step during packaging takes place must be carefully considered to minimise stresses on the adhesive joint caused by a combination of any mismatched coefficients of expansion of the header, bag and adhesive material and temperature fluctuations which may lead to joint rupture. As for the use of staples, this is not considered safe in food packaging. Ultrasonic sealing is very expensive being about ten times more expensive than conventional thermal sealing.

**[0004]** In the pre-prepared meals sector of the food industry, it is sometimes advantageous to package the various components of a pre-prepared meal separately. Examples include: vegetables with a pre-prepared sauce added when cooking the vegetables; and pasteurised dehydrated egg and water, again, added on cooking the egg. In each of the two aforementioned examples, the pre-prepared meal is packaged in a bag comprising two separate compartments.

**[0005]** Thus the invention provides a solution to the problems associated with attaching a header to a bag comprising a food article and, in particular, to a bag comprising more than one compartment.

## BRIEF DESCRIPTION

**[0006]** In a first aspect of the invention, a header for a pouch comprising at least two compartments separated by a seal is provided, the header comprising a device from which the said pouch can hang whereby in use at least one of the said compartments hangs to one side of the device and at least another one of the said compartments hangs on an opposing side of the device. A particular advantage of this arrangement of header is that attachment to a bag is through a means which is both non-permanent, and hence flexible, and does not in any way interfere with the bag which would risk, for example, puncturing or tearing the bag, thereby leaving the bag intact.

**[0007]** In particular, the device comprises an upper edge of at least one flap whereby in use at least one of the said compartments hangs adjacent one side of the flap and at least another one of the said compartments hangs adjacent an opposing side of the flap.

**[0008]** The header may additionally comprise opposing first and second side walls and a crease line separating the said side walls wherein the upper edge of the at least one flap is congruent with the crease line when the header is assembled. A particular advantage of this arrangement is that when assembled and in combination with a bag, the seal is sandwiched firmly between the upper edge of the at least one flap and the crease line reducing any slippage of the bag with respect to the header.

**[0009]** Preferably the device comprises the upper edge of two flaps.

**[0010]** For simplicity of construction the header is desirably unitary, that is to say, is constructed from a single piece.

**[0011]** In a further aspect of the invention, the header additionally comprises a means for arranging at least one of the compartments above at least another one of the compartments whereby in use to permit any contents of the at least one upper compartment to fall into the at least one lower compartment thereby to mix with any contents of the at least one lower compartment when the seal is broken. An advantage of such an arrangement is that the contents of the at least two compartments can be combined together in-situ without recourse to a mixing vessel and furthermore without any risk of spillage. With respect to a food article, the now mixed food article can be heated in-situ by microwave or a conventional oven.

**[0012]** In particular the means for arranging at least one of the compartments above at least one of the compartments comprises a pivotable panel, the pivotable panel comprising attaching means for the at least one upper compartment, whereby in use the pivotable panel pivots about the at least one lower compartment thereby to arrange the at least one upper compartment above the at least one lower compartment. Preferably the attaching means comprises the at least one flap.

**[0013]** The header may further comprise opposing first and second side walls and an opposing pair of intermediate walls for arranging the opposing first and second side walls in spaced relationship wherein the pair of intermediate walls are adjustable thereby to vary the distance between the opposing first and second side walls within a defined range. An advantage of this technical feature is that any one assembled header can accommodate a range of bag sizes within a defined range thus reducing the stock range size. Preferably each intermediate wall comprises a pair of overlapping side wall flaps.

**[0014]** A header may additionally comprise at least two side wall flaps and bottom wall flap thereby to form a box-like header with the opposing first and second side walls. An advantage of this arrangement is that the header is inherently self-standing and fully protects the pouch from,

for example, tampering.

**[0015]** In a still further aspect of the invention, a consumer article is provided including a pouch comprising at least two compartments separated by a seal and a header as set forth hereinabove. Preferably the pouch comprises two compartments.

**[0016]** The pouch preferably comprises a food article, more preferably a food article which is frozen or chilled to below room temperature.

#### BRIEF DESCRIPTION OF THE DRAWINGS

**[0017]** The invention is illustrated with reference to the following figures in which:

Figure 1 shows construction of a first embodiment of the inventive header in a sequence of steps;

Figure 2 shows construction of a second embodiment of the inventive header in a sequence of steps;

Figure 3 shows construction of a third embodiment of the inventive header in a sequence of steps; and

Figure 4 shows use of a fourth embodiment of the inventive header for arranging a first compartment above a second compartment in a sequence of steps thereby to mix the contents of both compartments in-situ.

Figure 5 shows construction of a fifth embodiment of the inventive header in a sequence of steps thereby to form a header box.

#### DETAILED DESCRIPTION

**[0018]** Figure 1 shows a first embodiment of header constructed from a single unitary piece of cardboard comprising first and second side walls (101a, 101b) defined by first and second parallel crease lines (102a and 102b) respectively, and a top wall (107) defined by both first and second parallel crease lines (102a and 102b). The first side wall (101a) is flanked by an opposing pair of first side wall flaps (103) each linked to the first side wall (101a) by first side wall flap crease lines (104). In addition the first side wall (101a) is flanked by an opposing pair of side flaps (105) each linked to the first side wall (101a) by side flap crease lines (106). The side flaps (105) are proximal to the first parallel crease line (102a) as the first side wall flaps (103) are distal from it such that the upper edge of each side flap (108) is a continuation of the first parallel crease line (102a). The second side wall (101b) is flanked by an opposing pair of second side wall flaps (109) each linked to the second side wall (101b) by second side wall flap crease lines (110).

**[0019]** In use with a bag comprising two compartments separated by a seal, the seal is placed on and in alignment with the first parallel crease line (102a) and the

opposing pair of side flaps (105) folded towards each other at side flap crease lines (106) so that they rest on a compartment. Then the second side wall (102b) is folded towards the pair of side flaps at the first and second parallel crease lines (102a and 102b). Finally the opposing pair of first side wall flaps (103) are folded towards each other at the first side wall flap crease lines (104) until they are approximately perpendicular to the first side wall (101a) and the opposing pair of second side wall flaps (109) are folded towards each other at the second side wall flap crease lines (110) until they meet the first side wall flaps (103) thereby to define the thickness of the assembled header. Attachment of the first and second side wall flaps is effected with adhesive.

**[0020]** A variant embodiment differs only in comprising a single side flap rather than a pair of opposing side flaps (105).

**[0021]** Figure 2 shows a second embodiment of header constructed from a single unitary piece of cardboard comprising first and second side walls (201a, 201b) defined by first and second parallel crease lines (202a and 202b) respectively, and a top wall (207) defined by both first and second parallel crease lines (202a and 202b). The first side wall (201a) is flanked by an opposing pair of first side wall flaps (203) each linked to the first side wall (201a) by first side wall flap crease lines (204). In addition the first side wall (201a) is joined at counter flap crease line (206), which is parallel to the first parallel crease line (202a), by a single counter flap (205). The counter flap crease line (206) is not continuous comprising two isolated counter flap crease lines adjacent the first side wall flaps (203) thereby defining a gap between the counter flap (205) and the first side wall (201a). The edge of the counter flap distal from the first parallel crease line (208) is defined such that when the counter flap (205) is folded towards the first side wall (201a), the edge (208) is congruent to the first parallel crease line (202a). The second side wall (201b) is flanked by an opposing pair of second side wall flaps (209) each linked to the second side wall (201b) by second side wall flap crease lines (210).

**[0022]** In use with a bag comprising two compartments separated by a seal, a first compartment is passed through the aforementioned gap until the seal can be placed on and in alignment with the first parallel crease line (202a). The counter flap (205) is then folded towards the first side wall (201a) at counter flap crease line (206) so that it rests on the first compartment. Then the second side wall (202b) is folded towards the counter flap at the first and second parallel crease lines (202a and 202b). Finally the opposing pair of first side wall flaps (203) are folded towards each other at the first side wall flap crease lines (204) until they are approximately perpendicular to the first side wall (201a) and the opposing pair of second side wall flaps (209) are folded towards each other at the second side wall flap crease lines (210) until they meet the first side wall flaps (203) thereby to define the thickness of the assembled header. Attachment of the first

and second side wall flaps is effected with adhesive.

**[0023]** Figure 3 shows a third embodiment of header constructed from a single unitary piece of cardboard comprising first and second side walls (301a, 301b) defined by first and second parallel crease lines (302a and 302b) respectively, and a top wall (307) defined by both first and second parallel crease lines (302a and 302b). The first side wall (301a) is flanked by an opposing pair of first side wall flaps (303) each linked to the first side wall (301a) by first side wall flap crease lines (304). In addition the first side wall (301a) is flanked by an opposing pair of side flaps (305) each linked to the first side wall (301a) by a pair of opposing side flap crease lines (306). The side flaps (305) are proximal to the first parallel crease line (302a) as the first side flaps (303) are distal from it such that the upper edge of each side flap (308) is a continuation of the first parallel crease line (302a). The second side wall (301b) is flanked by an opposing pair of second side wall flaps (309) each linked to the second side wall (301b) by second side wall flap crease lines (310).

**[0024]** A variant embodiment differs only in comprising a single side flap rather than a pair of opposing side flaps (305).

**[0025]** In use with a bag comprising two compartments separated by a seal, the seal is placed on and in alignment with the first parallel crease line (302a) and the opposing pair of side flaps (305) folded towards each other at the pair of opposing side flap crease lines (306) so that they rest on one of the compartments. The distance between the pair of opposing side flap crease lines defines the thickness of the compartment under the opposing pair of side flaps (305). Then the second side wall (302b) is folded towards the pair of side flaps at the first and second parallel crease lines (302a and 302b). Finally the opposing pair of first side wall flaps (303) are folded towards each other at the first side wall flap crease lines (304) until they are approximately perpendicular to the first side wall (301a) and the opposing pair of second side wall flaps (309) are folded towards each other at the second side wall flap crease lines (310) until they meet the first side wall flaps (303) thereby to define the thickness of the assembled header. Attachment of the first and second side wall flaps is effected with adhesive.

**[0026]** Figure 4 shows a fourth embodiment of header which is a variant of the first and third embodiments set forth hereinabove comprising a front perforated tear line (401) which is a continuation of the lower edge of each side flap (108 and 308) thereby dividing the first side wall (101a and 301a) into a pivotable panel (402) and a fixed panel (403). This embodiment is adapted for use with a bag comprising a seal with a weakened section susceptible to bursting on the application of over-pressure to one or other of the compartments.

**[0027]** In use with the header assembled, the front perforated tear line (401) is broken and the pivotable panel is rotated about the second parallel crease line (102b and 302b) by approximately 180 degrees thereby to re-

locate an upper compartment above the other lower compartment. The contents of the upper compartment can be disgorged into the lower compartment by over pressurising the upper compartment thereby bursting a weakened section of seal.

**[0028]** Figure 5 shows a fifth embodiment of header constructed from a single unitary piece of cardboard comprising first and second parallel crease lines (502a and 502b) in alignment with central crease line (502c), first parallel crease line (502a) and central crease line (502c) defining a first top wall (507a), second parallel crease line (502b) and central crease line (502c) defining a second top wall (507b), first and second top walls (507a and 507b) meeting at central crease line (502c) and first side wall (501a) meeting first top wall (507a) at first parallel crease line (502a), and second side wall (501b) meeting second top wall (507b) at second parallel crease line (502b). The first side wall (501a) is flanked by an opposing pair of first side wall flaps (503) each linked to the first side wall (501a) by first side wall flap crease lines (504). The second side wall (501b) is flanked by an opposing pair of second side wall flaps (509) each linked to the second side wall (501b) by second side wall flap crease lines (510). The first top wall (507a) is flanked by an opposing pair of first top wall flaps (505a) each linked to the first side wall (507a) by first top wall flap crease lines (506a). The second top wall (507b) is flanked by an opposing pair of second top wall flaps (505b) each linked to the second top wall (507a) by second top wall flap crease lines (506b). First bottom flap (511a) is connected to first side wall (501a) at first bottom flap crease line (512a) located parallel to first parallel crease line (502a). Second bottom flap (511b) is connected to second side wall (501b) at second bottom flap crease line (512b) located parallel to second parallel crease line (502b). First bottom flap (511a) is flanked on opposing sides by a pair of bottom side flaps (513) which are connected to first side wall flaps (503) at a pair of bottom side flap crease lines (514).

**[0029]** In use with a bag comprising two compartments separated by a seal, the seal is placed on and in alignment with the central crease line (502c) and the opposing pair of second top wall flaps (505b) folded towards each other at second top wall flap crease lines (506b) so that they rest on a compartment. Then the second side wall (502b) is folded towards the pair of second top wall flaps (505b) at the first and second parallel crease lines (502a and 502b) and the central crease line (502c). The opposing pair of second side wall flaps (509) are folded towards each other at the second side wall flap crease lines (510) until they are approximately perpendicular to the second side wall (501b), and the opposing pair of first side wall flaps (503) are folded towards each other at the first side wall flap crease lines (504) and the opposing pair of first top wall flaps (505a) are likewise folded towards each other at the first top wall flap crease lines (506a) until they meet the second side wall flaps (509) thereby to define the thickness of the assembled header. Attach-

ment of the first and second side wall flaps (503, 509) and first top wall flaps (505a) is effected with adhesive.

**[0030]** Then the pair of bottom side flaps (513) are folded towards each other at a pair of bottom side flap crease lines (514) and first bottom flap (511a) folded towards the pair of bottom side flaps (513) at the first bottom flap crease line (512a) and attachment thereto effected with adhesive. Finally the second bottom flap (511b) is folded towards the first bottom flap (511a) at second bottom flap crease line (512b) and attachment thereto effected with adhesive thereby to form a box-like header.

### Claims

1. A header for a pouch comprising at least two compartments separated by a seal, the header comprising a device from which the said pouch can hang whereby in use at least one of the said compartments hangs to one side of the device and at least another one of the said compartments hangs on an opposing side of the device.
2. A header for a pouch comprising at least two compartments separated by a seal according to claim 1 wherein the device comprises an upper edge of at least one flap (108, 208 and 308) whereby in use at least one of the said compartments hangs adjacent one side of the flap and at least another one of the said compartments hangs adjacent an opposing side of the flap.
3. A header for a pouch comprising at least two compartments separated by a seal according to claim 2 wherein the header additionally comprises opposing first and second side walls (101a, 201a, 301a, 101b, 201b and 301b) and a crease line separating the said side walls wherein the upper edge of the at least one flap (108, 208 and 308) is congruent with the crease line when the header is assembled.
4. A header for a pouch comprising at least two compartments separated by a seal according to claim 2 or claim 3 wherein the device comprises the upper edge of two flaps (108 and 308).
5. A header for a pouch comprising at least two compartments separated by a seal according to any one of the preceding claims wherein the header is unitary.
6. A header for a pouch comprising at least two compartments separated by a seal in accordance with any one of the preceding claims wherein the header additionally comprising a means for arranging at least one of the compartments above at least another one of the compartments whereby in use to permit any contents of the at least one upper compartment to fall into the at least one lower compartment thereby to mix with any contents of the at least one lower compartment when the seal is broken.
7. A header for a pouch comprising at least two compartments separated by a seal according to claim 6 wherein the means for arranging at least one of the compartments above at least another one of the compartments comprises a pivotable panel (402), the pivotable panel (402) comprising attaching means for the at least one upper compartment, whereby in use the pivotable panel (402) pivots about the at least one lower compartment thereby to arrange the at least one upper compartment above the at least one lower compartment.
8. A header for a pouch comprising at least two compartments separated by a seal according to claim 7 wherein the attaching means comprises the at least one flap (108, 208 and 308).
9. A header for a pouch comprising at least two compartments separated by a seal according to any one of the preceding claims further comprising opposing first and second side walls (101a, 201a, 301a, 101b, 201b and 301b) and an opposing pair of intermediate walls for arranging the opposing first and second side walls (101a, 201a, 301a, 101b, 201b and 301b) in spaced relationship wherein the pair of intermediate walls are adjustable thereby to vary the distance between the opposing first and second side walls (101a, 201a, 301a, 101b, 201b and 301b) within a defined range.
10. A header for a pouch comprising at least two compartments separated by a seal according to claim 9 wherein each intermediate wall comprises a pair of overlapping side wall flaps (103, 203, 303, 109, 209 and 309).
11. A header for a pouch comprising at least two compartments separated by a seal according to any one of claims 3 to 10 additionally comprising at least two side wall flaps ( ) and bottom wall flap ( ) thereby to form a box-like header with the opposing first and second side walls (101a, 201a, 301a, 101b, 201b, 301b, 501a and 501b).
12. A consumer article including a pouch comprising at least two compartments separated by a seal and a header according to any one of the preceding claims.
13. A consumer article according to claim 12 wherein the pouch comprises two compartments.
14. A consumer article according to claim 12 or claim 13 wherein the pouch comprises a food article.

15. A consumer article according to claim 14 wherein the food article is frozen or chilled to below room temperature.

5

10

15

20

25

30

35

40

45

50

55

6

Fig.1.

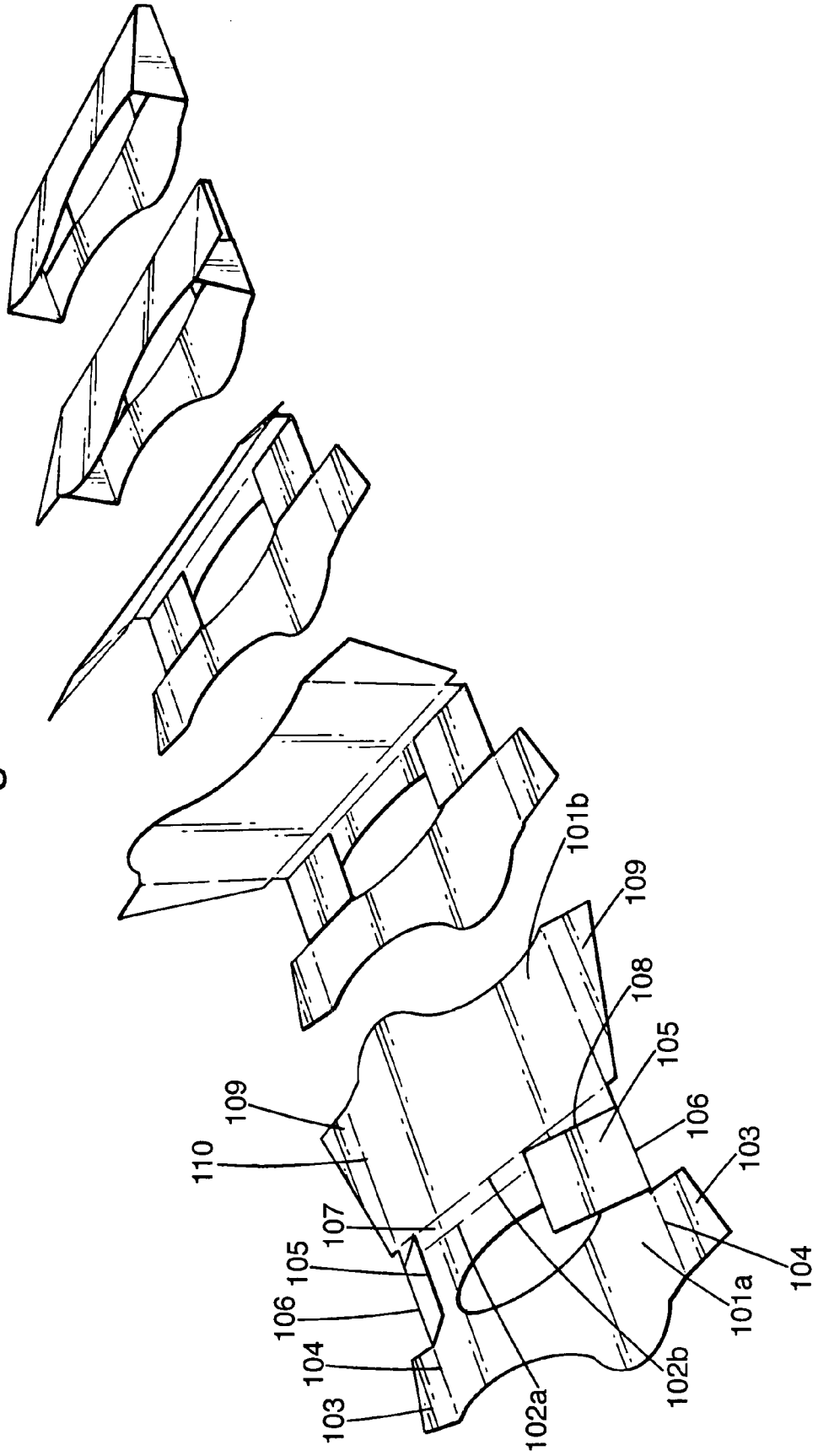

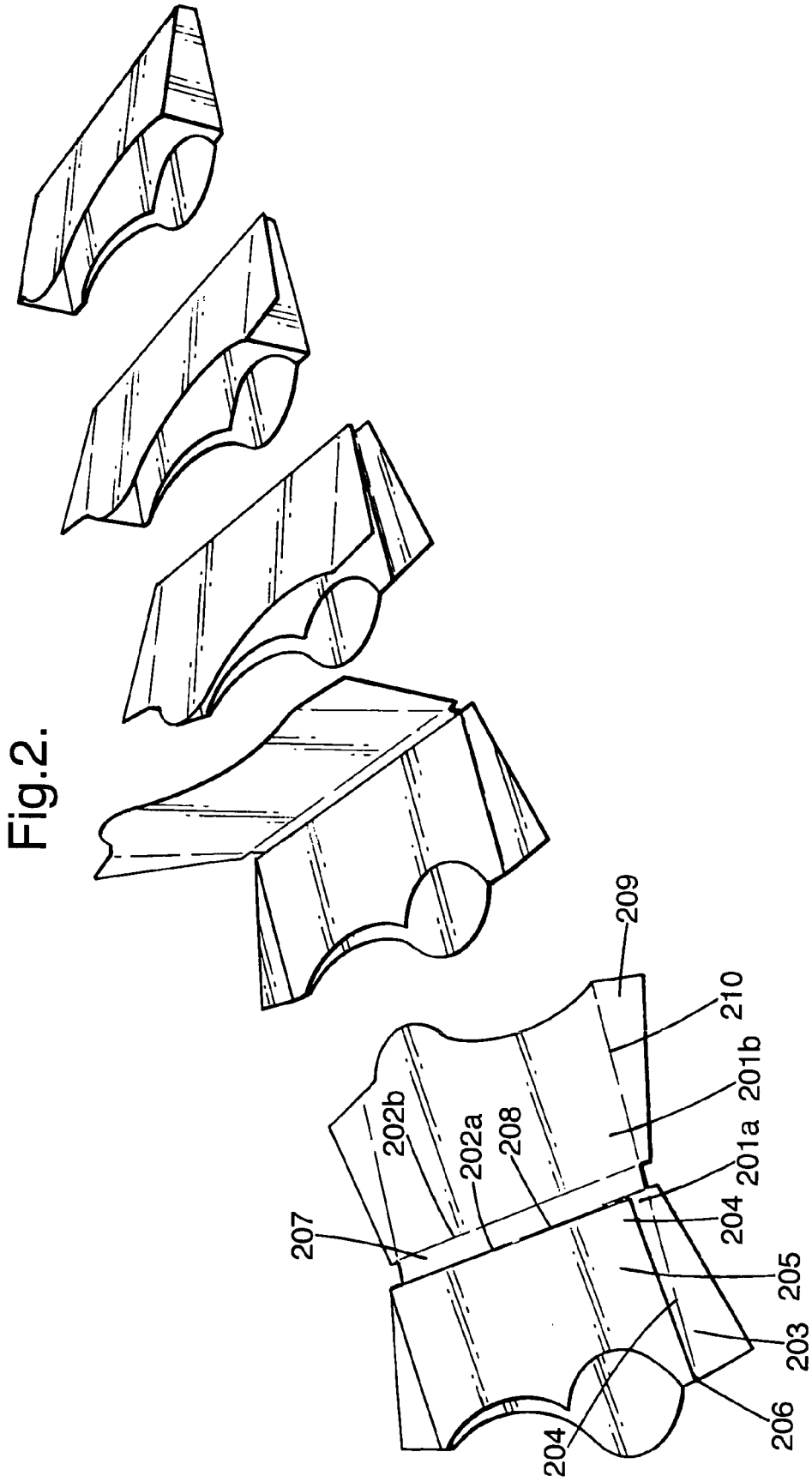

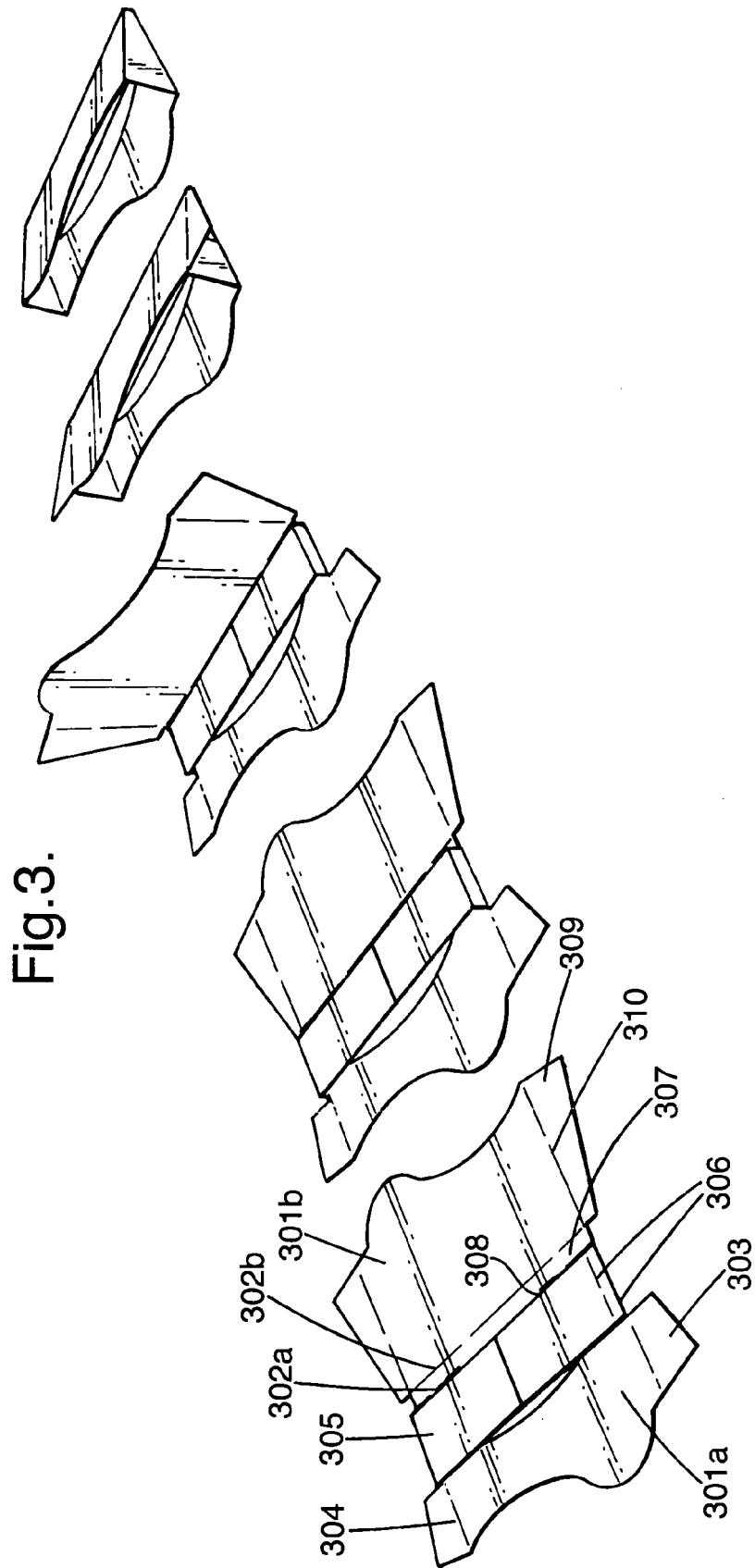

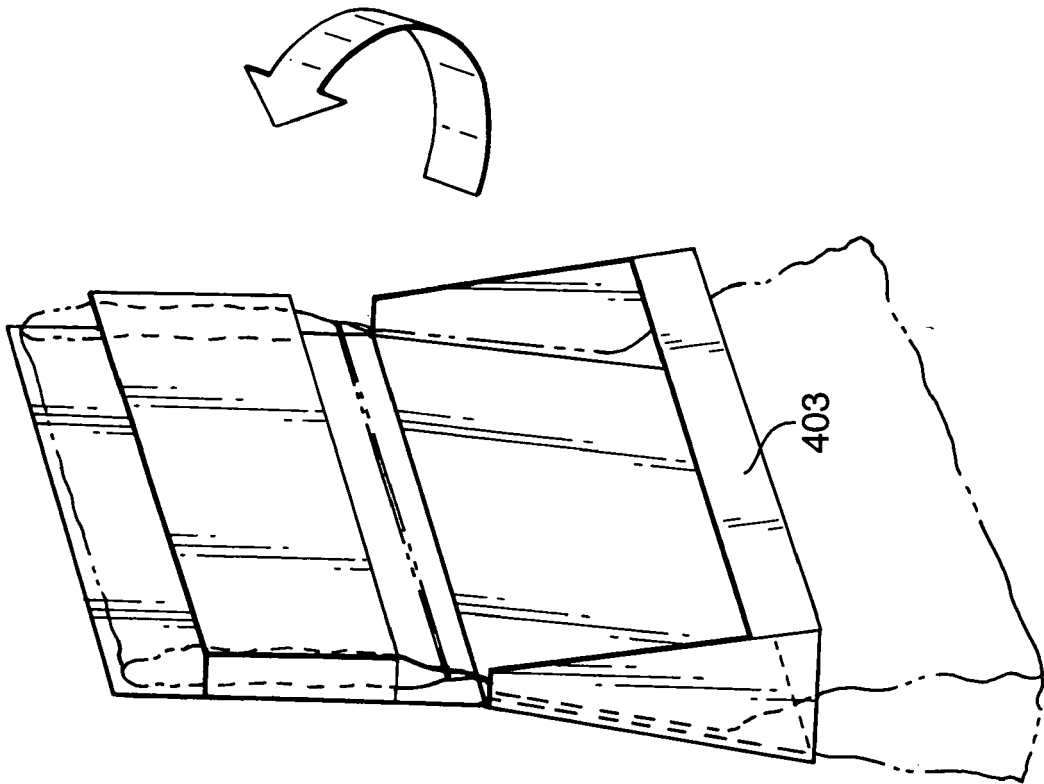

Fig.4.

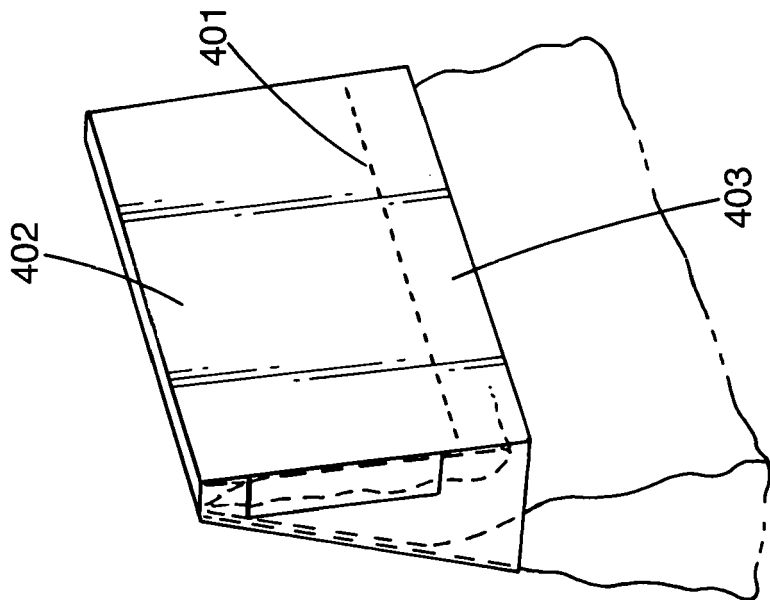
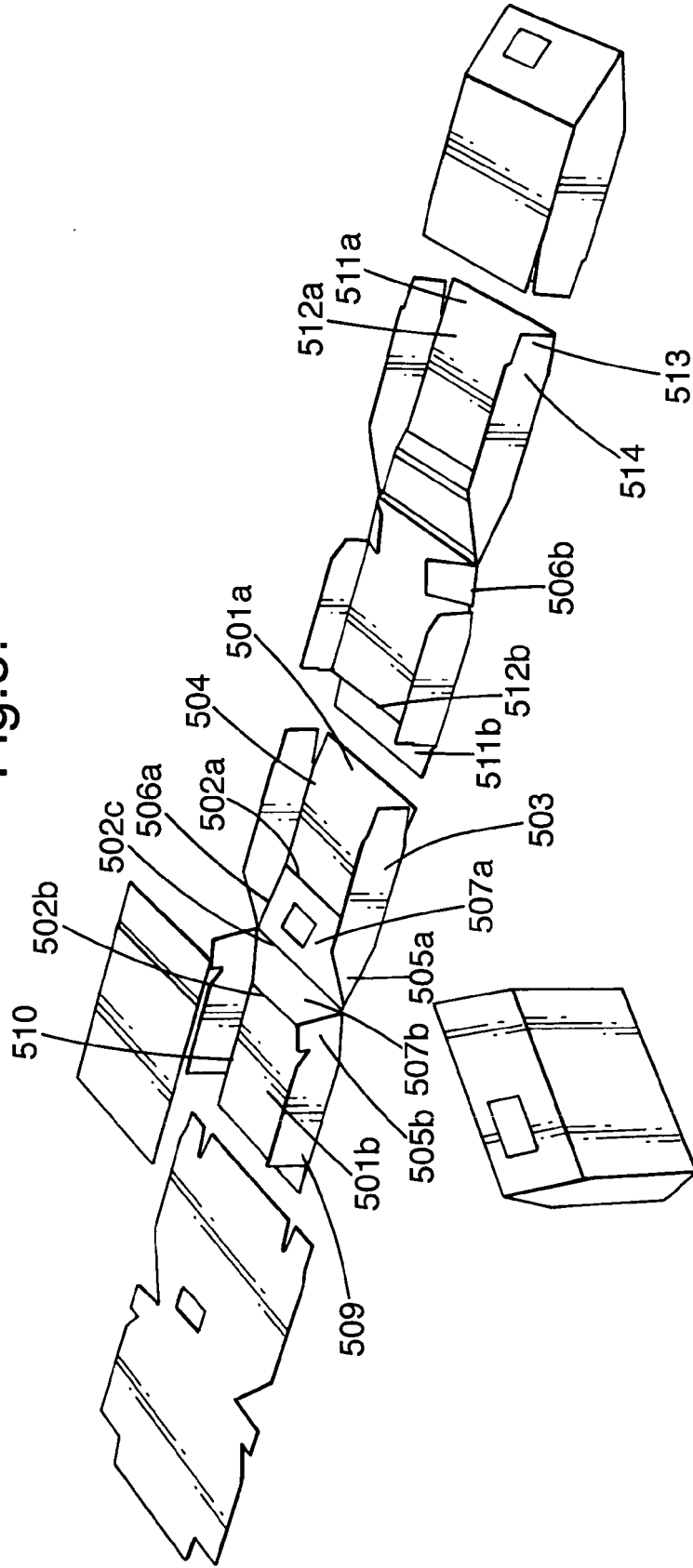

Fig.5.





DOCUMENTS CONSIDERED TO BE RELEVANT				
Category	Citation of document with indication, where appropriate, of relevant passages	Relevant to claim	CLASSIFICATION OF THE APPLICATION (IPC)	
X	DE 298 11 784 U1 (STARK ISTA GMBH, 71563 AFFALTERBACH, DE; HAGMANN, PETER, 74199 UNTERGR) 21 January 1999 (1999-01-21) * page 7, lines 10-28; figures 2,3 *	1	INV. B65D33/00	
X	US 2005/077375 A1 (TIMPSON DAVID) 14 April 2005 (2005-04-14) * paragraphs [0027], [0028]; figure 4 *	1		
X	US 4 305 503 A (MEMBRINO ET AL) 15 December 1981 (1981-12-15) * column 3, lines 58-68 - column 4, lines 1,2; figure 5 *	1,5, 12-14		
X	AU 752 955 B2 (UNCLE BEN'S, INC) 3 October 2002 (2002-10-03) * page 5, lines 20-27 - lines 1-7; figures 2,9-13 *	1		
A	US 3 285 497 A (STILLMAN NATHAN ET AL) 15 November 1966 (1966-11-15) * figures 1,2,5,6 *	1,12		TECHNICAL FIELDS SEARCHED (IPC)
A	US 4 560 068 A (MEMBRINO ET AL) 24 December 1985 (1985-12-24) * abstract; figures 1,2 *	1,12		B65D
A	EP 1 245 504 A (CRYOVAC, INC) 2 October 2002 (2002-10-02) * abstract; figure 3 *	1,12		
A	US 2001/047162 A1 (YUGARI YASUMI) 29 November 2001 (2001-11-29) * abstract; figure 1 *	1,12		
The present search report has been drawn up for all claims				
Place of search Munich		Date of completion of the search 16 May 2006	Examiner Visentin, M	
CATEGORY OF CITED DOCUMENTS X : particularly relevant if taken alone Y : particularly relevant if combined with another document of the same category A : technological background O : non-written disclosure P : intermediate document		T : theory or principle underlying the invention E : earlier patent document, but published on, or after the filing date D : document cited in the application L : document cited for other reasons ..... & : member of the same patent family, corresponding document		

4

EPO FORM 1503 03/82 (P04C01)

**ANNEX TO THE EUROPEAN SEARCH REPORT  
ON EUROPEAN PATENT APPLICATION NO.**

EP 05 25 7325

This annex lists the patent family members relating to the patent documents cited in the above-mentioned European search report. The members are as contained in the European Patent Office EDP file on The European Patent Office is in no way liable for these particulars which are merely given for the purpose of information.

16-05-2006

Patent document cited in search report		Publication date	Patent family member(s)	Publication date
DE 29811784	U1	21-01-1999	NONE	
-----				
US 2005077375	A1	14-04-2005	NONE	
-----				
US 4305503	A	15-12-1981	NONE	
-----				
AU 752955	B2	03-10-2002	AU 2873800 A	29-08-2000
			BR 0008163 A	22-01-2002
			CA 2362342 A1	17-08-2000
			EP 1189817 A1	27-03-2002
			JP 2002536261 T	29-10-2002
			MX PA01008168 A	23-10-2002
			NZ 513779 A	28-09-2001
			WO 0047484 A1	17-08-2000
			US 6153232 A	28-11-2000
			US 6395317 B1	28-05-2002
-----				
US 3285497	A	15-11-1966	NONE	
-----				
US 4560068	A	24-12-1985	CA 1234554 A1	29-03-1988
-----				
EP 1245504	A	02-10-2002	WO 02080623 A1	10-10-2002
-----				
US 2001047162	A1	29-11-2001	NONE	
-----				