

(19)



(11)

**EP 1 792 549 A2**

(12)

**EUROPEAN PATENT APPLICATION**

(43) Date of publication:  
**06.06.2007 Bulletin 2007/23**

(51) Int Cl.:  
**A45C 3/04 (2006.01) A45C 11/20 (2006.01)**  
**A45C 13/02 (2006.01) F25D 3/08 (2006.01)**

(21) Application number: **06011064.0**

(22) Date of filing: **30.05.2006**

(84) Designated Contracting States:  
**AT BE BG CH CY CZ DE DK EE ES FI FR GB GR HU IE IS IT LI LT LU LV MC NL PL PT RO SE SI SK TR**  
Designated Extension States:  
**AL BA HR MK YU**

(71) Applicant: **Berni Irio & C. S.N.C.**  
**42045 Luzzara RE (IT)**

(72) Inventor: **BERNI, Nicola**  
**42045 Luzzara (IT)**

(74) Representative: **Alagem Modiano, Lara S. et al**  
**Modiano & Associati**  
**Via Meravigli, 16**  
**20123 Milano (IT)**

(30) Priority: **02.12.2005 IT MI20050423 U**

**(54) Shopping bag made of flexible material having increased functionality**

(57) A shopping bag (1) made of flexible material having increased functionality, comprising a containment body (2) made of flexible material, which forms internally

an open region (10), a thermally insulated region (11), and a region (12) with partitions for accommodating bottles and the like.

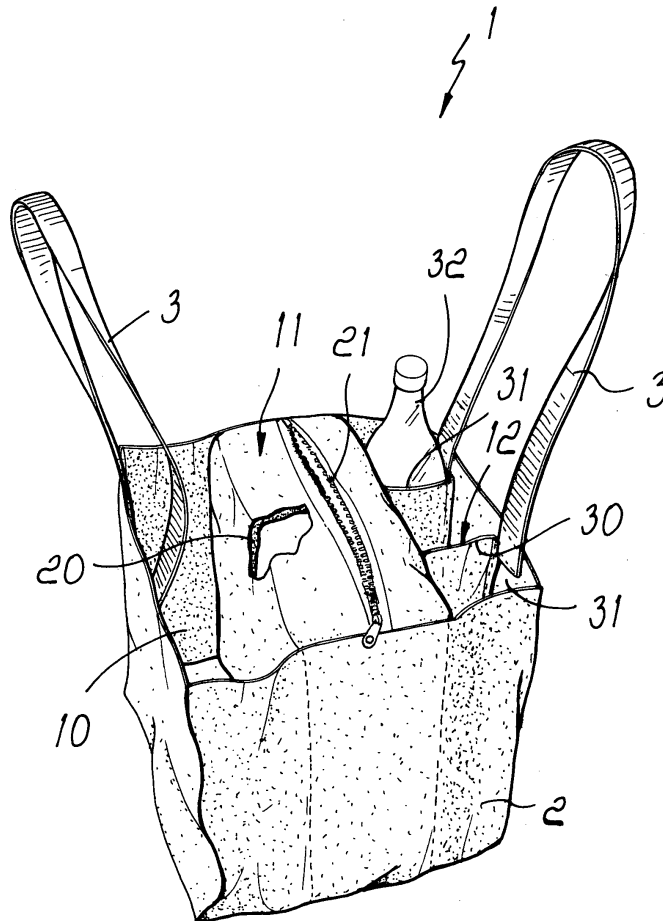

**EP 1 792 549 A2**

## Description

**[0001]** The present invention relates to a shopping bag made of flexible material having increased functionality.

**[0002]** As is known, several kinds of shopping bags are currently commercially available and are provided in the most disparate shapes and types.

**[0003]** Bags are also known which are dedicated specifically to a particular use, such as for example thermally-insulating bags for containing frozen or fresh products whose temperature must be maintained and bags provided with partitions for positioning bottles correctly.

**[0004]** Currently, these bags are all separate entities, which in many cases inconvenience the user, who encounters difficulties if he has to carry a number of separate bags.

**[0005]** The aim of the invention is to eliminate the drawbacks noted above by providing a shopping bag made of flexible material, having increased functionality, which allows to provide maximum efficiency of the functionality of the shopping bag by allowing to meet all typical requirements with a single element.

**[0006]** Within this aim, an object of the invention is to provide a shopping bag which causes no hindrance when not in use, since it can assume particularly compact dimensions.

**[0007]** Another object of the present invention is to provide a shopping bag which, thanks to its particular constructive features, is capable of giving the greatest assurances of reliability and safety in use.

**[0008]** Still another object of the present invention is to provide a shopping bag which can be easily obtained starting from commonly commercially available elements and materials and is also competitive from a merely economical standpoint.

**[0009]** This aim and these and other objects, which will become better apparent hereinafter, are achieved by a shopping bag made of flexible material having increased functionality, characterized in that it comprises a containment body made of flexible material, which forms internally an open region, a thermally insulated region, and a region with partitions for accommodating bottles and the like.

**[0010]** Further characteristics and advantages will become better apparent from the detailed description of a shopping bag made of flexible material having increased functionality, illustrated by way of non-limiting example in the accompanying drawings, wherein the only figure is a schematic partially cutout perspective view of the shopping bag.

**[0011]** With reference to the figure, the shopping bag made of flexible material having increased functionality according to the invention, generally designated by the reference numeral 1, comprises a containment body 2, which is advantageously made of fabric, plastic material or other sheet-like material which is sufficiently flexible and strong.

**[0012]** The containment body 2 forms, in an upward

region, an open region from which ribbon-like handles 3 extend, said handles being mutually opposite and allowing to support the bag by hanging it.

**[0013]** The bag 1 forms, within the body 2, an open region, designated by the reference numeral 10, which allows the insertion of loose products, as well as a thermally insulated region 11 and a region with partitions, which is designated by the reference numeral 12.

**[0014]** In greater detail, the region 11 is provided with a layer 20 of thermally insulating material and is provided with an opening which can be closed by means of a zip fastener 21 or optionally by way of other known means, such as for example a hook-and-loop tape of the type known commercially by the registered trademark Velcro.

**[0015]** Inside the body 2 there is also the region 12, which is provided by means of portions made of flexible material, designated by the reference numeral 30, which form a plurality of cells or compartments 31 in which it is possible to easily insert bottles 32.

**[0016]** In the illustrated example, the thermally insulated region is located centrally and the other two regions are arranged on either side; the arrangement may of course be changed in any manner according to the contingent requirements, and likewise all the constructive details and dimensions may be modified, without altering the concept that the solution idea consists in providing a shopping bag which allows to combine multiple distinct functionalities.

**[0017]** From what has been described above, it is therefore evident that the invention achieves the proposed aim and objects and in particular the fact is stressed that a shopping bag is provided which allows to combine in a single entity an open region for containing loose products, a thermally insulated region and a region with partitions for accommodating bottles and the like.

**[0018]** In practice, the materials used, as well as the contingent shapes and dimensions, may be changed according to requirements.

**[0019]** The disclosures in Italian Utility Model Application No. MI2005U000423 from which this application claims priority are incorporated herein by reference.

**[0020]** Where technical features mentioned in any claim are followed by reference signs, those reference signs have been included for the sole purpose of increasing the intelligibility of the claims and accordingly, such reference signs do not have any limiting effect on the interpretation of each element identified by way of example by such reference signs.

## Claims

1. A shopping bag made of flexible material, having increased functionality, **characterized in that** it comprises a containment body made of flexible material, which forms internally an open region, a thermally insulated region, and a region with partitions for accommodating bottles and the like.

2. The shopping bag according to claim 1, **characterized in that** said containment body is provided with ribbon-like handles arranged on mutually opposite edges.  
5
3. The shopping bag according to the preceding claims, **characterized in that** said thermally insulated region is provided by means of a layer of thermally insulating material.  
10
4. The shopping bag according to one or more of the preceding claims, **characterized in that** said thermally insulated region comprises an opening with closure means.  
15
5. The shopping bag according to one or more of the preceding claims, **characterized in that** said closure means comprise a zip fastener.
6. The shopping bag according to one or more of the preceding claims, **characterized in that** said closure means have hook-and-loop tapes.  
20
7. The shopping bag according to one or more of the preceding claims, **characterized in that** said region with partitions for accommodating bottles and the like is provided by means of sheet-like elements which form a plurality of cells or compartments.  
25
8. The shopping bag according to one or more of the preceding claims, **characterized in that** said thermally insulated region is arranged between said region with partitions and said open region.  
30
9. The shopping bag according to one or more of the preceding claims, **characterized in that** said ribbon-like handles engage respectively an upper edge of said open region and of said region with partitions.  
35

40

45

50

55

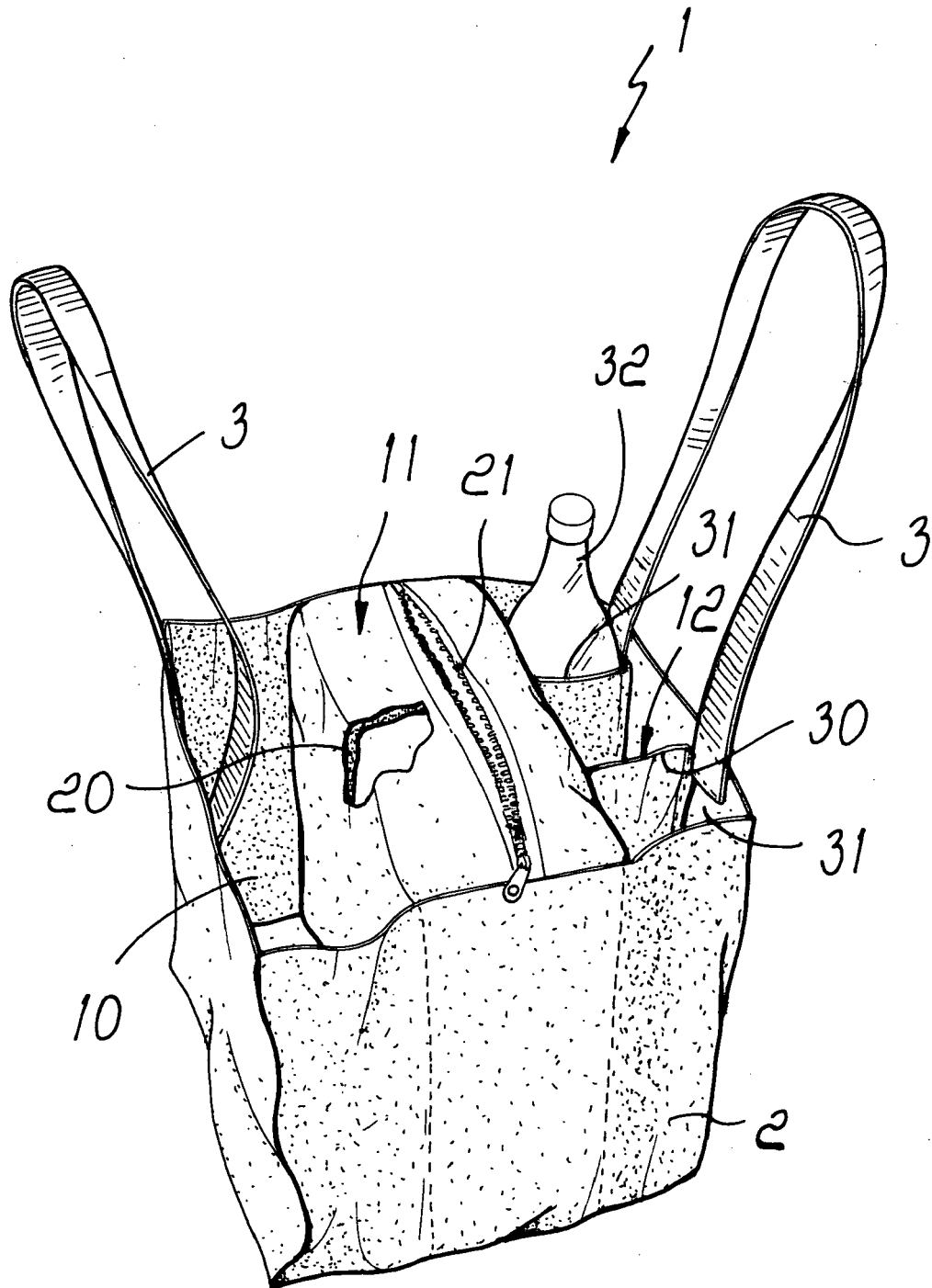

**REFERENCES CITED IN THE DESCRIPTION**

*This list of references cited by the applicant is for the reader's convenience only. It does not form part of the European patent document. Even though great care has been taken in compiling the references, errors or omissions cannot be excluded and the EPO disclaims all liability in this regard.*

**Patent documents cited in the description**

- IT MI20050423 U [0019]