

(19)



(11)

**EP 1 795 453 A1**

(12)

**EUROPEAN PATENT APPLICATION**  
published in accordance with Art. 158(3) EPC

(43) Date of publication:  
**13.06.2007 Bulletin 2007/24**

(51) Int Cl.:  
**B65D 23/10 (2006.01)**

(21) Application number: **04766968.4**

(86) International application number:  
**PCT/ES2004/000430**

(22) Date of filing: **01.10.2004**

(87) International publication number:  
**WO 2006/048469 (11.05.2006 Gazette 2006/19)**

(84) Designated Contracting States:  
**ES FR PT**

(72) Inventor: **BERNAL ARDANAZ, Javier**  
**E-20305 Irun (Guipuzcoa) (ES)**

(71) Applicant: **Betapack S.A.**  
**20305 Irun (Guipuzcoa) (ES)**

(74) Representative: **Carpintero Lopez, Francisco et al**  
**Herrero & Asociados, S.L.**  
**Alcalá 35**  
**28014 Madrid (ES)**

(54) **HANDLE FOR BOTTLES**

(57) The present invention relates to a handle for transporting bottles of the type which are coupled to the bottle's neck by a ring provided with a series of inner retaining flanges. One of the objectives of the invention

is that the handle can be coupled to the bottle's neck during the production process without damaging the previously mounted cap. Another objective is that each flange has resistance adapted to the load stresses it has to withstand according to its location.

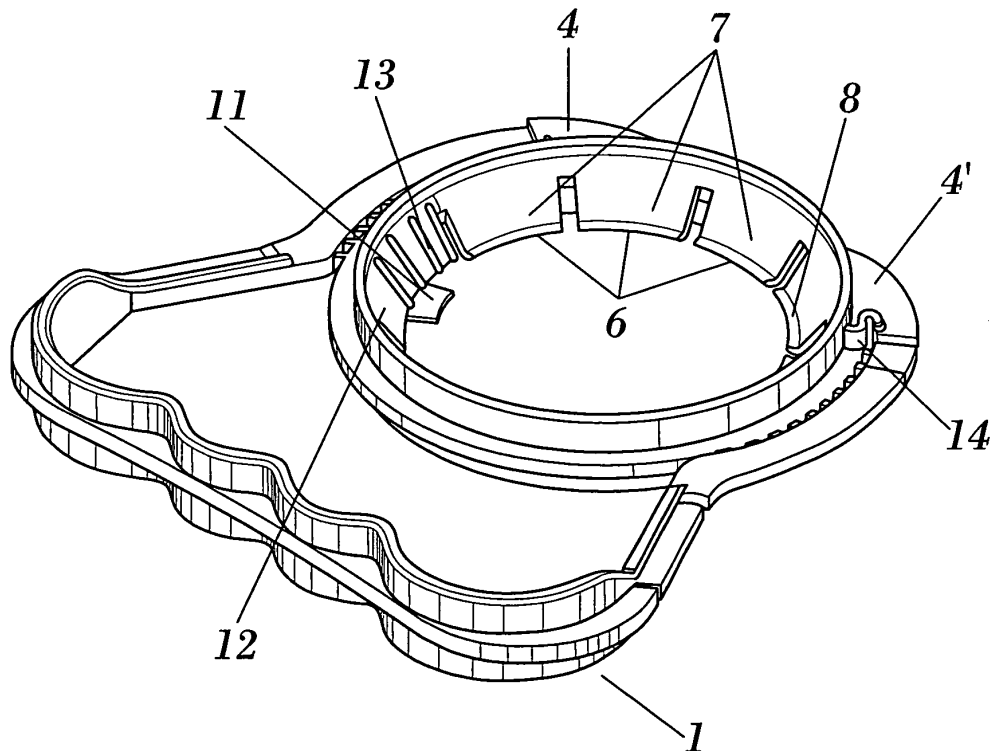

**FIG. 2**

**EP 1 795 453 A1**

**Description****OBJECT OF THE INVENTION**

[0001] The present invention relates to a handle, of the type of the designed to be coupled to the neck of a bottle to enable the manual transporting thereof and, in particular, of the type that consist of a ring which is coupled to the bottle's neck and whereto is fixed a series of flanges and from whose ring the handle emerges laterally and horizontally, which, at the time of use, tilts by the weight of the bottle towards a position of verticality.

[0002] An object of the invention is the distribution, resistance and design of the fixing flanges so that they have the resistance and flexibility required in accordance with their area of action, both in loading and in the phase of coupling to the bottle, to efficiently withstand the load distribution, which is not uniform, as well as so that at the time of coupling the handle to the bottle the flanges give the right amount, so that the cap which had previously been mounted to the bottle is not damaged.

**BACKGROUND OF THE INVENTION**

[0003] Handles are known to facilitate the handling and transport of large capacity bottles (generally from 3 to 5 litres), which consist of a U-shaped handgrip, which has a central part for the user's hand to grip, and two side branches whereby it is joined to a coupling ring to the bottle's neck, whose ring has a series of uniform internal flanges for the fixing of the handle to the bottle's neck.

[0004] In the evolution of this type of handle it has been anticipated that the articulation points of the handle to the ring, which were initially centred, are displaced to a rear area, which produces, on the one hand, greater facility for the articulation of the handle by the bottle's own weight and, on the other hand, a markedly larger space for the introduction of the hand, making the handling and transport of the bottle more comfortable.

[0005] A handle of this type is disclosed, for example, in application PCT WO 03/062071 by the same holder. In this patent is it is further observed that side branches are fixed to the ring, in a large sector, by an easy to tear membrane, to ensure that the handle-ring assembly is maintained perfectly flat during the handling manoeuvres necessary for its mounting on the bottleneck.

[0006] The displacement of the articulation point of the handle with respect to the ring towards the rear area thereof, means that the distribution of the weight of the bottle on the different flanges is not uniform, i.e. the flanges are not subjected to the same stresses, so that the flanges close to the area of articulation withstand a lot of weight, whilst the opposite flanges withstand less weight.

[0007] An obvious solution would be to uniformly reinforce all the flanges of the ring, but this solution would give the result of excessively rigid flanges, with little flexibility, which may cause damages in the cap at the time of its coupling to the bottle, since the cap would have

been previously mounted, damages that may consist, for example, in the tearing of the tamper seal.

**DESCRIPTION OF THE INVENTION**

[0008] The handle object of the invention resolves the aforementioned problems, and, furthermore, is more ergonomic, lighter and with greater resistance than the handles known to date.

[0009] A handle is, therefore, offered which has sufficiently slight resistance at the time of its insertion in the bottle's neck, to not damage the already mounted cap and that, at the same time, each flange or group of flanges is capable of withstanding the stress its position in the ring requires in the maximum load position.

[0010] For this purpose, the invention provides a handle for bottles wherein the retaining flanges are not identical, but their form, position and number are determined in accordance with the distribution of stress that they must withstand, it being necessary that some of said flanges are more reinforced than others, some have a more pronounced and robust attack edge to the bottleneck than others and some flanges have a greater length and include reinforcing ribs.

[0011] Each flange or group of flanges is designed to act on a specific area of the ring, in order to optimize its efficiency at each point.

[0012] In particular, it has been provided that the front flanges, i.e. those where the articulation points of the handle are closest to the ring, are more reinforced than those of the other flanges, further incorporating a more pronounced attack edge on the bottleneck since the handle in this area tends to separate from the bottleneck.

[0013] The rear flanges, i.e. those which are in the area opposite the articulation of the handle, have less pronounced attack edges of the flange to avoid that, when the handle is introduced, the flanges may wear and damage the cap.

[0014] Furthermore, the attack edges of the rear flanges are more inclined with respect to the horizontal than in the front flanges, to further favour the introduction of the handle.

[0015] Two double flanges have also been provided, i.e. with a length double that of the others. These double flanges also have vertical reinforcing ribs which avoid that they can crack or twist, as a consequence of the stresses that the weight of the bottle causes in the area where these flanges are positioned.

[0016] It has also been anticipated that at least two of the flanges of the ring have flat pins, which are projected horizontally, which have the object of the handle being more clasped to the bottleneck and can withstand without moving or displacing, minimizing the movement of the handle on the bottle. This avoids problems in the palletization of the bottles and allows them to be arranged easily.

[0017] Finally, it has been provided that the radius of curvature of the flanges in their joining area to the ring is

not the same in all of them, having a more pronounced radius in some than in others.

**[0018]** A greater connecting radius means that the flexibility of the flange decreases and its resistance is greater, for which reason, in the areas closest to the tilt points of the handle, the radius of curvature is greater.

**[0019]** In particular, the front flanges will have a greater radius of curvature since they are areas where the handle withstands greater stresses, whilst the rear flanges have less radius of curvature since they withstand less stress and it is of interest that the flanges of this area are more flexible to favour the introduction of the ring in the bottle's neck.

### DESCRIPTION OF THE DRAWINGS

**[0020]** To complement the description being made and with the object of helping towards a better understanding of the characteristics of the invention, in accordance with a preferred example of practical embodiment thereof, a set of figures is attached as an integral part of the description, wherein the following has been represented with an illustrative non-limitative character:

- Figure 1.- shows a perspective view of the handle object of the invention, before its mounting on the bottle's neck.
- Figure 2.- shows a lower perspective view of the handle object of the invention, before its mounting on the bottle's neck.
- Figure 3.- shows an elevational and partially sectional view of the handle, before its mounting on the bottle's neck.
- Figure 4.- shows a sectional detail of one of the front flanges.
- Figure 5.- shows a sectioned detail of one of the rear flanges.

### PREFERRED EMBODIMENT OF THE INVENTION

**[0021]** As is observed in figure 1, the handle object of the invention is composed of a handgrip (1), which comprises a central branch (2) whereby the user grips the handle with his/her hand, as well as a pair of side arms (3,3') whereby it is joined to a ring (5) which can be coupled to the bottle's neck. As can be observed, the joining areas (4,4') between the handgrip (1) and the ring (5) are not centred with respect to a diameter thereof, but they are displaced towards the rear part of the ring (5) so that the handle can use bottles equipped with caps of a certain height, such as those called tap caps, there also remaining a free space so that the user grips the handle comfortably with his/her hand.

**[0022]** The ring (5) is provided on its inner surface with a series of flanges (6) which act against a perimeter rib provided on the bottle's neck in order to prevent the exit of the handle with respect to the bottle and resist the weight thereof whilst being transported by the user.

**[0023]** When the joining areas (4, 4') of the handgrip (1) are displaced with respect to the diameter of the bottle's neck, the distribution of stresses on the flanges (6) of the ring (5) is not uniform, but is greater in the areas close to the joining areas (4,4') between the handgrip (1) and the ring (5). In particular, the joining areas (4,4') are disposed on the part opposite the handgrip (11), an area which we will call front, whilst the area closest to the handgrip (11) is the area which we will call rear.

**[0024]** In accordance with the object of the invention the flanges (6) of the ring (5) have been redesigned, in accordance with the distribution of stress that they must withstand but, at the same time, making the ring have a minimum resistance in its introduction in the bottle's neck, to avoid damages in the cap, for example the coming off of the tamper seal.

**[0025]** In particular, five flanges have been provided in the joining area (4,4'), which we will call front flanges (7), which are more reinforced than the other flanges.

**[0026]** Furthermore, these front flanges (7) have protuberances or attack edges (8) which are more pronounced than the other flanges in order to correctly clasp the handle to the bottle's neck.

**[0027]** The ring incorporates in the area closest to the handgrip (1) two rear flanges (9) with more reduced attack edges (8) in order to avoid that when the handle is introduced in the bottleneck, it may wear and damage the cap.

**[0028]** As is observed in figure 5, the attack edge (8) of these rear flanges (9) is inclined with respect to the horizontal to further favour the introduction of the ring.

**[0029]** The incorporation of two double side flanges (10) each one of them disposed between the front flanges (7) and the rear flanges (9) have also been provided, having a size approximately double the other flanges. In this area, the distribution of the stresses normally causes one of the flanges to be disabled so that with the double side flange (12), the possible cracks that may appear do not cause its disablement.

**[0030]** These double side flanges (10) are equipped with reinforcing ribs (13), positioned longitudinally with respect to the flange, and which are designed to avoid their twisting and cracking.

**[0031]** Likewise, as has been clearly observed in figure 3, it has been provided that the radius of curvature of the flanges is not the same for all of them. Thus, for example, the front flanges (7), corresponding to the areas where the handle works more and which are, therefore, subjected to greater stresses, have a greater radius of curvature (R1) that reduces the flexibility of the flange and increases its resistance. The rear flanges (9), disposed in the area where the handle works less, have less radius of curvature (R2) to favour their flexibility and, therefore, the introduction of the ring.

The invention also provides that some of the flanges (6) have a tab (11) on their free edge and disposed substantially parallel to the plane of the ring (5), which has the function of claspings the ring (5) to the bottle's neck and

reducing the freedom of movement of the handle with respect to said neck and thus facilitating the palletization and arrangement of the containers during their transport. In this embodiment, it is each of the rear flanges (8) that has a tab (11).

5

## Claims

1. Handle for bottles which comprises a handgrip (1) joined to a ring (5) to couple it to the bottle's neck, which has on its inner surface a plurality of flanges (6), in inclined position, **characterized in that** the ring (5) contains flanges of different configuration, resistance and flexibility, such as front flanges (7), provided in proximity to the joining area (4,4') of the handgrip (1) to the ring (5), rear flanges (9), in the area opposite the joining area (4,4') and double side flanges (10), between the front (7) and rear (9) flanges.
 

10  
15  
20
2. Handle for bottles, according to claim 1, **characterized in that** the front flanges (7) are more reinforced than the other flanges and incorporate one attack edge (8) more pronounced than the others.
 

25
3. Handle for bottles, according to claim 1, **characterized in that** the front flanges (7) have a connecting radius (R1) to the ring (5), greater than the connecting radius (R2) whereby the rear flanges (9) are joined to said ring (5).
 

30
4. Handle for bottles, according to claim 1, **characterized in that** the double side flanges (10), preferably in a number of two, have a length approximately double the other flanges.
 

35
5. Handle for bottles, according to claim 4, **characterized in that** the double side flanges (10) are equipped with reinforcing ribs (13).
 

40
6. Handle for bottles, according to claim 1, **characterized in that** at least two flanges have a tab (11), on their free edge and disposed substantially parallel to the plane of the ring (5), which has the function of clasp-  
ing the ring (5) to the bottle's neck and reducing the freedom of movement of the handle with respect to said neck and thus facilitating the palletization and arrangement of the bottles during their transport.
 

45  
50

55

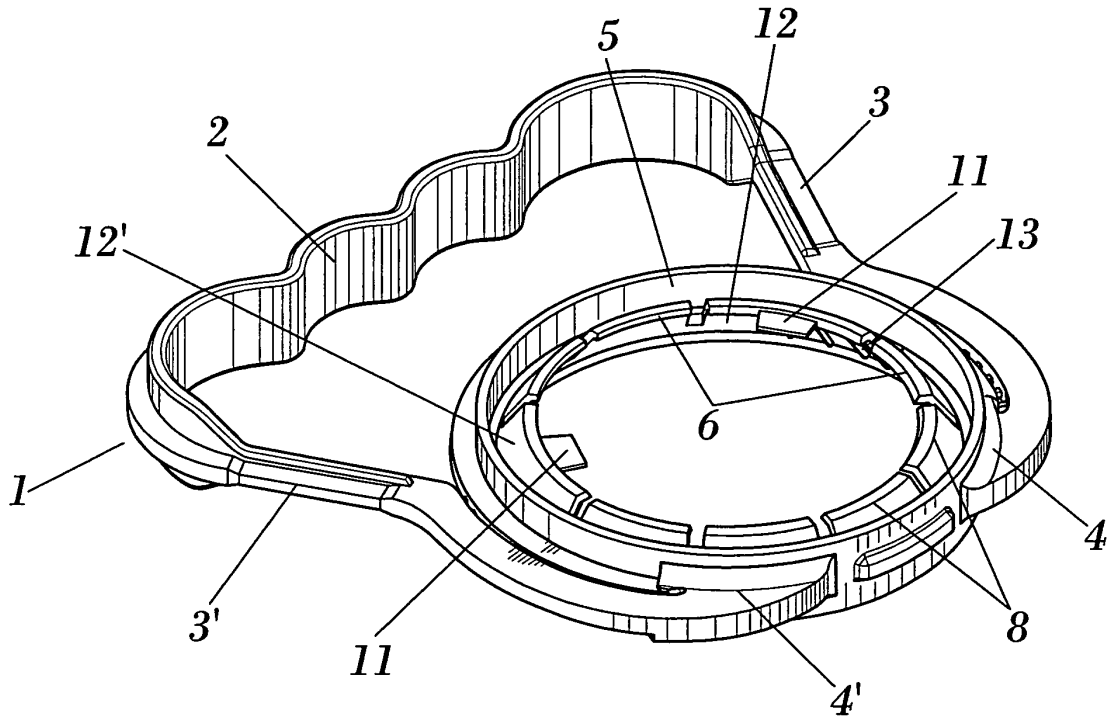

**FIG. 1**

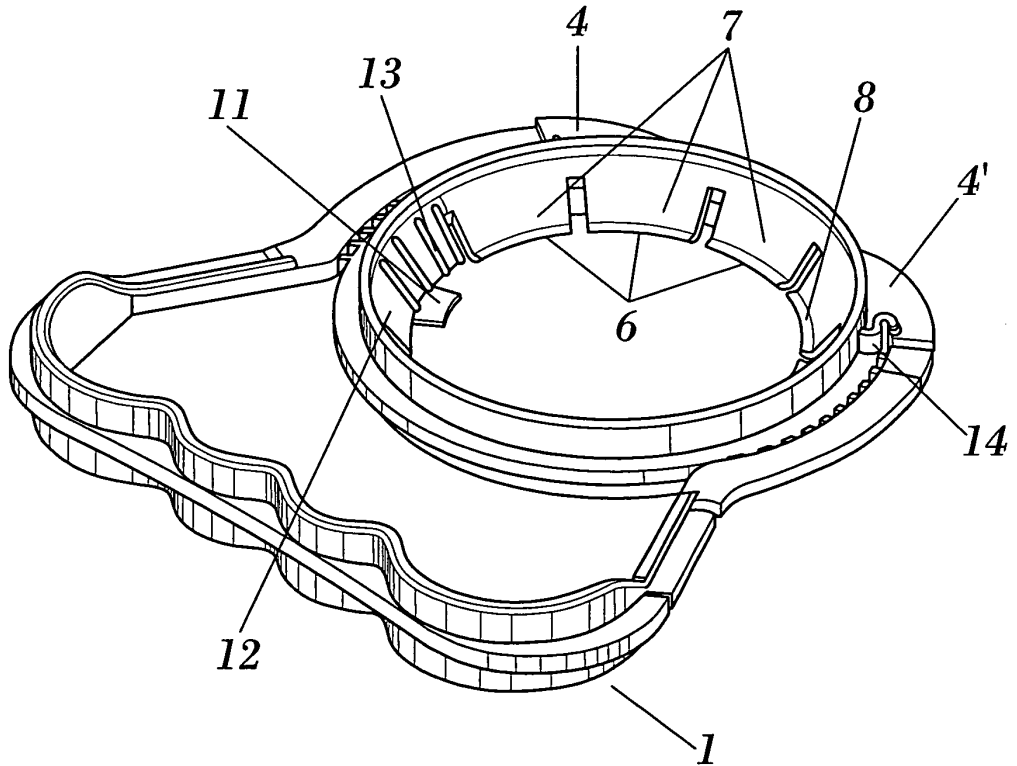

**FIG. 2**

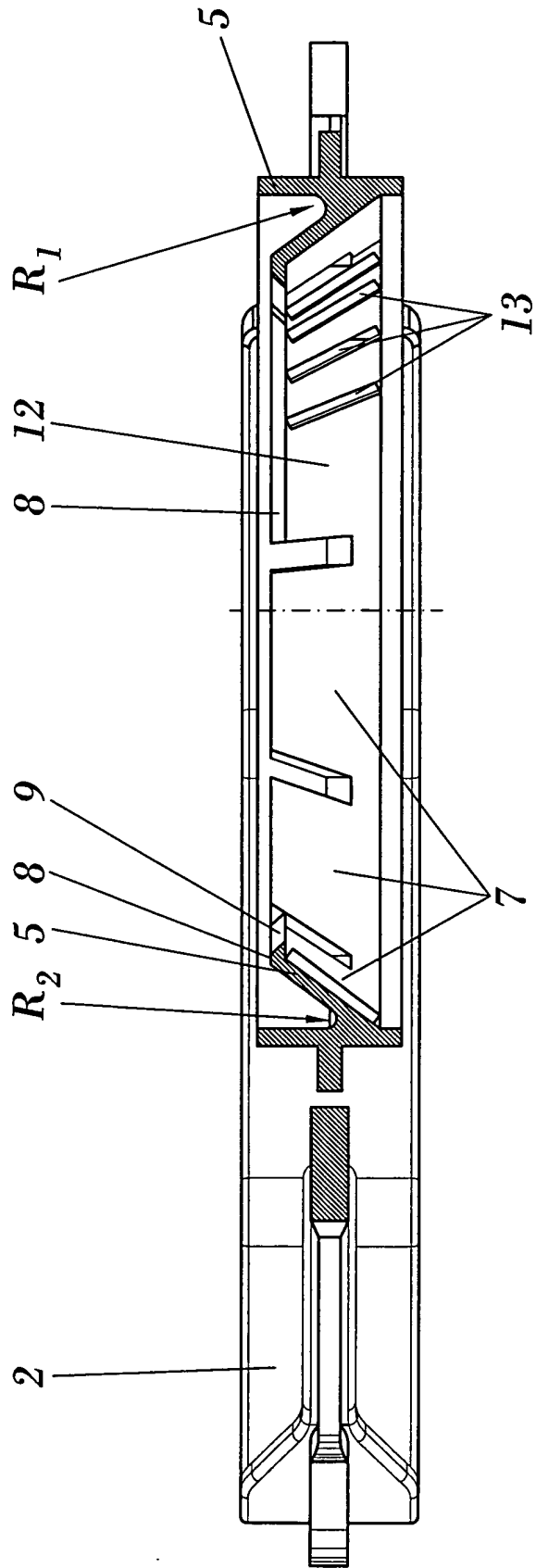

**FIG. 3**

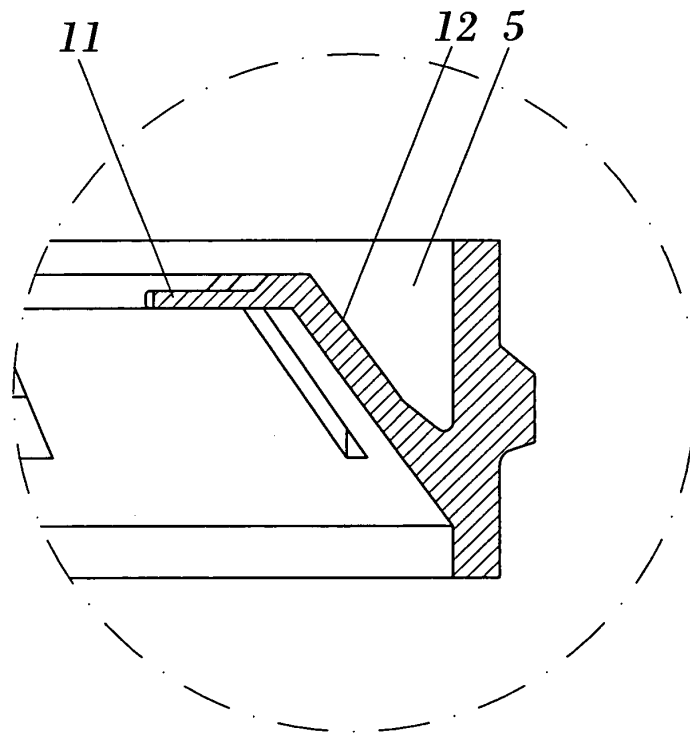

**FIG. 4**

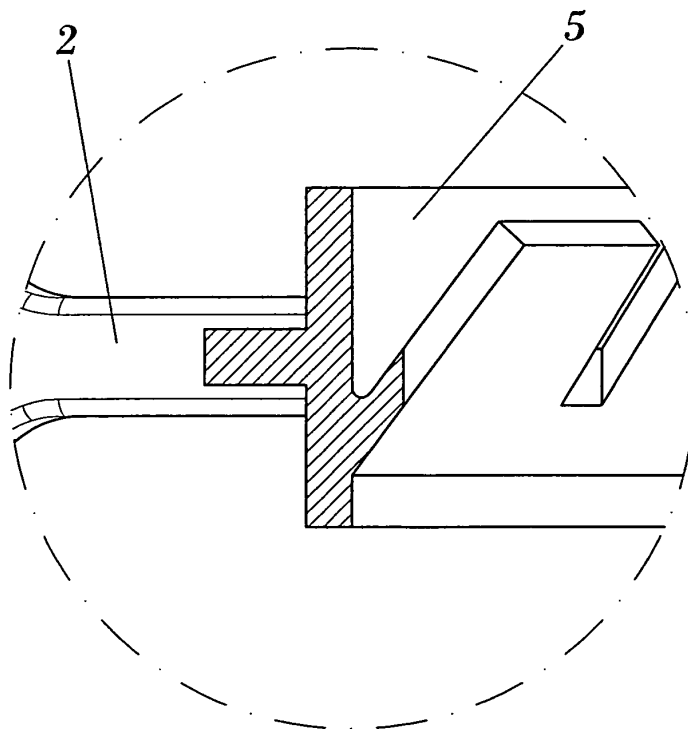

**FIG. 5**

## INTERNATIONAL SEARCH REPORT

International application No.

PCT/ ES 2004/000430

A. CLASSIFICATION OF SUBJECT MATTER <i>B65D 23/10 (2006.01)</i> According to International Patent Classification (IPC) or to both national classification and IPC		
B. FIELDS SEARCHED Minimum documentation searched (classification system followed by classification symbols) B65D Documentation searched other than minimum documentation to the extent that such documents are included in the fields searched Electronic data base consulted during the international search (name of data base and, where practicable, search terms used) CIBEPAT, EPODOC, WPI, PAJ		
C. DOCUMENTS CONSIDERED TO BE RELEVANT		
Category*	Citation of document, with indication, where appropriate, of the relevant passages	Relevant to claim No.
A	US 5735562 A (BORG) 07.04.1998, <b>the whole document</b>	1, 2
A	US 5480204 A (ERICKSON) 02.01.1996, column 2, line 62 - column 6, line 18; figures	1, 4
A	US 2004046406 A1 (BORG) 11.03.2004, page 1, line 12 - page 2, line 20; figures	1
A	US 3463536 A (UPDEGRAFF) 26.08.1969, column 3, lines 39-72; figures	1, 2, 4
A	US 5203481 A (DOBBINS) 20.04.1993, column 4, line 48 - column 5, line 4; figure 5	1
A	EP 0069334 A1 (RIEDEL DE HAEN A.G.) 12.01.1983, <b>abstract</b> : figures	1
<input type="checkbox"/> Further documents are listed in the continuation of Box C.		<input checked="" type="checkbox"/> See patent family annex.
* Special categories of cited documents: "A" document defining the general state of the art which is not considered to be of particular relevance "E" earlier document but published on or after the international filing date "L" document which may throw doubts on priority claim(s) or which is cited to establish the publication date of another citation or other special reason (as specified) "O" document referring to an oral disclosure, use, exhibition or other means "P" document published prior to the international filing date but later than the priority date claimed	"T" later document published after the international filing date or priority date and not in conflict with the application but cited to understand the principle or theory underlying the invention "X" document of particular relevance; the claimed invention cannot be considered novel or cannot be considered to involve an inventive step when the document is taken alone "Y" document of particular relevance; the claimed invention cannot be considered to involve an inventive step when the document is combined with one or more other such documents, such combination being obvious to a person skilled in the art "&" document member of the same patent family	
Date of the actual completion of the international search <b>19 January 2005 (19.01.2005)</b>	Date of mailing of the international search report <b>25 January 2005 (25.01.2005)</b>	
Name and mailing address of the ISA/ <b>SPTO</b>	Authorized officer	
Facsimile No.	Telephone No.	

Form PCT/ISA/210 (second sheet) (July 1992)

EP 1 795 453 A1

**INTERNATIONAL SEARCH REPORT**  
Information on patent family members

International Application No  
PCT/ ES 2004/000430

Patent document cited in search report	Publication date	Patent family member(s)	Publication date
US5735562 A	07.04.1998	<b>none</b>	-----
-----	-----	-----	-----
US5480204 A	02.01.1996	<b>none</b>	-----
-----	-----	-----	-----
US 2004046406 A	11.03.2004	US 6715810 B	06.04.2004
-----	-----	-----	-----
US3463536 A	26.08.1969	<b>none</b>	-----
-----	-----	-----	-----
US5203481 A	20.04.1993	<b>none</b>	-----
-----	-----	-----	-----
EP 0069334 A	12.01.1983	EP 19820105811 DE 3126483 A	30.06.1982 20.01.1983
-----	-----	-----	-----

**REFERENCES CITED IN THE DESCRIPTION**

*This list of references cited by the applicant is for the reader's convenience only. It does not form part of the European patent document. Even though great care has been taken in compiling the references, errors or omissions cannot be excluded and the EPO disclaims all liability in this regard.*

**Patent documents cited in the description**

- WO 03062071 A [0005]