



(11) **EP 1 796 091 B9**

(12) **CORRECTED EUROPEAN PATENT SPECIFICATION**

- (15) Correction information:  
**Corrected version no 1 (W1 B1)**  
**Corrections, see**  
**Claims EN 1, 4**
- (48) Corrigendum issued on:  
**12.06.2013 Bulletin 2013/24**
- (45) Date of publication and mention of the grant of the patent:  
**20.03.2013 Bulletin 2013/12**
- (21) Application number: **05783200.8**
- (22) Date of filing: **14.09.2005**
- (51) Int Cl.:  
**G11B 20/12 (2006.01) G11B 7/007 (2006.01)**  
**G11B 20/10 (2006.01)**
- (86) International application number:  
**PCT/JP2005/016911**
- (87) International publication number:  
**WO 2006/030813 (23.03.2006 Gazette 2006/12)**

(54) **INFORMATION RECORDING MEDIUM, INFORMATION RECORDING DEVICE AND METHOD, AND COMPUTER PROGRAM**

INFORMATIONSAUFZEICHNUNGSMEDIUM, INFORMATIONSAUFZEICHNUNGSEINRICHTUNG UND -VERFAHREN UND COMPUTERPROGRAMM

SUPPORT D'ENREGISTREMENT D'INFORMATIONS, DISPOSITIF ET PROCÉDE D'ENREGISTREMENT D'INFORMATIONS ET PROGRAMME INFORMATIQUE

- (84) Designated Contracting States:  
**AT BE BG CH CY CZ DE DK EE ES FI FR GB GR HU IE IS IT LI LT LU LV MC NL PL PT RO SE SI SK TR**
- (30) Priority: **17.09.2004 JP 2004271374**
- (43) Date of publication of application:  
**13.06.2007 Bulletin 2007/24**
- (73) Proprietor: **Pioneer Corporation**  
**Kanagawa 212-0031 (JP)**
- (72) Inventors:  
• **KATATA, Keiji;**  
**c/o PIONEER CORPORATION,**  
**Tokorozawa-shi, Saitama;3598522 (JP)**  
• **YOSHIDA, Masayoshi;**  
**c/o PIONEER CORPORATION,**  
**Tokorozawa-shi, Saitama;3598522 (JP)**
- **TANIKAWA, Toshiro;**  
**c/o PIONEER CORPORATION,**  
**Tokorozawa-shi, Saitama;3598522 (JP)**  
• **KURODA, Kazuo;**  
**c/o PIONEER CORPORATION,**  
**Tokorozawa-shi, Saitama;3598522 (JP)**
- (74) Representative: **Viering, Jentschura & Partner**  
**Am Brauhaus 8**  
**01099 Dresden (DE)**
- (56) References cited:  
**EP-A2- 1 204 106 WO-A2-2005/020232**  
**JP-A- 11 185 390 JP-A- 2001 023 170**  
**US-A1- 2004 156 294**
- **ECMA: STANDARDIZING INFORMATION AND COMMUNICATION SYSTEMS: "Standard ECMA-330:120 mm (4,7 Gbytes per side) and 80 mm (1,46 Gbytes per side) DVD Rewritable Disk (DVD-RAM)", STANDARD ECMA,, 1 June 2002 (2002-06-01), page 128, XP002310606,**

**EP 1 796 091 B9**

Note: Within nine months of the publication of the mention of the grant of the European patent in the European Patent Bulletin, any person may give notice to the European Patent Office of opposition to that patent, in accordance with the Implementing Regulations. Notice of opposition shall not be deemed to have been filed until the opposition fee has been paid. (Art. 99(1) European Patent Convention).

## Description

### Technical Field

**[0001]** The present invention relates to an information recording medium, such as a DVD, an information recording apparatus and method, such as a DVD recorder, and a computer program which makes a computer function as the information recording apparatus.

### Background Art

**[0002]** For example, in the information recording medium, such as an optical disc, like a CD-ROM (Compact Disc-Read Only Memory), a CD-R (Compact Disc-Recordable), a DVD-ROM and the like, there are developed a multi-layer type (i.e. a dual layer type optical disc, a multiple layer type, and so on), in which a plurality of recording layers are laminated on the same substrate. More specifically, such a dual layer type optical disc has a first recording layer (referred to as a "L0 layer" in this application), as the first layer, which is located on the front (i.e. a side closer to an optical pickup) as viewed from a laser light emission side in recording information by the information recording apparatus, and further has a semi-transparent reflective coating or film, located on the rear thereof (i.e. a side farther from the optical pickup). As the second recording layer, it has a second recording layer (referred to as a "L1 layer" in this application), located on the rear of the semitransparent reflective coating through a middle layer, such as an adhesive layer, and further has a reflective film located on the rear thereof. In preparing such a dual layer type information recording medium, the L0 layer and the L1 layer are individually formed and pasted in the end, to thereby prepare the two-layer type optical disc at a low cost.

**[0003]** In the information recording apparatus, such as a CD recorder and a DVD recorder, for recording information onto such a dual layer type optical disc, the record information is recorded into the L0 layer in a rewritable method or irreversible change recording method, such as irreversible change recording heating, by focusing the laser light for recording onto the L0 layer. The record information is recorded into the L1 layer in a rewritable method or irreversible change recording method, such as irreversible change recording heating, by focusing the laser light onto the L1 layer.

Patent document 1: Japanese Patent Application Laid Open NO. 2002-352469

**[0004]** US 2004/156294 A1 describes an optical information recording/reproducing information medium formed by laminating recording layers, and an information recording/reproducing method and an information recording/reproducing apparatus using the same. The recording/reproducing information medium (such as an optical disc) has a first to an n-th recording layers (n is

an integer of 2 or greater) laminated on a substrate, each of the first to the n-th layers having data regions segmented into a first to an m-th data zone groups (m is an integer of 2 or greater) along a radial direction of the optical disc, each of the first to the m-th data zone groups including at least one data zone.

### Disclosure of Invention

#### 10 Subject to be Solved by the Invention

**[0005]** In such a dual layer type optical disc, generally, at first, the data is recorded into the L0 layer. After the data is recorded in the entire L0 layer, the data is recorded into the L1 layer. Therefore, there arises such a situation that the data is recorded in the entire L0 layer, while the data is recorded only in one portion of the L1 layer. If a finalize process is performed in such a situation to reproduce the data on the optical disc on an existing CD-ROM player, an existing DVD-ROM player or the like, it is necessary to record dummy data in the L1 layer in which the data is not recorded. Thus, there is a technical problem that it takes more time to perform the finalize process, as compared to the size of the data actually recorded.

**[0006]** Thus, a recording method, which records the record information into the L0 layer and the L1 layer alternately (or in order to substantially uniform the data size of the record information recorded into each layer), may be conceived. Adopting such recording method, however, causes a need to store a point at which a recording object or target is changed from the L0 layer to the L1 layer or from the L1 layer to the L0 layer (i.e. a layer jump point), during the recording operation. In particular, if the finalizing is not performed yet, a disc drive or a host computer, which records the data by using the disc drive, or the like needs to store the layer jump point. Without storing the layer jump point, there arises a technical problem that it is difficult or impossible to read the data recorded on the optical disc.

**[0007]** Thus, for example, if the disc drive stores the layer jump point, it is necessary to rewrite recording management information for managing the recording of the data, every time the data is recorded. The recording management information, however, can be rewritten only about several hundred times on a DVD, which is one specific example of an optical disc, due to the restriction of the size of the recording area to record the recording management information therein. As a result, there is such a technical problem it is impossible to continue the recording of the record information if the layer jump is performed frequently.

**[0008]** On the other hand, if the host computer stores the layer jump point, it stores the layer jump point, generally on a memory provided for the host computer. However, if the optical disc is ejected, the layer jump point stored on the memory is also deleted. As a result, there is such a technical problem that it is impossible to record the data onto the optical disc or that it is impossible to

reproduce the data recorded on the optical disc.

**[0009]** It is therefore an object of the present invention to provide an information recording medium which enables the record information to be preferably recorded onto the information recording medium having a plurality of recording layers, for example, as well as an information recording apparatus and method, and a computer program which makes a computer function as the information recording apparatus.

**[0010]** Accordingly, the present invention provides an information recording medium, an information recording apparatus and an information recording method as featured in the independent claims 1, 4, and 8. Preferred embodiments of the present invention are described in the dependent claims 2 to 3, and 5 to 7.

### Means for Solving the Subject

#### (Information Recording Medium)

**[0011]** The above object of the present invention can be achieved by an information recording medium, provided with: a first recording layer and a second recording layer in which record information can be recorded; and a plurality of first block areas, each of which includes a recording area of a first size on the first recording layer and a recording area on the second recording layer located at a position facing the recording area of the first size on the first recording layer, and each of which is a unit by which the record information is recorded, at least one of the first recording layer and the second recording layer provided with a size area to record therein first size information which indicates the first size.

**[0012]** According to the information recording medium of the present invention, the record information can be recorded in each of the first recording layer and the second recording layer. The plurality of recording layers are formed in a lamination structure on one of the sides of a substrate, for example.

**[0013]** Particularly in the present invention, the record information is recorded into each of the first block area, which includes a recording area, having the first size, of a part of the first recording layer and a recording area of a part of the second recording layer. In particular, the recording area of a part of the first recording layer faces the recording area of a part of the second recording layer. The term "face" literally indicates the situation that the recording area of a part of the first recording layer faces the recording area of a part of the second recording layer. More specifically, it has a wide concept, including not only a case where the recording area of a part of the first recording layer strictly faces the recording area of a part of the second recording layer, namely, a case where that the former has an address with the same position relationship as the latter, but also a case where the former has an address which can be equated with that of the latter, and further including a relationship between the recording area of a part of the first recording layer and

the recording area of a part of the second recording layer in consideration of an eccentricity or the like, as described later. Then, the plurality of first block areas are included in the information recording medium. In other words, the record information is recorded by the unit of first block area. If the record information is further additionally recorded, following the once ended recording operation, the record information is recorded into a new first block area. Since the record information is recorded into each of the first block areas, as described above, the record information is less likely or hardly recorded with it distributed unevenly in either the first recording layer or the second recording layer. Thus, it is possible to reduce the size of an area or eliminate the area in which the dummy data needs to be recorded in a finalize process, as compared to an information recording medium on which the record information is recorded into the second recording layer after recorded in the entire first recording layer.

**[0014]** Moreover, the first size is recorded as the first size information into the size area on the information recording medium. Therefore, even if an information recording apparatus itself, discussed later, does not store a point at which the recording layer targeted for recording is changed, it is possible to recognize the plurality of first block areas, relatively easily. Namely, it is possible to preferably recognize a unit in which the first block area is changed and a point at which the recording layer targeted for recording is changed. Since the recording area of a part of the first recording layer constituting each of the first block areas has the same or substantially the same size, it is enough if the first size information is recorded once. In other words, it is unnecessary to record the first size information every time the recording layer targeted for recording is changed, which does not cause such a disadvantage that there is no more recording area in which the first size information can be recorded. Thus, it is possible to preferably continue the recording operation. Even if the information recording medium is ejected from an information recording apparatus before the finalize process, it is possible to preferably recognize a data structure on information recording medium (specially, the structures of the plurality of first block areas), by referring to the first size information recorded in the size area, especially even in the case where the record information is alternately recorded in respective recording layers. Therefore, on the basis of the recognized structure, it is possible to preferably continue the recording operation.

**[0015]** Consequently, according to the information recording medium of the present invention, it is possible to reduce a time length required for the finalize process, and it is also possible to preferably recognize a structure of how the record information is recorded, even if the record information is recorded into each recording layer. Thus, it is possible to preferably record the record information.

**[0016]** In one aspect of the information recording medium of the present invention, the recording area on the second recording layer located at the position facing the

recording area of the first size on the first recording layer has substantially the first size.

**[0017]** According to this aspect, the size of the recording area of a part of the second recording layer constituting the first block area is the same or substantially the same as the first size. In other words, the recording area of a part of the first recording layer and the recording area of a part of the second recording layer, which constitute the first block area, have the same or substantially the same size. Therefore, it is possible to substantially uniform the size of the record information recorded into the first recording layer and the size of the record information recorded into the second recording layer. Thus, it is possible to reduce the size of an area or eliminate the area in which the dummy data needs to be recorded in the finalize process.

**[0018]** In another aspect of the information recording medium of the present invention, it includes a plurality of second block areas, each of which includes a recording area of a second size, which is different from the first size, on the first recording layer and a recording area on the second recording layer located at a position facing the recording area of the second size on the first recording layer, and each of which is a unit by which the record information is recorded.

**[0019]** According to this aspect, even if the record information is not recorded into the first block areas, all of which have the same size, throughout the entire information recording medium, it is possible to record the record information into the second block areas, each of which is provided with a recording area having the second size, different from the first size which is the size of the recording area of a part of the first recording layer constituting the first block area. Therefore, it is possible to perform the recording operation, more flexibly, in accordance with features, such as the type and the size of the record information to be recorded.

**[0020]** Then, the second block area has the same structure as that of the first block area, so that it is possible to receive the above-mentioned various benefits.

**[0021]** In an aspect of the information recording medium including the second block areas, as described above, the recording area on the second recording layer located at the position facing the recording area of the second size on the first recording layer may have substantially the second size.

**[0022]** By virtue of such construction, the size of the recording area of a part of the second recording layer constituting the second block area is the same or substantially the same as the second size. In other words, the recording area of a part of the first recording layer and the recording area of a part of the second recording layer, which constitute the second block area, have the same or substantially the same size. Therefore, it is possible to substantially uniform the size of the record information recorded into the first recording layer and the size of the record information recorded into the second recording layer. Thus, it is possible to reduce the size of

an area or eliminate the area in which the dummy data needs to be recorded in the finalize process.

**[0023]** In an aspect of the information recording medium including the second block areas, as described above, second size information which indicates the second size may be further recorded into the size area.

**[0024]** By virtue of such construction, even in the second block area, the second size information is recorded, as in the first size information of the first block area. Therefore, it is possible to recognize the structure of the second block area, relatively easily and preferably, by referring to the second size information.

**[0025]** In another aspect of the information recording medium of the present invention, the size area is included in a recording management area into which recording management information for managing recording of the record information is recorded.

**[0026]** By virtue of such construction, the first size information (and furthermore, the second size information) is recorded into the size area included in the recording management area into which the recording management information for managing the recording of the record information is recorded. Thus, even in the middle of the recording operation, it is possible to preferably recognize a state on the information recording medium. As a result, it is possible to preferably record the record information.

(Information Recording Apparatus and Method)

**[0027]** The above object of the present invention can be also achieved by an information recording apparatus, provided with: a recording device for recording record information onto an information recording medium, provided with a first recording layer and a second recording layer in which the record information can be recorded; a first controlling device for controlling the recording device to record the record information by a unit of a first block area which includes a recording area of a first size on the first recording layer and a recording area on the second recording layer located at a position facing the recording area of the first size on the first recording layer; and a second controlling device for controlling the recording device to record first size information which indicates the first size, as the record information, into at least one of the first recording layer and the second recording layer.

**[0028]** According to the information recording apparatus of the present invention, by virtue of the operation of the recording device, it is possible to record the record information into the first recording layer and the second recording layer. Particularly in the present invention, by virtue of the operation of the first controlling device, the recording device is controlled to record the record information by the unit of the first block area which includes a recording area having the first size of a part of the first recording layer and a recording area of a part of the second recording layer. Thus, the record information is less likely or hardly recorded with it unevenly distributed in either the first recording layer or the second recording

layer. Thus, it is possible to reduce the size of an area or eliminate the area in which the dummy data needs to be recorded in the finalize process, as compared to an information recording medium on which the record information is recorded into the second recording layer after recorded in the entire first recording layer. By this, it is possible to reduce a time length required for the finalizing, which causes a great advantage that it is possible to improve the efficiency of the recording operation.

**[0029]** Moreover, since the record information is recorded into each of the first block areas, even if the additional recording of the record information is repeated, the record information is less likely or hardly recorded with it unevenly distributed in either the first recording layer or the second recording layer. Thus, even if the record information is recorded once or even if the record information is additionally recorded, it is possible to receive the above-mentioned various benefits.

**[0030]** Moreover, by virtue of the operation of the second controlling device, the first size is recorded as the first size information onto the information recording medium. Therefore, even if the information recording apparatus itself does not store a point at which the recording layer targeted for recording is changed, it is possible to recognize the plurality of first block areas, relatively easily. Namely, it is possible to preferably recognize a unit in which the first block area is changed and a point at which the recording layer targeted for recording is changed. Since the recording area of a part of the first recording layer constituting each of the first block areas has the same or substantially the same size, it is enough if the first size information is recorded once. In other words, it is unnecessary to record the first size information every time the recording layer targeted for recording is changed, which does not cause such a disadvantage that there is no more recording area in which the first size information can be recorded. Thus, it is possible to preferably continue the recording operation. Even if the information recording medium is ejected from the information recording apparatus before the finalize process, it is possible to preferably recognize the data structure on information recording medium (specially, the structures of the plurality of first block areas), by referring to the first size information recorded in the size area, even in the case where the record information is alternately recorded in respective recording layers. Therefore, on the basis of the recognized structure, it is possible to preferably continue the recording operation.

**[0031]** Consequently, according to the information recording apparatus of the present invention, it is possible to reduce a time length required for the finalize process, and it is also possible to preferably recognize a structure of how the record information is recorded, even if the record information is recorded into each recording layer. Thus, it is possible to preferably record the record information.

**[0032]** Incidentally, in response to the various aspects of the information recording medium of the present in-

vention described above, the information recording apparatus of the present invention can adopt various aspects.

**[0033]** In one aspect of the information recording apparatus of the present invention, the first controlling device controls the recording device to record the record information by the unit of the first block area in which the recording area on the second recording layer located at the position facing the recording area of the first size on the first recording layer has substantially the first size.

**[0034]** According to this aspect, by virtue of the operation of the first controlling device, the record information is recorded by the unit of the first block area including the recording area having the first size of a part of the second recording layer. In other words, the record information is recorded such that the recording area of a part of the first recording layer and the recording area of a part of the second recording layer, which constitute the first block, have the same or substantially the same size.

Therefore, it is possible to substantially uniform the size of the record information recorded into the first recording layer and the size of the record information recorded into the second recording layer. Thus, it is possible to reduce the size of an area or eliminate the area in which the dummy data needs to be recorded in the finalize process.

**[0035]** In another aspect of the information recording apparatus of the present invention, it is further provided with a third controlling device for controlling the recording device to record the record information by a unit of a second block area which includes a recording area of a second size, which is different from the first size, on the first recording layer and a recording area on the second recording layer located at a position facing the recording area of the second size on the first recording layer.

**[0036]** According to this aspect, it is unnecessary to record the record information into the first block areas, all of which have the same size, throughout the entire information recording medium. In other words, by virtue of the operation of the third controlling device, the record information is recorded into the second block areas, each of which is provided with a recording area having the second size, different from the first size which is the size of the recording area of a part of the first recording layer constituting the first block area. Therefore, it is possible to perform the recording operation, more flexibly, in accordance with features, such as the type and the size of the record information to be recorded.

**[0037]** Then, the second block area has the same structure as that of the first block area, so that it is possible to receive the above-mentioned various benefits.

**[0038]** In an aspect of the information recording apparatus provided with the third controlling device, as described above, the third controlling device may control the recording device to record the record information by the unit of the second block area in which the recording area on the second recording layer located at the position facing the recording area of the second size on the first recording layer has substantially the second size.

**[0039]** According to this aspect, by virtue of the operation of the third controlling device, the record information is recorded by the unit of the second block area including the recording area having the second size of a part of the second recording layer. In other words, the record information is recorded such that the recording area of a part of the first recording layer and the recording area of a part of the second recording layer, which constitute the second block area, have the same or substantially the same size. Therefore, it is possible to substantially uniform the size of the record information recorded into the first recording layer and the size of the record information recorded into the second recording layer. Thus, it is possible to reduce the size of an area or eliminate the area in which the dummy data needs to be recorded in the finalize process.

**[0040]** In an aspect of the information recording apparatus provided with the third controlling device, as described above, the second controlling device may control the recording device to record second size information which indicates the second size, as the record information.

**[0041]** By virtue of such construction, even in the second block area, the second size information is recorded, as in the first size information of the first block area, by the operation of the second controlling device. Therefore, it is possible to recognize the structure of the second block area, relatively easily and preferably, by referring to the second size information.

**[0042]** In another aspect of the information recording apparatus of the present invention, the first controlling device controls the recording device to record the record information by the unit of the first block area, by performing a layer jump, which is to change the recording layer targeted to record the record information, for each first size.

**[0043]** According to this aspect, it is possible to preferably control the operation of the layer jump, and it is possible to preferably record the record information by the unit of the first block area (or the second block area).

**[0044]** Incidentally, by performing the layer jump, the recording layer targeted to record the record information therein is changed from the first recording layer to the second recording layer, or from the second recording layer to the first recording layer. For example, the recording target of the recording information is changed to the recording area of the second recording layer facing the recording area of the first recording layer which is the previous recording target immediately before the layer jump.

**[0045]** In another aspect of the information recording apparatus of the present invention, the second controlling device controls the recording device to record the first size information into a recording management area into which recording management information for managing recording of the record information is recorded.

**[0046]** According to this aspect, the first size information (or the second size information) is recorded into the

recording management area into which the recording management information for managing the recording of the record information is recorded. Thus, even in the middle of the recording operation, it is possible to preferably recognize a state on the information recording medium. As a result, it is possible to preferably record the record information.

**[0047]** In another aspect of the information recording apparatus of the present invention, it is further provided with a preparing device for preparing control information (e.g. file system information) to control at least one of recording and reproduction of the record information, on the basis of at least one of the first size information and the second size information.

**[0048]** According to this aspect, it is possible to recognize the data structure (particularly, a structure relating to a point at which the recording layer targeted for recording is changed) of the first block area (or second block area) indicated by the first size information (or second size information), relatively easily. Therefore, it is possible to prepare the control information, relatively easily.

**[0049]** The above object of the present invention can be also achieved by an information recording method in an information recording apparatus, provided with: a recording device for recording record information onto an information recording medium, provided with a first recording layer and a second recording layer in which the record information can be recorded, the information recording method provided with: a first controlling process of controlling the recording device to record the record information by a unit of a first block area which includes a recording area of a first size on the first recording layer and a recording area on the second recording layer located at a position facing the recording area of the first size on the first recording layer; and a second controlling process of controlling the recording device to record first size information which indicates the first size, as the record information, into at least one of the first recording layer and the second recording layer.

**[0050]** According to the information recording method of the present invention, it is possible to receive the same various benefits as those of the above-mentioned information recording apparatus of the present invention.

**[0051]** Incidentally, in response to the various aspects of the information recording apparatus of the present invention described above, the information recording method of the present invention can adopt various aspects.

(Computer Program)

**[0052]** The above object of the present invention can be also achieved by a computer program for recording control to control a computer provided in above-mentioned information recording apparatus of the present invention (including its various aspects), to make the computer function as at least one of the first controlling device

and the second controlling device.

**[0053]** According to the computer program of the present invention, the above-mentioned information recording apparatus of the present invention can be relatively easily realized as a computer reads and executes the computer program from a program storage device, such as a ROM, a CD-ROM, a DVD-ROM, and a hard disk, or as it executes the computer program after downloading the program through a communication device.

**[0054]** Incidentally, in response to the various aspects of the information recording apparatus of the present invention described above, the computer program of the present invention can adopt various aspects.

**[0055]** The above object of the present invention can be also achieved by a computer program product in a computer-readable medium for tangibly embodying a program of instructions executable by a computer provided in the above-mentioned information recording apparatus of the present invention (including its various aspects), to make the computer function as at least one of the first controlling device and the second controlling device.

**[0056]** According to the computer program product of the present invention, the above-described information recording apparatus of the present invention can be embodied relatively readily, by loading the computer program product from a recording medium for storing the computer program product, such as a ROM (Read Only Memory), a CD-ROM (Compact Disc - Read Only Memory), a DVD-ROM (DVD Read Only Memory), a hard disk or the like, into the computer, or by downloading the computer program product, which may be a carrier wave, into the computer via a communication device. More specifically, the computer program product may include computer readable codes to cause the computer (or may be provided with computer readable instructions for causing the computer) to function as the above-described information recording apparatus.

**[0057]** These effects and other advantages of the present invention will become more apparent from the following embodiments.

**[0058]** As explained above, the information recording medium of the present invention includes the plurality of block areas, each of which includes a part of the first recording layer having the first size and a part of the second recording layer, and is provided with the size area to record therein the size information which indicates the first size. Therefore, it is possible to reduce a time length required for the finalize process, and it is also possible to preferably record the record information even if the record information is recorded into each recording layer.

**[0059]** Moreover, the information recording apparatus of the present invention is provided with the recording device, the first controlling device, and the second controlling device. The information recording method of the present invention is provided with the first controlling process and the second controlling process. Therefore, it is possible to reduce a time length required for the fi-

nalize process, and it is also possible to preferably record the record information even if the record information is recorded into each recording layer.

## 5 Brief Description of Drawings

### **[0060]**

**[FIG. 1]** FIG. 1(a) and FIG. 1(b) are a substantial plan view showing the basic structure of an optical disc having a plurality of recording areas in an embodiment of an information recording medium of the present invention (FIG. 1(a)), and a schematic cross sectional view of the optical disc and a corresponding conceptual diagram showing a recording area structure in the radial direction (FIG. 1(b)).

**[FIG. 2]** FIG. 2 is an explanatory diagram conceptually showing an aspect of the recording of data onto the optical disc.

**[FIG. 3]** FIG. 3 is a data structural view conceptually showing the data structure of RMD (Recording Management Data) including data, such as a layer jump interval, to be recorded into a RMA.

**[FIG. 4]** FIG. 4 is a data structural view conceptually showing a recording aspect of recording the data so as to include a plurality of recording sections in one border area.

**[FIG. 5]** FIG. 5 is a data structural view conceptually showing a recording aspect of recording the data so as to associate one recording section with one border area.

**[FIG. 6]** FIG. 6 is a data structural view showing an optical disc provided with a plurality of R\_Zones on a user data area.

**[FIG. 7]** FIG. 7 is a block diagram conceptually showing the basic structure of an embodiment of an information recording apparatus of the present invention.

**[FIG. 8]** FIG. 8 is a flowchart conceptually showing an entire flow of the recording operation of an information recording / reproducing apparatus in the embodiment.

**[FIG. 9]** FIG. 9 is a data structural view showing one procedure of the recording operation.

**[FIG. 10]** FIG. 10 is a data structural view showing another procedure of the recording operation.

## 55 Description of Reference Codes

### **[0061]**

100, 100a	optical disc
101, 111	file system
102	lead-in area
103, 113	PCA
104, 114	RMA
105, 115	user data area
106, 116	border-in area
107, 117	border-out area
118	lead-out area
109, 119	middle area
121	layer jump interval
200	information recording / reproducing apparatus
300	disc drive
352	optical pickup
354	CPU
359	CPU
400	host computer

#### Best Mode for Carrying Out the Invention

**[0062]** Hereinafter, the best mode for carrying out the invention will be explained in order in each embodiment with reference to the drawings.

**[0063]** Hereinafter, embodiments of the present invention will be explained with reference to the drawings.

#### (Embodiment of the Information Recording Medium)

**[0064]** At first, with reference to FIGs. 1,3 and 6, an embodiment according to the information recording medium of the present invention will be discussed.

**[0065]** At first, with reference to FIG. 1(a) and FIG. 1(b), the basic structure of an optical disc in the embodiment of the recording medium of the present invention will be discussed. FIG. 1(a) is a substantial plan view showing the basic structure of an optical disc having a plurality of recording areas in the embodiment of the information recording medium of the present invention, and FIG. 1(b) is a schematic cross sectional view of the optical disc and a corresponding conceptual diagram showing a recording area structure in the radial direction.

**[0066]** As shown in FIG. 1(a) and FIG. 1(b), an optical disc 100 has a recording surface on a disc main body with a diameter of about 12 cm, as is a DVD. On the recording surface, the optical disc 100 is provided with: a lead-in area 102 and a lead-out area 118; user data areas 105 and 115; and middle areas 109 and 119, with a center hole 101 as the center. Then, for example, on a transparent substrate 110 of the optical disc 100, there are laminated recording layers and the like. In each recording area of the recording layers, tracks, such as groove tracks and land tracks, are alternately placed, spirally or concentrically, with the center hole 101 as the center. On the track, data is divided and recorded by a unit of ECC block. The ECC block is a data management unit by a pre-format address in which record information is error-correctable.

**[0067]** Incidentally, the present invention is not particularly limited to the optical disc having these three areas. For example, even if the lead-in area 102, the lead-out area 118 or the middle area 109 (or 119) does not exist, a data structure explained below can be constructed. Moreover, as described later, the lead-in area 102, the lead-out area 118 or the middle area 109 (or 119) may be further segmented.

**[0068]** Particularly, the optical disc 100 in the embodiment, as shown in FIG. 1(b), has such a structure that a L0 layer which constitutes one example of the "first recording layer" of the present invention and a L1 layer which constitutes one example of the "second recording layer" of the present invention are laminated on the transparent substrate 110. Upon the recording and reproduction of such a two-layer type optical disc 100, the recording and reproduction in the L0 layer or the L 1 layer is performed, depending on which recording layer has the focus position of laser light LB, irradiated from the lower to upper side in FIG. 1(b). In particular, the data is recorded from the inner to the outer side in the L0 layer, and the data is recorded from the outer to the inner side in the L 1 layer. In other words, the optical disc 100 in the embodiment corresponds to an optical disc in an opposite track path manner. However, even an optical disc in a parallel track path manner can receive various benefits described later, by adopting the structure discussed below.

**[0069]** Moreover, the optical disc 100 in the embodiment is provided with: PCAs (Power Calibration Areas) 103 and 113; and RMAs (Recording Management Areas) 104 and 114, on the inner side of each of the lead-in area 102 and the lead-out area 118.

**[0070]** The PCAs 103 and 113 are recording areas to perform an OPC (Optimum Power Control) process of adjusting (i.e. calibrating) the laser power of laser light LB in recording the data onto the optical disc 100. An OPC pattern is recorded into the PCAs 103 and 113 with changing the laser power gradually, and the reproduction quality (e.g. asymmetry, etc.) of the recorded OPC pattern is measured, to thereby calculate an optimum laser power in recording the data.

**[0071]** The RMAs 104 and 114 are recording areas to record therein various management information for managing the recording of the data onto the optical disc 100.

**[0072]** Moreover, the optical disc 100 in the embodiment is not limited to a two-layer single sided type, i.e., a dual layer type, but may be a two-layer double sided type, i.e., a dual layer double sided type. Furthermore, the optical disc 100 in the embodiment is not limited to the optical disc having the two recording layers, as described above, but may be an optical disc of a multilayer type which has three or more layers.

**[0073]** Next, with reference to FIG. 2, an aspect of the recording of data onto the optical disc 100 will be discussed in more details. FIG. 2 is an explanatory diagram conceptually showing the aspect of the recording of the data onto the optical disc.

**[0074]** As shown in FIG. 2, the optical disc 100 has two recording layers (i.e. the L0 layer and the L1 layer). The L0 layer is provided with: the lead-in area 102; and the middle area 109. The L1 layer is provided with: the lead-out area 118; and the middle area 119. Moreover, file system information 101 is recorded between the user data area 105 and the lead-in area 102, and file system information 111 is recorded between the lead-out area 118 and the user data area 115. Then, the recording areas in which the file system information 101 and 111 is recorded are assigned as an R\_Zone (Record Zone) #1. Moreover, the user data areas 105 and 115 are assigned as an R\_Zone #2.

**[0075]** In particular, there are a plurality of recording sections (one specific example of the "first block area" and the "second block area" of the present invention) in the user data areas 105 and 115 in the L0 layer and the L1 layer, respectively. Each recording section is provided with a partial user data area 105a, 105b, or 105c, and a partial user data area 115a, 115b, or 115c, which constitutes one portion of the user data area 105 or 115. For example, a first recording section is provided with the partial user data area 105a and the partial user data area 115a which faces the partial user data area 105a. A second recording section is provided with the partial user data area 105b and the partial user data area 115b which faces the partial user data area 105b. A third recording section is provided with the partial user data area 105c and the partial user data area 115c which faces the partial user data area 105c. In this case, for example, the partial user data area 105a and the partial user data area 115a may have the same position relationship as viewed from the irradiation or emission side of laser light LB. In other words, since the optical disc 100 is in the opposite track path manner, the address value of the partial user data area 105a and the address value of the partial user data area 115a may have a complement relationship with each other. However, even if the partial user data area 105a and the facing partial user data area 115a do not have the same position relationship, strictly, as viewed from the irradiation side of the laser light LB, they may have a position relationship which can be substantially equated as the same position relationship. Alternatively, if they have a position relationship which does not influence the recording operation and the reproduction operation, some discrepancy or mismatch is more or less allowed.

**[0076]** Then, content data, such as movie data and audio data, and other various data are recorded by a unit of the recording section. In other words, for example, some movie data (or file) is recorded into the first recording section. For example, some audio data (or file) is recorded into the second recording section. For example, some data for PC (or file) is recorded into the third recording section. In particular, the data is firstly recorded into the first recording section, the data is secondly recorded into the second recording section, and the data is thirdly recorded into the third recording section. Then,

since the optical disc 100 is in the opposite track path manner, the data is recorded from the inner circumferential side to the outer circumferential side in the L0 layer in respective recording sections. On the other hand, the data is recorded from the outer circumferential side to the inner circumferential side in the L1 layer in respective recording sections. In other words, the data is recorded in a direction shown with arrows in FIG. 2.

**[0077]** Moreover, some single data (file) may be recorded over a plurality of recording sections. In other words, one portion of the single data may be recorded into the entire first recording section, and then, the rest of the single data may be recorded into at least one portion of the second recording section. In short, the data may be recorded by the unit of recording section, from the first recording section, in order.

**[0078]** Particularly, the plurality of recording sections have the same or substantially the same size. Discussing this in more detail, the partial user data areas 105a, 105b, and 105c of the L0 layer in the plurality of recording sections have the same or substantially the same size. Moreover, the partial user data areas 115a, 115b, and 115c of the L1 layer in the plurality of recording sections have the same or substantially the same size. Since the partial user data area 105a (or 105b or 105c) of the L0 layer and the partial user data area 115a (or 115b or 115c) of the L0 layer, which face each other, constitute one recording section, the partial user data area 105a (or 105b or 105c) of the L0 layer and the partial user data area 115a (or 115b or 115c) of the L0 layer, which face each other, have the same or substantially the same size. In other words, a layer jump operation of changing the recording layer, which is targeted to record the data, from the L0 layer to the L1 layer is performed at regular intervals.

**[0079]** The size of each recording section in the L0 layer and the L1 layer (i.e. which is the size of each of the partial user data areas 105a, 105b, 105c, 115a, 115b, and 115c, and which is an interval at which the layer jump operation is performed) is recorded in the RMA 104 (or 114), as the "layer jump interval" which constitutes one specific example of the "first size information" and the "second size information" of the present invention. The "layer jump interval" will be discussed in more detail, with reference to FIG. 3. FIG. 3 is a data structural view conceptually showing the data structure of RMD (Recording Management Data) including data, such as the layer jump interval, to be recorded into the RMA 104 (or 114).

**[0080]** As shown in FIG. 3, a layer jump interval 121 is recorded in the RMA 104 (or 114). Discussing the format of a DVD, which is one specific example of the optical disc 100, as an example, the layer jump interval 121 is recorded in a recording area with byte positions of "14" to "15" in a field 3 of the RMD in a format 4 recorded in the RMA 104 (or 114). Namely, the recording area with byte positions of "14" to "15" constitutes one specific example of the "size area" of the present invention.

**[0081]** The layer jump interval 121 is data having a size

of 2 bytes, and indicates the size of each of the partial user data areas 105a, 105b, 105c, 115a, 115b, and 115c in respective recording sections (i.e. the interval at which the layer jump operation is performed). For example, if the layer jump interval 121 indicates a size corresponding to 1000 ECC blocks, the size of each of the partial user data areas 105a, 105b, 105c, 115a, 115b, and 115c in respective recording sections is 1000 ECC blocks. Then, the layer jump operation is performed every time the data of 1000 ECC blocks is recorded.

**[0082]** Incidentally, the field 3 of the RMD has recorded various data in addition to the layer jump interval 121. For example, the data which indicates an invisible R\_Zone number is recorded in a recording area with byte positions of "0" to "1". The data which indicates a first open R\_Zone number is recorded in a recording area with byte positions of "2" to "3". The data which indicates a second open R\_Zone number is recorded in a recording area with byte positions of "4" to "5". The data which indicates the start sector number of the R\_Zone #1 is recorded in a recording area with byte positions of "16" to "19". The data which indicates the layer jump address of the R\_Zone #1 is recorded in a recording area with byte positions of "20" to "23". The data which indicates the end sector number of the R\_Zone #1 is recorded in a recording area with byte positions of "24" to "27". The data which indicates the last recorded address of the R\_Zone #1 is recorded in a recording area with byte positions of "28" to "31". The data which indicates the start sector number of the R\_Zone #2 is recorded in a recording area with byte positions of "32" to "35". After this, the data which indicates the layer jump address, the end sector number, the last recorded address or the like is recorded even for the R\_Zone #2, as in the R\_Zone #1. Moreover, if there are R\_Zones #3, #4, and the like, the same data is recorded, even for the R\_Zones #3, #4, and the like.

**[0083]** Moreover, a recording area with byte positions of "6" to "13" is ensured as a reserved area used for function enhancement in the future.

**[0084]** As described above, in such construction that the data is recorded into each of the plurality of recording sections, it is possible to sequentially record the data from the inner circumferential side in each of the L0 layer and the L 1 layer. Thus, there is an advantage that in the finalize process of the optical disc, a time length required for the process is relatively reduced. In particular, in the case of the optical disc in such an aspect that the data is recorded into the L 1 layer after recorded into the whole L0 layer, there is such a technical problem that it takes relatively longer time to finalize, as compared to the amount of data recorded on the whole optical disc, because the data is recorded in the whole L0 layer and the data is hardly recorded in the L1 layer. This is because it needs a time length to record the dummy data into an area in which the data is not recorded in the L1 layer. However, according to the embodiment, the various data is recorded in each recording section, so that it is possible

to record the data, substantially uniformly, into each of the L0 layer and the L 1 layer. Therefore, it is unnecessary to record the dummy data in the L1 layer, as described above. In other words, on the outer circumferential side of the middle areas 109 and 119, an unrecorded state (or mirror state) will be admissible. Thus, it is possible to reduce the time length for the finalize process, so that it is possible to contribute the reduction of a recording operation time and the improvement of the comfortableness of a user, and the like.

**[0085]** Since each recording section has the same or substantially the same size, it is possible to recognize each recording section even if a disc drive and a host computer or the like, described later, do not store therein a point at which the recording layer targeted for recording is changed (i.e. a layer jump point). Moreover, since each recording section has the same or substantially the same size, it is enough if the layer jump interval 121 is recorded into the RMA 104 (or 114) once. In other words, it is unnecessary to record the RMD every time the recording layer targeted for recording is changed, which does not cause a disadvantage that there is no more recordable recording area out of the RMA 104 (or 114). Thus, it is possible to continue the recording operation.

**[0086]** Then, even if the optical disc 100 is ejected from the disc drive before the finalize process, it is possible to preferably recognize a data structure on the optical disc 100 (specially, the structure of each recording section), by referring to the layer jump interval 121 recorded in the RMA 104 (or 114), even in the case where the data is alternately recorded in respective recording layers. Namely, it is possible to obtain the size of each recording section from the layer jump interval 121, so that it is possible to recognize the data structure on the optical disc 100 (specially, the structure of each recording section), preferably and relatively easily, by performing a predetermined operation or calculation process.

**[0087]** Incidentally, with reference to FIG. 4 and FIG. 5, the more detailed data structure of the optical disc 100 will be discussed. Specifically, an aspect of recording the data by using a border area will be discussed. FIG. 4 is a data structural view conceptually showing a recording aspect of recording the data so as to include a plurality of recording sections in one border area. FIG. 5 is a data structural view conceptually showing a recording aspect of recording the data so as to associate one recording section with one border area.

**[0088]** As shown in FIG. 4, the data may be recorded so as to include a plurality of recording sections in one border area. For example, in FIG. 4, a first border area includes a first recording section and a second recording section. A second border area includes a third recording section and a fourth recording section.

**[0089]** Now, the first and second border areas will be discussed in more detail. The first border area is provided with: partial user data areas 105a, 105b, 115a, and 115b; and border-out areas 107a and 117a. Moreover, the second border area is provided with: border-in areas 106a

and 116b; partial user data areas 105c, 105d, 115c, and 115d; and border-out areas 107b and 117b. Incidentally, the first border area is not provided with the border-in area, as in the second border area; however, an extra border-in area (or an extra border zone) included in the lead-in area 102 or the lead-out area 118 has a function as the border-in area in the first border area. By forming such a border-in area and border-out area, it is possible to reproduce the information recorded on the optical disc 100 on a multi-border-compliant information reproducing apparatus (ROM player) or the like.

**[0090]** The border-in areas 106 and 116 are recording areas to record therein various management information for managing the data recorded in each border area, and have a size of about several m in the radial direction of the optical disc 100, for example.

**[0091]** Specifically, the newest or updated physical format information is recorded in the border-in areas 106 and 116. The newest physical format information indicates distribution information (e.g. mapping information, etc.) of the data in the corresponding border area. The newest physical format information has a size corresponding to 5 ECC blocks; however, it is not limited this size.

**[0092]** The border-out areas 107 and 117 are areas to record therein various control information for controlling the recording operation in recording the data into each border area and the reproduction operation in reproducing the recorded data, and have a size of about 100 m to 500 m in the radial direction of the optical disc 100, for example.

**[0093]** Specifically, an RMD copy, a stop block, a next border marker, and the like is recorded in the border-out areas 107 and 117.

**[0094]** The RMD copy is information for managing the recording of data, and includes the same information as the RMD recorded in the RMA 104 (or 114). The RMD copy can provide information (i.e. the RMD) for reproducing the various data recorded in the border area, for an information reproducing apparatus (ROM player) which cannot read the RMD in the RMA 104 (or 114) on a DVD-R, for example.

**[0095]** The stop block includes flag information having a size of 2 ECC blocks, and indicates whether or not the data is recorded after the border-out area 107 (or 117). Namely, if the information reproducing apparatus for reproducing the data recorded on the optical disc 100 judges by the stop block that the data is not recorded, it does not read the subsequent area.

**[0096]** The next border marker is information used by an information recording apparatus for recording the data onto the optical disc. For example, the next border marker is indicated by recording three of the data having a size of 2 ECC blocks. Specifically, if the data is further recorded following the border-out area 107 (or 117), predetermined data (e.g. "00h") is recorded as the next border marker. On the other hand, if the data is not further recorded following the border-out area 107 (or 117), the

next border marker is not recorded, and the recording area of one portion of the border-out area 107 (or 117) (specifically, the recording area of the latter half of the border-out area 107 (or 117)) is in the mirror state (i.e. unrecorded).

**[0097]** Moreover, as shown in FIG. 5, the data may be recorded so as to include one recording section in one border area. For example, in FIG. 5, a first border area includes a first recording section, a second border area includes a second recording section, and a third border area includes a third recording section. The first border area, the second border area and the third border area in FIG. 5 also have the same data structure as those of the first and second border areas shown in FIG. 4. In other words, the border-in areas 106 and 116, and the border-out areas 107 and 117 are provided.

**[0098]** Incidentally, the border-out areas 107 and 117 are disposed in the L0 layer and the L1 layer, respectively, at a point where the recording layer targeted to record the data therein is changed from the L0 layer to the L1 layer. By providing the border-out areas 107 and 117 at this point, it is possible to prevent a penetration (i.e. a flying-over) of an optical pickup (or the penetration of the laser light irradiated from the optical pickup) which searches for a predetermined recording position on the optical disc 100. The "penetration" herein indicates that in the case where the optical disc 100 is provided only with the first border area, when the partial user data area 105a is searched, the search destination jumps out of the partial user data area 105a into a recording area in which the data is unrecorded (e.g. the mirror area). This type of penetration of the optical pickup may cause the runaway of the subsequent recording operation and reproduction operation, which is not preferable. However, since the border-out areas 107 and 117 are provided, it is possible to properly prevent the penetration. In addition, by virtue of the border-out areas 107 and 117, it is possible to prevent the laser light from entering a recording area in which the data is unrecorded, after layer jump, which is caused by a discrepancy in pasting and an eccentricity between the two recording layers, or which is caused by a discrepancy of the irradiation position of the laser light, in performing the "layer jump" which is a change operation of changing the recording layer targeted for recording, between the L0 layer and the L1 layer.

**[0099]** Moreover, in consideration of the eccentricity and the like, for example, it may be constructed to make the size of the partial user data area 105a in the L0 layer larger than the size of the partial user data area 115a in the L1 layer. Particularly, it is preferable to make the size of the partial user data area 105a in the L0 layer larger than the size of the partial user data area 115a in the L1 layer so that the partial user data area 115a in the L1 layer is disposed only at a position facing the partial user data area 105a in the L0 layer. By this, if the data is recorded into the L1 layer, the laser light can be always irradiated through the L0 layer in which the data is recorded, so that it is possible to improve recording fea-

tures. Obviously, the same is true for the other partial user data areas 105b, 105c, 105d, 115b, 115c, 115d, or the like.

[0100] Moreover, in the aspect of recording the data by using the border area, as shown in FIG. 4 and FIG. 5, the R\_Zone to which the partial user data area included in one border area belongs and the R\_Zone to which the partial user data area included in another border area belongs are different. In other words, in FIG. 4, the partial user data areas 105a and 115a included in the first border area belong to an R\_Zone #2. The partial user data areas 105b and 115b included in the second border area belong to an R\_Zone #3. In FIG. 5, the partial user data areas 105a and 115a included in the first border area belong to an R\_Zone #2. The partial user data areas 105b and 115b included in the second border area belong to an R\_Zone #3. The partial user data areas 105c and 115c included in the third border area belong to an R\_Zone #4. More R\_Zones may be provided on the user data areas 105 and 115. Obviously, it is not limited to the aspect of recording the data by using the border area, but the aspect of recording the data by using more R\_Zones may be admissible. An aspect of providing the plurality of R\_Zones will be discussed in more detail, with reference to FIG. 6. FIG. 6 is a data structural view showing an optical disc 100a provided with a plurality of R\_Zones on the user data areas 105 and 115.

[0101] As shown in FIG. 6, on the user data areas 105 and 115, two R\_Zone #2 and R\_Zone #3 may be assigned. In this case, the recording sections in the R\_Zone #2 and the recording sections in the R\_Zone #3 do not necessarily have the same or substantially the same size. Namely, the partial user data area 105a (105b, 105c, 115a, 115b, or 115c) in the R\_Zone #2 and the partial user data area 105d (105e, 105f, 115d, 115e, or 115f) in the R\_Zone #3 do not necessarily have the same or substantially the same size. However, the first recording section and the second recording section in the R\_Zone #2 have the same or substantially the same size. The third recording section and the fourth recording section in the R\_Zone #3 have the same or substantially the same size. Namely, the partial user data areas 105a, 105b, 105c, 115a, 115b, and 115c in the R\_Zone #2 have the same or substantially the same size, and the partial user data areas 105f, 105e, 105f, 115d, 115e, and 115f in the R\_Zone #3 have the same or substantially the same size.

[0102] In this case, both the RMD corresponding to the R\_Zone #2 and the RMD corresponding to the R\_Zone #3 are recorded into the RMA 104 (or 114). In other words, the layer jump interval 121 corresponding to the R\_Zone #2 and the layer jump interval 121 corresponding to the R\_Zone #3 are recorded into the RMA 104 (or 114).

[0103] Even in such construction, it is possible to receive the above-mentioned various benefits because each of the R\_Zones has the same structure as in the above-mentioned disc 100.

[0104] Incidentally, the number of the R\_Zones on the user data areas 105 and 115 is not limited to two or three,

as described above, but may be more. Even in that case, it is possible to receive the above-mentioned various benefits by adopting the same structure as in the above-mentioned optical disc 100, for each of the R\_Zones.

(Embodiment of Information Recording / Reproducing Apparatus)

[0105] Next, the structure and operation of an information recording /reproducing apparatus, which is an embodiment of the information recording apparatus of the present invention, will be explained with reference to FIG. 7 to FIG. 10.

(1) Basic Structure

[0106] At first, with reference to FIG. 7, the basic structure of an information recording / reproducing apparatus 200 in the embodiment will be discussed. FIG. 7 is a block diagram conceptually showing the basic structure of the information recording / reproducing apparatus 200 in the embodiment. Incidentally, the information recording / reproducing apparatus 200 has a function of recording the record data onto the optical disc 100 and a function of reading the record data recorded on the optical disc 100.

[0107] As shown in FIG. 7, the information recording / reproducing apparatus 200 is provided with: a disc drive 300 onto which the optical disc 100 is actually loaded; and a host computer 400, such as a personal computer, for controlling the recording and reproduction of the data with respect to the disc drive 300.

[0108] The disc drive 300 is provided with: the optical disc 100; a spindle motor 351; an optical pickup 352; a signal recording / reproducing device 353; a CPU (drive control device) 354; a memory 355; a data input / output device 306; and a bus 357. Moreover, the host computer 400 is provided with: a CPU 359; a memory 360; an operation / display control device 307; an operation button 310; a display panel 311; and a data input / output control device 308.

[0109] The spindle motor 351 is intended to rotate and stop the optical disc 100, and operates upon accessing the optical disc. More specifically, the spindle motor 351 is constructed to rotate the optical disc 100 at a predetermined speed and stop, under spindle servo from a not-illustrated servo unit or the like.

[0110] The optical pickup 352 is one specific example of the "recording device" of the present invention. The optical pickup 352 is to perform the recording /reproduction with respect to the optical disc 100, and is provided with a semiconductor laser device, a lens, and the like. More specifically, the optical pickup 352 irradiates the optical disc 100 with a light beam, such as a laser beam, as reading light with a first power upon reproduction, and as writing light with a second power upon recording, with it modulated.

[0111] The signal recording / reproducing device 353 controls the spindle motor 351 and the optical pickup

352, to thereby perform the recording /reproduction with respect to the optical disc 100. More specifically, the signal recording / reproducing device 353 is provided with a laser diode (LD) driver, a head amplifier, and so on, for example. The LD driver drives a not-illustrated semiconductor laser located in the optical pickup 352. The head amplifier amplifies the output signal of the optical pickup 352, namely, the reflected light of a light beam, and outputs the amplified signal. More specifically, the signal recording / reproducing device 353 drives the not-illustrated semiconductor laser located in the optical pickup 352 in order to determine an optimum laser power by a recording process and reproduction process for the OPC pattern, along with a not-illustrated timing generator or the like, under the control of the CPU 354, at the time of OPC process.

**[0112]** The memory 355 is used in the whole data processing and the OPC process on the disc drive 300, including a buffer area for the record /reproduction data, an area used as an intermediate buffer when data is converted into the data that can be used on the signal recording / reproducing device 353, and the like. Moreover, the memory 355 is provided with: a Read Only Memory (ROM) area into which a program for performing an operation as a recording device, namely, a firmware program is stored; a buffer for temporarily storing the record reproduction data; a Random Access Memory (RAM) area into which a parameter required for the operation of a firmware program or the like is stored; and the like.

**[0113]** The CPU (drive control device) 354 is connected to the signal recording / reproducing device 353 and the memory 355 via the bus 357, and controls the entire disc drive 300 by giving an instruction to each constitutional element. In general, software for operating the CPU 354 or firmware is stored in the memory 355.

**[0114]** The data input / output control device 306 controls the input / output of the data from the exterior with respect to the disc drive 300, to thereby perform storage to and export from the data buffer on the memory 355. A drive control order, issued from the external host computer 400 which is connected with the disc drive 300 through an interface, such as a SCSI (Small Computer System Interface) and an ATAPI (AT Attachment Packet Interface), is transmitted to the CPU 354 through the data input / output control device 306. Moreover, the record / reproduction data is exchanged with the host computer 400 through the data input / output control device 306 in the same manner.

**[0115]** The operation / display control device 307 receives an operation instruction and performs display with respect to the host computer 400, and transmits an instruction by the operation button 310, such as an instruction to record or reproduce, to the CPU 359. The CPU 359 transmits a control command to the disc drive 300 through the data input / output control device 308 on the basis of instruction information from the operation / display control device 307 and controls the whole disc drive 300. In the same manner, the CPU 359 can transmit a

command to request the host to transmit an operation state, with respect to the disc drive 300. By this, the operation state of the disc drive 300, such as during recording and during reproduction, can be recognized, so that the PCU 359 can output the operation state of the disc drive 300 to the display panel 311, such as a fluorescent tube, through the operation / display control device 307.

**[0116]** The memory 360 is an internal storage apparatus used by the host computer 400. The memory 360 is provided with: ROM area into which a firmware program, such as a BIOS (Basic Input / Output System), is stored; a RAM area into which parameters required for an operating system and the operation of an application program or the like are stored; and the like. Moreover, the memory 360 may be connected to an external storage apparatus, such as a not-illustrated hard disk, through the data input / output control device 308.

**[0117]** One specific example used by combining the disc drive 300 and the host computer 400, as explained above, is household equipment, such as recorder equipment for recording and reproducing video images. The recorder equipment records a video signal from a broadcast reception tuner and an external connection terminal, onto a disc, and outputs the video signal reproduced from the disc to external display equipment, such as a television. The operation as the recorder equipment is performed by executing a program stored in the memory 360. Moreover, in another specific example, the disc drive 300 is a disc drive (hereinafter referred to as a drive), and the host computer 400 is a personal computer or a work station. The host computer, such as a personal computer, and the drive are connected through the data input / output control devices 306 and 308, such as a SCSI and an ATAPI, and application, such as writing software, installed in the host computer 400 controls the disc drive 300.

## (2) Operation Principle

**[0118]** Next, with reference to FIG. 8 to FIG. 10, the recording operation of the information recording / reproducing apparatus 200 in the embodiment will be discussed. FIG. 8 is a flowchart conceptually showing an entire flow of the recording operation of the information recording / reproducing apparatus 200 in the embodiment. Each of FIG. 9 and FIG. 10 is a data structural view showing the procedure of the recording operation.

**[0119]** As shown in FIG. 8, at first, the optical disc 100 is loaded onto the disc drive 300 (step S101). At this time, it may be constructed to calculate an optimum laser power for the recording of the data by performing the OPC process by using the PCA 103 (or 113). Alternatively, it may be constructed to read various control data necessary for the recording of the data.

**[0120]** Then, under the control of the CPU 359, which constitutes one specific example of the "first controlling device" of the present invention, the host computer 400 sets a recording mode to a layer jump recording mode

(alternate recording mode) (step S102). By setting the recording mode to the layer jump recording mode, it is possible to record the data into each recording section, as described above.

**[0121]** Then, the host computer 400 sets an open R\_Zone #1 to record the file system information 101 (or 111), with respect to the recording area on the optical disc 100 (step S103).

**[0122]** Moreover, the host computer 400 sets the layer jump interval 121, with respect to an invisible R\_Zone #2 which is set next to the open R\_Zone #1, under the control of the CPU 359 (step S104). For example, by setting 1000 ECC blocks as the layer jump interval 121, the data is recorded to perform the layer jump by a unit of 1000 ECC blocks. In other words, the layer jump is performed every time the data is recorded in the partial user data area of 1000 ECC blocks.

**[0123]** Then, the host computer 400 outputs an instruction to actually record the data onto the optical disc 100, to the disc drive 300 (step S105).

**[0124]** The disc drive 300, receiving this instruction, records information which indicates the structures of the open R\_Zone #1 and the invisible R\_Zone #2 set in the step S103 etc., the layer jump interval 121 set in the step S104, and the like, into the RMA 104 (or 114) as the RMD, under the control of the CPU 354 which is one specific example of the "second controlling device" of the present invention (step S106).

**[0125]** Then, the data is actually recorded (step S107). In other words, the data is recorded by a unit of recording section.

**[0126]** For example, as shown in FIG. 9, at first, the data is recorded into the first recording section in a direction of the arrow in FIG. 9. Namely, the data (UD 10) is recorded into the partial user data area 105a in the first recording section, and then, the data (UD 11) is recorded into the partial user data area 115a in the first recording section. Then, the data is recorded into the second recording section in a direction of the arrow in FIG. 9. Namely, the data (UD 20) is recorded into the partial user data area 105b in the second recording section, and then, the data (UD 21) is recorded into the partial user data area 115b in the second recording section. Moreover, the data is recorded into the third recording section in a direction of the arrow in FIG. 9. Namely, the data (UD30) is recorded into the partial user data area 105c in the third recording section, and then, the data (UD31) is recorded into the partial user data area 115c in the third recording section. At this time, the size of each recording section (i.e. the size of each of the partial user data areas 105a, 105b, 105c, 115a, 115b, and 115c in respective recording sections) is a size indicated by the layer jump interval 121 set in the step S104 in FIG. 8. In other words, by performing the layer jump for each layer jump interval 121 set in the step S104 in FIG. 8, the data is recorded by the unit of the recording section shown in FIG. 9.

**[0127]** In FIG. 8 again, after the recording of the data, the host computer 400 prepares the file system informa-

tion 101 (or 111) on the basis of the layer jump interval 121 or the like (step S108). The file system information 101 (or 111) includes information which indicates the data structure on the optical disc 100 (specially, the structure of each recording section, etc.) and the like. The, the prepared file system information 101 (or 111) is recorded into the open R\_Zone #1 set in the step S102.

**[0128]** Then, the host computer 400 performs a finalize process (step S109). This finalize process is a process to allow the information recorded on the optical disc by the information recording apparatus, such as a DVD-R/RW recorder, to be reproduced by the information reproducing apparatus, such as a DVD-ROM player.

**[0129]** Specifically, as shown in FIG. 10, various necessary management information or the like is recorded into the lead-in area (LI) 102 and the lead-out area (LO) 118. Then, the middle areas 109 and 119 are prepared on the most outer circumferential side of the area in which the data is recorded. Into the middle areas 109 and 119, for example, the "00h" data is recorded. Moreover, since the data is not recorded in the entire partial user data area 115c in the third recording section (i.e. there is a recording area in which the data is unrecorded in the partial user data area 115c), padding data (PD) is recorded into the recording area in which the data is unrecorded. Incidentally, the padding data is "00h" data, for example. However, the padding data is not limited to this if some recording pits are formed. The same is true for the "00h" data recorded into the middle area 109 (or 119) mentioned above.

**[0130]** Here, if the data is recorded into the L1 layer after recorded into the entire L0 layer, it is necessary to record the dummy data into an area in which the data is unrecorded. This is a necessary process to maintain compatibility with a reproduce-only optical disc, such as a DVD-ROM. Therefore, it is assumed that 5GB data is recorded onto an optical disc on which each of the L0 layer and the L1 layer has a recording capacity of 4GB, 4GB of the data is recorded into the L0 layer, and 1GB of the data is recorded into the L1 layer. In this case, it is necessary to record the dummy data into a remaining space area with 3 GB in the L1 layer. This causes an increase in a time length required for the finalize process.

**[0131]** In the embodiment, however, the data is recorded, substantially uniformly, into each of the L0 layer and the L1 layer. In other words, the data is recorded until substantially the same radius position in each of the L0 layer and the L1 layer. For example, it is assumed that 5GB data is recorded onto an optical disc on which each of the L0 layer and the L1 layer has a recording capacity of 4GB, 2.5GB of the data is recorded into each of the L0 layer and the L1 layer. Therefore, it is unnecessary to record the dummy data into an unrecorded area, and it is enough if the middle area is prepared in the most outer circumferential area in which the data is recorded, as described above. Thus, there is such a great advantage that it is possible to reduce the time length required for the finalize process.

**[0132]** Since each recording section has the same or substantially the same size, it is possible to recognize each recording section even if the disc drive 300 and the host computer 400 do not store therein a point at which the recording layer targeted for recording is changed (i.e. the layer jump point). Moreover, since each recording section has the same or substantially the same size, it is enough if the layer jump interval 121 is recorded into the RMA 104 (or 114) once. In other words, it is unnecessary to record the RMD every time the recording layer targeted for recording is changed, which does not cause a disadvantage that there is no more recordable recording area out of the RMA 104 (or 114). Thus, it is possible to continue the recording operation.

**[0133]** Then, even if the optical disc 100 is ejected from the disc drive 300 before the finalize process, it is possible to preferably recognize the data structure on the optical disc 100 (specially, the structure of each recording section), by referring to the layer jump interval 121 recorded in the RMA 104 (or 114), even in the case where the data is alternately recorded in respective recording layers. Namely, it is possible to obtain the size of each recording section from the layer jump interval 121, so that it is possible to recognize the data structure on the optical disc 100 (specially, the structure of each recording section), preferably and relatively easily, by performing a predetermined operation or calculation process, on the host computer 400 (or the disc drive 300).

**[0134]** Moreover, a method of recording the data into the same or substantially the same recording section (i.e. of a fixed length size) as described above will be briefly discussed. In this case, it is judged whether or not the size of the data to be recorded in the recording operation is larger than the size of the recording section.

**[0135]** As a result of the judgment, if it is judged that the size of the recording section is larger, the data to be recorded is recorded into one portion of the recording section.

**[0136]** On the other hand, if it is judged that the data to be recorded is larger, one portion of the data to be recorded is recorded into the entire one recording section. Then, the rest of the data to be recorded which is not recorded yet is recorded into one portion of another recording section. More specifically, if the size of each recording section is 10MB and the size of the data to be recorded is 15MB, 10MB of the data is recorded into one recording section, and 5MB of the data is recorded into another recording section. Obviously, if the data larger than the total size of the two recording sections is recorded, one portion of the data may be recorded into all of the one recording section and the other section, and furthermore, the rest of the data may be recorded into another recording section.

**[0137]** Moreover, as discussed in detail in FIG. 4 and FIG. 5, if the data is recorded as the border area, a border close process is performed every time the recording of the data into each border area is ended. In other words, the border-in areas 106 and 116 and the border-out areas

107 and 117 are formed. If the various management information or the like is recorded in the border-in areas 106 and 116 and the border-out areas 107 and 117, the reproduction can be performed on a DVD-ROM player which can recognize the multi-border structure of the optical disc.

**[0138]** Moreover, in the above-mentioned embodiment, the optical disc 100 is explained as one example of the information recording medium, and the recorder related to the optical disc 100 is explained as one example of the information recording apparatus. The present invention, however, is not limited to the optical disc and the recorder thereof, and can be applied to other various high-density-recording or high-transmission-rate information recording media, and the recorders thereof.

**[0139]** The present invention is not limited to the above-described embodiments, and various changes may be made, if desired, without departing from the essence of the invention which can be read from the claims and the entire specification. An information recording medium, an information recording apparatus and method, and a computer program for recording control, which involve such changes, are also intended to be within the technical scope of the present invention.

#### Industrial Applicability

**[0140]** The information recording medium, the information recording apparatus and method, and the computer program of the present invention can be applied to, for example, a high-density optical disc, such as a DVD, and further to an information recording apparatus, such as a DVD recorder. Moreover, they can be applied to an information recording apparatus or the like, which is mounted on or can be connected to various computer equipment for consumer use or business use, for example.

#### Claims

1. An information recording medium (100), comprising:
  - a first recording layer (L0) and a second recording layer (L1) in which record information can be recorded,
  - the record information being recorded from inner to outer side in the first recording layer (L0) and the record information being recorded from the outer to the inner side in the second recording layer (L1), wherein
  - a plurality of recording zones (R\_Zone) are located on the information recording medium (100),
  - a layer jump interval from said first recording layer (L0) to said second recording layer (L1) defines a recording section (105a to 115f, 115a to 115f) in a recording zone (R\_Zone), wherein the recording section includes a partial recording ar-

ea (105a to 105f) of said first recording layer (L0) and a partial recording area (115a to 115f) of said second recording layer (L1) located in a position facing the partial recording area of said first recording layer, 5

in the recording section (105a to 105f, 115a to 115f), the record information is recorded from the partial recording area (105a to 105f) of the first recording layer (L0) to the partial recording area (115a to 115f) of the second recording layer (L1) in this order, 10

each of the plurality of recording zones (R\_Zone) includes a plurality of recording sections (105a to 115f, 115a to 115f), 15

in each of the recording zones (R\_Zone), the record information is recorded from the recording section (105a, 115a) which is most inner side to the recording section (105c, 115c) which is most outer side in this order, **characterized in that** 20

at least one of said first recording layer (L0) and said second recording layer (L1) comprises a size area (104, 114) to record therein size information (121) which indicates the layer jump interval, 25

a size of each of the plurality of recording sections is fixed in the corresponding recording zone, wherein a size of each of the plurality of recording sections included in a first recording zone (R\_Zone#2) out of the plurality of recording zones is different from a size of each of the plurality of recording sections included in a second recording zone (R\_Zone#3) out of the plurality of recording zones, and 30

the size information indicates the layer jump interval for each of the plurality of recording zones, thereby the size information indicates at least (i) the layer jump interval for the first recording zone (R\_Zone#2) and (ii) the layer jump interval for the second recording zone (R\_Zone#3) which is different from the layer jump interval for the first recording zone. 35 40

2. The information recording medium (100) according to claim 1, wherein a recording unit of the record information is an ECC block unit. 45
3. The information recording medium (100) according to claim 1, wherein the size area is included in a recording management area (104, 114) into which recording management information for managing recording of the record information is recorded. 50
4. An information recording apparatus (300), comprising: 55

a recording device (352) for recording record information onto an information recording medium

(100), comprising a first recording layer (L0) and a second recording layer (L1) in which the record information can be recorded, the recording device (352) recording the record information from inner to outer side in the first recording layer (L0) and recording the record information from the outer to the inner side in the second recording layer (L1), the information recording apparatus further comprising a second controlling device (354) for controlling said recording device (352) to record the record information such that a plurality of recording zones (R\_Zone) are located on the information recording medium (100), wherein a layer jump interval from said first recording layer (L0) to said second recording layer (L1) defines a recording section (105a to 115f, 115a to 115f) in a recording zone (R\_Zone), wherein the recording section includes a partial recording area (105a to 105f) of said first recording layer (L0) and a partial recording area (115a to 115f) of said second recording layer (L1) located in a position facing the partial recording area of said first recording layer, the second controlling device (354) controls said recording device (352) to record the record information such that, in the recording section (105a to 105f, 115a to 115f), the record information is recorded from the partial recording area (105a to 105f) of the first recording layer (L0) to the partial recording area (115a to 115f) of the second recording layer (L1) in this order, the second controlling device (354) controls said recording device (352) to record the record information such that each of the plurality of recording zones (R\_Zone) includes a plurality of recording sections (105a to 115f, 115a to 115f), the second controlling device (354) controls said recording device (352) to record the record information such that in each of the recording zones (R\_Zone), the record information is recorded from the recording section (105a, 115a) which is most inner side to the recording section (105c, 115c) which is most outer side in this order, **characterized in that** said information recording apparatus (300) further comprises:

a first controlling device (354) for controlling said recording device (352) to record size information (121), as the record information, which indicates the layer jump interval into at least one of said first recording layer (L0) and said second recording layer (L1); and the second controlling device (354) controls said recording device (352) to record the record information such that a size of each of the plurality of recording sections is fixed

- in the corresponding recording zone, wherein a size of each of the plurality of recording sections included in a first recording zone (R\_Zone#2) out of the plurality of recording zones is different from a size of each of the plurality of recording sections included in a second recording zone (R\_Zone#3) out of the plurality of recording zones, the size information indicates the layer jump interval for each of the plurality of recording zones, thereby the size information indicates at least (i) the layer jump interval for the first recording zone (R\_Zone#2) and (ii) the layer jump interval for the second recording zone (R\_Zone#3) which is different from the layer jump interval for the first recording zone.
5. The information recording apparatus (300) according to claim 4, wherein said recording device (352) records the record information by an ECC block unit.
  6. The information recording apparatus (300) according to claim 4, wherein said first controlling device (354) controls said recording device (352) to record the size information (121) into a recording management area (104, 114) into which recording management information for managing recording of the record information is recorded.
  7. The information recording apparatus (300) according to claim 4, further comprising a preparing device (354) for preparing control information to control at least one of recording and reproduction of the record information, on the basis of the size information (121).
  8. An information recording method, comprising:
    - a recording process (S107) of recording record information onto an information recording medium (100), comprising a first recording layer (L0) and a second recording layer (L1) in which the record information can be recorded,
    - the recording process (S107) recording the record information from inner to outer side in the first recording layer (L0) and recording the record information from the outer to the inner side in the second recording layer (L1),
    - the information recording apparatus method comprising a second controlling process (S105) for controlling said recording process (S107) to record the record information such that a plurality of recording zones (R\_Zone) are located on the information recording medium (100), wherein a layer jump interval from said first recording layer (L0) to said second recording layer (L1) de-

fines a recording section (105a to 115f, 115a to 115f) in a recording zone (R\_Zone), wherein the recording section includes a partial recording area (105a to 105f) of said first recording layer (L0) and a partial recording area (115a to 115f) of said second recording layer (L1) located in a position facing the partial recording area of said first recording layer,

the second controlling process (S107) controls said recording process (S105) to record the record information such that, in the recording section (105a to 105f, 115a to 115f), the record information is recorded from the partial recording area (105a to 105f) of the first recording layer (L0) to the partial recording area (115a to 115f) of the second recording layer (L1) in this order the second controlling process (S105) controls said recording process (S107) to record the record information such that each of the plurality of recording zones (R\_Zone) includes a plurality of recording sections (105a to 115f, 115a to 115f),

the second controlling process (S105) controls said recording process (S105) to record the record information such that in each of the recording zones (R\_Zone), the record information is recorded from the recording section (105a, 115a) which is most inner side to the recording section (105c, 115c) which is most outer side in this order,

**characterized in that** said information recording method further comprises:

- a first controlling process (S106) of controlling said recording process (S107) to record size information (121) which indicates the layer jump interval into at least one of said first recording layer (L0) and said second recording layer (L1); and
- the second controlling process (S107) controls said recording process (S105) to record the record information such that a size of each of the plurality of recording sections is fixed in the corresponding recording zone, wherein a size of each of the plurality of recording sections included in a first recording zone (R\_Zone#2) out of the plurality of recording zones is different from a size of each of the plurality of recording sections included in a second recording zone (R\_Zone#3) out of the plurality of recording zones
- the size information indicates the layer jump interval for each of the plurality of recording zones, thereby the size information indicates at least (i) the layer jump interval for the first recording zone (R\_Zone#2) and (ii) the layer jump interval for the second re-

ording zone (R\_Zone#3) which is different from the layer jump interval for the first recording zone.

## Patentansprüche

### 1. Ein Datenaufzeichnungsmedium (100), aufweisend:

- eine erste Aufzeichnungsschicht (L0) und eine zweite Aufzeichnungsschicht (L1), in welchen aufgezeichnete Daten aufgezeichnet werden können;
- wobei die aufgezeichneten Daten von einer inneren zu einer äußeren Seite in der ersten Aufzeichnungsschicht (L0) und von einer äußeren zu einer inneren Seite in der zweiten Aufzeichnungsschicht (L1) aufgezeichnet werden; wobei
- eine Mehrzahl von Aufzeichnungszonen (R\_Zone) auf dem Datenaufzeichnungsmedium (100) angeordnet ist;
- ein Schichtsprungintervall von der ersten Aufzeichnungsschicht (L0) zu der zweiten Aufzeichnungsschicht (L1) einen Aufzeichnungsbereich (105a bis 105f, 115a bis 115f) in der Aufzeichnungszone (R\_Zone) definiert, wobei der Aufzeichnungsbereich einen partiellen Aufzeichnungsbereich (105a bis 105f) der ersten Aufzeichnungsschicht (L0) und einen partiellen Aufzeichnungsbereich (115a bis 115f) der zweiten Aufzeichnungsschicht (L1) aufweist, wobei der partielle Aufzeichnungsbereich (115a bis 115f) der zweiten Aufzeichnungsschicht (L1) dem partiellen Aufzeichnungsbereich (105a bis 105f) der ersten Aufzeichnungsschicht (L0) zugewandt angeordnet ist;
- in den Aufzeichnungsbereichen (105a bis 105f, 115a bis 115f) die aufgezeichneten Daten in der Reihenfolge von dem partiellen Aufzeichnungsbereich (105a bis 105f) der ersten Aufzeichnungsschicht (L0) zu dem partiellen Aufzeichnungsbereich (115a bis 115f) der zweiten Aufzeichnungsschicht (L1) aufgezeichnet sind;
- jede der Mehrzahl von Aufzeichnungszonen (R\_Zone) eine Mehrzahl von Aufzeichnungsbereichen (105a bis 105f, 115a bis 115f) aufweist;
- in jeder der Aufzeichnungszonen (R\_Zone) die aufgezeichneten Daten von dem Aufzeichnungsbereich (105a, 115a), der die innerste Seite bildet, zu dem Aufzeichnungsbereich (105c, 115c), der in dieser Reihenfolge die äußerste Seite bildet, aufgezeichnet sind,

### dadurch gekennzeichnet, dass

- wenigstens eine von der ersten Aufzeichnungsschicht (L0) und der zweiten Aufzeichnungsschicht (L1) einen Größenbereich (104,

114) aufweist, um darin Größeninformationen (121) aufzuzeichnen, die das Schichtsprungintervall angeben;

- eine Größe von jedem der Mehrzahl von Aufzeichnungsbereichen in der korrespondierenden Aufzeichnungszone festgelegt ist, wobei die Größe von jedem der Mehrzahl von Aufzeichnungsbereichen, enthalten in einer ersten Aufzeichnungszone (R\_Zone#2) aus der Mehrzahl von Aufzeichnungszonen, unterschiedlich ist von der Größe von jedem der Mehrzahl von Aufzeichnungsbereichen, aufgezeichnet in einer zweiten Aufzeichnungszone (R\_Zone#3) aus der Mehrzahl von Aufzeichnungszonen; und
- die Größeninformationen (121) das Schichtsprungintervall für jede der Mehrzahl von Aufzeichnungszonen angeben, wobei die Größeninformationen (121) mindestens angeben:

- (i) das Schichtsprungintervall für die erste Aufzeichnungszone (R\_Zone#2); und
- (ii) das Schichtsprungintervall für die zweite Aufzeichnungszone (R\_Zone#3), das unterschiedlich von dem Schichtsprungintervall für die erste Aufzeichnungszone ist.

### 2. Das Datenaufzeichnungsmedium (100) gemäß Anspruch 1, wobei eine Aufzeichnungseinheit der aufgezeichneten Daten eine ECC-Blockeinheit ist.

### 3. Das Datenaufzeichnungsmedium (100) gemäß Anspruch 1, wobei der Größenbereich in einem Aufzeichnungsverwaltungsbereich (104, 114) aufgezeichnet ist, in dem Aufzeichnungsverwaltungsinformationen zum Verwalten des Aufzeichnens der aufgezeichneten Daten aufgezeichnet sind.

### 4. Eine Datenaufzeichnungsvorrichtung (300), aufweisend:

- eine Aufzeichnungsvorrichtung (352) zum Aufzeichnen von aufgezeichneten Daten auf einem Datenaufzeichnungsmedium (100), aufweisend eine erste Aufzeichnungsschicht (L0) und eine zweite Aufzeichnungsschicht (L1), in welchen die aufgezeichneten Daten aufgezeichnet werden können;
- die Aufzeichnungsvorrichtung (352), die aufgezeichneten Daten von der inneren zu der äußeren Seite in der ersten Aufzeichnungsschicht (L0) aufzeichnend und die aufgezeichneten Daten von der äußeren zu der inneren Seite in der zweiten Aufzeichnungsschicht (L1) aufzeichnend;
- die Datenaufzeichnungsvorrichtung (300), ferner aufweisend eine zweite Kontrollvorrichtung (354) zum Kontrollieren der Aufzeichnungsvorrichtung (352) zum Aufzeichnen der aufgezeich-

neten Daten derart, dass eine Mehrzahl von Aufzeichnungszonen (R\_Zone) auf dem Datenaufzeichnungsmedium (100) angeordnet ist, wobei

- ein Schichtsprungintervall von der ersten Aufzeichnungsschicht (L0) zu der zweiten Aufzeichnungsschicht (L1) einen Aufzeichnungsbereich (105a bis 105f, 115a bis 115f) in einer Aufzeichnungszone (R\_Zone) definiert, wobei der Aufzeichnungsbereich einen partiellen Aufzeichnungsbereich (105a bis 105f) auf der ersten Aufzeichnungsschicht (L0) und einen partiellen Aufzeichnungsbereich (115a bis 115f) auf der zweiten Aufzeichnungsschicht (L1) aufweist, wobei der partielle Aufzeichnungsbereich (115a bis 115f) auf der zweiten Aufzeichnungsschicht (L1) dem partiellen Aufzeichnungsbereich (105a bis 105f) der ersten Aufzeichnungsschicht (L0) zugewandt angeordnet ist;
- die zweite Kontrollvorrichtung (354) kontrolliert die Aufzeichnungsvorrichtung (352) zum Aufzeichnen von aufgezeichneten Daten derart, dass in dem Aufzeichnungsbereich (105a bis 105f, 115a bis 115f) die aufgezeichneten Daten in der Reihenfolge von dem partiellen Aufzeichnungsbereich (105a bis 105f) auf der ersten Aufzeichnungsschicht (L0) zu dem partiellen Aufzeichnungsbereich (115a bis 115f) auf der zweiten Aufzeichnungsschicht (L1) aufgezeichnet werden;
- die zweite Kontrollvorrichtung (354) kontrolliert die Aufzeichnungsvorrichtung (352) zum Aufzeichnen von aufgezeichneten Daten derart, dass jede der Mehrzahl von Aufzeichnungszonen (R\_Zone) eine Mehrzahl von Aufzeichnungsbereichen (105a bis 105f, 115a bis 115f) aufweist;
- die zweite Kontrollvorrichtung (354) kontrolliert die Aufzeichnungsvorrichtung (352) zum Aufzeichnen von aufgezeichneten Daten derart, dass in jeder der Aufzeichnungszonen (R\_Zone) die aufgezeichneten Daten in der Reihenfolge von dem Aufzeichnungsbereich (105a, 115a), der die innerste Seite bildet, zu dem Aufzeichnungsbereich (105c, 115c), der die äußerste Seite bildet, aufgezeichnet werden;
- **gekennzeichnet dadurch, dass** die Datenaufzeichnungsvorrichtung (300) ferner aufweist:
  - eine erste Kontrollvorrichtung (354) zum Kontrollieren der Aufzeichnungsvorrichtung (352), um Größeninformationen (121) als die aufgezeichneten Daten aufzuzeichnen, die das Schichtsprungintervall in wenigstens einer von der ersten Aufzeichnungsschicht (L0) und der zweiten Aufzeichnungsschicht (L1) angeben; und
  - die zweite Kontrollvorrichtung (354) kontrolliert die Aufzeichnungsvorrichtung (352), um aufge-

zeichnete Daten derart aufzuzeichnen, dass eine Größe von jedem der Mehrzahl von Aufzeichnungsbereichen in der korrespondierenden Aufzeichnungszone festgelegt ist, wobei die Größe von jedem der Mehrzahl von Aufzeichnungsbereichen, aufgezeichnet in einer ersten Aufzeichnungszone (R\_Zone#2) aus der Mehrzahl von Aufzeichnungszonen, unterschiedlich ist von der Größe von jedem der Mehrzahl von Aufzeichnungsbereichen, aufgezeichnet in einer zweiten Aufzeichnungszone (R\_Zone#3) aus der Mehrzahl von Aufzeichnungszonen;

- die Größeninformationen (121) das Schichtsprungintervall für jede der Mehrzahl von Aufzeichnungszonen angeben, wobei die Größeninformationen (121) mindestens angeben:

- (i) das Schichtsprungintervall für die erste Aufzeichnungszone (R\_Zone#2); und
- (ii) das Schichtsprungintervall für die zweite Aufzeichnungszone (R\_Zone#3), das unterschiedlich von dem Schichtsprungintervall für die erste Aufzeichnungszone ist.

5. Die Datenaufzeichnungsvorrichtung (300) gemäß Anspruch 4, wobei die Aufzeichnungsvorrichtung (352) die aufgezeichneten Daten mittels einer ECC-Blockeinheit aufzeichnet.
6. Die Datenaufzeichnungsvorrichtung (300) gemäß Anspruch 4, wobei die erste Kontrollvorrichtung (354) die Aufzeichnungsvorrichtung (352) zum Aufzeichnen der Größeninformationen (121) in einem Aufzeichnungsverwaltungsbereich (104, 114) kontrolliert, in dem Aufzeichnungsverwaltungsinformationen zum Verwalten des Aufzeichnens der aufgezeichneten Daten aufgezeichnet werden.
7. Die Datenaufzeichnungsvorrichtung (300) gemäß Anspruch 4, ferner aufweisend eine Vorbereitungsvorrichtung (354) zum Vorbereiten von Kontrolldaten zum Kontrollieren mindestens eines Aufzeichnens und Wiedergeben der aufgezeichneten Daten auf Grundlage der Größeninformationen (121).
8. Ein Datenaufzeichnungsverfahren, aufweisend:
  - einen Aufzeichnungsvorgang (S107) zum Aufzeichnen von aufgezeichneten Daten auf einem Datenaufzeichnungsmedium (100), aufweisend eine erste Aufzeichnungsschicht (L0) und eine zweite Aufzeichnungsschicht (L1), in welchen die aufgezeichneten Daten aufgezeichnet werden können;
  - den Aufzeichnungsvorgang (S107) zum Aufzeichnen der aufgezeichneten Daten von der inneren zu der äußeren Seite in der ersten Aufzeichnungsschicht (L0) und zum Aufzeichnen

der aufgezeichneten Daten von der äußeren zu der inneren Seite in der zweiten Aufzeichnungsschicht (L1);

- wobei das Datenaufzeichnungsverfahren aufweist einen zweiten Kontrollvorgang (S105) zum Kontrollieren des Aufzeichnungsvorgangs (S107) zum Aufzeichnen der aufgezeichneten Daten derart, dass eine Mehrzahl von Aufzeichnungszonen (R\_Zone) auf dem Datenaufzeichnungsmedium (100) angeordnet werden; wobei
- ein Schichtsprungintervall von der ersten Aufzeichnungsschicht (L0) zu der zweiten Aufzeichnungsschicht (L1) einen Aufzeichnungsbereich (105a bis 105f, 115a bis 115f) in der Aufzeichnungszone (R\_Zone) definiert, wobei der Aufzeichnungsbereich einen partiellen Aufzeichnungsbereich (105a bis 105f) auf der ersten Aufzeichnungsschicht (L0) und einen partiellen Aufzeichnungsbereich (115a bis 115f) auf der zweiten Aufzeichnungsschicht (L1) aufweist, wobei der partielle Aufzeichnungsbereich (115a bis 115f) auf der zweiten Aufzeichnungsschicht (L1) dem partiellen Aufzeichnungsbereich (105a bis 105f) der ersten Aufzeichnungsschicht (L0) zugewandt angeordnet ist;
- der zweite Kontrollvorgang (S107) kontrolliert den Aufzeichnungsvorgang (S105) zum Aufzeichnen der aufgezeichneten Daten derart, dass in den Aufzeichnungsbereichen (105a bis 105f, 115a bis 115f) die aufgezeichneten Daten in der Reihenfolge von dem partiellen Aufzeichnungsbereich (105a bis 105f) auf der ersten Aufzeichnungsschicht (L0) zu dem partiellen Aufzeichnungsbereich (115a bis 115f) auf der zweiten Aufzeichnungsschicht (L1) aufgezeichnet werden;
- der zweite Kontrollvorgang (S105) kontrolliert den Aufzeichnungsvorgang (S107) zum Aufzeichnen der aufgezeichneten Daten derart, dass jede der Mehrzahl von Aufzeichnungszonen (R\_Zone) eine Mehrzahl von Aufzeichnungsbereichen (105a bis 105f, 115a bis 115f) aufweist;
- der zweite Kontrollvorgang (S105) kontrolliert den Aufzeichnungsvorgang (S105) zum Aufzeichnen der aufgezeichneten Daten derart, dass in jeder der Aufzeichnungszonen (R\_Zone) die aufgezeichneten Daten in der Reihenfolge von dem Aufzeichnungsbereich (105a, 115a), der die innerste Seite bildet, zu dem Aufzeichnungsbereich (105c, 115c), der die äußerste Seite bildet, aufgezeichnet werden;
- **gekennzeichnet dadurch, dass** das Datenaufzeichnungsverfahren ferner aufweist:
- einen ersten Kontrollvorgang (S106) zum Kontrollieren des Aufzeichnungsvorgangs (S107) zum Aufzeichnen von Größeninformationen (121), die das Schichtsprungintervall in wenig-

stens einer von der ersten Aufzeichnungsschicht (L0) und der zweiten Aufzeichnungsschicht (L1) angeben;

- der zweite Kontrollvorgang (S107) kontrolliert den Aufzeichnungsvorgang (S105) zum Aufzeichnen der aufgezeichneten Daten derart, dass eine Größe von jedem der Mehrzahl von Aufzeichnungsbereichen in der korrespondierenden Aufzeichnungszone festgelegt ist, wobei die Größe von jedem der Mehrzahl von Aufzeichnungsbereichen, aufgezeichnet in einer ersten Aufzeichnungszone (R\_Zone#2) aus der Mehrzahl von Aufzeichnungszonen, unterschiedlich ist von der Größe von jedem der Mehrzahl von Aufzeichnungsbereichen, aufgezeichnet in einer zweiten Aufzeichnungszone (R\_Zone#3) aus der Mehrzahl von Aufzeichnungszonen;
- die Größeninformationen (121) das Schichtsprungintervall für jede der Mehrzahl von Aufzeichnungszonen angeben, wobei die Größeninformationen (121) mindestens angeben:

- (i) das Schichtsprungintervall für die erste Aufzeichnungszone (R\_Zone#2); und
- (ii) das Schichtsprungintervall für die zweite Aufzeichnungszone (R\_Zone#3), die unterschiedlich von dem Schichtsprungintervall für die erste Aufzeichnungszone ist.

## Revendications

1. Support d'enregistrement d'informations (100), comprenant :

une première couche d'enregistrement (L0) et une seconde couche d'enregistrement (L1) dans lesquelles il est possible d'enregistrer des informations d'enregistrement ;  
les informations d'enregistrement étant enregistrées à partir du côté intérieur vers le côté extérieur dans la première couche d'enregistrement (L0) et les informations d'enregistrement étant enregistrées à partir du côté extérieur vers le côté intérieur dans la seconde couche d'enregistrement (L1), dans lequel :

une pluralité de zones d'enregistrement (R\_Zone) se situent sur le support d'enregistrement d'informations (100) ;  
un intervalle de saut de couche à partir de ladite première couche d'enregistrement (L0) vers ladite seconde couche d'enregistrement (L1) définit une section d'enregistrement (105a à 115f, à 115a à 115f) dans une zone d'enregistrement (R\_Zone), dans lequel la section d'enregistrement com-

prend une zone d'enregistrement partielle (105a à 105f) de ladite première couche d'enregistrement (L0) et une zone d'enregistrement partielle (115a à 115f) de ladite seconde couche d'enregistrement (L1) située dans une position qui fait face à la zone d'enregistrement partielle de ladite première couche d'enregistrement ;

dans la section d'enregistrement (105a à 105f, 115a à 115f), les informations d'enregistrement sont enregistrées à partir de la zone d'enregistrement partielle (105a à 105f) de la première couche d'enregistrement (L0) vers la zone d'enregistrement partielle (115a à 115f) de la seconde couche d'enregistrement (L1) dans cet ordre ;

chacune de la pluralité de zones d'enregistrement (R\_Zone) comprend une pluralité de sections d'enregistrement (105a à 115f, 115a à 115f) ;

dans chacune des zones d'enregistrement (R\_Zone), les informations d'enregistrement sont enregistrées à partir de la section d'enregistrement (105a, 115a) qui se situe sur le côté le plus intérieur vers la section d'enregistrement (105c, 115c) qui se situe sur le côté le plus extérieur dans cet ordre,

**caractérisé en ce que :**

l'une au moins de ladite première couche d'enregistrement (L0) et de ladite seconde couche d'enregistrement (L1) comprend une zone de taille (104, 114) destinée à y enregistrer des informations de taille (121) qui indiquent l'intervalle de saut de couche ;

la taille de chacune de la pluralité de sections d'enregistrement est fixée dans la zone d'enregistrement correspondante, dans lequel la taille de chacune de la pluralité de sections d'enregistrement incluses dans une première zone d'enregistrement (R\_Zone#2) parmi la pluralité de zones d'enregistrement, est différente de la taille de chacune de la pluralité de sections d'enregistrement incluses dans une deuxième zone d'enregistrement (R\_Zone#3) parmi la pluralité de zones d'enregistrement ; et

les informations de taille indiquent l'intervalle de saut de couche pour chacune de la pluralité de zones d'enregistrement, les informations de taille indiquent de ce fait au moins (i) l'intervalle de saut de couche pour la première zone d'enregistrement (R\_Zone#2) et (ii) l'intervalle de saut de couche pour la

deuxième zone d'enregistrement (R\_Zone#3) qui est différent de l'intervalle de saut de couche pour la première zone d'enregistrement.

2. Support d'enregistrement d'informations (100) selon la revendication 1, dans lequel une unité d'enregistrement d'informations d'enregistrement est une unité de bloc ECC.

3. Support d'enregistrement d'informations (100) selon la revendication 1, dans lequel la zone de taille est incluse dans une zone de gestion d'enregistrement (104, 114) dans laquelle sont enregistrées des informations de gestion d'enregistrement destinées à gérer l'enregistrement des informations d'enregistrement.

4. Appareil d'enregistrement d'informations (300), comprenant :

un dispositif d'enregistrement (352) destiné à enregistrer des informations d'enregistrement sur un support d'enregistrement d'informations (100), comprenant une première couche d'enregistrement (L0) et une seconde couche d'enregistrement (L1) dans lesquelles il est possible d'enregistrer des informations d'enregistrement ;

le dispositif d'enregistrement (352) enregistrant les informations d'enregistrement à partir du côté intérieur vers le côté extérieur dans la première couche d'enregistrement (L0) et enregistrant les informations d'enregistrement à partir du côté extérieur vers le côté intérieur dans la seconde couche d'enregistrement (L1) ;

l'appareil d'enregistrement d'informations comprenant en outre un second dispositif de commande (354) destiné à commander ledit dispositif d'enregistrement (352) de façon à enregistrer les informations d'enregistrement de telle sorte qu'une pluralité de zones d'enregistrement (R\_Zone) se situent sur le support d'enregistrement d'informations (100), dans lequel :

un intervalle de saut de couche à partir de ladite première couche d'enregistrement (L0) vers ladite seconde couche d'enregistrement (L1) définit une section d'enregistrement (105a à 115f, à 115a à 115f) dans une zone d'enregistrement (R\_Zone), dans lequel la section d'enregistrement comprend une zone d'enregistrement partielle (105a à 105f) de ladite première couche d'enregistrement (L0) et une zone d'enregistrement partielle (115a à 115f) de ladite seconde couche d'enregistrement (L1) située dans une position qui fait face à la zone

d'enregistrement partielle de ladite première couche d'enregistrement ;  
 le second dispositif de commande (354) commande ledit dispositif d'enregistrement (352) de façon à enregistrer les informations d'enregistrement de telle sorte que, dans la section d'enregistrement (105a à 105f, 115a à 115f), les informations d'enregistrement soient enregistrées à partir de la zone d'enregistrement partielle (105a à 105t) de la première couche d'enregistrement (L0) vers la zone d'enregistrement partielle (115a à 115f) de la seconde couche d'enregistrement (L1) dans cet ordre ;  
 le second dispositif de commande (354) commande ledit dispositif d'enregistrement (352) de façon à enregistrer les informations d'enregistrement de telle sorte que chacune de la pluralité de zones d'enregistrement (R\_Zone) inclue une pluralité de sections d'enregistrement (105a à 115f, 115a à 115f) ;  
 le second dispositif de commande (354) commande ledit dispositif d'enregistrement (352) de façon à enregistrer les informations d'enregistrement de telle sorte que dans chacune des zones d'enregistrement (R\_Zone), les informations d'enregistrement soient enregistrées à partir de la section d'enregistrement (105a, 115a) qui se situe sur le côté le plus intérieur vers la section d'enregistrement (105c, 115c) qui se situe sur le côté le plus extérieur dans cet ordre ;

**caractérisé en ce que** ledit appareil d'enregistrement d'informations (300) comprend en outre :

un premier dispositif de commande (354) destiné à commander ledit dispositif d'enregistrement (352) de façon à enregistrer des informations de taille (121), en tant qu'informations d'enregistrement, qui indiquent l'intervalle de saut de couche dans l'une au moins de ladite première couche d'enregistrement (L0) et de ladite seconde couche d'enregistrement (L1) ; et  
 le second dispositif de commande (354) commande ledit dispositif d'enregistrement (352) de façon à enregistrer les informations d'enregistrement de telle sorte que la taille de chacune de la pluralité de sections d'enregistrement soit fixée dans la zone d'enregistrement correspondante, dans lequel la taille de chacune de la pluralité de sections d'enregistrement incluses dans une première zone d'enregistrement (R\_

Zone#2) parmi la pluralité de zones d'enregistrement, est différente de la taille de chacune de la pluralité de sections d'enregistrement incluses dans une deuxième zone d'enregistrement (R\_Zone#3) parmi la pluralité de zones d'enregistrement ;  
 les informations de taille indiquent l'intervalle de saut de couche pour chacune de la pluralité de zones d'enregistrement, les informations de taille indiquent de ce fait au moins (i) l'intervalle de saut de couche pour la première zone d'enregistrement (R\_Zone#2) et (ii) l'intervalle de saut de couche pour la deuxième zone d'enregistrement (R\_Zone#3) qui est différent de l'intervalle de saut de couche pour la première zone d'enregistrement.

5. Appareil d'enregistrement d'informations (300) selon la revendication 4, dans lequel ledit dispositif d'enregistrement (352) enregistre les informations d'enregistrement à l'aide d'une unité de bloc ECC.
6. Appareil d'enregistrement d'informations (300) selon la revendication 4, dans lequel ledit premier dispositif de commande (354) commande ledit dispositif d'enregistrement (352) de façon à enregistrer les informations de taille (121) dans une zone de gestion d'enregistrement (104, 114) dans laquelle sont enregistrées des informations de gestion d'enregistrement destinées à gérer l'enregistrement des informations d'enregistrement.
7. Appareil d'enregistrement d'informations (300) selon la revendication 4, comprenant en outre un dispositif de préparation (354) destiné à préparer des informations de commande afin de commander l'un au moins d'un enregistrement et d'une reproduction des informations d'enregistrement, sur la base des informations de taille (121).
8. Procédé d'enregistrement d'informations comprenant :

un processus d'enregistrement (S107) consistant à enregistrer des informations d'enregistrement sur un support d'enregistrement d'informations (100), comprenant une première couche d'enregistrement (L0) et une seconde couche d'enregistrement (L1) dans lesquelles il est possible d'enregistrer des informations d'enregistrement ;  
 le processus d'enregistrement (S107) enregistrant les informations d'enregistrement à partir du côté intérieur vers le côté extérieur dans la première couche d'enregistrement (L0) et enregistrant les informations d'enregistrement à partir du côté extérieur vers le côté intérieur dans

la seconde couche d'enregistrement (L1) ;  
 le procédé d'appareil d'enregistrement d'infor-  
 mations comprenant un second processus de  
 commande (S 105) consistant à commander ledit  
 processus d'enregistrement (S107) de façon  
 à enregistrer les informations d'enregistrement  
 de telle sorte qu'une pluralité de zones d'enre-  
 gistrement (R\_Zone) se situent sur le support  
 d'enregistrement d'informations (100), dans  
 lequel :

un intervalle de saut de couche à partir de  
 ladite première couche d'enregistrement  
 (L0) vers ladite seconde couche d'enregistre-  
 ment (L1) définit une section d'enregistre-  
 ment (105a à 115f, à 115a à 115f) dans  
 une zone d'enregistrement (R\_Zone), dans  
 lequel la section d'enregistrement compre-  
 nd une zone d'enregistrement partielle  
 (105a à 105f) de ladite première couche  
 d'enregistrement (L0) et une zone d'enre-  
 gistrement partielle (115a à 115f) de ladite  
 seconde couche d'enregistrement (L1) si-  
 tuée dans une position qui fait face à la zone  
 d'enregistrement partielle de ladite premiè-  
 re couche d'enregistrement ;

le second processus de commande (S107)  
 commande ledit processus d'enregistre-  
 ment (S105) de façon à enregistrer les in-  
 formations d'enregistrement de telle sorte  
 que, dans la section d'enregistrement (105a  
 à 105f, 115a à 115f), les informations d'en-  
 registrement soient enregistrées à partir de  
 la zone d'enregistrement partielle (105a à  
 105f) de la première couche d'enregistre-  
 ment (L0) vers la zone d'enregistrement  
 partielle (115a à 115f) de la seconde couche  
 d'enregistrement (L1) dans cet ordre ;

le second processus de commande (S 105)  
 commande ledit processus d'enregistre-  
 ment (S107) de façon à enregistrer les in-  
 formations d'enregistrement de telle sorte  
 que chacune de la pluralité de zones d'en-  
 registrement (R\_Zone) inclue une pluralité  
 de sections d'enregistrement (105a à 115f,  
 115a à 115f) ;

le second processus de commande (S105)  
 commande ledit processus d'enregistre-  
 ment (S105) de façon à enregistrer les in-  
 formations d'enregistrement de telle sorte  
 que dans chacune des zones d'enregistre-  
 ment (R\_Zone), les informations d'enregis-  
 tement soient enregistrées à partir de la  
 section d'enregistrement (105a, 115a) qui  
 se situe sur le côté le plus intérieur vers la  
 section d'enregistrement (105c, 115c) qui  
 se situe sur le côté le plus extérieur dans  
 cet ordre ;

**caractérisé en ce que** ledit procédé d'enregis-  
 tement d'informations comprend en outre :

un premier processus de commande (S  
 106) destiné à commander ledit processus  
 d'enregistrement (S107) de façon à enre-  
 gistrer des informations de taille (121) qui  
 indiquent l'intervalle de saut de couche  
 dans l'une au moins de ladite première cou-  
 che d'enregistrement (L0) et de ladite se-  
 conde couche d'enregistrement (L1) ; et  
 le second processus de commande (S 107)  
 commande ledit processus d'enregistre-  
 ment (S105) de façon à enregistrer les in-  
 formations d'enregistrement de telle sorte  
 que la taille de chacune de la pluralité de  
 sections d'enregistrement soit fixée dans la  
 zone d'enregistrement correspondante ;  
 dans lequel la taille de chacune de la plu-  
 ralité de sections d'enregistrement incluses  
 dans une première zone d'enregistrement  
 (R\_Zone#2) parmi la pluralité de zones  
 d'enregistrement est différente de la taille  
 de chacune de la pluralité de sections d'en-  
 registrement incluses dans une deuxième  
 zone d'enregistrement (R\_Zone#3) parmi  
 la pluralité de zones d'enregistrement ;  
 les informations de taille indiquent l'interval-  
 le de saut de couche pour chacune de la  
 pluralité de zones d'enregistrement, les in-  
 formations de taille indiquent de ce fait au  
 moins (i) l'intervalle de saut de couche pour  
 la première zone d'enregistrement (R\_Zo-  
 ne#2) et (ii) l'intervalle de saut de couche  
 pour la deuxième zone d'enregistrement  
 (R\_Zone#3) qui est différent de l'intervalle  
 de saut de couche pour la première zone  
 d'enregistrement.

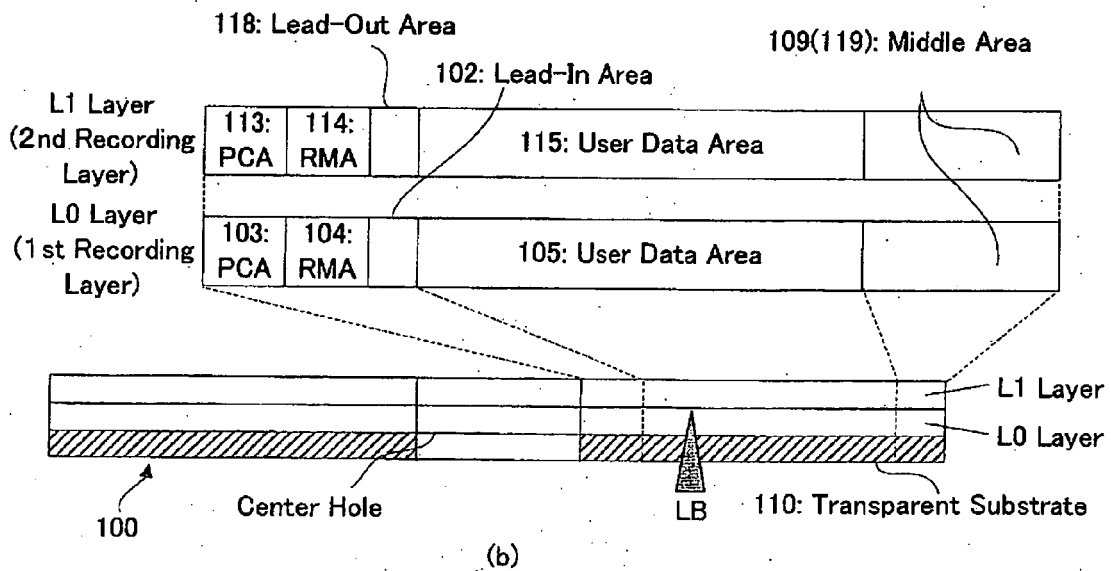
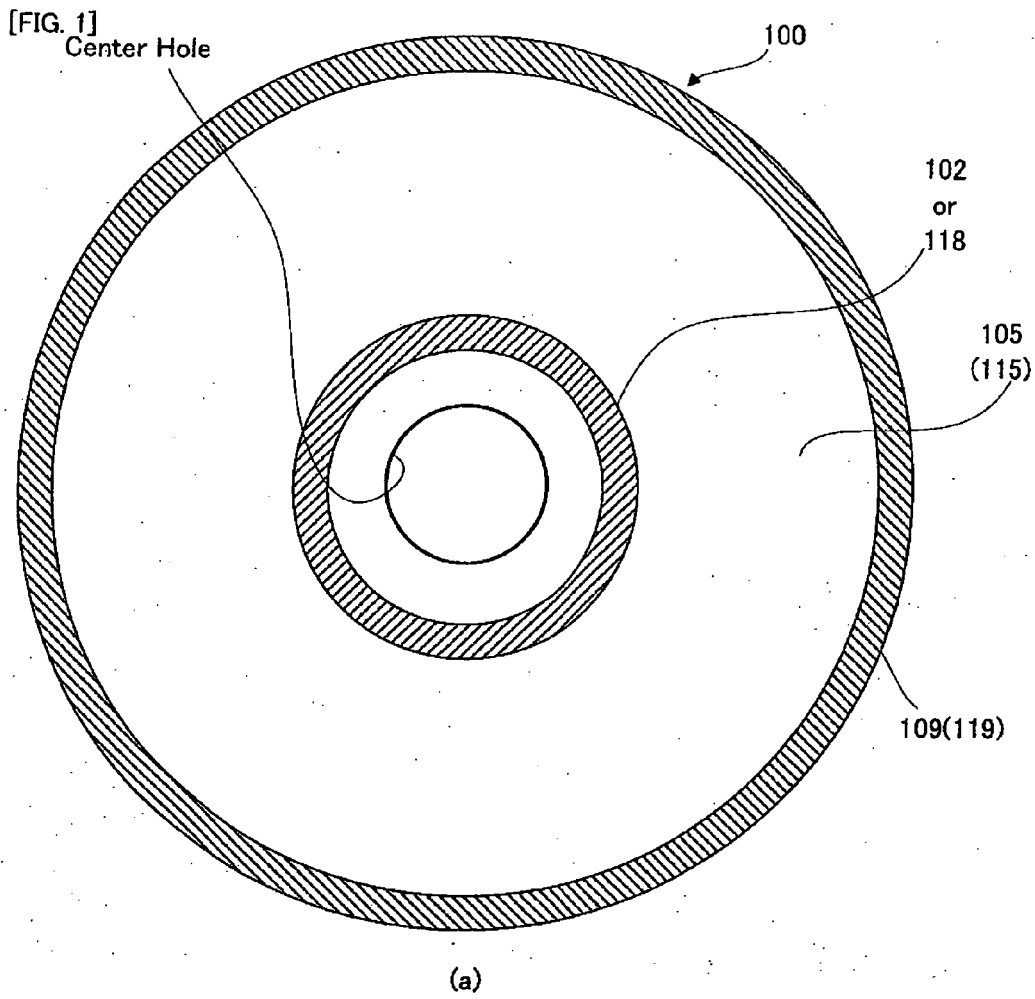

[FIG. 2]

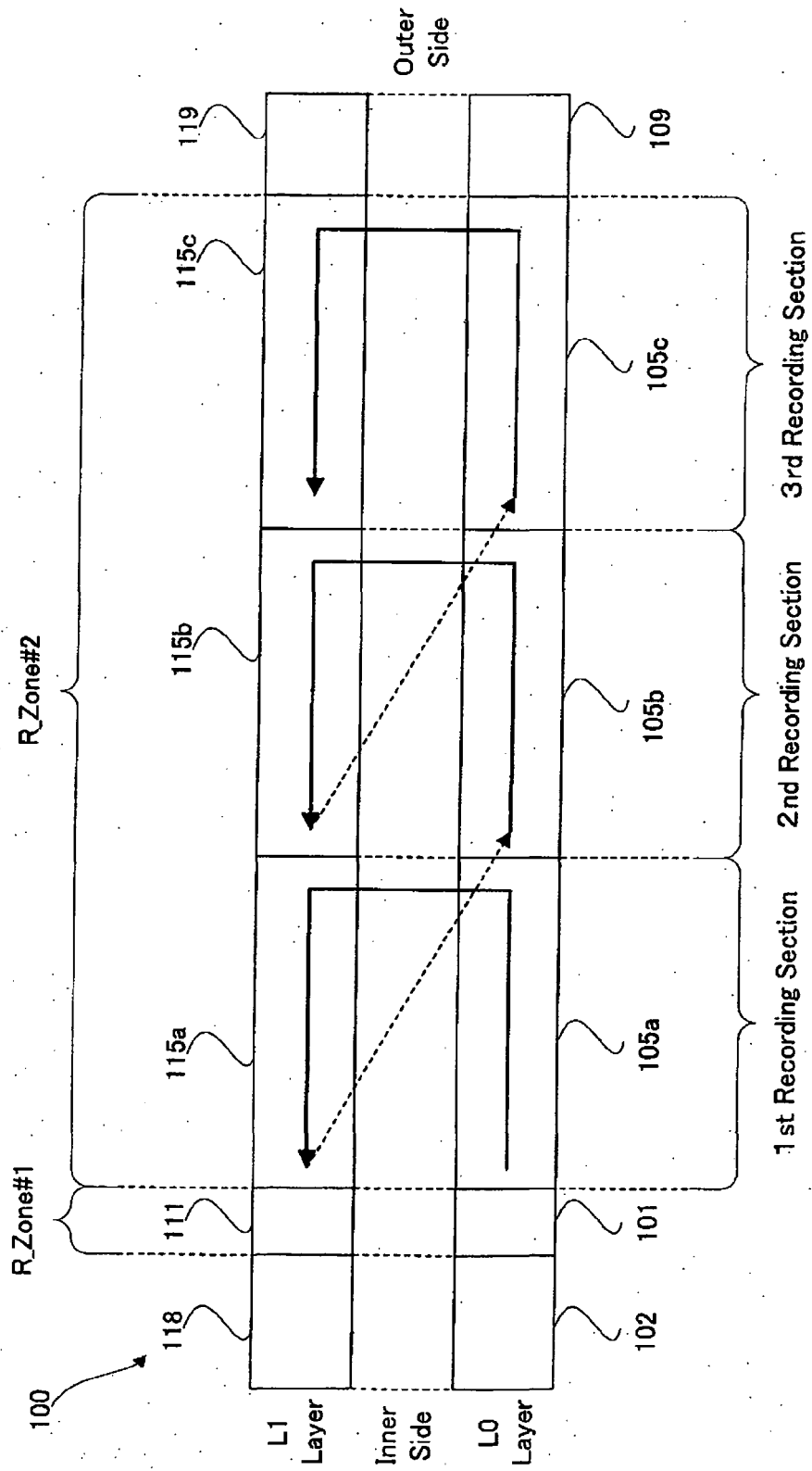

[FIG. 3]

Byte Position	Content	Size
0 to 1	Invisible R__Zone Number	2 Byte
2 to 3	1st Open R__Zone Number	2 Byte
4 to 5	2nd Open R__Zone Number	2 Byte
6 to 13	Reserved	10 Byte
14 to 15	Layer Jump Interval	2 Byte
16 to 19	Start Sector Number (R__Zone#1)	4 Byte
20 to 23	Layer Jump Address(R__Zone#1)	4 Byte
24 to 27	End Sector Number (R__Zone#1)	4 Byte
28 to 31	Last Recorded Address (R__Zone#1)	4 Byte
32 to 35	Start Sector Number (R__Zone#2)	4 Byte
.	.	4 Byte
.	.	4 Byte

121

[FIG. 4]

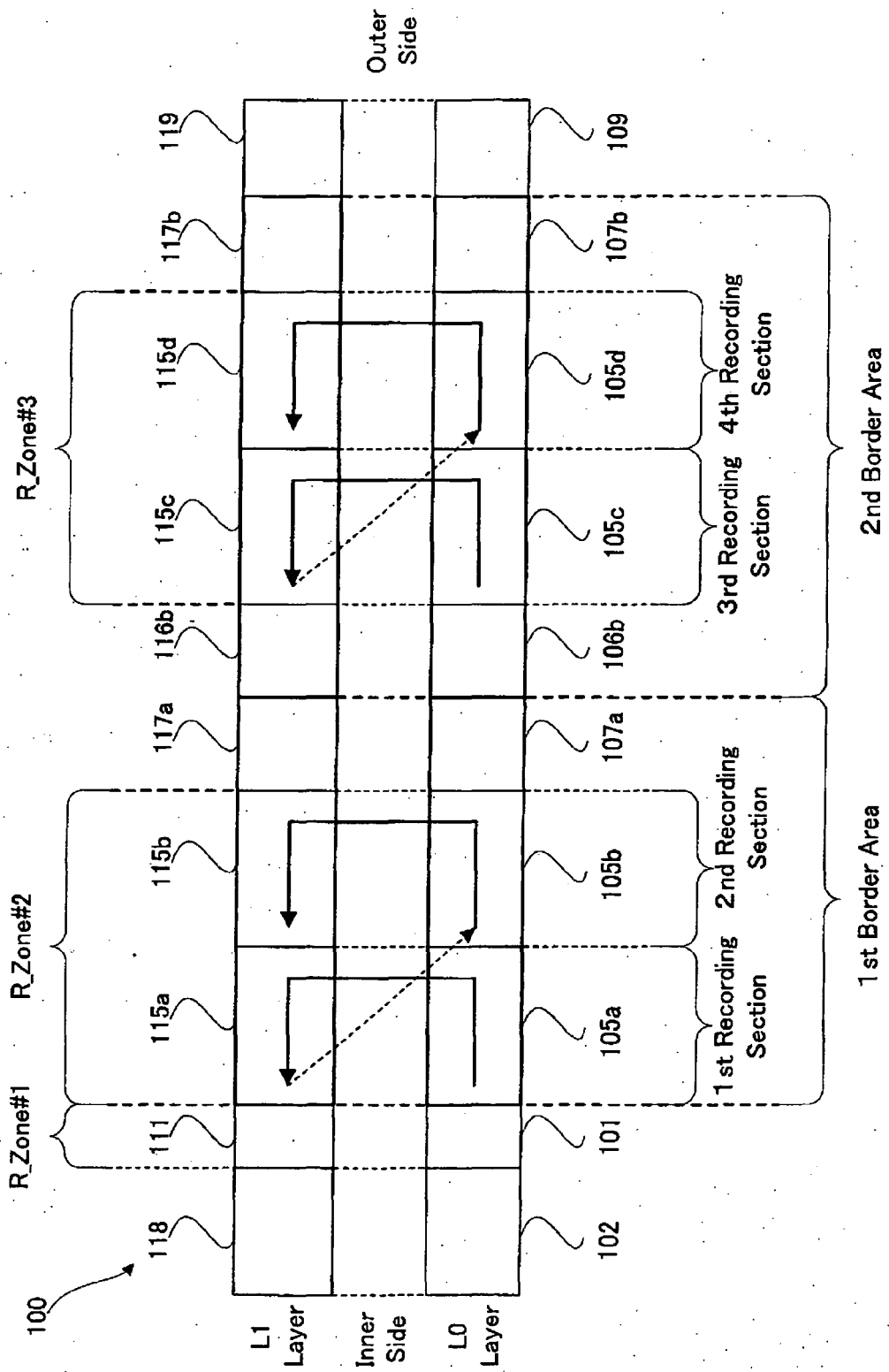



[FIG. 6]

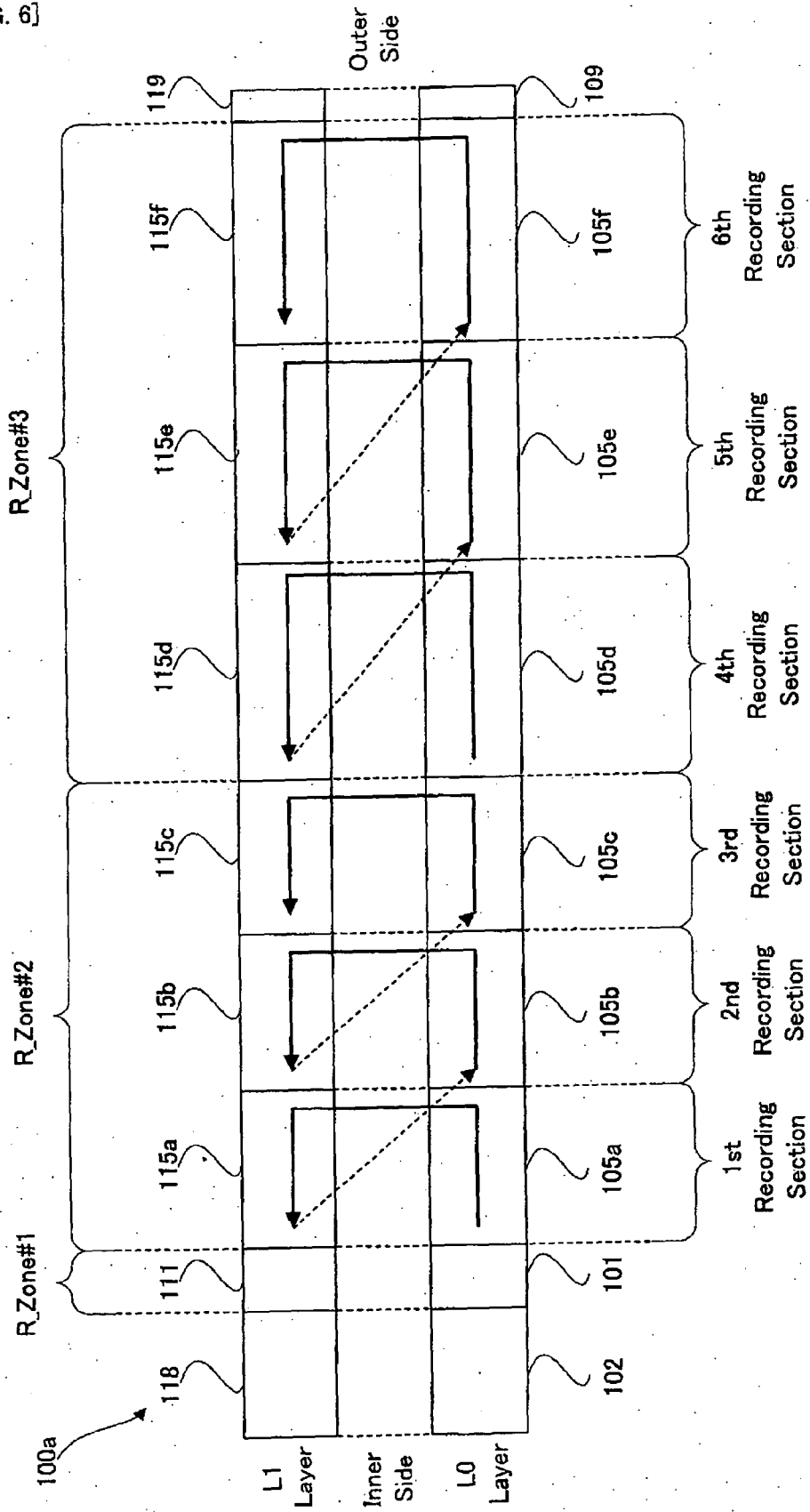

[FIG. 7]

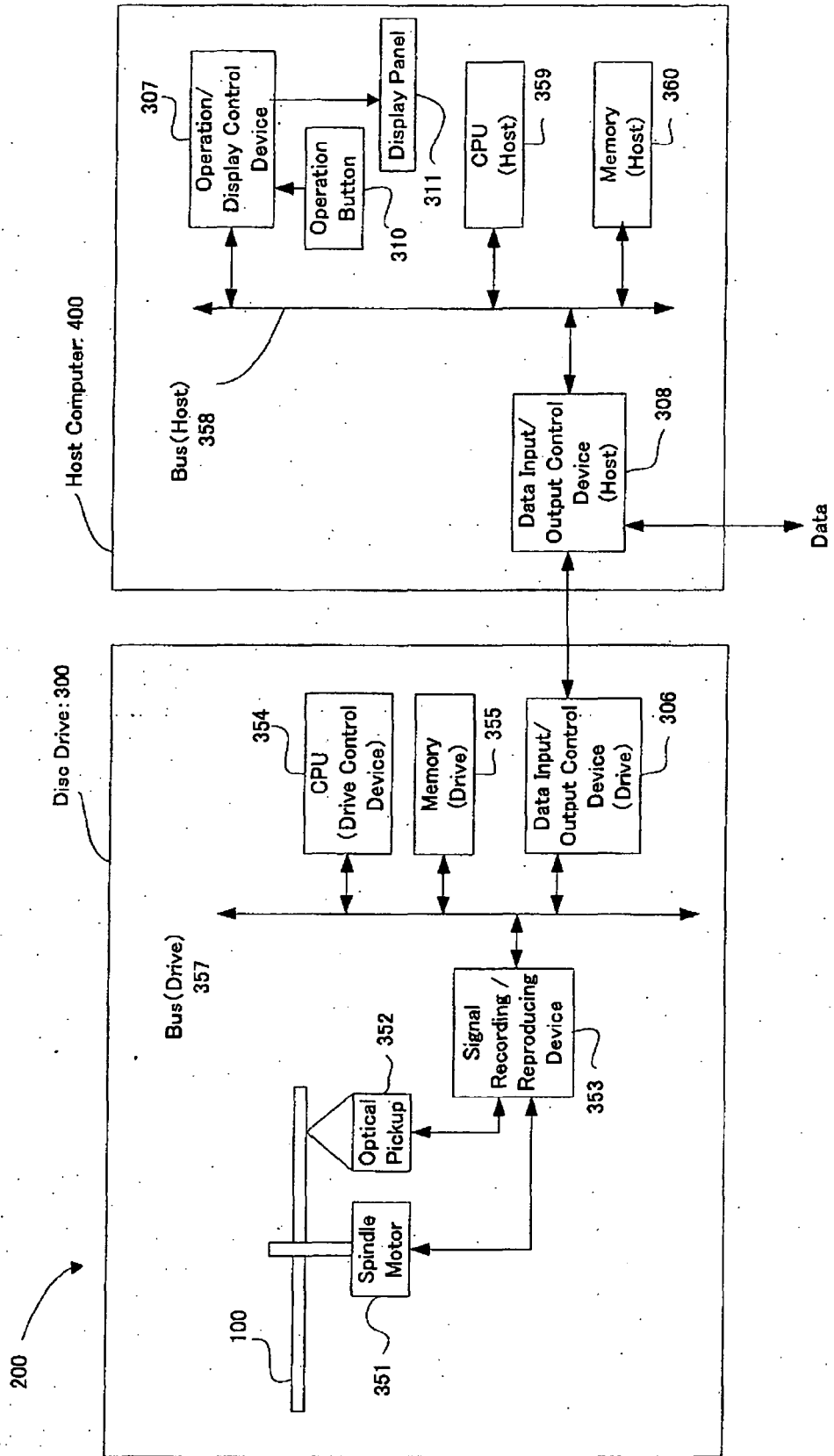

[FIG. 8]

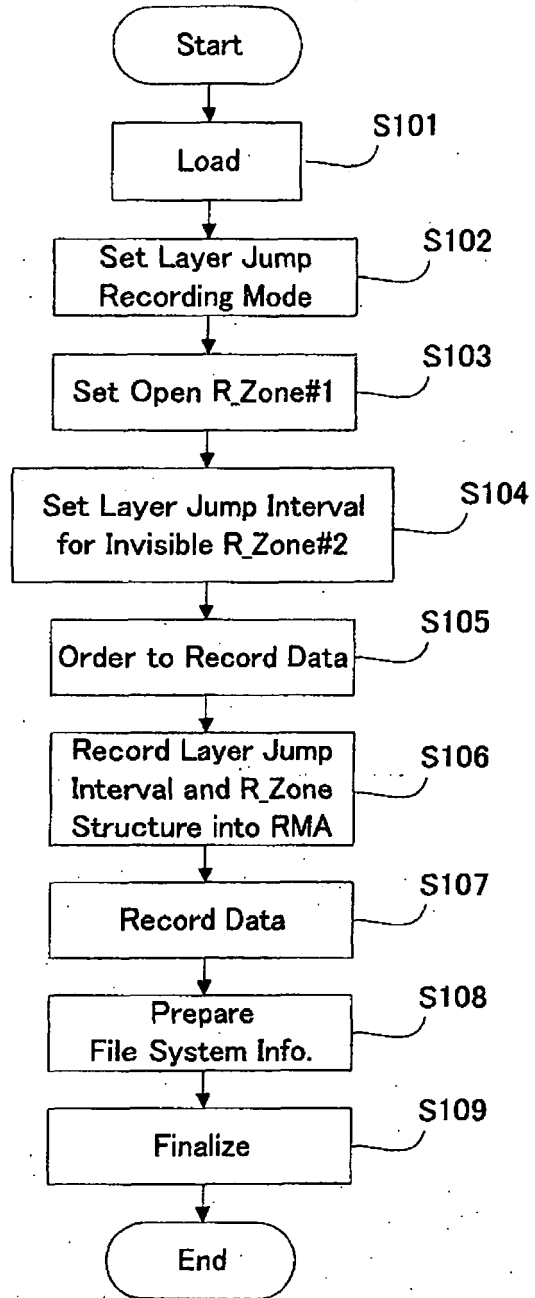

[FIG. 9]

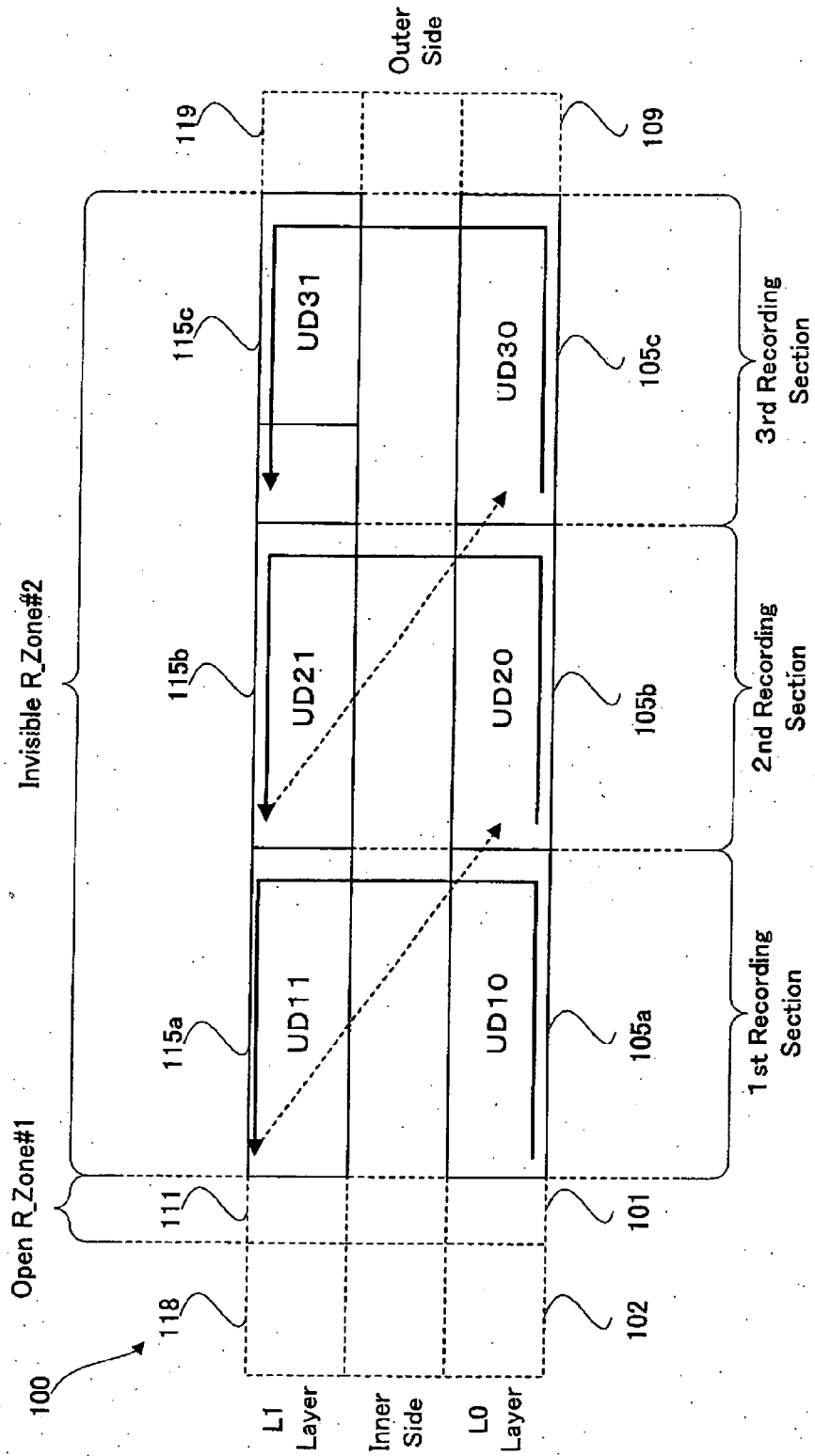

[FIG. 10]

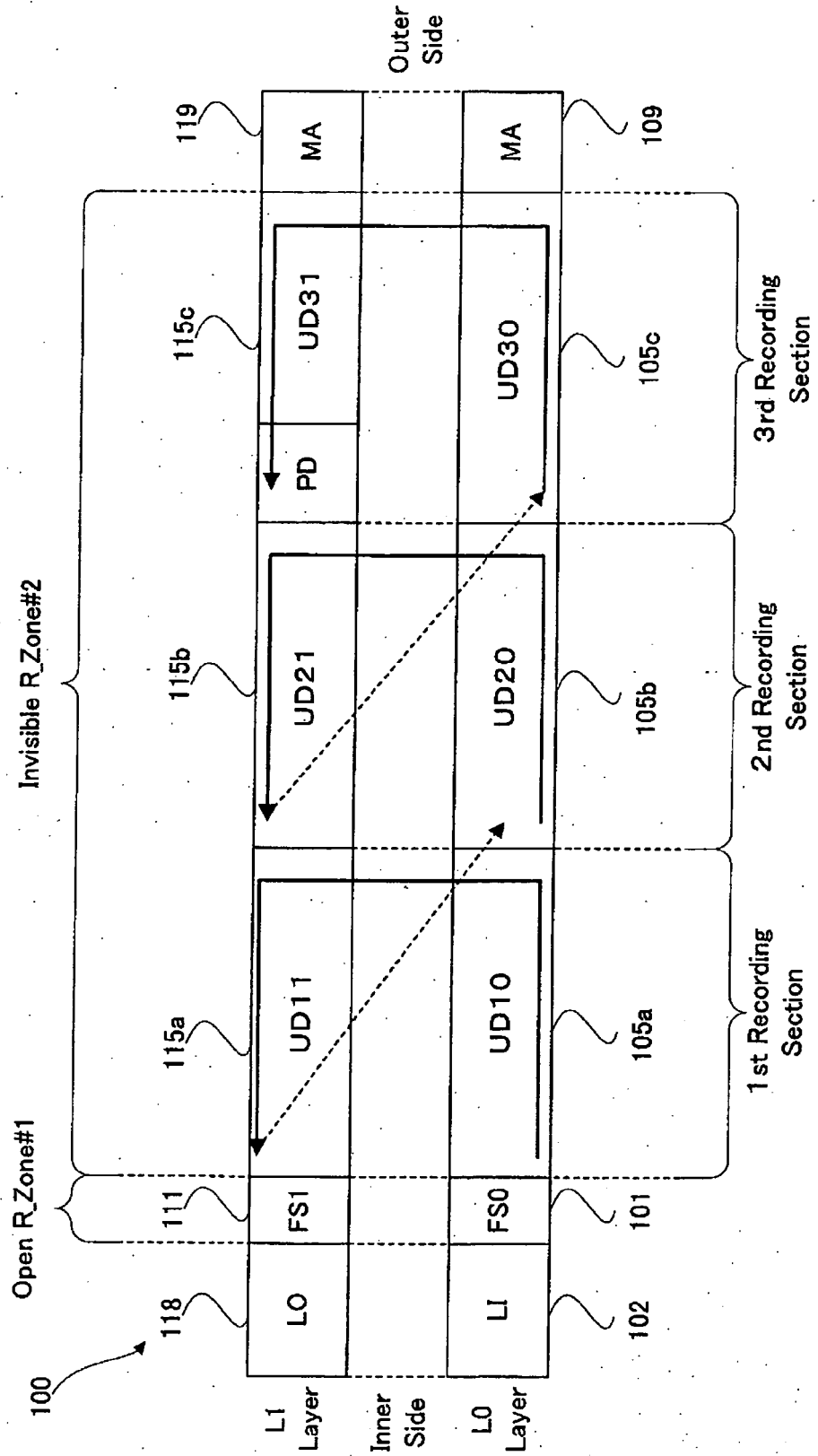

**REFERENCES CITED IN THE DESCRIPTION**

*This list of references cited by the applicant is for the reader's convenience only. It does not form part of the European patent document. Even though great care has been taken in compiling the references, errors or omissions cannot be excluded and the EPO disclaims all liability in this regard.*

**Patent documents cited in the description**

- JP 2002352469 A [0003]
- US 2004156294 A1 [0004]