



(11) **EP 1 806 463 B1**

(12) **EUROPEAN PATENT SPECIFICATION**

(45) Date of publication and mention of the grant of the patent:  
**11.11.2009 Bulletin 2009/46**

(51) Int Cl.:  
**E04H 4/14 (2006.01)**

(21) Application number: **06114828.4**

(22) Date of filing: **01.06.2006**

(54) **Traction system of mobile walls for swimming pools**

Traktionssystem für bewegliche Wände von Schwimmbecken

Système de traction des parois mobiles pour des piscines

(84) Designated Contracting States:  
**AT BE BG CH CY CZ DE DK EE ES FI FR GB GR HU IE IS IT LI LT LU LV MC NL PL PT RO SE SI SK TR**

(30) Priority: **04.01.2006 IT MI20060009**

(43) Date of publication of application:  
**11.07.2007 Bulletin 2007/28**

(73) Proprietor: **A & T Europe S.p.A.**  
**46043 Castiglione delle Stiviere (Mantova) (IT)**

(72) Inventor: **Colletto, Giorgio**  
**26013, Crema (Cremona) (IT)**

(74) Representative: **De Gregori, Antonella et al**  
**Ing. Barzano' & Zanardo Milano S.p.A.**  
**Via Borgonuovo 10**  
**20121 Milano (IT)**

(56) References cited:  
**EP-A- 1 288 396 US-A- 3 582 999**  
**US-A1- 2002 084 213**

**EP 1 806 463 B1**

Note: Within nine months of the publication of the mention of the grant of the European patent in the European Patent Bulletin, any person may give notice to the European Patent Office of opposition to that patent, in accordance with the Implementing Regulations. Notice of opposition shall not be deemed to have been filed until the opposition fee has been paid. (Art. 99(1) European Patent Convention).

## Description

**[0001]** The present invention relates to a mobile wall traction device for swimming pools.

**[0002]** In order to organise different activities in a same swimming pool at the same time, the swimming pool sector uses mobile walls, also referred to as moveable bridges.

**[0003]** In this manner it is easy to obtain two separate areas from a single large pool for competitive sport, recreation activities and swimming lessons.

**[0004]** Normally, said mobile wall is composed of a structure in stainless steel or composite materials then coated with a grid made from a plastic such as ABS for example.

**[0005]** However, other solutions are possible, such as using exclusively fibreglass, for example, or other materials.

**[0006]** Furthermore the mobile wall can be equipped with other accessories such as hand rails for swimmers, attachment fixtures for lane-marker floating ropes, and fixed or removable starting blocks.

**[0007]** The wall must be able to move in a traverse manner, such as along the longest sides of a rectangular swimming pool for example, for positioning in the desired points. Traverse translation is normally performed by means of wheels, whose axes are fixedly mounted to the sides of the walls. Such wheels move along two parallel rails located in proximity to the longer sides of the pool, or other two opposite sides, in the case of square pools. Generally two people are required to move the wall, one at each end of the wall. Moving speed is approximately a few metres per minute.

**[0008]** In fact, mobile walls are objects with a very large surface in contact with water that creates considerable resistance to any moving action.

**[0009]** The document EP 1 288 326 describes a mobile wall traction system, whereby the mobile wall is moved by means of a gear.

**[0010]** Moreover, according to the laws of hydrodynamics, this resistance increases with the square of translation speed, and therefore a small increase in speed requires considerable applied strength. Automatic traction devices have been proposed to resolve the aforesaid problems. However, project design of a mobile wall for swimming pool for non-manual movement has always caused numerous problems due to technical standards, for example in relation to the need for safety low voltage electrical or pneumatic installations in the areas in the vicinity of the pool, as well as generally due to the need for connecting possible actuators to an energy source without interfering with the pool itself, the pool perimeter, and any activities being performed by pool users and service personnel.

**[0011]** In the light of the aforesaid problems, it is obvious that a traction system for swimming pool mobile walls is necessary, with a less tiring and more user-friendly system for translation, but that at the same time, that

does not have bulky components which occupy space destined for pool users and service personnel.

**[0012]** The aim of the present invention therefore, is to resolve the problems described above and in particular to provide a traction system for swimming pool mobile walls that makes transfer of the wall itself, easier and less tiring compared to manual systems.

**[0013]** Another aim of the present invention is to provide a swimming pool mobile wall traction system that does not include bulky components that occupy space intended for pool users and service personnel, as occurred with non-manual systems.

**[0014]** Yet another aim of the present invention is to provide a traction system for swimming pool mobile walls that is easy and intuitive to use, and at the same time extremely safe for service personnel.

**[0015]** Lastly, a further aim of the present invention is to provide a traction system for swimming pool mobile walls that is particularly simple, functional and relatively economical.

**[0016]** These and other aims according to the present invention are achieved by providing a traction system for swimming pool mobile walls as set forth in claim 1.

**[0017]** Further characteristics of the device are the subject of the dependent claims.

**[0018]** The characteristics and advantages of a traction device for swimming pool mobile walls according to the present invention will be made more clear in the following description provided as an example but by no means limiting, with reference to the appended schematic drawings wherein:

- figure 1 is a schematic plan view of a swimming pool equipped with the traction system for mobile walls according to the present invention;
- figure 2 is a schematic view of a detail of the traction system for mobile walls according to the present invention; and
- figure 3 is a schematic view of the transmission element according to the present invention, installed in a side compartment of a mobile wall.

**[0019]** In reference to the figures, a traction system for swimming pool mobile walls is shown, identified throughout by the numeral 1.

**[0020]** The traction system 1 for mobile walls for a swimming pool 4, according to the present invention can be applied to pools equipped with at least one mobile wall 2 and at least two parallel rail elements 3, located on at least two opposite sides of the pool 4.

**[0021]** The wall 2 travels along the rail elements 3 by means of magnetic coupling travel means 5.

**[0022]** Advantageously, according to the present invention, the magnetic coupling travel means 5 comprises at least one transmission element 8 for each rail element 3, which is moved by specific driving means 10, and at least one drawn element 9, attached to the mobile wall 2.

**[0023]** The drawn element 9 is functionally and mag-

netically coupled with the transmission element 8 in order to travel in unison with the latter 8.

[0024] In other words, the travelling action of the transmission element 8 along the rail element 3 generates the traction of the drawn element 9, and consequently of the mobile wall 2 attached thereto.

[0025] The transmission element 8 and the drawn element 9 are coupled together magnetically, as described previously, in a manner to permit release at the rail element 3.

[0026] Both the transmission element 8 and the drawn element 9, for their mutual magnetic coupling, comprise at least one magnet 21, in particular, either a permanent magnet or an electromagnet.

[0027] Since the rail element 3 does not interfere with the coupling between the transmission element 8 and the drawn element 9, each rail element 3 comprises at least one amagnetic tube 13, made from stainless steel for example.

[0028] The amagnetic tube 13 is equipped with an upper face 14 and is installed with the upper face 14 substantially flush with the floor paving around the perimeter 33 of the pool 4.

[0029] In addition, the transmission element 8 also comprises at least one support frame 17 for the magnet and at least two wheels 23, in particular, four in the preferred embodiment shown in figures 2 and 3.

[0030] The transmission element 8 is positioned so it will slide inside the amagnetic tube 13 in a manner so that the magnet 21 faces the upper face 14 of the tube 13.

[0031] The four wheels 23 permit the transmission element 8 to slide inside the amagnetic tube 13, activated by the driving means 10.

[0032] The positioning of the transmission element 8 and the rail element 3 is conceived so that no components occupy the space destined for pool users and service personnel.

[0033] Correspondingly, also the drawn element 9 that moves the mobile wall 2, comprises a support frame 18 for the magnet 21, and four wheels 22.

[0034] The support frame 18 supports the magnet 21 in a manner so that it faces the upper face 14 of tube 13, and consequently of the magnet 21 of the transmission element 8.

[0035] The four wheels 22 permit element 9 to slide along the external paving 33 of the pool in unison with the transmission element 8.

[0036] As shown in figure 3, the drawn element 9 is installed inside the structure of the mobile wall 2 so that it is fixed and protected by the latter. In this case as well, since there are no protruding parts, there are no elements that can disturb users or service personnel of the pool 4.

[0037] Furthermore, it should be noted that the wall 2 can be released from the transmission element 8, for maintenance purposes for example, through the application of electromagnets with invertible polarisation, or by adopting mechanical spacing systems for the electromagnets.

[0038] Known driving means are used to move the transmission element 8, and consequently the drawn element 9 and wall 2. However, in any case all moving equipment (driving means 10) are contained inside the amagnetic tube 13 at one or both ends of the pipe and/or in specific compartments set under the paving floor around the perimeter 33 of the pool. In this manner, no components occupy the spaces destined for pool users and service personnel.

[0039] In particular according to a first embodiment, the driving means 10 comprise a belt and pulley system, or cable and winch system driven by specific and known motorised means. The belt and pulley system, like the motorised means, are positioned inside the tube 13 and/or in at least one compartment located under the floor paving of the pool 4 perimeter.

[0040] Alternatively, the driving means 10 could be formed by a rack system positioned inside the tube 13, as well as a motorised means, also positioned in the tube 13 and/or in a compartment located under the floor paving of the pool 4 perimeter 33.

[0041] According to another alternative aspect of the present invention, the driving means 10 could comprise at least one oleodynamic cylinder, once again positioned in the tube 13 and/or in at least one compartment located under the floor paving of said pool 4 perimeter.

[0042] The characteristics of the traction system for mobile walls according to the present invention have been made clear from the description above, just as the relative advantages have also been made clear, and these include the following:

- reduced fatigue in moving the mobile wall in comparison to manual systems;
- elimination of components that occupy space destined for pool users and service personnel;
- safety protection for users and service personnel;
- intuitive, easy manoeuvrability;
- functional and constructive simplicity;
- relatively cheap realisation costs.

### Claims

1. Mobile wall traction system (1) for swimming pools (4) equipped with at least one mobile wall (2) and at least two parallel rail elements (3), located on at least two opposite sides of the swimming pool (4), the wall (2) being able to travel along said rail elements (3), **characterised in that** it comprises magnetic coupling travel means (5) of said mobile wall (2).
2. Traction system (1) according to claim 1 **characterised in that** the magnetic coupling travel means (5) comprise at least one transmission element (8) for each rail element (3), that travels thanks to driving means (10), and at least one drawn element (9), fixed to said mobile wall (2), and coupled

- functionally and magnetically to said transmission element (8) in order to travel in unison with said transmission element (8).
3. Traction system (1) according to claim 2 **characterised in that** said at least one transmission element (8), moved by said driving means (10) and said at least one drawn element (9) are coupled magnetically in a manner for release.
  4. Traction system (1) according to claim 2 **characterised in that** said at least one transmission element (8), and said at least one drawn element (9) comprise at least one magnet (21).
  5. Traction system (1) according to claim 4 **characterised in that** said magnet (21) is a permanent magnet and/or an electromagnet.
  6. Traction system (1) according to claim 5 **characterised in that** each of said rail elements (3) comprises at least one amagnetic tube (13) comprising an upper flat face (14), said amagnetic tube (13) being installed with said upper face (14) substantially flush with the floor paving around the perimeter of said pool (4).
  7. Traction system (1) according to claim 6, **characterised in that** said transmission element (8) also comprises at least one support frame (17) for said magnet (21) and at least two wheels (23) to permit the sliding action of said transmission element (8) inside said amagnetic tube (13).
  8. Traction system (1) according to claim 3, **characterised in that** said drawn element (9) also comprises at least one support frame for said magnet (21) and at least two wheels (22) in order to slide along the external paving (33) of said pool (4) in unison with said transmission element (8).
  9. Traction system (1) according to claim 2, **characterised in that** said drawn element (9) is installed inside the structure of said mobile wall (2) in order to be fixed to said wall (2).
  10. Traction system (1) according to claim 6, **characterised in that** said driving means (10) comprise a belt and pulley system, or cable and winch system positioned inside said tube (13) and/or in at least one compartment located under the floor paving of said pool (4) perimeter.
  11. Traction system (1) according to claim 6, **characterised in that** said driving means comprise a rack positioned inside said tube and/or in at least one compartment located under the floor paving of said pool perimeter.

12. Traction system (1) according to claim 6, **characterised in that** said driving means (10) comprise an oleodynamic cylinder positioned inside said tube (13) and/or in at least one compartment located under the floor paving of said pool (4) perimeter.

#### Patentansprüche

1. Antriebssystem (1) für bewegliche Wände für Schwimmbecken (4), welche mit mindestens einer beweglichen Wand (2) und mindestens zwei parallelen Schienenelementen (3), die an mindestens zwei gegenüberliegenden Seiten des Schwimmbeckens (4) angeordnet sind, ausgestattet sind, wobei die Wand (2) in der Lage ist, sich entlang der Schienenelemente (3) zu bewegen, **dadurch gekennzeichnet, dass** es magnetische Koppelbewegungselemente (5) der beweglichen Wand (2) umfasst.
2. Antriebssystem (1) nach Anspruch 1, **dadurch gekennzeichnet, dass** die magnetischen Koppelbewegungsmittel (5) mindestens ein Übertragungselement (8) für jedes Schienenelement (3), welches sich aufgrund eines Antriebsmittels (10) bewegt, und mindestens ein Zugelement (9), welches an der beweglichen Wand (2) befestigt ist und funktional und magnetisch mit dem Übertragungselement (8) gekoppelt ist, um sich in Übereinstimmung mit dem Übertragungselement (8) zu bewegen, umfasst.
3. Antriebssystem (1) nach Anspruch 2, **dadurch gekennzeichnet, dass** das mindestens ein Übertragungselement (8), welches von dem Antriebsmittel (10) bewegt wird und das mindestens eine Zugelement (9) in einer Art und Weise für eine Freigabe magnetisch gekoppelt sind.
4. Antriebssystem (1) nach Anspruch 2, **dadurch gekennzeichnet, dass** das mindestens eine Übertragungselement (8) und das mindestens eine Zugelement (9) mindestens einen Magneten (21) umfassen.
5. Antriebssystem (1) nach Anspruch 4, **dadurch gekennzeichnet, dass** der Magnet (21) ein Permanentmagnet und/oder ein Elektromagnet ist.
6. Antriebssystem (1) nach Anspruch 5, **dadurch gekennzeichnet, dass** jedes der Schienenelemente (3) mindestens ein amagnetisches Rohr (13) umfasst, welches eine obere flache Fläche (14) umfasst, wobei das amagnetische Rohr (13) mit der oberen Fläche (14) im Wesentlichen bündig zu dem Bodenbelag um den Beckenumfang (4) installiert ist.
7. Antriebssystem (1) nach Anspruch 6, **dadurch gekennzeichnet, dass** das Übertragungselement (8)

ferner mindestens einen Halterahmen (17) für den Magneten (21) und mindestens zwei Räder (23), um den Gleitvorgang der Übertragungselemente (8) innerhalb des amagnetischen Rohrs (13) zu ermöglichen, umfasst.

8. Antriebssystem (1) nach Anspruch 3, **dadurch gekennzeichnet, dass** das Zugelement (9) ferner mindestens einen Halterahmen für den Magneten (21) und mindestens zwei Räder (22) umfasst, um entlang dem äußeren Belag (33) des Beckens (4) in Übereinstimmung mit dem Übertragungselement (8) zu gleiten.
9. Antriebssystem (1) nach Anspruch 2, **dadurch gekennzeichnet, dass** das Zugelement (9) innerhalb der Struktur der beweglichen Wand (2) installiert ist, um an der Wand (2) befestigt zu werden.
10. Antriebssystem (1) nach Anspruch 6, **dadurch gekennzeichnet, dass** das Antriebsmittel (10) ein Riemen- und Rollensystem oder ein Seil- und Windensystem umfasst, welches in dem Rohr (13) und/oder in mindestens einem Fach, welches unter dem Bodenbelag des Beckenumfangs (4) angeordnet ist, angeordnet ist.
11. Antriebssystem (1) nach Anspruch 6, **dadurch gekennzeichnet, dass** das Antriebsmittel eine Halterung umfasst, welche in dem Rohr und/oder in mindestens einem Fach angeordnet ist, welches unter dem Bodenbelag des Beckenumfangs angeordnet ist.
12. Antriebssystem (1) nach Anspruch 6, **dadurch gekennzeichnet, dass** das Antriebsmittel (10) einen öldynamischen Zylinder umfasst, welcher in dem Rohr (13) und/oder in mindestens einem Fach, welches unter dem Bodenbelag des Beckenumfangs (4) angeordnet ist, angeordnet ist.

## Revendications

1. Système de traction de paroi mobile (1) pour des piscines (4) équipées d'au moins une paroi mobile (2) et au moins deux éléments de rail parallèles (3), situés sur au moins deux côtés opposés de la piscine (4), la paroi (2) étant capable de se déplacer le long desdits éléments de rail (3), **caractérisé en ce qu'**il comprend des moyens de déplacement à accouplement magnétique (5) de ladite paroi mobile (2).
2. Système de traction (1) selon la revendication 1, **caractérisé en ce que** les moyens de déplacement à accouplement magnétique (5) comprennent au moins un élément de transmission (8) pour chaque élément de rail (3), qui se déplace grâce à des

moyens d'entraînement (10), et au moins un élément tiré (9), fixé à ladite paroi mobile (2), et accouplé de façon fonctionnelle et magnétique audit élément de transmission (8) afin de se déplacer en tandem avec ledit élément de transmission (8).

5

10

15

20

25

30

35

40

45

50

55

3. Système de traction (1) selon la revendication 2, **caractérisé en ce que** ledit au moins un élément de transmission (8), déplacé par lesdits moyens d'entraînement (10), et ledit au moins un élément tiré (9) sont accouplés magnétiquement d'une manière à se libérer.

4. Système de traction (1) selon la revendication 2, **caractérisé en ce que** ledit au moins un élément de transmission (8), et ledit au moins un élément tiré (9) comprennent au moins un aimant (21).

5. Système de traction (1) selon la revendication 4, **caractérisé en ce que** ledit aimant (21) est un aimant permanent et/ou un électroaimant.

6. Système de traction (1) selon la revendication 5, **caractérisé en ce que** chacun desdits éléments de rail (3) comprend au moins un tube amagnétique (13) comprenant une face plate supérieure (14), ledit tube amagnétique (13) étant installé avec ladite face supérieure (14) sensiblement alignée avec le pavage de sol autour du périmètre de ladite piscine (4).

7. Système de traction (1) selon la revendication 6, **caractérisé en ce que** ledit élément de transmission (8) comprend également au moins un cadre de support (17) pour ledit aimant (21) et au moins deux roues (23) pour permettre l'action de coulissement dudit élément de transmission (8) à l'intérieur dudit tube amagnétique (13).

8. Système de traction (1) selon la revendication 3, **caractérisé en ce que** ledit élément tiré (9) comprend également au moins un cadre de support pour ledit aimant (21) et au moins deux roues (22) afin de coulisser le long du pavage externe (33) de ladite piscine (4) en tandem avec ledit élément de transmission (8).

9. Système de traction (1) selon la revendication 2, **caractérisé en ce que** ledit élément tiré (9) est installé à l'intérieur de la structure de ladite paroi mobile (2) afin d'être fixé à ladite paroi (2).

10. Système de traction (1) selon la revendication 6, **caractérisé en ce que** lesdits moyens d'entraînement (10) comprennent un système de courroie et de poulie, ou système de câble et de treuil positionné à l'intérieur dudit tube (13) et/ou dans au moins un compartiment situé sous le pavage de sol dudit périmètre de la piscine (4).

11. Système de traction (1) selon la revendication 6, **caractérisé en ce que** lesdits moyens d'entraînement comprennent une crémaillère positionnée à l'intérieur dudit tube et/ou dans au moins un compartiment situé sous le pavage de sol dudit périmètre de la piscine. 5

12. Système de traction (1) selon la revendication 6, **caractérisé en ce que** lesdits moyens d'entraînement (10) comprennent un vérin oléo-dynamique positionné à l'intérieur dudit tube (13) et/ou dans au moins un compartiment situé sous le pavage de sol dudit périmètre de la piscine (4). 10

15

20

25

30

35

40

45

50

55

Fig. 1

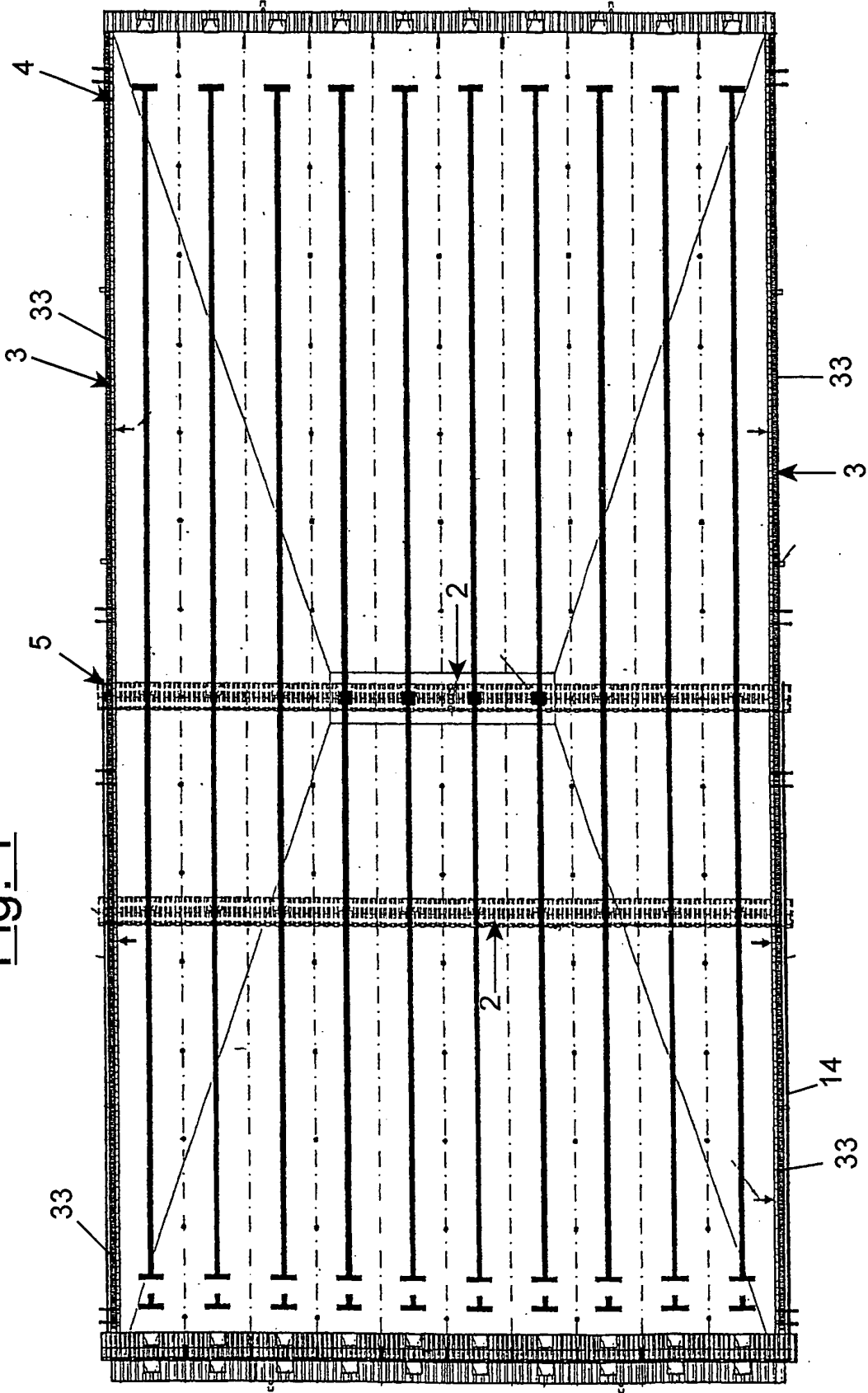

Fig. 2

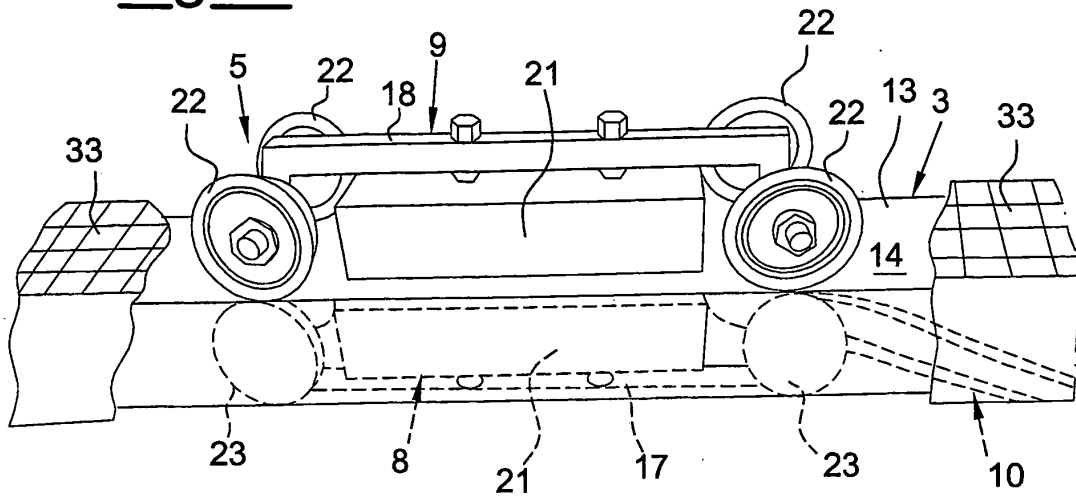
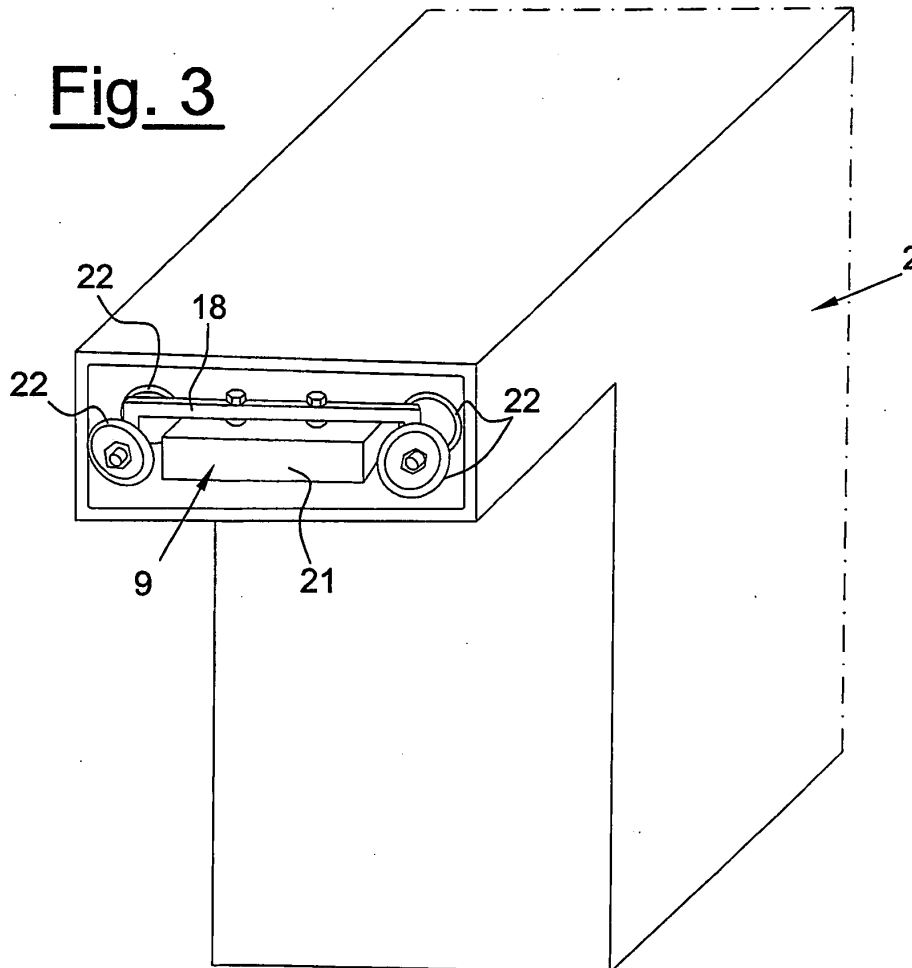

Fig. 3





**REFERENCES CITED IN THE DESCRIPTION**

*This list of references cited by the applicant is for the reader's convenience only. It does not form part of the European patent document. Even though great care has been taken in compiling the references, errors or omissions cannot be excluded and the EPO disclaims all liability in this regard.*

**Patent documents cited in the description**

- EP 1288326 A [0009]