



(11) **EP 1 806 712 A1**

(12) **EUROPEAN PATENT APPLICATION**
published in accordance with Art. 158(3) EPC

(43) Date of publication:
11.07.2007 Bulletin 2007/28

(51) Int Cl.:
G09F 3/03 (2006.01)

(21) Application number: **04742044.3**

(86) International application number:
PCT/ES2004/000315

(22) Date of filing: **05.07.2004**

(87) International publication number:
WO 2006/013216 (09.02.2006 Gazette 2006/06)

(84) Designated Contracting States:
AT BE BG CH CY CZ DE DK EE ES FI FR GB GR HU IE IT LI LU MC NL PL PT RO SE SI SK TR
Designated Extension States:
AL HR MK

(72) Inventor: **BAUCELLS GRANELL, Jaime**
E-08120 Barcelona (ES)

(71) Applicant: **Brooks/Todo Seguridad en Espana, S.A.**
08120 La Llagosta (Barcelona) (ES)

(74) Representative: **Gallego Jiménez, José Fernando**
BGA - Barroso, Garo & Asociados,
Avda. Diagonal 421, 2o
08008 Barcelona (ES)

(54) **HIGH SECURITY SEAL**

(57) The invention concerns a flexible plastic band (2), terminated by a widened portion (3) provided with an extension (4) traversed by a channel (5), through which the band may be inserted, providing the channel (5) with retaining means enabling the band to be passed through in the introduction direction thereof, but which prevents its movement in the opposite direction, provided with a container (7), such that the channel (5) passes through

said container with an inlet and an outlet through its opposite walls; a box (8) adapted to be anchored in said container, said box being provided with a channel (9) having a retaining framework (10) which coincides with the channel (5) of the extension when the box remain anchored in the container, and a retaining framework (10) rigidly fixed in the box and slightly projecting transversely from the channel (5) of the extension.

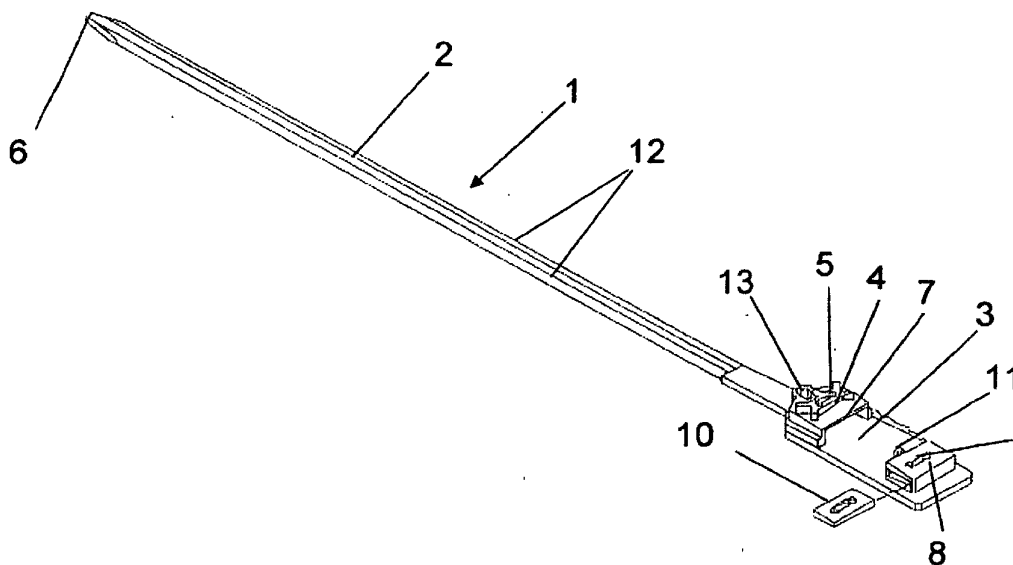

Fig. 1a

EP 1 806 712 A1

DescriptionTechnical field of the invention

[0001] The present invention relates to the technical field of seals intended for maintaining inviolability of transported and handled articles and for storing and providing information about the article itself and about history thereof. More specifically, the present invention relates to a high security seal, comprising a flexible plastic band or the like, which is terminated by a widened portion provided with an extension traversed by a channel, through which the band can be inserted by its free end, the channel having retaining means enabling the band to be passed through in the introduction direction thereof, but preventing it from moving in the opposite direction.

Background of the invention

[0002] In the technical field of security seals, locking devices of collar-type including an elongated and flexible band which is closed by twisting itself into a loop and is retained in said locking position by means of engaging teeth formed on the band with retaining means arranged in the slot in which the band is inserted when the seal is locked, are known. This kind of locking devices allows partially guaranteeing inviolability of the sealed article content or container. When the sealed article or container are received with the locking device intact, the recipient of the article or container is sure that no modifications in the sealed articles have been made since the device was locked, since, as it is known, it is not reusable. In the present document, said security devices are referred to as seals.

[0003] From Spanish utility models ES-U-1027598 and ES-U-1030846, whose owner is the present applicant, respective security seals are known, constituted by a flexible plastic collar or the like, which is terminated by a widened portion having a passage through which the collar can be inserted by its free end, the passage including retaining means of the collar arranged inside a housing for this purpose. Specifically, document ES-U-1027598 is characterized in that the passage has mounted on it a transversal metal plate having an opening, from which contour approximately radial indentations or cuts extend, thereby bounding flexible intermediate flanges or tabs, which are slightly inclined in the same direction from its starting point; the inner edge of these tabs bounding a passage with a minimum contour which is approximately the same than that of the section of the portions of the flexible band not having clamping members or teeth, but smaller than that bounded by said clamping members or teeth; the said tabs or flanges bending towards its inclination direction in order to enable the clamping members or teeth of the flexible band to be passed through, while acting as retaining elements in the opposite direction, the clamping members or teeth resting against them, preventing them from moving backwards'.

[0004] One of the drawbacks of this known kind of seals is that when applying heat to the locking area of the seal, for example with a simple hairdryer, it is possible that the insertion slot for the band is expanded to such an extent that the band can be removed without damaging the material. Then, and with the band introduced again in the seal, the slot may be caused to substantially recover its original shape, so that the addressee of the article is not aware that its content has been violated.

[0005] The present invention proposes an improvement with respect to the above-mentioned seals, since the retaining means which hold the band in its locking position is made of metal, so that application of heat may not deform it as much as to remove the band. The necessary heat to expand said means of metal would totally destroy the remainder portion of the seal which is typically made of plastic, so that the attempt to access the content of the sealed article would become apparent.

Description of the invention

[0006] With such purpose, the object of the present invention is to provide a high security seal wherein the retaining means consists of:

- a receptacle made up on the extension of the widened portion of the flexible band, such that a channel passes through said receptacle with an inlet and an outlet through its opposite walls,
- a box adapted to be inserted and anchored in said receptacle, with such a structure that its outer periphery substantially matches in shape and size the inner walls of the receptacle, said box being provided with a channel of a retaining framework which coincides with the channel of the extension when said box is anchored inside the receptacle, and
- a retaining framework rigidly fixed inside the box and slightly protruding transversally from at least one of the sides of the retaining framework channel, and thus from the channel of the extension, contained inside the box, such that it enables the band to be passed through in the introduction direction thereof, but prevents it from moving in the opposite direction.

[0007] According to another feature of the present invention, the material of the retaining framework has an expansion coefficient which is substantially lower than the expansion coefficient of the box and the receptacle.

[0008] Another feature of the invention consists in that the material of the retaining framework is a metal and the material of the box and the receptacle is a plastic.

[0009] According to another feature of the present invention, the retaining framework is provided with metal teeth which are inclined towards the advancing direction of the flexible band, and which slightly protrude transversally through the retaining framework channel and the channel of the extension, such that they enable said band to be passed through in the introduction direction thereof,

but prevent it from moving in the opposite direction.

[0010] According to another feature of the present invention, the box and the receptacle are adapted so that the first of them is anchored inside the latter by means of a harpoon anchoring system, the extension having a housing for the box harpoon.

[0011] According to a still further feature of the present invention, the flexible band is flat with both of its longitudinal edges provided with circular extensions which gradually reach their final dimension starting from the free end of said band, and the retaining framework is adapted to apply its retaining effect substantially in said extensions.

[0012] A further feature of the present invention is that the flexible band is provided with protrusions substantially distributed all over its length, at the area in which the retaining framework is applied.

[0013] According to a further feature of the present invention, the material of the seal, and thus of the receptacle, and the material of the box have different expansion coefficients, the material of the box being more resistant than that of the seal.

[0014] A still further feature of the present invention consists in that the material of the seal is polyamide and the material of the box is polycarbonate.

[0015] Finally, another feature of the present invention is that the seal comprises a housing adapted to contain a chip in which information can be written repeatedly and from which said information can be read.

Brief description of the drawings

[0016] In the attached drawings a non-limiting exemplary form of embodiment of the high security seal object of the invention is illustrated. In said drawings:

Figs. 1 a and 1 b are perspective views of the seal of the present invention in an open and locked position, respectively;

Figs. 2a and 2b are two top and bottom plan views of the seal of the present invention, respectively;

Fig. 3 is a detail A of the seal, indicated in Fig. 2a;

Fig. 4 is a view of part of the widened portion and the extension of the seal of the present invention from an end thereof;

Fig. 5 is a section B-B' of the seal, indicated in Fig. 4;

Fig. 6 is a plan view of the box of the seal of the present invention;

Fig. 7 is a section view of Fig. 6 according to section A-A';

Fig. 8 is a lateral view of the box shown in Fig. 6; and

Fig. 9 is a top view of the box shown in Figs. 6 and 8.

Detailed description of the drawings

[0017] A form of embodiment of the present invention is shown in said drawings.

[0018] An exemplary embodiment of the high security

seal 1 of the present invention is described below.

[0019] Figs. 1a and 1b show perspective views of the seal 1 in an open and locked position, respectively. The outer structure of said seal 1 is similar to that corresponding to known seals of this kind.

[0020] The seal 1 essentially comprises a flexible band 2, a widened portion 3, an extension 4 and a channel 5 in the extension 4 for passing the band 2 through it. These are the basic components which are common to the entire prior art seals of this kind. As it is known, these seals are operated so that the flexible band 2 is inserted through the channel 5 of the extension 4, and said channel or slot 5 has retaining means enabling the band 2 to be advanced through it, but preventing it from being removed therefrom.

[0021] This retaining means is the novel element with respect to the known devices. In the case of the present invention, a receptacle 5 is formed on the extension 4, adapted to contain a block or box 8. In turn, this box 8 has installed inside of it, rigidly, that is, without any possible movement, a retaining framework 10, preferably made of metal. The retaining framework 10 has been represented in Fig. 6, it having been omitted in Figs. 7 to 9 for clarity purposes.

[0022] Similarly, the receptacle 5, as well as the box 8, are adapted so that the latter is housed inside the first of them, also without any possible mutual movement.

[0023] In the preferred form of embodiment of the present invention, this locking of the box 8 inside the receptacle 5 is achieved by means of a harpoon anchoring system 11. The harpoon 11 is part of the box 8, as clearly shown in Figs. 6 to 9, and said harpoon 11 is anchored in a housing 13 made up on the extension 4 following the receptacle 7. At the same time, the channel 9 of the box 8 must coincide with the channel 5 of the extension 4; thus, a duct is created through which the band 2 can be passed.

[0024] The retaining framework 10 is arranged inside the box 8, forming part of it, or several tooth-like elements in the retaining framework slightly protrude from the contour of the channel 9, and thus, from the channel 5. The protruding part of the metal retaining framework 10 is suitable to enable the band 2 to be passed in the locking direction of the seal 1, but to prevent said band 2 from being removed in the opposite direction. This can be achieved by means of said part or teeth being inclined in the advancing direction of the band 2, so that when an attempt to extract the band 2 is carried out, these teeth are 'stuck' into the plastic material of the band, and prevent it from moving backwards.

[0025] In most of the prior art seals, this retention of the band 2 is achieved by means of mutual engagement of plastic protrusions made up on the band 2 from the same material than the whole seal 1. It has been found that through application of heat, it is possible to expand the slot 5 (which is also made of plastic material) and the band 2 can be slid in order to open the seal 1. Then, by applying heat again, the original shape of the seal 1

can be recovered, so that it is very difficult, and sometimes impossible, detecting a possible violation of the content to be protected.

[0026] The seal 1 of the present invention avoids this kind of intrusion by introducing a metal retaining framework 10 which can be considered insensible to heat application with regard to variation of its dimensions. Thus, even at quite high temperatures, which usually are able to expand plastic materials, the retaining framework 10 remains always anchored to the band 2, and extraction of the latter is prevented. This allows to overcome the drawbacks of the prior art.

[0027] The shape and materials of the components of this retaining system are not essential to accomplish the purpose of the present invention, as long as the material of the retaining framework 10 has an expansion coefficient much higher than that of the receptacle 7 and the extension 4, and, generally, than that of the whole seal 1. Thus, it is prevented that said seal 1 may be opened by simply applying heat.

[0028] In the preferred form of embodiment of the invention, the flexible band 2 is flat with longitudinal edges 12 provided with circular extensions and, obviously, channels 5 and 9 have a corresponding shape to enable said band 2 to be passed through. The retaining framework 10 rigidly inserted in the box 8 is also adapted to apply its teeth and, therefore, its retaining action, on said extensions of the longitudinal edges 12 of the flexible band 2.

[0029] The nature, as well as the way of implementing the present invention having been sufficiently described, it is stated that all that does not alter, change or modifies its essential principle, may be subject to detail variations.

Claims

1. High security seal (1), comprising a flexible plastic band (2) or the like, which is terminated by a widened portion (3) provided with an extension (4) traversed by a channel (5), through which the band can be inserted by its free end (6), the channel (5) having retaining means enabling the band to be passed through in the introduction direction thereof, but preventing it from moving in the opposite direction, **characterized in that** the retaining means comprises:

- a receptacle (7) made up on the extension, such that the channel (5) passes through said receptacle with an inlet and an outlet through its opposite walls,

- a box (8) adapted to be inserted and anchored in said receptacle, with such a structure that its outer periphery substantially matches in shape and size the inner walls of the receptacle, said box being provided with a retaining framework (10) channel (9) which coincides with the channel (5) of the extension when said box is an-

chored inside the receptacle, and

- a retaining framework (10) rigidly fixed inside the box and slightly protruding transversally from at least one of the sides of the retaining framework channel, and thus from the channel (5) of the extension, contained inside the box, such that it enables the band to be passed through in the introduction direction thereof, but prevents it from moving in the opposite direction.

2. High security seal (1) according to claim 1, **characterized in that** the material of the retaining framework (10) has an expansion coefficient which is substantially lower than the expansion coefficient of the box (8) and the receptacle (7).

3. High security seal (1) according to claim 2, **characterized in that** the material of the retaining framework (10) is a metal and the material of the box (8) and the receptacle (7) is a plastic.

4. High security seal (1) according to any one of the preceding claims, **characterized in that** the retaining framework (10) is provided with metal teeth which are inclined towards the advancing direction of the flexible band (2), and which slightly protrude transversally through the retaining framework channel (9) and the channel (5) of the extension, such that they enable said band to be passed through in the introduction direction thereof, but prevent it from moving in the opposite direction.

5. High security seal (1) according to any one of the preceding claims, **characterized in that** the box (8) and the receptacle (7) are adapted so that the first of them is anchored inside the latter by means of a harpoon anchoring system (11), the extension (4) having a housing (13) for the box harpoon.

6. High security seal (1) according to any one of the preceding claims, **characterized in that** the flexible band (2) is flat with both of its longitudinal edges (12) provided with extensions which gradually reach their final dimension starting from the free end of said band, and the retaining framework (10) is adapted to apply its retaining effect substantially in said extensions.

7. High security seal (1) according to any one of the preceding claims, **characterized in that** the flexible band (2) is provided with protrusions substantially distributed all over its length, at the area in which the retaining framework (10) is applied.

8. High security seal (1) according to any one of the preceding claims, **characterized in that** the material of the seal, and thus of the receptacle (7), and the material of the box (8) have different expansion co-

efficients, the material of the box being more resistant than that of the seal.

9. High security seal (1) according to any one of the preceding claims, **characterized in that** the material of the seal is polyamide and the material of the box (8) is polycarbonate. 5
10. High security seal (1) according to any one of the preceding claims, **characterized in that** it comprises a housing adapted to contain a chip in which information can be written repeatedly and from which said information can be read. 10

15

20

25

30

35

40

45

50

55

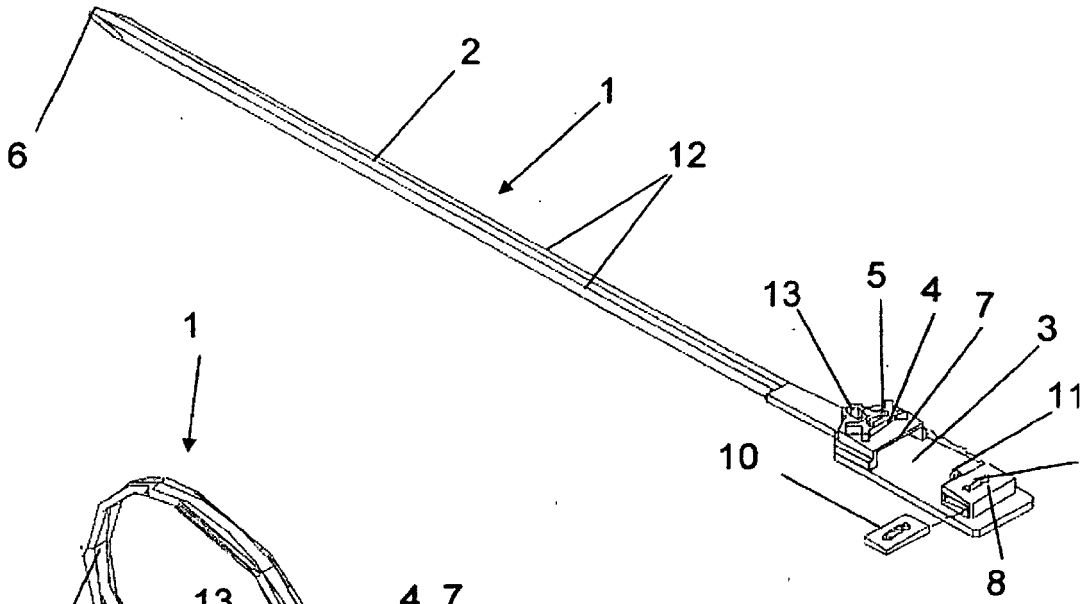

Fig. 1a

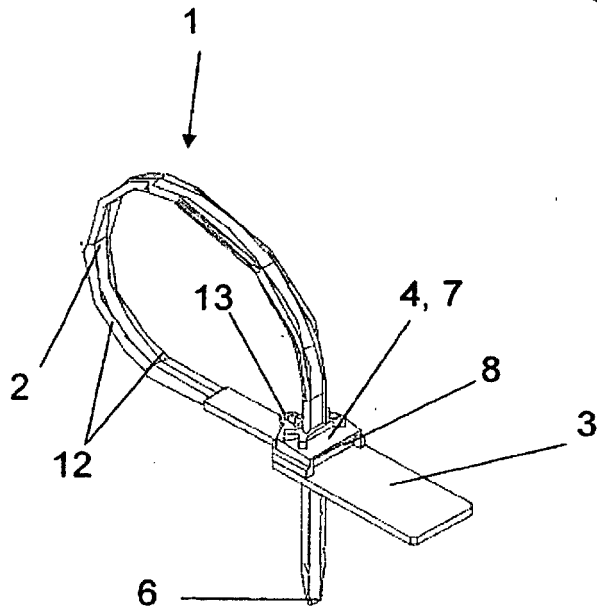

Fig. 1b

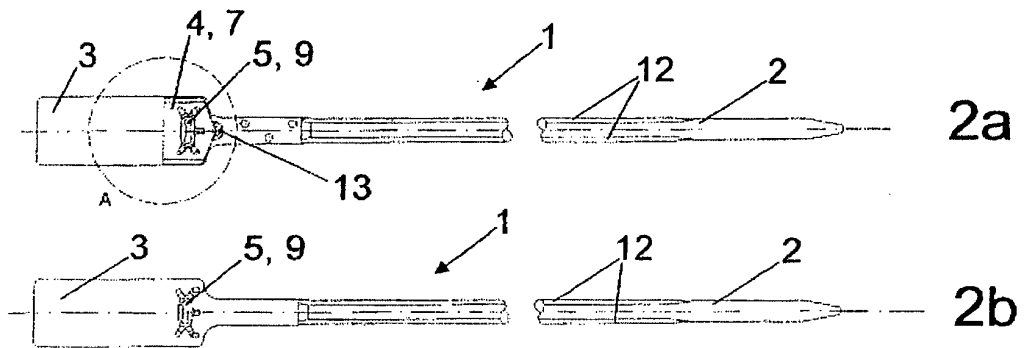
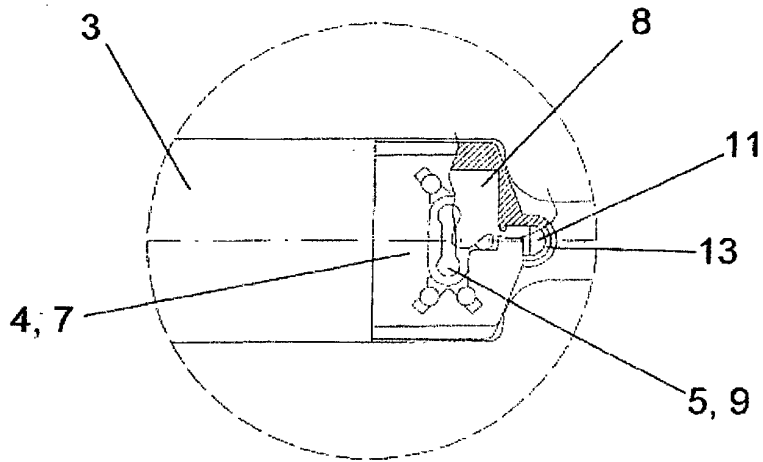

Fig. 2



Detail A

Fig. 3

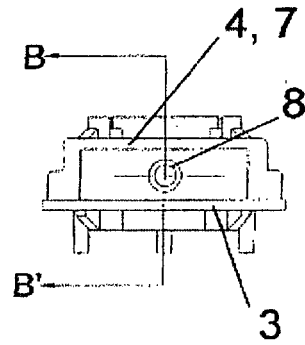
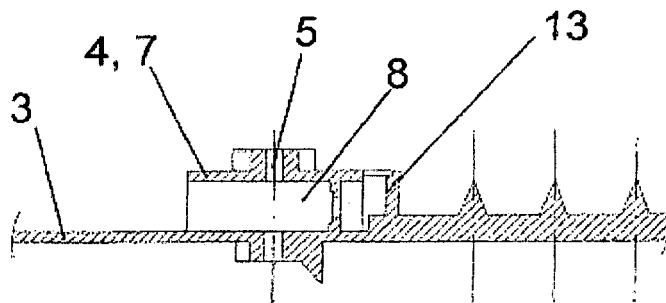

Fig. 4



Section B-B'

Fig. 5

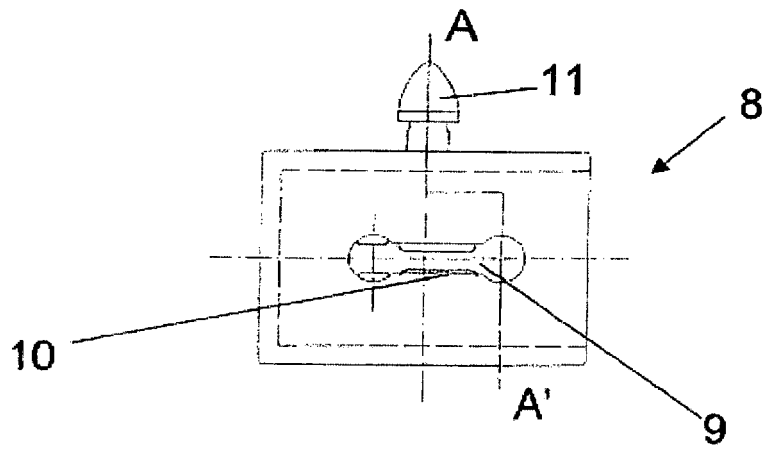

Fig. 6

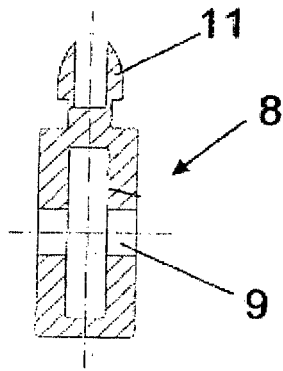

Fig. 7

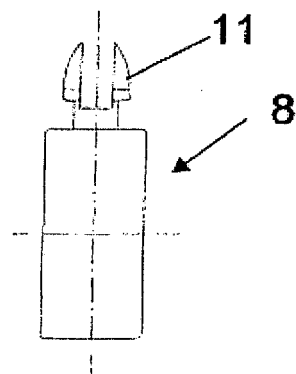

Fig. 8

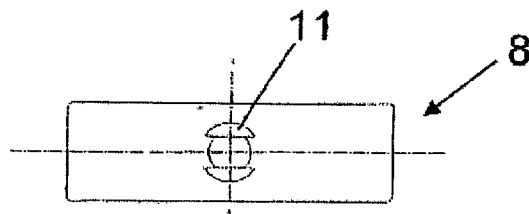

Fig. 9

INTERNATIONAL SEARCH REPORT

International application No. PCT/ ES 2004/000315
--

A. CLASSIFICATION OF SUBJECT MATTER IPC 7: G09F3/03 According to International Patent Classification (IPC) or to both national classification and IPC		
B. FIELDS SEARCHED Minimum documentation searched (classification system followed by classification symbols) IPC 7: G09F Documentation searched other than minimum documentation to the extent that such documents are included in the fields searched Electronic data base consulted during the international search (name of data base and, where practicable, search terms used) CIBEPAT,EPODOC, WPI, PAJ		
C. DOCUMENTS CONSIDERED TO BE RELEVANT		
Category*	Citation of document, with indication, where appropriate, of the relevant passages	Relevant to claim No.
X	FR 2 632 431 A (MALACHOWSKY) 08.12.1989 abstract ; figure 3	1 - 4
Y		8
Y	GB 2 265 114 A (W A Deutscher) 22.09.1993 abstract	8
A	US 6 109 673 A (Olshausen) 29.08.2000 Column 5, line s 24- 27.	9
A	US 5 337 503 A (Goby) 16.08.1994 abstract, figures.	10
<input type="checkbox"/> Further documents are listed in the continuation of Box C. <input checked="" type="checkbox"/> See patent family annex.		
* Special categories of cited documents: "A" document defining the general state of the art which is not considered to be of particular relevance "E" earlier document but published on or after the international filing date "L" document which may throw doubts on priority claim(s) or which is cited to establish the publication date of another citation or other special reason (as specified) "O" document referring to an oral disclosure, use, exhibition or other means "P" document published prior to the international filing date but later than the priority date claimed		"T" later document published after the international filing date or priority date and not in conflict with the application but cited to understand the principle or theory underlying the invention "X" document of particular relevance; the claimed invention cannot be considered novel or cannot be considered to involve an inventive step when the document is taken alone "Y" document of particular relevance; the claimed invention cannot be considered to involve an inventive step when the document is combined with one or more other such documents, such combination being obvious to a person skilled in the art "&" document member of the same patent family
Date of the actual completion of the international search 20 September 2004 (20.09.04)		Date of mailing of the international search report 29 September 2004 (29.09.04)
Name and mailing address of the ISA/ S.P.T.O.		Authorized officer
Facsimile No.		Telephone No.

Form PCT/ISA/210 (second sheet) (July 1992)

INTERNATIONAL SEARCH REPORT
 Information on patent family members

 International Application No
 PCT/ ES 2004/000315

Patent document cited in search report	Publication date	Patent family member(s)	Publication date
FR2632431 A B	08.12.1989	NONE	-----
GB 2265114 A	22.09.1993	AU 3288593 A FR 2690194 AB JP 6026267 A AU 664727 B	23.09.1993 22.10.1993 01.02.1994 30.11.1995
US 6109673 A	29.08.2000	WO 0111594 A AU 6201300 A US 6371539 B	15.02.2001 05.03.2001 16.04.2002
US 5337503 A	16.08.1994	DE 9216418 U EP 0550815 AB EP 19920119439 DE 59204930 D ES 2081546 T CH 686593 A	11.03.1993 14.07.1993 13.11.1992 15.02.1996 01.03.1996 30.04.1996

REFERENCES CITED IN THE DESCRIPTION

This list of references cited by the applicant is for the reader's convenience only. It does not form part of the European patent document. Even though great care has been taken in compiling the references, errors or omissions cannot be excluded and the EPO disclaims all liability in this regard.

Patent documents cited in the description

- ES 1027598 U [0003] [0003]
- ES 1030846 U [0003]