

(19)



(11)

**EP 1 813 178 A2**

(12)

**EUROPEAN PATENT APPLICATION**

(43) Date of publication:

**01.08.2007 Bulletin 2007/31**

(51) Int Cl.:

**A47K 10/16<sup>(2006.01)</sup>**

(21) Application number: **06026405.8**

(22) Date of filing: **20.12.2006**

(84) Designated Contracting States:

**AT BE BG CH CY CZ DE DK EE ES FI FR GB GR  
HU IE IS IT LI LT LU LV MC NL PL PT RO SE SI  
SK TR**

Designated Extension States:

**AL BA HR MK YU**

(72) Inventor: **Tronchetti, Sauro**  
**55100 Lucca (Lucca) (IT)**

(74) Representative: **Forattini, Amelia**  
**Internazionale Brevetti**  
**Ingg. ZINI, MARANESI & C. S.r.l.**  
**Piazza Castello 1**  
**20121 Milano (IT)**

(30) Priority: **26.01.2006 IT MI20060130**

(71) Applicant: **Industrie Cartarie Tronchetti S.p.A.**  
**55023 Borgo a Mozzano (Lucca) (IT)**

(54) **Paper roll, particularly of the toilet paper or kitchen paper type**

(57) A toilet/kitchen paper roll (1), having a first flap (3) pasted by means of a line of paste (5) which is colored

and does not extend along the entire width of the roll (1) so as to facilitate identification of the flap (3) to be torn and facilitate opening.

*Fig. 2*

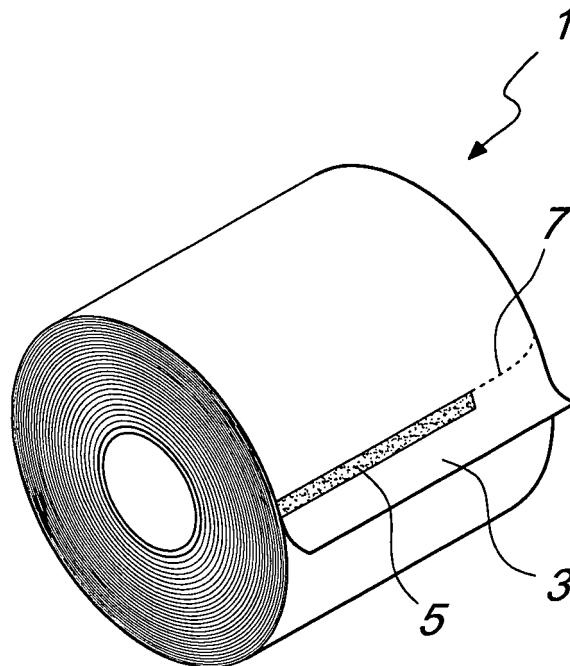

**EP 1 813 178 A2**

## Description

[0001] The present invention relates to a paper roll, particularly of the toilet/kitchen type.

[0002] As is known, the end flap of a roll of toilet/kitchen paper is pasted in order to prevent the roll from unwinding during packaging and transport.

[0003] When the user removes the new roll from the package, he or she has to locate the pasted end flap and tear it in order to open the roll and start using it.

[0004] Figure 1 illustrates a roll of toilet/kitchen paper A in which a continuous line of paste B fixes the end flap C to the roll.

[0005] The operation for opening the roll is never easy and in some cases is definitely laborious, due to the fact that the flap to be torn is not easily identifiable and the pasting region is so large as to force the user to tear a considerable amount of paper before being able to unroll the roll correctly.

[0006] The aim of the present invention is to provide a paper roll with easier opening which overcomes the drawbacks of the cited prior art.

[0007] An object of the invention is to provide a toilet/kitchen paper roll in which the first flap to be torn can be immediately identified.

[0008] A further object of the invention is to provide a toilet/kitchen paper roll which can be produced with machinery and materials that are already commercially available and are normally used in this field.

[0009] A further object of the invention is to provide a paper roll which can be manufactured at competitive costs.

[0010] This aim and other objects, which will become better apparent hereinafter, are achieved by a paper roll, particularly of the toilet/kitchen type, characterized in that it comprises a flap which is pasted by means of a line of paste which does not extend along the entire width of the roll.

[0011] Further characteristics and advantages will become better apparent from the description of preferred but non-exclusive embodiments of the invention, illustrated by way of non-limiting example in the accompanying drawings, wherein:

Figure 1 is a perspective view of a toilet/kitchen paper roll provided with an end flap which is pasted according to the prior art;

Figure 2 is a view, similar to Figure 1, of a roll of toilet/kitchen paper provided with a flap with easier opening according to one aspect of the invention;

Figure 3 is a view, similar to the preceding figures, of a roll of toilet/kitchen paper provided with a flap with easier opening according to a further aspect of the invention.

[0012] With reference to the cited figures, a roll of toilet/kitchen paper according to the invention, generally designated by the reference numeral 1, includes an end flap

3 which is pasted to the roll by means of a line of paste 5 which does not extend along the entire width of the roll but leaves an unpasted region 7 of approximately 10-20 mm.

5 [0013] The line of paste 5 may be colored so as to facilitate the identification of the flap 3 on the roll.

[0014] Figure 3 illustrates a roll of toilet/kitchen paper according to another aspect of the invention, generally designated by the reference numeral 101, which includes an end flap 103 which is pasted to the roll by virtue of a discontinuous line of paste 105.

10 [0015] As in the preceding embodiment, the discontinuous line of paste 105 does not extend along the entire width of the roll but leaves an unpasted region 107 of approximately 10-20 mm.

15 [0016] In this case also, the line of discontinuous paste 105 may be colored so as to facilitate the identification of the flap 103 on the roll.

[0017] The method for producing the roll of paper according to the present invention is performed by installing a discontinuous flap pasting blade instead of the ordinary continuous pasting blade.

[0018] The coloring of the pasting region may be obtained by diluting food-grade ink in the paste.

20 [0019] The color of the paste is chosen so as to produce an adequate contrast between the color of the paper and the color of the pasting region.

[0020] In practice it has been found that the invention achieves the intended aim and objects, providing a roll of toilet/kitchen paper which has the final flap pasted so as to facilitate opening by virtue of the presence of an unpasted region.

25 [0021] Coloring of the pasting region facilitates the identification of the flap to be opened.

30 [0022] The invention may of course be applied also to other types of paper roll other than the toilet paper shown here.

35 [0023] This application claims the priority of Italian Patent Application No. M12006A000130, filed on 26 January 2006, the subject matter of which is incorporated herein by reference.

40 [0024] The paper roll, particularly of the toilet paper or kitchen paper type according to the invention is susceptible of numerous modifications and variations, within the scope of the appended claims. All the details may be replaced with technically equivalent elements.

45 [0025] The materials used, as well as the dimensions, may of course be any according to the requirements and the state of the art.

## Claims

- 50 1. A paper roll, particularly of the toilet/kitchen type, characterized in that it comprises a flap which is pasted by means of a line of paste which does not extend along the entire width of the roll.

2. The paper roll according to claim 1, **characterized in that** said line of paste is colored so as to facilitate the identification of the pasted flap.
3. The paper roll according to claim 1 or 2, **characterized in that** said unpasted region has an extension of approximately 10-20 mm. 5
4. The paper roll according to one or more of the preceding claims, **characterized in that** said line of paste is discontinuous or segmented. 10
5. A method for manufacturing a roll of paper of the toilet/kitchen type, **characterized in that** it comprises partial pasting of the end flap. 15
6. A method for manufacturing a roll of paper of the toilet/kitchen type, **characterized in that** it comprises diluting a color or dye into a paste for pasting the first flap of the roll. 20
7. An apparatus for manufacturing a roll of paper of the toilet/kitchen type, **characterized in that** it comprises a flap pasting blade which is interrupted, i.e., does not cover the entire width of the roll. 25
8. An apparatus for manufacturing a roll of paper of the toilet/kitchen type, **characterized in that** it comprises a flap pasting blade with spaced interruptions adapted to produce a segmented pasting line. 30

35

40

45

50

55

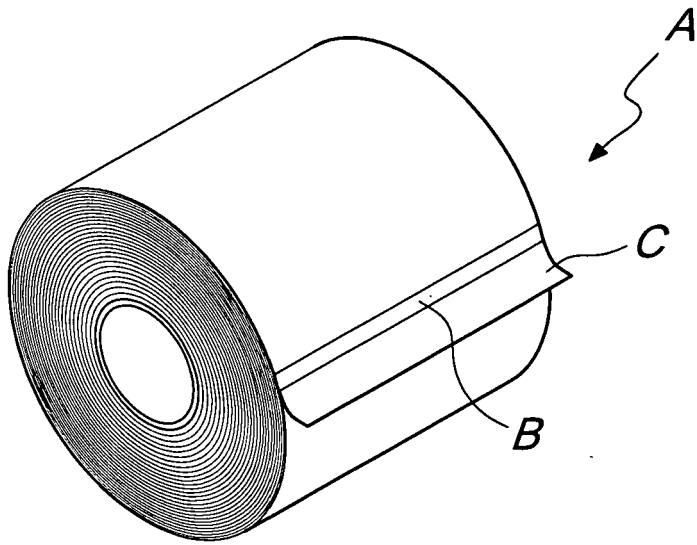

*Fig. 1*  
PRIOR ART

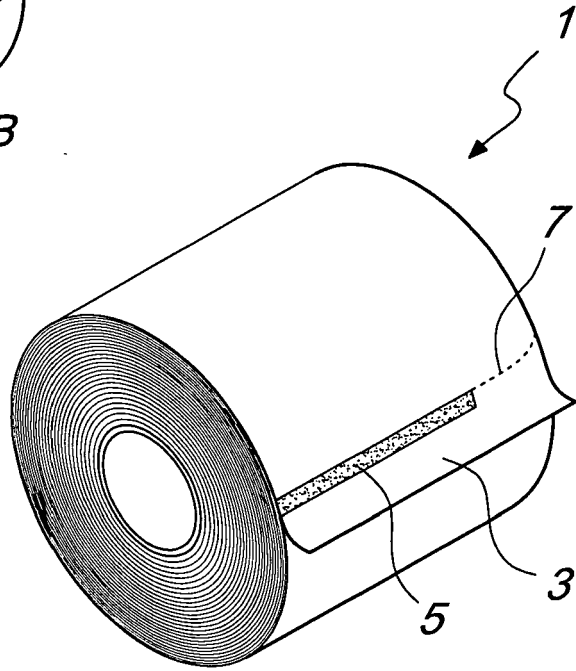

*Fig. 2*

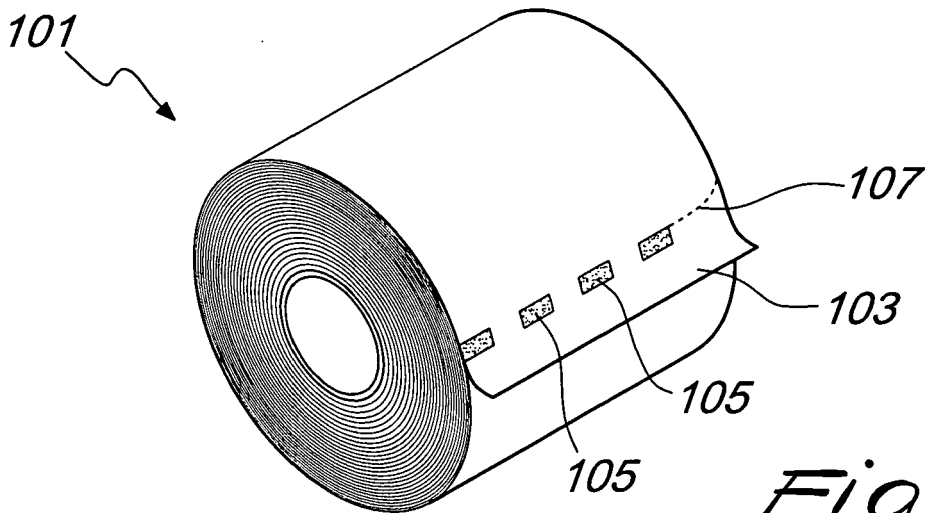

*Fig. 3*

**REFERENCES CITED IN THE DESCRIPTION**

*This list of references cited by the applicant is for the reader's convenience only. It does not form part of the European patent document. Even though great care has been taken in compiling the references, errors or omissions cannot be excluded and the EPO disclaims all liability in this regard.*

**Patent documents cited in the description**

- IT M12006000130 A [0023]