



(11) **EP 1 815 085 B1**

(12) **EUROPEAN PATENT SPECIFICATION**

(45) Date of publication and mention of the grant of the patent:
25.03.2009 Bulletin 2009/13

(21) Application number: **05801763.3**

(22) Date of filing: **21.10.2005**

(51) Int Cl.:
E04F 15/024^(2006.01)

(86) International application number:
PCT/EP2005/055467

(87) International publication number:
WO 2006/053813 (26.05.2006 Gazette 2006/21)

(54) **SUPPORT STRUCTURE FOR ELEVATED FLOOR ASSEMBLY**

STÜTZSTRUKTUR FÜR EINE AUFGESTÄNDERTE FUSSBODENANORDNUNG

STRUCTURE DE SUPPORT POUR ENSEMBLE PLANCHER SURELEVE

(84) Designated Contracting States:
AT BE BG CH CY CZ DE DK EE ES FI FR GB GR HU IE IS IT LI LT LU LV MC NL PL PT RO SE SI SK TR
Designated Extension States:
HR YU

(30) Priority: **16.11.2004 LU 91123**

(43) Date of publication of application:
08.08.2007 Bulletin 2007/32

(73) Proprietor: **Uniflair Industries S.P.A.**
35026 Conselve (IT)

(72) Inventor: **ISAAC, Eric, Peter**
L-5335 Moutfort (LU)

(74) Representative: **Lambert, Romain Ramon et al**
Office Ernest T. Freylinger S.A.,
234, route d'Arlon,
B.P. 48
8001 Strassen (LU)

(56) References cited:
EP-A- 1 247 922 **DE-A1- 3 935 919**
DE-A1- 4 132 989 **DE-U1- 8 911 464**

EP 1 815 085 B1

Note: Within nine months of the publication of the mention of the grant of the European patent in the European Patent Bulletin, any person may give notice to the European Patent Office of opposition to that patent, in accordance with the Implementing Regulations. Notice of opposition shall not be deemed to have been filed until the opposition fee has been paid. (Art. 99(1) European Patent Convention).

Description

Introduction

[0001] The present invention relates to a support structure for an elevated floor assembly.

[0002] Such support structures generally comprise a number of pedestals, each including a column, a supporting head fixed to the upper end of the column, so as to be capable of supporting the floor panels of the elevated floor assembly, and a base plate fixed to the lower end of the column for providing a support platform for the pedestal resting on the base floor. The length of the column is generally adjustable, so that the height of the pedestal can be adjusted. In order to be capable of supporting heavy floor loads, all the supporting parts of the pedestal are generally made of metal, most often steel. For increased rigidity and strength, such support structures generally further comprise panel stringers coupled between adjacent pedestals to form a generally square grid when viewed from above. Floor panels normally rest on the panel stringers and form the elevated floor.

[0003] Such a support structure for an elevated floor assembly is e.g. disclosed in US 4,277,923, wherein the structure comprises a plurality of pedestals and panel stringers coupled between adjacent pedestals. Each pedestal has a column with a supporting head on an upper end of the column and a base plate on the lower end of the column. The supporting head comprises radially protruding supporting arms for connecting panel stringers thereto. Each panel stringer has a generally inverted U-shaped cross-section with two generally parallel side portions and an interconnecting portion, wherein the interconnecting portion rests on the radially protruding supporting arm. In order to prevent the panel stringers from moving with respect to the supporting head, self-tapping screws are driven through the panel stringers and the supporting head. This constitutes a rather cumbersome and time-consuming task. Furthermore, the rigidity of the support structure is not adequate.

[0004] EP-A-1 247 922 discloses a support structure according to the preamble of claim 1.

Object of the invention

[0005] It is an object of the present invention is to provide an improved support structure for an elevated floor assembly, wherein a rigid support structure can be quickly erected.

General description of the invention

[0006] In order to overcome the abovementioned problems, the present invention proposes a support structure for an elevated floor assembly comprising a plurality of pedestals and panel stringers coupled between adjacent pedestals, each pedestal having a column with a supporting head on an upper end of the column and a base

plate on the lower end of the column, the supporting head having radially protruding supporting arms for connecting the panel stringers thereto, and each panel stringer having a generally inverted U-shaped cross-section with two generally parallel side portions and an interconnecting portion, wherein the interconnecting portion rests on the radially protruding supporting arm of the supporting head of the pedestal. At an end portion of the panel stringer, at least one of the side portions comprises a cavity proximate the interconnecting portion and a guide leading from an edge of the side portion remote from the interconnecting portion to the cavity. The supporting arm comprises at least one lateral protrusion configured to be received in the cavities when the panel stringer is connected to the supporting arm of the pedestal. According to an important aspect of the invention, the cavity and the guide are formed by an indentation on the inner surface, the guide extending from an edge of the side portion into the cavity. In order to couple a panel stringer to a pedestal, the guide of the side portion of the panel stringer is aligned with the protrusion of the supporting arm of the pedestal. The panel stringer is then pushed downwards onto the supporting arm of the pedestal. Due to the guide, the protrusion is thereby led through the guide into the cavity. The protrusion and cavity guarantees a precise and correct position of the panel stringer with respect to the pedestal, thereby obtaining an improved support structure for an elevated floor assembly. Once the protrusion is arranged in the cavity, the panel stringer is prevented from sliding on the supporting arm, thereby eliminating the necessity of driving a screw through panel stringer and supporting arm. The support structure can hence be more easily and more quickly erected, which has a positive effect on labour costs. Preferably, both side portions comprise a cavity and a guide and the supporting arm comprises two protrusions cooperating with the two cavities.

[0007] The cavities are preferably dimensioned so as to securely receive the protrusions therein. The secure fit achieved thereby ensures that the panel stringer cannot accidentally be detached from the supporting arm of the pedestal.

[0008] The cavities and protrusions are advantageously arranged with slight play therebetween, so as to permit adaptation of the support structure to minor movement of the base floor.

[0009] The guides advantageously have a cross-section narrowing in direction of the cavities. This allows easy and fast alignment of the protrusions with the grooves, through which the protrusions are automatically led to the cavities.

[0010] The cross-section of the guides, in proximity to said cavities, is preferably slightly smaller than the cross-section of said protrusions. The latter must hence be forced through the narrower portions of the guides in order to reach the cavities. This means that, once the protrusions are received in the cavities, a secure connection is achieved. The protrusions cannot easily escape from

the cavities unless sufficient force is applied in order to push the protrusions through the narrower portions of the guides. Accidental uncoupling of the panel stringers from the supporting arms is thereby prevented and an improved support structure is achieved.

[0011] The protrusions can e.g. be rounded for easier and faster connection of the panel stringer to the supporting arm.

[0012] According to one embodiment, the supporting head of the pedestal has four supporting arms arranged at right angles to each other. The supporting arms can have a panel stringer coupled thereto, thereby forming a rectangular grid on which the floor panels of the elevated floor assembly can rest.

[0013] According to a preferred embodiment, the supporting head of the pedestal has four main supporting arms arranged at right angles to each other and four auxiliary supporting arms arranged at right angles to each other and at 45° with respect to the main supporting arms. The main supporting arms can have a panel stringer coupled thereto, thereby forming a square grid on which the floor panels of the elevated floor assembly can rest. Due to the auxiliary supporting arms, further panel stringers can be arranged diagonally through the squares of the grid, thereby providing further support to the floor panels. At the edges of the elevated floor, stringer members are often shortened onsite to accommodate narrower floor panels. By designing the auxiliary supporting arms without lateral protrusions, a cut end of the stringer member, i.e. an end of the stringer member without corresponding cavities, can be connected to the auxiliary supporting arm. This has the advantage that no other pedestals have to be provided for use at the edges of the elevated floor. Rather, the same pedestals can simply be turned by about 45 degrees and used to support shortened stringer members and floor panels.

[0014] The auxiliary supporting arms are preferably longer than the main supporting arms. This allows the panel stringers coupled to the main supporting arms to be coupled as close as possible to the centre of the pedestal. The closer the coupling is made to the centre of the supporting head, the more stable the support structure becomes. When seen from above, the supporting head is preferably generally square.

[0015] Furthermore, the supporting arms of the pedestals and the interconnecting portion of the panel stringers can comprise holes, the holes being arranged so as to be in alignment when the panel stringer is coupled to the pedestal. If desired, the coupling between panel stringer and pedestal can then be complemented by additional fixing means such as e.g. screws, nails or rivets through the bores.

Detailed description with respect to the figures

[0016] The present invention will be more apparent from the following description of a not limiting embodiment with reference to the attached drawings, wherein

Fig.1 is a side view of a pedestal and an end portion of a panel stringer of a support structure for an elevated floor assembly;

5 Fig.2 is a schematic top view of a supporting head of a pedestal according to the present invention; and

10 Fig.3 is a schematic perspective view of an end portion of a panel stringer according to the present invention;

[0017] Fig.1 shows a pedestal 10, which is mounted on a base floor 12 to form a support structure together with panel stringers 14, only one of which is partially shown. The pedestal 10 comprises a column, which is globally identified with reference number 16, a supporting head 17 fixed to the upper end of the column 16, and a base plate 18 fixed to the lower end of the column 16. The column 16 consists of a threaded rod 20, a bearing nut 22 screwed on the threaded rod 20 and a hollow support tube 24. The lower end of the support tube 24 is placed over the upper end of the threaded rod 20 and supported thereon by the bearing nut 22. It follows that the support tube 24 can be raised or lowered by screwing the bearing nut 22 on the threaded rod 20, so that the height of the pedestal 10 can be freely adjusted. The upper end of the support tube 24 is connected to the supporting head 17. The latter includes normally four or eight supporting arms to which the panel stringers 14 are coupled. On Figure 1 only two supporting arms 26, 26' are seen. The floor panels, which rest on the panel stringers 14, are not shown on Figure 1.

[0018] A top view of a supporting head 17 of a pedestal 10 is schematically shown in Fig.2. The shown supporting head 17 comprises four main supporting arms 26, 26', 26", 26''' arranged at right angles to each other and four auxiliary supporting arms 28, 28', 28", 28''' arranged at right angles to each other and at 45° with respect to the main supporting arms 26, 26', 26", 26'''. By coupling panel stringers 14 to the main supporting arms 26, a square grid is formed, on which floor panels of the elevated floor assembly can rest. Further panel stringers can be coupled to the auxiliary supporting arms 28 and diagonally arranged through the squares of the grid. This allows providing further support for the floor panels. Only one 26 of the main supporting arms 26, 26', 26", 26''' will now be described in more detail.

[0019] The supporting arm 26 extends radially outwards, from the centre of the supporting head 17 and laterally comprises two generally rounded protrusions 30, 30'. The shape and size of the protrusions 30, 30' is adapted to cooperate with two cavities arranged in the panel stringer as will be described below. The supporting arm 26 can further comprise a hole 32 adapted to cooperate with a hole arranged in the panel stringer as will also be described below.

[0020] As can be seen on Fig.2, the supporting head 17 is preferably generally square when seen from above.

The auxiliary supporting arms 28, 28', 28'', 28''' are longer than the main supporting arms 26, 26', 26'', 26'''. This allows the panel stringers coupled to the main supporting arms to be coupled as close as possible to the axis of the pedestal, thereby achieving a more stable support structure. It can also be seen on Fig.2 that the auxiliary supporting arms 28, 28', 28'', 28''' are not provided with protrusions. It is however not excluded to provide all eight supporting arms with protrusions.

[0021] A simplified perspective view of an end portion of a panel stringer 14 is shown in Fig.3. The panel stringer 14 has a generally inverted U-shaped cross-section and comprises two generally parallel side portions 34, 34' and an interconnecting portion 36. The corners 38, 38' of the side portions remote from the interconnecting portion 36 are preferably bevelled in order to facilitate the coupling of the panel stringer 14 to the supporting head 17 of the pedestal 10.

[0022] The side portions 34, 34' of the panel stringer 14 further comprise indentations on the inner surfaces 40, 40' of the respective side portions 34, 34'. The indentations are such as to form cavities 42, 42' and guides 44, 44' leading from the bevelled corners 38, 38' of the side portions 34, 34' to the cavities 42, 42'.

[0023] The cavities 42, 42' are dimensioned so as to receive the protrusions 30, 30' of the supporting arm 26. Preferably, the cavities 42, 42' are dimensioned so as to securely receive the protrusions 30, 30' therein, so that a secure fit between panel stringer and pedestal can be achieved. This ensures that the panel stringer cannot be accidentally detached from the supporting arm of the pedestal. The cavities 42, 42' and protrusions 30, 30' are further arranged with slight play therebetween, so as to permit adaptation of the support structure to minor movement of the base floor. The guides 44, 44' have a cross-section narrowing in direction of the cavities 42, 42'. The cross-section of the guides 44, 44' at the bevelled corners 38, 38' is bigger than that of the protrusions 30, 30', thereby allowing easy engagement of the protrusions 30, 30' in the guides 44, 44'. Once the protrusions 30, 30' are engaged in the guides 44, 44', the panel stringer 14 is pushed down onto the supporting arm 26 of the pedestal 10. The protrusions 30, 30' are thereby guided towards the cavities 42, 42'.

[0024] The cross-section of the guides 44, 44' near the cavities 42, 42' is slightly smaller than that of the protrusions 30, 30'. This means that the protrusions 30, 30' have to be forced through the guides 44, 44' in order to reach the cavities 42, 42'. This however also means that once the protrusions 30, 30' have reached the cavities 42, 42', they cannot easily escape therefrom. Accidental uncoupling of the panel stringers 14 from the pedestals 10 is thereby prevented.

[0025] Due to the protrusions 30, 30' and the cavities 42, 42', the panel stringers 14 are prevented from sliding on the supporting arms 26 and are always positioned correctly with respect to the pedestal. Correct coupling of the panel stringers 14 to the pedestals 10 is therefore

always ensured and the correct distance between adjacent pedestals is also respected.

[0026] The interconnecting portion 36 of the panel stringer 14 further comprises a hole 46 arranged so as to cooperate with the hole 32 of the supporting arm 26 when the panel stringer 14 is coupled to the supporting head 17 of the pedestal 17. The coupling between panel stringer 14 and pedestal 10 can then, if desired, be complemented by additional fixing means such as e.g. screws, nails or rivets through the bores 32, 46.

[0027] It will be understood that, in order to simplify the figures, the side portions and the interconnecting portion of the panel stringer shown in the present application are substantially flat. Generally however they comprise longitudinal reinforcing ribs to confer further strength to the panel stringer. Also, the supporting arms 26, 28 of the supporting head 17 are then generally shaped so as to correspond to the shape of the interconnecting portion of the panel stringer.

Claims

1. Support structure for elevated floor assembly comprising a plurality of pedestals (10) and panel stringers (14) coupled between adjacent pedestals (10), each pedestal (10) having a column (16) with a supporting head (17) on an upper end of said column (16) and a plate (18) on the lower end of said column (18), said supporting head (17) having radially protruding supporting arms (26) for connecting said panel stringers (14) thereto, each panel stringer (14) having a generally inverted U-shaped cross-section with two generally parallel side portions (34, 34') and an interconnecting portion (36), wherein the interconnecting portion (36) rests on the radially protruding supporting arm (26) of the supporting head (17) of the pedestal (10), said side portions having an inner surface (40, 40') wherein at an end portion of said panel stringer (14), at least one of said side portions (34, 34') comprises a cavity (42, 42') proximate said interconnecting portion (36) and a guide (44, 44') leading from an edge of the side portion (34, 34') remote from said interconnecting portion (36) to said cavity (42, 42'), and wherein said supporting arm (26) comprises at least one lateral protrusion (30, 30') configured to be received in said cavity (42, 42') when said panel stringer (14) is connected to said supporting arm (26) of said pedestal (10) **characterized in that** said cavity (42, 42') and said guide (44, 44') are formed by an indentation on said inner surface (40, 40'), said guide (44, 44') extending from an edge of the side portion (34, 34') into said cavity (42, 42').
2. Support structure according to claim 1, wherein said cavities (42, 42') are dimensioned so as to securely

receive said protrusions (30, 30') therein with play sufficient to permit adaptation of the support.

3. Support structure according to claim 1 or 2, wherein said cavities (42, 42') and said protrusions (30, 30') are arranged with slight play therebetween. 5
4. Support structure according to any of claims 1 to 3, wherein said guides (44, 44') have a cross-section narrowing in direction of said cavities (42, 42'). 10
5. Support structure according to claim 4, wherein the cross-section of said guides (44, 44'), in proximity to said cavities (42, 42'), is slightly smaller than the cross-section of said protrusions (30, 30'). 15
6. Support structure according to any of claims 1 to 5, wherein said protrusions (30, 30') are rounded.
7. Support structure according to any of claims 1 to 6, wherein said supporting head (17) of said pedestal (10) has four supporting arms (26, 26', 26", 26''') arranged at right angles to each other. 20
8. Support structure according to any of claims 1 to 6, wherein said supporting head (17) of said pedestal (10) has four main supporting arms (26, 26', 26", 26''') arranged at right angles to each other and four auxiliary supporting arms (28, 28', 28", 28''') arranged at right angles to each other and at 45° with respect to said main supporting arms (26, 26', 26", 26'''). 25
9. Support structure according to claim 8, wherein said auxiliary supporting arms (28, 28', 28", 28''') are longer than said main supporting arms (26, 26', 26", 26'''). 30
10. Support structure according to any of claim 1 to 9, wherein said supporting arms (26, 28) of said pedestals (10) and said interconnecting portion (36) of said panel stringers (14) comprise holes (32, 46), said holes (32, 46) being arranged so as to be in alignment when said panel stringer (14) is coupled to said pedestal (10). 35

Patentansprüche

1. Stützstruktur für eine aufgeständerte Fußbodenanordnung, umfassend mehrere Stützfüße (10) und Plattenlängsträger (14), die zwischen benachbarten Stützfüßen (10) verbunden sind, wobei jeder Stützfuß (10) einen Stab (16) mit einem Stützkopf (17) an einem oberen Ende des Stabs (16) und eine Platte (18) am unteren Ende des Stabs (16) aufweist, wobei der Stützkopf (17) radial hervorste- hende Stützarme (26) aufweist, um die Plattenlängs- träger (14) daran zu verbinden, 40

wobei jeder Plattenlängsträger (14) einen generell wie ein umgekehrtes U geformten Querschnitt mit zwei generell parallelen Seitenabschnitten (34, 34') und einem verbindenden Abschnitt (36) aufweist, wobei der verbindende Abschnitt (36) auf dem radial hervorstehenden Stützarm (26) des Stützkopfs (17) des Stützfußes (10) aufliegt, wobei die Seitenab- schnitte eine Innenfläche (40, 40') aufweisen, wobei an einem Endabschnitt des Plattenlängsträ- gers (14) mindestens einer der Seitenabschnitte (34, 34') eine Aussparung (42, 42') nahe dem verbindenden Abschnitt (36) und eine Führung (44, 44') um- fasst, die von einer dem verbindenden Abschnitt (36) fernen Kante des Seitenabschnitts (34, 34') zur Aus- sparung (42, 42') führt, und wobei der Stützarm (26) mindestens einen seitlichen Vorsprung (30, 30') umfasst, der so konfiguriert ist, dass er in der Aussparung (42, 42') aufgenommen ist, wenn der Plattenlängsträger (14) mit dem Stütz- arm (26) des Stützfußes (10) verbunden ist, **dadurch gekennzeichnet, dass** die Aussparung (42, 42') und die Führung (44, 44') durch eine Vertiefung an der Innenfläche (40, 40') ausgebildet sind, wobei die Führung (44, 44') sich von einer Kante des Seitenabschnitts (34, 34') in die Aussparung (42, 42') erstreckt

2. Stützstruktur nach Anspruch 1, wobei die Aus- sparungen (42, 42') so bemessen sind, dass sie die Vor- sprünge (30, 30') sicher darin mit einem Spiel auf- nehmen, das ausreicht, um eine Anpassung der Stütze zu erlauben.
3. Stützstruktur nach Anspruch 1 oder 2, wobei die Aus- sparungen (42, 42') und die Vorsprünge (30, 30') mit leichtem Spiel dazwischen angeordnet sind
4. Stützstruktur nach irgendeinem der Ansprüche 1 bis 3, wobei die Führungen (44, 44') einen Querschnitt aufweisen, der in Richtung der Aussparungen (42, 42') schmaler wird
5. Stützstruktur nach Anspruch 4, wobei der Quer- schnitt der Führungen (44, 44') in der Nähe der Aus- sparungen (42, 42') etwas kleiner als der Querschnitt der Vorsprünge (30, 30') ist
6. Stützstruktur nach irgendeinem der Ansprüche 1 bis 5, wobei die Vorsprünge (30, 30') gerundet sind.
7. Stützstruktur nach irgendeinem der Ansprüche 1 bis 6, wobei der Stützkopf (17) des Stützfußes (10) vier Stützarme (26, 26', 26", 26''') aufweist, die in rechten Winkeln zueinander angeordnet sind
8. Stützstruktur nach irgendeinem der Ansprüche 1 bis 6, wobei der Stützkopf (17) des Stützfußes (10) vier Hauptstützarme (26, 26', 26", 26'''), die in rechten

Winkeln zueinander angeordnet sind, und vier Zusatzstützarme (28, 28', 28", 28'''), die in rechten Winkeln zueinander und bei 45° in Bezug auf die Hauptstützarme (26, 26', 26", 26''') angeordnet sind, aufweist.

9. Stützstruktur nach Anspruch 8, wobei die Zusatzstützarme (28, 28', 28", 28''') länger als die Hauptstützarme (26, 26', 26", 26''') sind.
10. Stützstruktur nach irgendeinem der Ansprüche 1 bis 9, wobei die Stützarme (26, 28) der Stützfüße (10) und der verbindende Abschnitt (36) der Plattenlängsträger (14) Löcher (32, 46) umfassen, wobei die Löcher (32, 46) so angeordnet sind, dass sie ausgerichtet sind, wenn der Plattenlängsträger (14) mit dem Stützfuß (10) verbunden ist

Revendications

1. Structure de support pour ensemble de plancher surélevé comprenant une pluralité de piédestaux (10) et de longrines de panneaux (14) couplées entre piédestaux (10) adjacents, chaque piédestal (10) ayant une colonne (16) avec une tête de support (17) sur une extrémité supérieure de ladite colonne (16) et une plaque (18) sur l'extrémité inférieure de ladite colonne (16), ladite tête de support (17) ayant des bras de support (26) faisant saillie radialement pour connecter lesdites longrines de panneaux (14) à celle-ci, chaque longrine de panneaux (14) ayant une section transversale de façon générale en forme de U inversé avec deux parties latérales (34, 34') de façon générale parallèles et une partie d'interconnexion (36), dans laquelle la partie d'interconnexion (36) repose sur les bras de support (26) faisant saillie radialement de la tête de support (17) du piédestal (10), lesdites parties latérales ayant une surface intérieure (40, 40'), dans laquelle au niveau d'une partie d'extrémité de ladite longrine de panneaux (14), au moins l'une desdites parties latérales (34, 34') comprend une cavité (42, 42') à proximité de ladite partie d'interconnexion (36) et un guide (44, 44') menant d'un bord de la partie latérale (34, 34') distante de ladite partie d'interconnexion (36) jusqu'à ladite cavité (42, 42'), et dans laquelle ledit bras de support (26) comprend au moins une saillie latérale (30, 30') configurée pour être reçue dans ladite cavité (42, 42') lorsque ladite longrine de panneaux (14) est connectée audit bras de support (26) dudit piédestal (10)
- caractérisée en ce que** ladite cavité (42, 42') et ledit guide (44, 44') sont formés par une indentation sur ladite surface intérieure (40, 40'), ledit guide (44, 44') s'étendant à partir d'un bord de la partie latérale (34, 34') à l'intérieur de la-

dite cavité (42, 42').

2. Structure de support selon la revendication 1, dans laquelle lesdites cavités (42, 42') sont dimensionnées de façon à recevoir solidement lesdites saillies (30, 30') dans celles-ci avec un jeu suffisant pour permettre une adaptation du support.
3. Structure de support selon la revendication 1 ou 2, dans laquelle lesdites cavités (42, 42') et lesdites saillies (30, 30') sont agencées avec un léger jeu entre celles-ci
4. Structure de support selon l'une quelconque des revendications 1 à 3, dans laquelle lesdits guides (44, 44') ont une section transversale se rétrécissant dans la direction desdites cavités (42, 42')
5. Structure de support selon la revendication 4, dans laquelle la section transversale desdits guides (44, 44'), à proximité desdites cavités (42, 42'), est légèrement plus petite que la section transversale desdites saillies (30, 30')
6. Structure de support selon l'une quelconque des revendications 1 à 5, dans laquelle lesdites saillies (30, 30') sont arrondies,
7. Structure de support selon l'une quelconque des revendications 1 à 6, dans laquelle ladite tête de support (17) dudit piédestal (10) a quatre bras de support (26, 26', 26", 26''') agencés à angle droit les uns par rapport aux autres.
8. Structure de support selon l'une quelconque des revendications 1 à 6, dans laquelle ladite tête de support (17) dudit piédestal (10) a quatre bras de support principaux (26, 26', 26", 26''') agencés à angle droit les uns par rapport aux autres et quatre bras de support auxiliaires (28, 28', 28", 28''') agencés à angle droit les uns par rapport aux autres et à 45° par rapport auxdits bras de support principaux (26, 26', 26", 26''')
9. Structure de support selon la revendication 8, dans laquelle lesdits bras de support auxiliaires (28, 28', 28", 28''') sont plus longs que lesdits bras de support principaux (26, 26', 26", 26''').
10. Structure de support selon l'une quelconque des revendications 1 à 9, dans laquelle lesdits bras de support (26, 28) desdits piédestaux (10) et ladite partie d'interconnexion (36) desdites longrines de panneaux (14) comprennent des trous (32, 46), lesdits trous (32, 46) étant agencés de façon à être en alignement lorsque ladite longrine de panneaux (14) est couplée audit piédestal (10)

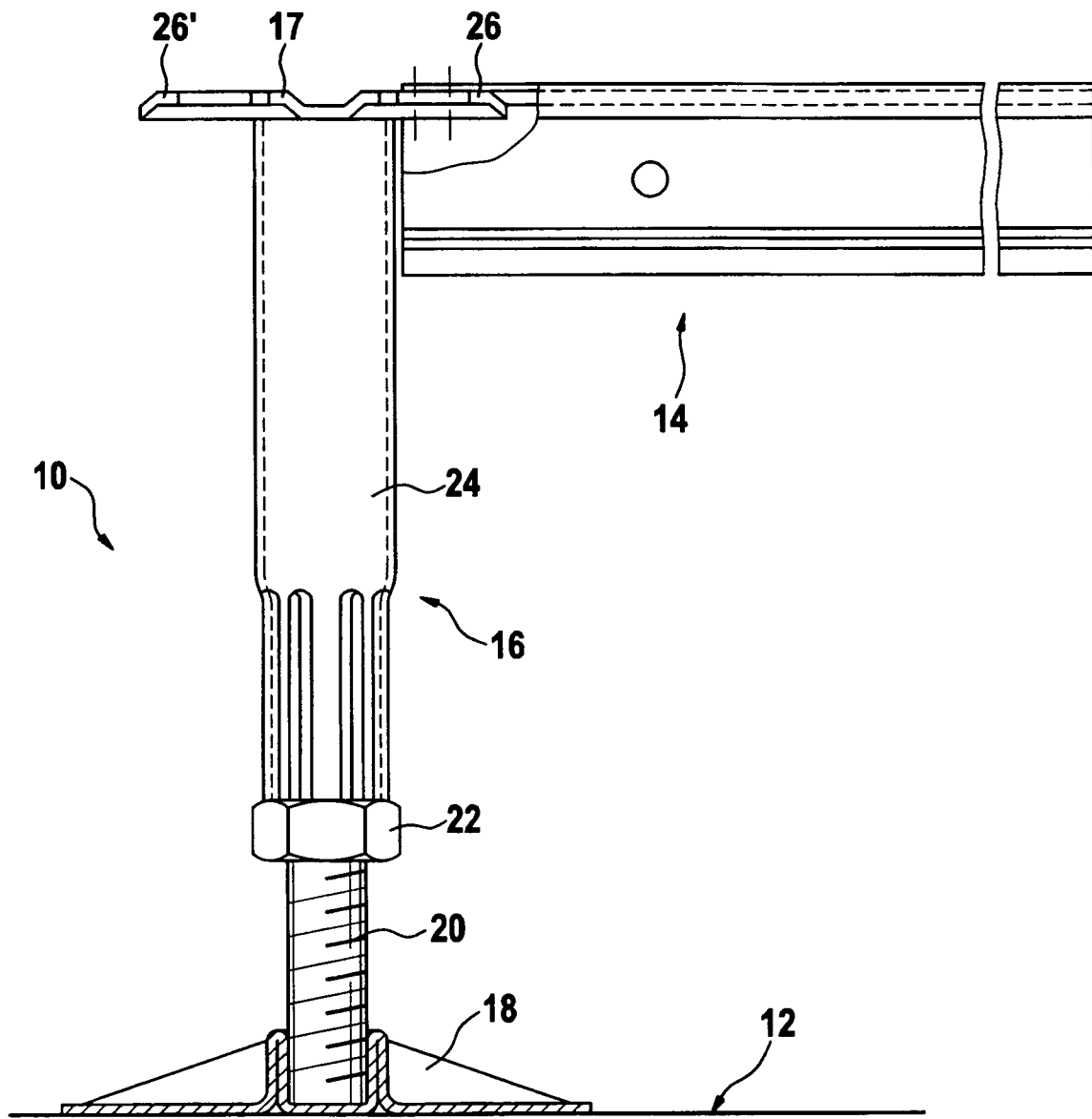
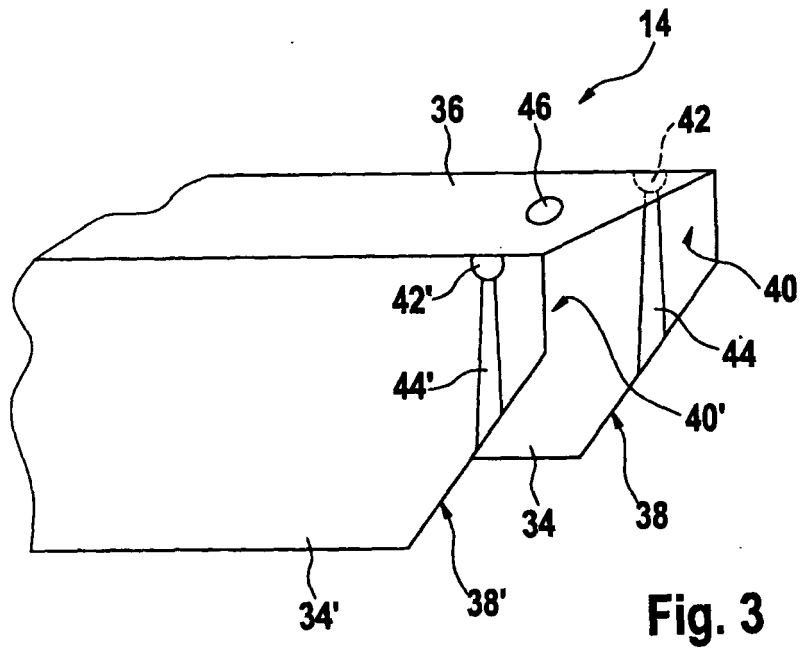
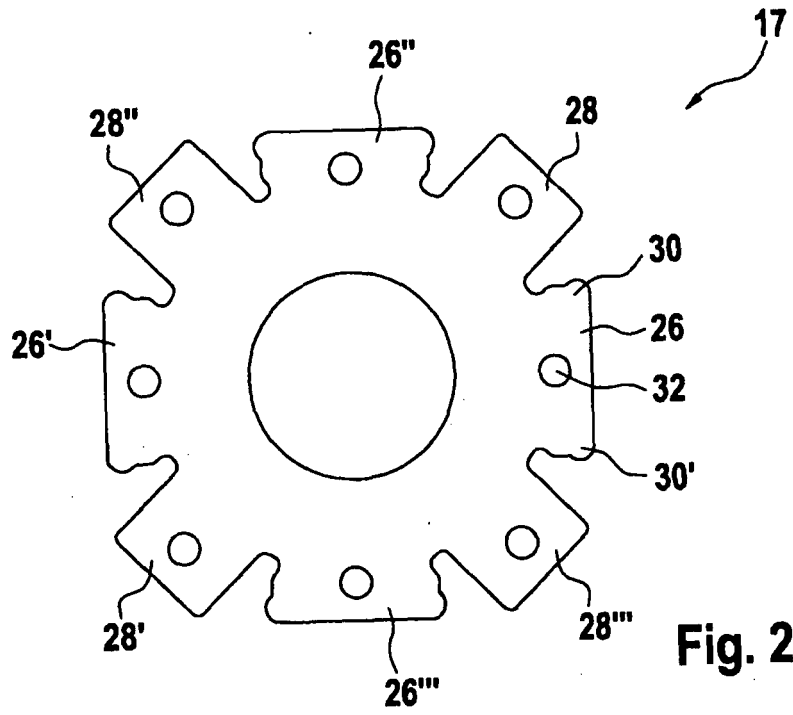

Fig. 1



REFERENCES CITED IN THE DESCRIPTION

This list of references cited by the applicant is for the reader's convenience only. It does not form part of the European patent document. Even though great care has been taken in compiling the references, errors or omissions cannot be excluded and the EPO disclaims all liability in this regard.

Patent documents cited in the description

- US 4277923 A [0003]
- EP 1247922 A [0004]