



(11) **EP 1 864 914 A1**

(12) **EUROPEAN PATENT APPLICATION**

(43) Date of publication:
12.12.2007 Bulletin 2007/50

(51) Int Cl.:
B65D 21/02 (2006.01) **B65D 43/02 (2006.01)**
B65D 51/24 (2006.01)

(21) Application number: **07109447.8**

(22) Date of filing: **01.06.2007**

(84) Designated Contracting States:
AT BE BG CH CY CZ DE DK EE ES FI FR GB GR HU IE IS IT LI LT LU LV MC MT NL PL PT RO SE SI SK TR
Designated Extension States:
AL BA HR MK YU

(72) Inventors:
• **Luttik, Nicolaas**
4101 WL, Culemborg (NL)
• **Hageman, Robert Johan Joseph**
6705 CT, Wageningen (NL)

(30) Priority: **09.06.2006 EP 06115219**

(74) Representative: **van Westenbrugge, Andries**
Nederlandsch Octrooibureau
Postbus 29720
2502 LS Den Haag (NL)

(71) Applicant: **N.V. Nutricia**
2712 HM Zoetermeer (NL)

(54) **Container assembly having stacking means**

(57) Container assembly (1) comprising a container part (3) and a lid part (2). The lid part has a connection portion (8) to be connected to said container part. For automatic assembly of the container assembly from the container part and the lid part it is advantageous that separate lid parts can be manipulated easily. To that end it is proposed to embody the lid parts such a way that they are stackable in a stable way. More particular it is proposed to provide the top side of the lid with a circumferential cam (9) which can engage inside a circumferential rim (22) of the connection portion. To be able to remove dust and debris from the top side of the lid it is proposed to provide a circumferential cam with interruptions (10). In the embodiment wherein part of the lid is shaped to correspond with its aimed contents, as is for example part of the spoon, the interruption should preferably be provided at the location of such shape such as a spoon. If the container assembly is rectangular such shapes preferably extend diagonally and the interruptions are also provided diagonally. In this way a very stable stacking position is obtained. The cam on the lid is preferably embodied to also be engagable with the circumferential edge of the bottom of a further container so that a number of containers can be stacked in a stable way.

Fig 1

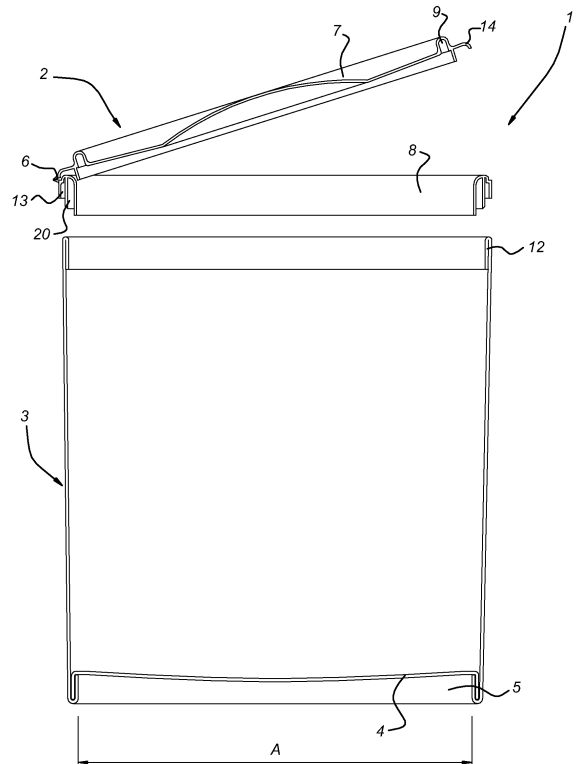

EP 1 864 914 A1

Description

Background

[0001] The present invention relates to a container assembly comprising a container part and a lid part, said lid part comprising a connection portion for connection to said container part and a lid being pivotably connected to said connection portion. The invention further relates to such a lid part.

[0002] Such a container assembly and lid part are known from PCT/NL 2005/000089, which is incorporated by reference as if fully set forth. A package is disclosed therein for containing both a product and a spoon. Subject invention can be used in combination with such a package but it should be noted that it can also be used with other prior art packages.

[0003] Such a container assembly is produced by combining the container part with the lid part. More particular the connection portion of the lid part is adhered to the top side of the container. It is aimed to optimize the assembly of the lid part and container part as much as possible. To that end lid parts should be automatically supplied and manipulated to be brought in position on the container part. Exact positioning of the lid part is essential.

[0004] Other container assemblies having a container part and a lid part with a lid which is pivotably connected to a connection portion are shown in FR-2.747.107, US-5.705.212, JP-2001019006, JP-2000344243, FR 1.338.551, US-6.604.645, DE-19815364, CH-381606, CH-671749, EP-1157936, GB-2.250.271, US-5.219.087. automatically supplying the lid parts, automatically manipulating the lid parts and placing them on the container parts is a problem, especially when high production speeds are desired.

Summary of the invention

[0005] The invention aims to improve handling of the lid parts in order to more easily assemble lid part and container part.

[0006] Another object of the invention is to improve the handling of the container with the lid part and container part attached to it.

[0007] Yet another object of the invention is to provide the improvements without deteriorating other beneficial properties of the container assembly.

[0008] According to a first aspect of the invention this is realized with a container assembly as described above in that the side remote from said lid of said connection portion and the side from the lid remote from the connection portion are provided with first complementary stacking means. According to the invention a stable stack of lid parts is obtained by the complementary cooperating stacking means provided both on the top and lower side of each lid part.

[0009] This provides the possibility of stacking lid parts

during manufacturing in a stable and well-defined way, allowing improved automatic handling. Furthermore, as will be explained, it allows stable stacking of container assemblies on top of one another. Additionally, it allows at the same time an improved stability and rigidity of the lid and improved handling during use, in particular during opening and closing of the lid.

[0010] Such complementary stacking means according to the first aspect of the invention can comprise any structure of complementary interengaging means. However, preferably according to a further aspect of the invention the complementary stacking means comprise a cam-recess. The cam should be positioned in the recess after which a stable stack of lid parts is obtained. From such stable stack with a robot arm lid parts can be taken to be placed on the container part during manufacturing of the container assemblies.

[0011] The cam can be provided both on the side of the lid facing away from the connection portion or in the connection portion. However, it is preferred that the cam is provided in the top of the lid. In this way basically the connection portion can be produced without too many special measures taken for receiving the cam of the adjacent lid part. In most cases the circumferential rim of the connection portion will be sufficient to receive the cam of the next adjacent lid.

[0012] According to a further preferred embodiment of the invention complementary stacking means are also provided between the top of the lid and the bottom of the container part. In this way assembled (and filled) container assemblies can be stacked on top of each other during shipping and display for the consumer. Also these complementary stacking means are preferably provided such that the lid has a cam whilst the bottom of the container part is provided with a corresponding accommodation. Preferably such accommodation is delimited by the circumferential rim of the bottom of the container which is preferably made from the outer wall of the container together with part of the bottom thereof.

[0013] More particularly, it is preferred that the cam on top of the lid both functions as complementary stacking means for further lid parts during assembly and as complementary stacking means during stacking of the container assemblies. In this way only a single cam will suffice.

[0014] According to a further aspect of the invention the cam is a circumferential cam extending near the outer circumference of the lid to provide maximum stability during stacking. Preferably such a circumferential cam has interruptions to be able to clean the top of the lid by whipping away debris and the like.

[0015] In an embodiment of the invention, the complementary stacking means comprise a rim extending from the upper part of the lid (in other words, the side of the lid remote from the connection part), said rim providing a first abutment against sliding in a direction substantially in the lid's plane. In this embodiment, the lid furthermore preferably has a second abutment contiguous to rim, pro-

vided by the surface of the lid adjacent to the rim.

[0016] In this embodiment, the container part at its bottom side has a rim, which has dimensions adapted to the dimensions of the rim on the lid in such a way so as to work together with the rim on the lid to provide complementary stacking means which prevent a first container assembly which is placed on top of a second container assembly, i.e. with its bottom on the lid of the second container, from sliding.

[0017] Furthermore, in an embodiment, the connection portion at its side remote from the lid of the connection portion has a rim for providing a first abutment in a direction substantially in the lid's plan for providing an abutment against the first abutment of the rim on the lid. Furthermore, this rim on the connection portion can have a second abutment for providing an abutment against the second abutment contiguous to rim on the lid, i.e. the second abutment provided by the surface of the lid adjacent the rim. In an embodiment, this rim on the connection portion is a circumferential rim. In an embodiment, it is a U-shaped ring providing additional strength to the connection portion, said U-shaped ring opening to the side of the connection portion remote from the lid.

[0018] In an embodiment, the rim on the lid provides several abutments at several positions of the circumference of the lid.

[0019] In an embodiment, the rim comprises outward extending lid material. Said rim can be formed by bulging lid-material out from the main surface of the lid in the direction away from the connection portion.

[0020] In an embodiment, the lid comprises at least two rim portions providing an abutment extending over at least part of at least three sides of the container assembly when having a rectangular cross-section (or it has at least three abutments spread around the circumference of the lid).

[0021] In an embodiment in which the container has four sides, there is providing an abutment for four sides.

[0022] In an embodiment, at least two rim portions circumscribe more than 50 % of the circumference of the lid.

[0023] According to a further aspect of the invention the top of the lid is at least partially shaped to conform a spoon which could be accommodated inside the lid. To that end the inside of the lid is provided with clamping means for clampingly engaging a (metering) spoon. The top of the lid has a (partially) corresponding shape. If the container assembly is relatively high a relatively long spoon is required to remove the contents from the container. If the container is furthermore a rectangular container it is preferred to use the full length of the diagonal of the lid for receiving such a spoon. According to a preferred embodiment of the invention interruptions of the circumferential cam on top of the lid are at the position of the shape for the spoon.

[0024] According to a further preferred embodiment the lid is smooth at the location of the interruption to provide easy removal of debris.

[0025] The invention relates to any shape of the con-

tainer. If the container is a rectangular container preferably the corners thereof are rounded. Furthermore between the corner the sides are preferably bulging outwardly giving a more aesthetic shape. Furthermore, this will increase the internal volume of the container, or lower its height with the same volume. Thus, the spoon can be made shorter, or it is easier to empty the container using the same spoon length.

[0026] The invention also relates to a lid part as described above.

[0027] The invention further relates to a container assembly comprising a container part and a lid part, said lid part comprising a connection portion for connection to said container part, a lid being pivotably connected to said connection portion, and a locking means for locking said lid to said connection portion, wherein said locking means comprises a lip on said lid which has an upper lip part extending above a lid surface away from said connection portion and a lower lip part extending adjacent to said connecting portion, said lip being tiltable with respect to said lid about an axis substantially in a plane of said lid and near an edge of said lid.

[0028] According to an aspect of this further invention, this container assembly has said locking lip connected to said lid via an at least partly thinned portion of said lid, in an embodiment a part of the portion of the lid connecting the locking lip is taken away.

[0029] The invention further relates to a container assembly comprising a container part and a lid part, said lid part comprising a connection portion for connection to said container part, a lid being pivotably connected to said connection portion, and a locking means for locking said lid to said connection portion, wherein said lid comprising a lip for locking said lid to said connection portion, said lip being operably connected to said lid and having a cam and said connecting portion having a further cam, both cams positioned for engaging one another to keep said lid onto said connecting portion when said lip is not operated and to disengage one another when said lip is operated, and said connection portion further comprises a security lip positioned over said lip for preventing operation of said locking lip and providing temper evidence.

[0030] In an embodiment of this aspect of the invention, this container has said security lip connected to said connecting portion adjacent to both sides of said locking lip, and is connected to said connecting portion adjacent to an end of said locking lip via connecting bridges.

[0031] The invention further relates to a container assembly comprising a container part and a lid part, said lid part comprising a connection portion for connection to said container part and a lid being pivotably connected to said connection portion, wherein said lid comprising a lip for locking said lid to said connection portion, said lip being operably connected to said lid and having a cam and said connecting portion having a further cam, both cams positioned for engaging one another to keep said lid locked onto said connecting portion when said lip is not operated and to disengage one another when said

lip is operated, said lid further having a gripping area adjacent said lip for arrangement of a finger or thumb of a user when operating said lip.

[0032] In an embodiment of this aspect of the invention, this container assembly has said lid comprising a rim adjacent to said gripping area and having a rim wall extending to said gripping area.

[0033] In an aspect of this invention, said gripping area comprises a local depression or recess in said lid.

[0034] In an embodiment, said depression has a wall running downward from the wall of the rim.

[0035] The lid part described above is preferably injection moulded as one part, in particular injection moulded from PE, PP, or other synthetic materials suitable for injection moulding.

[0036] The various aspects discussed in this patent can be combined in order to provide additional advantageous advantages.

Description of the drawings

[0037] The invention will be further elucidated referring to an preferred embodiment shown in the drawing wherein shown in:

Fig. 1 in exploded view a container assembly according to the invention;

fig. 2 the container assembly according to fig. 1 after assembly;

fig. 3 a stack of lid parts before assembly with the container part;

fig. 4 a perspective top and side view of a lid part according to the invention;

fig. 5 a perspective bottom and side view of the lid part of fig. 4;

fig. 6 a cross section of fig. 4,

fig. 7 the lid part of fig. 4 opened, i.e., with the lid hinged open with respect to the connection portion,

fig. 8 an alternative lid-shape.

Detailed description of embodiments

[0038] In the figures the container assembly is referred to by 1. It comprises a lid part 2 and a container part 3. Container part 3 is provided with a bottom 4 and the bottom material is connected to the side walls and defines a circumferential rim 5. The container part can be made of cardboard, coated with a synthetic coating layer known in the art for making it suitable for containing food or liquids. The container part can also be made of plastic or metal, preferably for holding food or liquids.

[0039] Lid part 2 comprises a connection portion 8, a (living) hinge 6 and a lid 7. Lid 7 is pivotably connected to connection portion 8. Connection portion 8 comprises a circumferential U-shaped rim 13 to receive the upper edge 12 of the side wall of the container part 3. Fixation of the connection portion 8 to the container wall can be effected through any means known in the art. In these

drawings, the upper edge 12 of the container part 3 is folded and thus forms a double material layer. In practise, however, this needs not be the case and in most case it is a single layer.

[0040] According to the invention the top of lid 7 is provided with a circumferential cam. In the embodiment shown in the drawings the lid has two cam portions 9 having interruptions 10 (Fig. 4) between them. In the embodiment shown, the cams are parts of the lid 7 bulging out (i.e., away from connection portion 8). It is also conceivable to provide a rim on top of the lid 7. It may even be conceivable to make the cam (circumferentially) bulging in, i.e. towards connection portion 8. It than in fact forms a groove. In that case rim 5 at the bottom of container part 3 is received within this groove.

[0041] The top of the lid 7 is shaped to partially correspond with the shape of a spoon. The shape is indicated by 11 (fig. 4, 5). Inside the lid 7 clamping means (fig 5, nr 29) are provided to accommodate and hold a spoon having the shape and size of shape 11 of the spoon (not shown). From fig. 4 it is clear that the lid is substantially rectangular and shape 11 is position diagonally. Interruptions 10 of the cam portions 9 are at the position where it "crosses" shape 11. Preferably about 20% of the circumference at the position of cams 9 comprises interruptions 10.

[0042] The lid is further provided with a circumferential rim 14 which in the closed position covers at least the top of the connection portion 8. Cooperating locking means 31 are provided to lock the lid relative to the connection portion and tamper evident means 30 can be provided over the locking means 31 to prevent abuse. In this embodiment, locking means 31 comprise a lip 31 on lid 7 with a cam on its side directed toward the lid 7, and a cam on connecting portion 8. These two cams engage one another the lid 7 is closed and the locking lip 31 is not operated and disengage when the locking lip 31 is operated, allowing a user to open the lid 7. In this embodiment, the locking lip 31 is tiltably connected to lid 7, and is tiltable around an axis in the main plane of the lid 7 and near the boundary of the lid 7. To that end, the lip 31 is connected to the lid 7 via a thinned part 26 of the lid (see fig. 6). In case the locking lip 31 extends above the main surface 22 of the lid 7, as is the case in the embodiment shown here, it proved (part of) gripping means via which a user can grip the lid 7 for opening it.

[0043] At the position of the locking lip 31 a gripping area 28 is provided. In this embodiment, it is created by providing a (local) recess 28 in the lid, and by providing cam 9 in such a way that the inner wall 33 of this cam 9 runs on into a wall of recess 28. In this way, a relatively large plane 33 is created onto which a finger or thumb can rest when operating locking lip 31 with another finger/thumb.

[0044] In fig. 6 it is further indicated that cam 9 has a top 24 which, as already mentioned, extends about 5-7 mm above the surface 22 defined by rim 14, which substantially defines the plane of the lid 7. Wall 25 is the

outer wall of cam 9. Locking lip 31 does not extend above this cam in order not to compromise the stackability of lid parts and/or container assemblies.

[0045] Tamper evidence means 30 is in this embodiment comprises a lip 30 which is connected to the connecting portion 8 via thin connecting bridges. These bridges are provided near both sides of locking lip 31 of the locking means 31 and near the end of the locking lip 31 of these locking means. The connecting bridges need to be broken in order to remove the security lip 30 and to allow a user to tilt locking lip 31 of the locking means 31, and can be formed in a (synthetic material, e.g. PE, PP) moulding process of the lid portion 2. In the embodiment shown for instance in fig. 4, it is clear that because a lip is used which is connected using connecting bridges which can be moulded in one go together with the lip and the rest of the lid portion, the security means can be completely integrated in the side wall. In particular, the security lip has a part 35 which extends above the locking lip (at this position, the locking lip has a lower part 36), thus allowing easy removal of the security lip 30. The height of the security lip 30 and of the locking lip 31 should preferably not extend above edge 24 of cam 9.

[0046] According to an aspect of the invention, cams 9 have a substantial height D, e.g. about 5-7 mm. Furthermore, in this embodiment, cams 9 are part of the lid 7 bulging outward with respect to the main plane of the lid (substantially a plane through surface 22 of rim 14). Because of that the cams 9 function as reinforcement ribs adding to the strength of the lid and in this way it is possible to stack a number of container assemblies on top of each other such as is shown for example in fig. 2 in a very stable manner. This effect of providing more rigidity to the lid is increase as a wall of the cam 9 almost extends or goes over into rim 34. This rim 34 of the inside of the lid 7 fits in the inside 23 of inner U-shaped rim 20. The inner U-shaped rim 20 has ribs 21 providing rigidity to the rim 20. The height of this inner side 23 of inner rim 20 is preferably at least the height of cam 9, i.e. about 5-7 mm. Rim 23 of lid 7 extends within the connecting part 8 to such an extend that it leaves enough height of rim 23 free (the already mentioned 5-7 mm) to be able to stably stack lid parts in the way shown in fig. 3.

[0047] The spacing between the outsides or outer walls 25 of the cam portions 9 is indicated in fig. 4 by C.

[0048] According to an aspect of the invention the internal width of the connection portion 8 at least at the lower end thereof is indicated by B, wherein B is slightly larger than C. This allows for stacking of a number of lid parts comprising connection portion 8 and lid 7 on top of each other as is shown in fig. 3 to obtain a stable stack. Such a stable stack is desirable during automated provision of the lid parts on the container parts during assembly thereof.

[0049] In Fig. 1, the spacing between opposite sides of the circumferential rim 5 at the bottom side of container part 3 is indicated by A. Preferably A is about the same as B allowing for stacking of container assemblies using

the combination of the circumferential rim 5 and cam portions 9 of the lid. It will be understood that the dimensions A-C are all taken in the same direction. In different directions A-C will have other values but the same principle applies to provide for stable and robust stacking of both the lid parts and the container assemblies in a later stage. The spacing between the cam and the circumferential rim, the connection portion respectively is preferably about 0,5 mm. Because of the shape of the cam portions there are at least three and preferable four or more points of contact between the related circumferential rim and the cam portions providing a stable stacked assembly. Stacks of ten packages or more can be obtained. The circumferential shape of the rim 5 of the container part 3 and of the cam 9 on the lid 7 are mutually adapted in such a way that the rim 5 closely fits around the cams 9. Furthermore, the diameter B and circumferential shape of rim 23 of the connecting portion is designed in such a way that the circumferential rim 23 of the connecting portion closely fits around cam 9 of lid 7.

[0050] Although in this preferred embodiment the cam portions 9 function both to cooperate with corresponding accommodation in the connection portion 8 and the rim 5 at bottom 4 of the container part, it will be obvious that two sets of cam portions can be provided.

[0051] Lid portion 2 further has a levelling part 27 inside rim 20. This part 27 is provided at the edge of rim 34 at a distance from the lower edge of the inner wall of rim 20 to allow stacking of lid portions 2. This levelling part 27 allows levelling of the spoon.

[0052] Lid 7 further has a dome-shaped part 32 at its centre part for providing additional rigidity of lid 7.

[0053] In the embodiment shows in the drawings, the shape 11 indicating and holding a spoon bulges outward with respect to the plane of lid 7. This may provide additional rigidity to lid 7. It is, however, also conceivable to let for instance the top 24 of cams 9 define the main plane and outside surface of lid 7. In that case, wall 25 still defines stacking means providing an abutment for the rim 5 of the bottom of container portion 3, together with surface 22 of rim 14. In this case, the shape of a spoon may be indicated in another way, and clamping means 29 for a spoon may still be present.

[0054] In another shape of lid 7, shown in fig. 8, connecting part 8 still has a rim 20 with inner side 23 for providing a first element of the first complementary stacking means. In this embodiment of the lid, however, the lid has depressions, in this embodiment a circumferential groove which is dimensioned to retain both rim 20 of the lid part 2 when stacking lid parts, and rim 5 when stacking container assemblies 1. In fact, the groove provides at a groove wall a vertically extending abutment. This vertically extending (with respect to the plane of the lid 7) abutment can also be formed by, when radially following the surface of the lid 7 from the outside 22 to the centre, lowering the surface of the lid with respect to surface 22 of rim 14, thus providing an abutment against forces radially outward. The vertically extending abutment can al-

so be formed by making the surface of the lid higher after surface 22 of rim 14, thus providing an abutment against forces radially inward. In the first embodiment, the outside of rim 5 abuts the abutment of the lid 7, in the second embodiment, the inside of rim 5 abuts the abutment of the lid 7. In both embodiments, the abutment of the lid prevents shifting. It is clear that these abutments do not need to be completely circumferential, but in many designs and practical embodiments, they will be.

[0055] It will also be obvious after the above that further embodiments are within the scope of protection of the appended claims being obvious combinations with prior art techniques and the disclosure of this patent.

Claims

1. Container assembly (1) comprising a container part (3) and a lid part (2), said lid part (2) comprising a connection portion (8) for connection to said container part (3) and a lid (7) being pivotably connected to said connection portion (8), **characterised in that** the side remote from said lid (7) of said connection portion (8) and the side of the lid (7) remote from the connection portion (8) are provided with first complementary stacking means (9, 14, 22, 25, 20, 23, 34).
2. Container assembly according to claim 1, wherein said complementary stacking means comprise a cam (9) and recess or rim (20, 22).
3. Container assembly to one of the preceding claims, wherein said cam (9) is provided on the lid (7) on the side remote from said connection portion (8).
4. Container assembly to one of the preceding claims, wherein the bottom (4) of said container part (3) and the side of said lid (7) being remote from said connection portion are provided with second complementary stacking means (5, 9, 14, 22, 25).
5. Container assembly according to claim 4, wherein said first and second stacking means on said lid are identical.
6. Container assembly according to one of the preceding claims in combination of claim 3, wherein said cam comprises a circumferential cam extending near the outer circumference of said lid.
7. Container assembly according to claim 6, wherein said circumferential cam is provided with interruptions (10).
8. Container assembly according to claim 7, wherein said lid (7) is smooth at a location of said interruptions (10).
9. Container assembly according to one of the preceding claims, wherein said lid (7) is arranged for internally accommodating a spoon, wherein in said lid the at least partial shape (11) of said spoon is provided.
10. Container assembly according to claims 8 and 9, wherein said interruption (10) is provided at the location of said at least partial shape (11).
11. Container assembly according to one of the claims 9 or 10, wherein said lid (7) is rectangular and said at least partial shape (11) extends diagonally.
12. Container assembly according to claim 11, wherein the angles of said rectangle are curved and one side is convex shaped.
13. Container assembly according to any one of the preceding claims, wherein said lid (7) comprising a lip (31) for locking said lid (7) to said connection portion (8), said locking lip (31) being operably connected to said lid (7) and having a cam and said connecting portion having a further cam, both cams positioned for engaging one another to keep said lid locked onto said connecting portion when said locking lip is not operated and to disengage one another when said locking lip is operated, said lid further having a gripping area (28) adjacent said locking lip for arrangement of a finger or thumb of a user when operating said lip.
14. Container assembly according to any one of the preceding claims, wherein the lid (7) is provided with at least one abutment (34) extending in normal direction with respect to a plane of the lid for providing abutment against forces with a component parallel to the plane of the lid, as a part of said first complementary stacking means.
15. Container assembly according to any one of the preceding claims, wherein the side of said connection portion (8) remote from said lid (7) is provided with a circumferential rim (20) as a part of said first complementary stacking means.
16. Container assembly according to any one of the preceding claims, wherein said lid (7) comprising a lip (31) for locking said lid (7) to said connection portion (8), said locking lip (31) being operably connected to said lid and having a cam and said connecting portion having a further cam, both cams positioned for engaging one another to keep said lid onto said connecting portion when said locking lip is not operated and to disengage one another when said locking lip is operated, and said connection portion further comprises a security lip (30) positioned over said locking lip (31) for preventing operation of said lock-

ing lip and providing temper evidence.

5

10

15

20

25

30

35

40

45

50

55

7

Fig 1

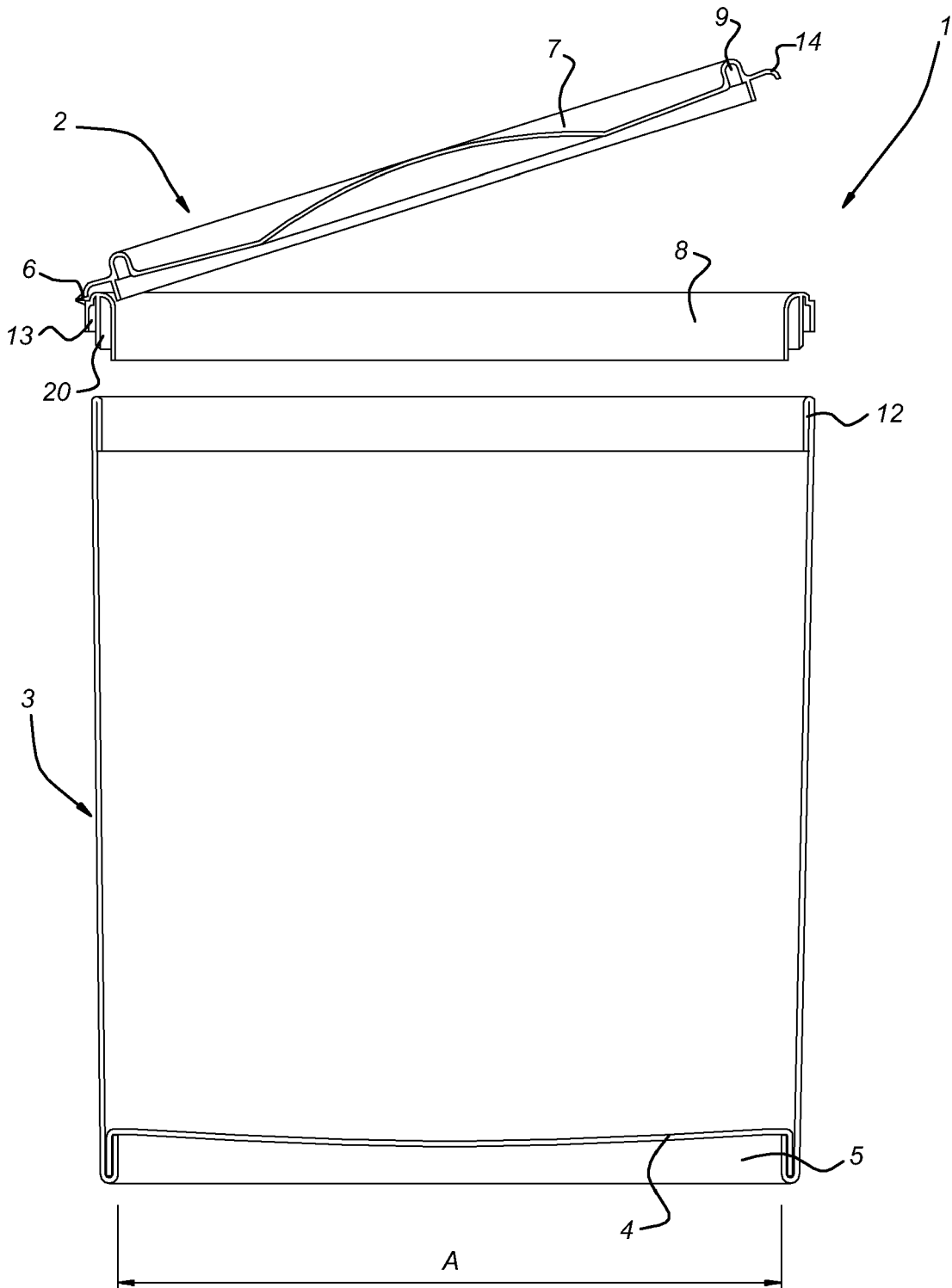

Fig 2

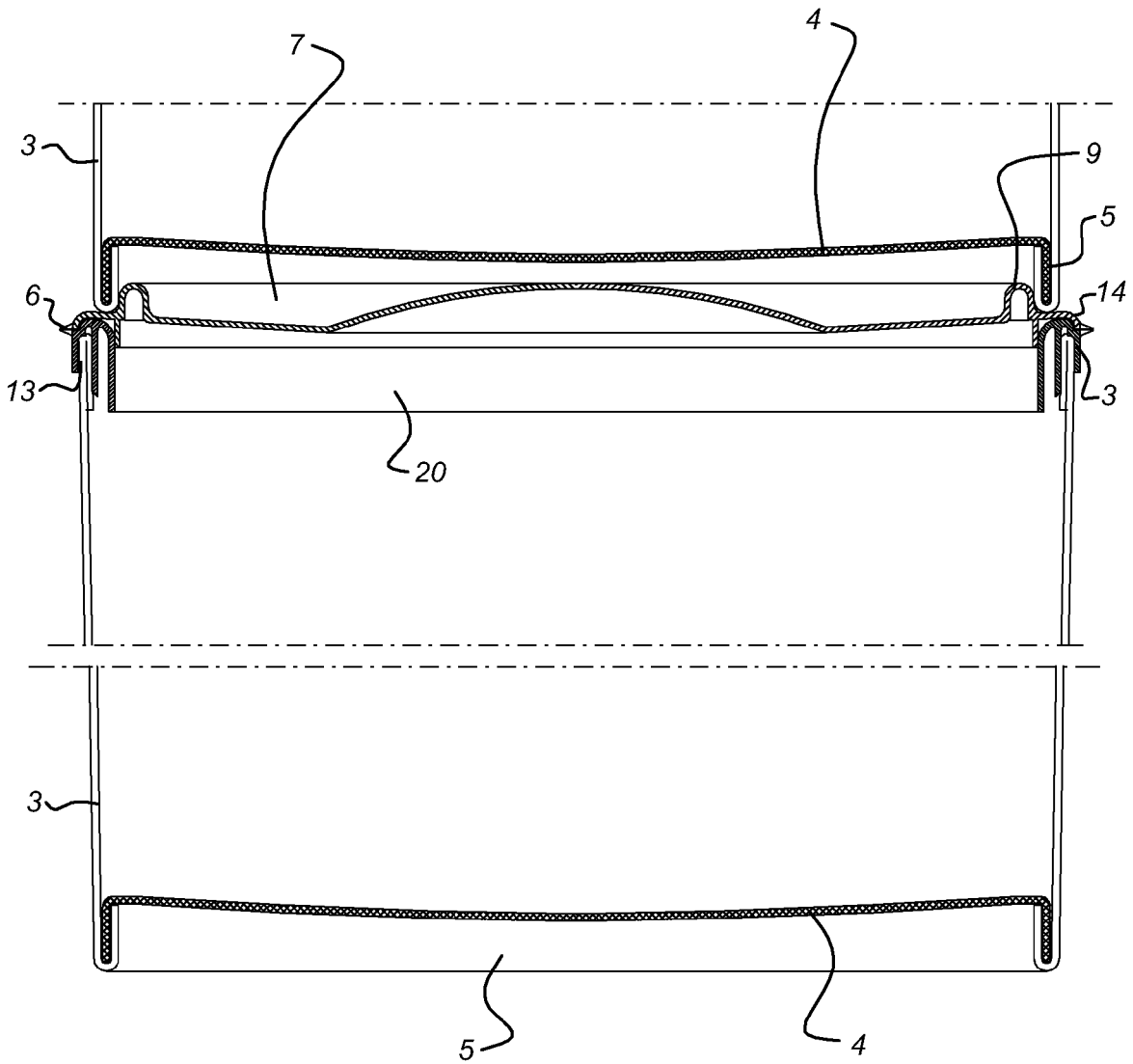

Fig 3

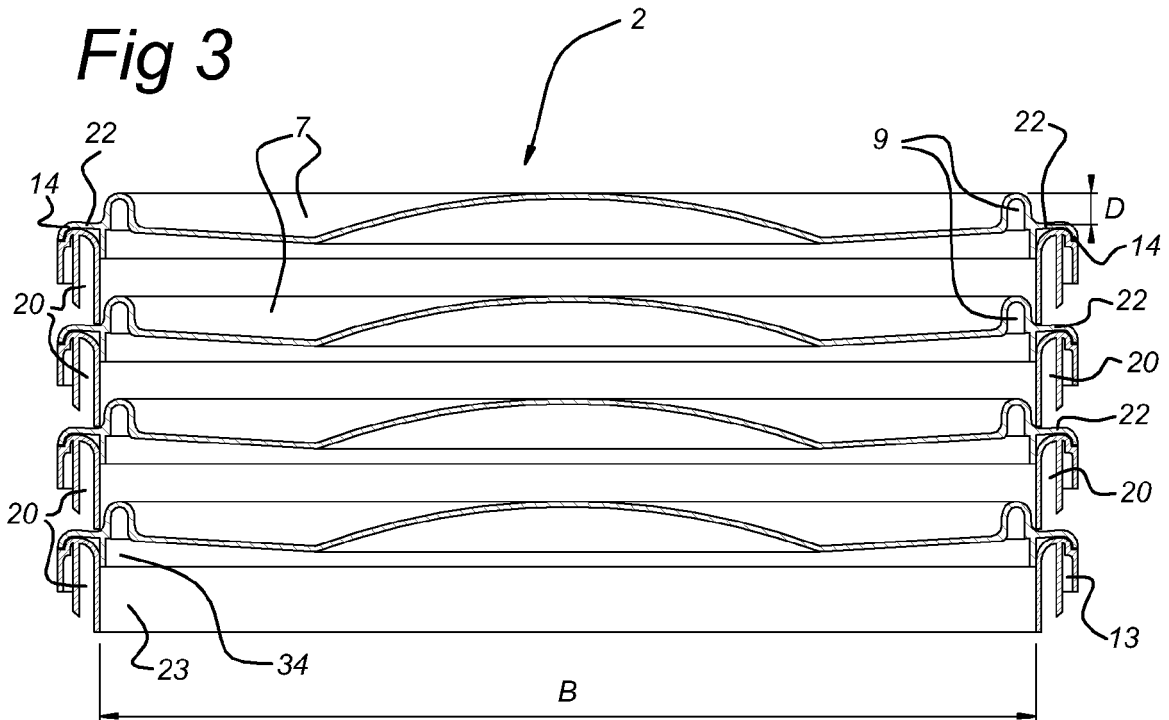

Fig 4

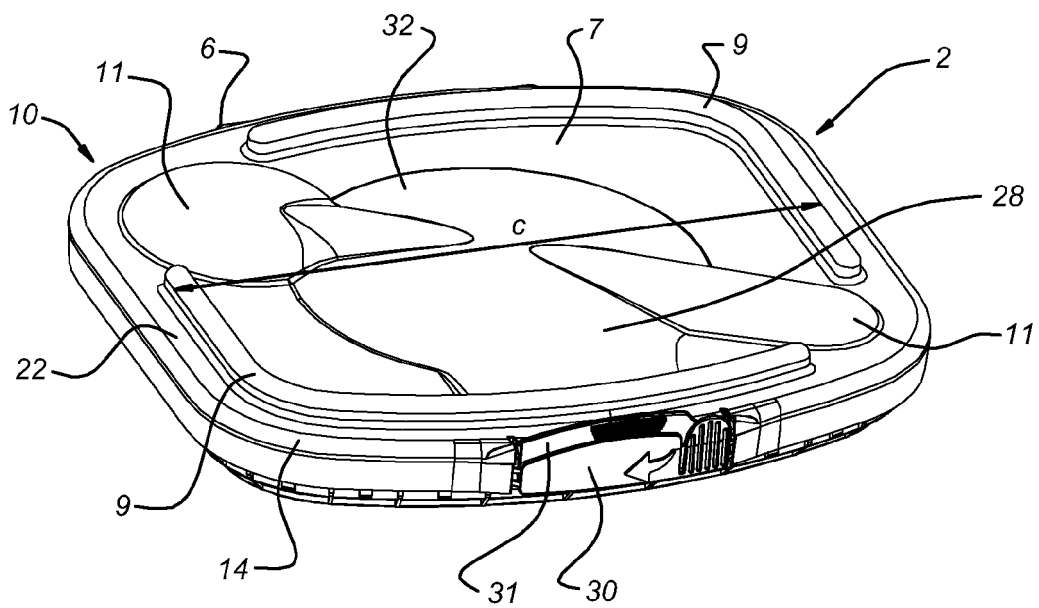

Fig 5

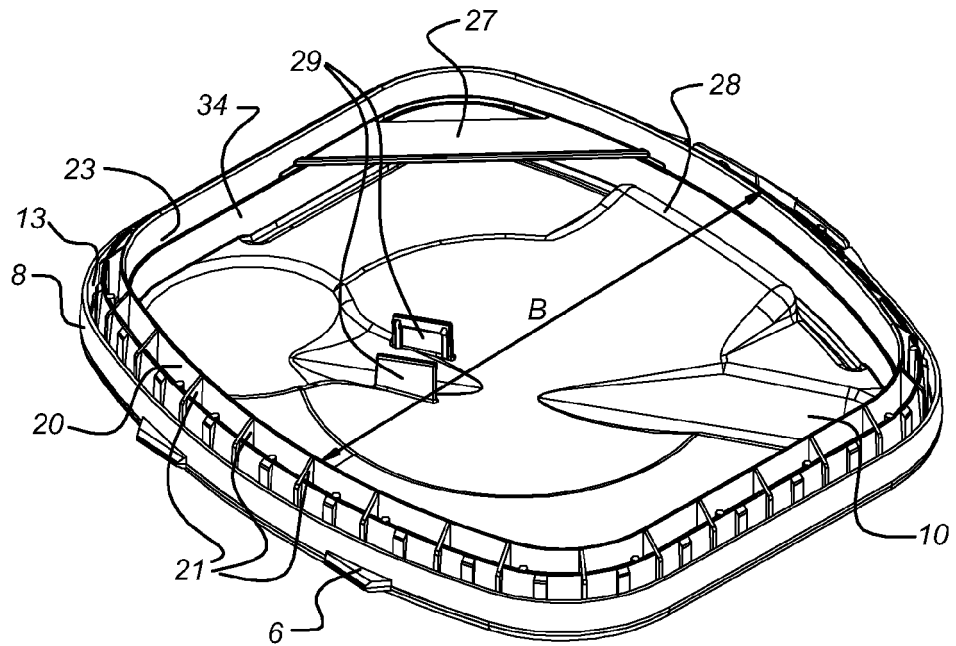

Fig 6

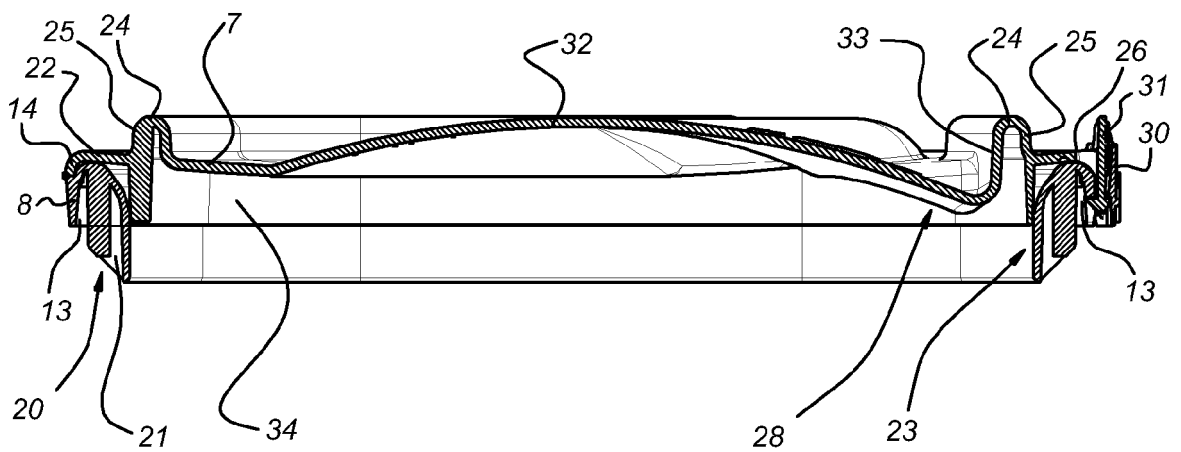

Fig 7

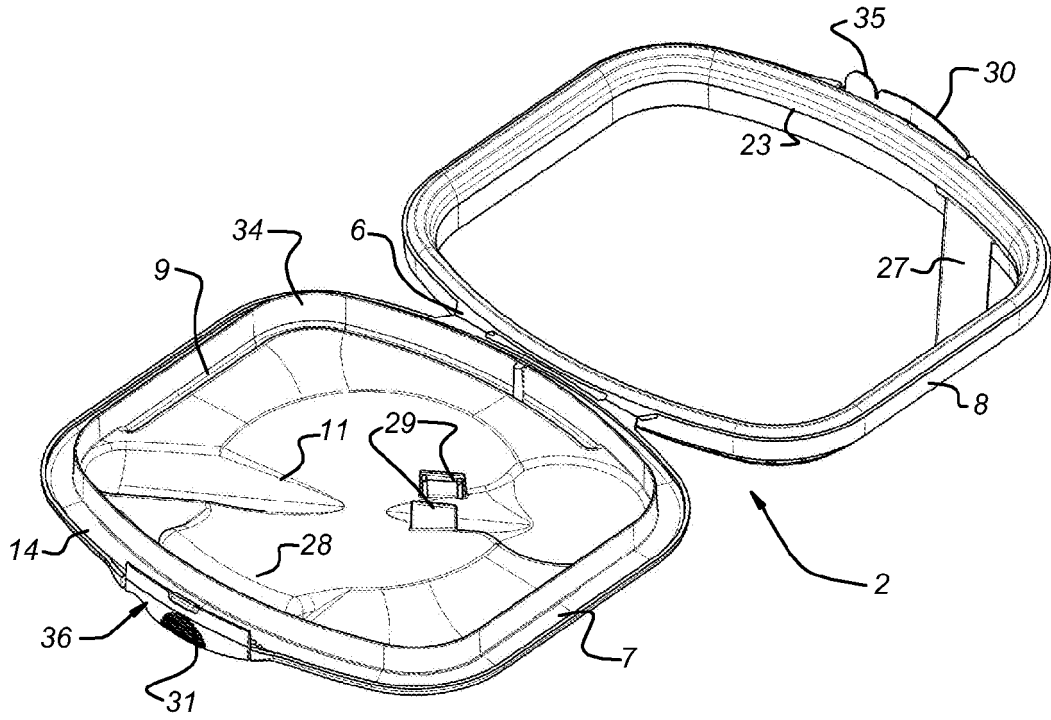
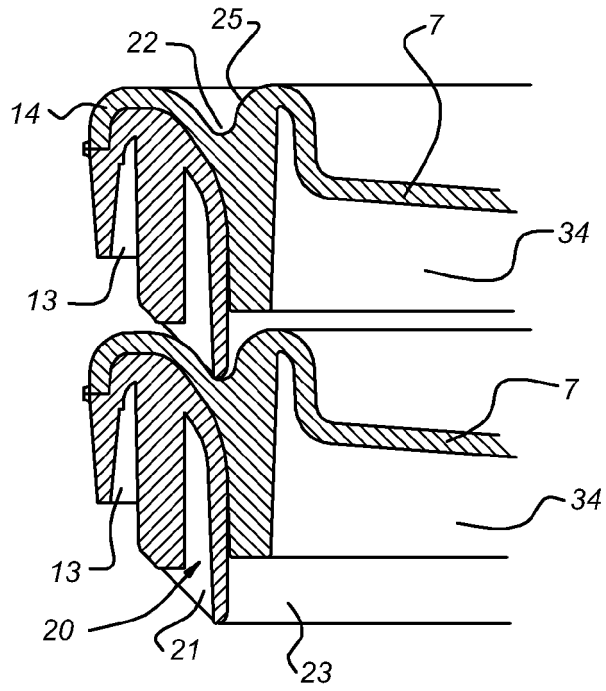

Fig 8





DOCUMENTS CONSIDERED TO BE RELEVANT			
Category	Citation of document with indication, where appropriate, of relevant passages	Relevant to claim	CLASSIFICATION OF THE APPLICATION (IPC)
X	EP 1 512 637 A (HUHTAMAKI FRANCE S A [FR]) 9 March 2005 (2005-03-09)	1,2,9, 14-16	INV. B65D21/02 B65D43/02 B65D51/24
Y	* abstract; figures *	4,11,12	
Y	----- WO 2005/075314 A (NUTRICIA NV [NL]; CRAWFORD KAREN RITA [GB]; LUTTIK NICOLAAS [NL]) 18 August 2005 (2005-08-18) * page 8, line 25 - line 29; figures *	4,11,12	
A	----- US 5 219 087 A (CHRISTENSSON LARS [SE]) 15 June 1993 (1993-06-15)	1	
A	----- US 2006/068063 A1 (ZERFAS PAUL A [US] ET AL) 30 March 2006 (2006-03-30)		
A	----- EP 0 072 294 A1 (MOULAGE AUTOMATIQUE SA LE [FR]) 16 February 1983 (1983-02-16) -----		
The present search report has been drawn up for all claims			TECHNICAL FIELDS SEARCHED (IPC)
			B65D
Place of search		Date of completion of the search	Examiner
The Hague		25 July 2007	SERRANO GALARRAGA, J
CATEGORY OF CITED DOCUMENTS			
X : particularly relevant if taken alone Y : particularly relevant if combined with another document of the same category A : technological background O : non-written disclosure P : intermediate document		T : theory or principle underlying the invention E : earlier patent document, but published on, or after the filing date D : document cited in the application L : document cited for other reasons & : member of the same patent family, corresponding document	

3
EPO FORM 1503 03.02 (F04C01)

ANNEX TO THE EUROPEAN SEARCH REPORT
ON EUROPEAN PATENT APPLICATION NO.

EP 07 10 9447

This annex lists the patent family members relating to the patent documents cited in the above-mentioned European search report.
The members are as contained in the European Patent Office EDP file on
The European Patent Office is in no way liable for these particulars which are merely given for the purpose of information.

25-07-2007

Patent document cited in search report		Publication date	Patent family member(s)	Publication date
EP 1512637	A	09-03-2005	FR 2859182 A1	04-03-2005
WO 2005075314	A	18-08-2005	AU 2005210583 A1	18-08-2005
			BR PI0507171 A	26-06-2007
			CA 2551407 A1	18-08-2005
			CN 1914096 A	14-02-2007
US 5219087	A	15-06-1993	AU 5825290 A	07-01-1991
			DE 69005109 D1	20-01-1994
			DE 69005109 T2	28-04-1994
			EP 0474756 A1	18-03-1992
			JP 2811605 B2	15-10-1998
			JP 4505439 T	24-09-1992
			SE 463762 B	21-01-1991
			SE 8901969 A	01-12-1990
			WO 9014999 A1	13-12-1990
US 2006068063	A1	30-03-2006	CA 2580950 A1	06-04-2006
			EP 1809544 A1	25-07-2007
			WO 2006036792 A1	06-04-2006
EP 0072294	A1	16-02-1983	DE 3267168 D1	05-12-1985
			DE 72294 T1	26-05-1983
			FR 2511346 A1	18-02-1983
			US 4454958 A	19-06-1984

REFERENCES CITED IN THE DESCRIPTION

This list of references cited by the applicant is for the reader's convenience only. It does not form part of the European patent document. Even though great care has been taken in compiling the references, errors or omissions cannot be excluded and the EPO disclaims all liability in this regard.

Patent documents cited in the description

- NL 2005000089 W [0002]
- FR 2747107 [0004]
- US 5705212 A [0004]
- JP 2001019006 B [0004]
- JP 2000344243 B [0004]
- FR 1338551 [0004]
- US 6604645 B [0004]
- DE 19815364 [0004]
- CH 381606 [0004]
- CH 671749 [0004]
- EP 1157936 A [0004]
- GB 2250271 A [0004]
- US 5219087 A [0004]