



(12) **EUROPEAN PATENT APPLICATION**

(43) Date of publication:
12.12.2007 Bulletin 2007/50

(51) Int Cl.:
F02M 61/16^(2006.01)

(21) Application number: **06011630.8**

(22) Date of filing: **06.06.2006**

(84) Designated Contracting States:
AT BE BG CH CY CZ DE DK EE ES FI FR GB GR HU IE IS IT LI LT LU LV MC NL PL PT RO SE SI SK TR
 Designated Extension States:
AL BA HR MK YU

(71) Applicant: **SIEMENS AKTIENGESELLSCHAFT**
80333 München (DE)

(72) Inventors:
 • **Biasci, Enio**
56010 Campo (Pisa) (IT)
 • **Zimmitti, Federico**
56121 Pisa (IT)

(54) **Method for adjusting an injection valve**

(57) Method for adjusting an injection valve (10), the injection valve (10) comprising a housing (12) including a central longitudinal axis (A), the housing (12) comprising a cavity (24) with a fluid outlet portion (28), a valve needle (22) axially movable in the cavity (24), the valve needle (10) preventing a fluid flow through the fluid outlet portion (44) in a closing position and releasing the fluid flow through the fluid outlet portion (44) in further positions, an actuator unit (16) being coupled to the valve needle (22) and enabling the axial movement of the valve

needle (22) relative to the valve body (20) upon actuation of the actuator unit (16), and an adjusting arrangement (14). The adjusting arrangement (14) comprises a spring retaining element (42) being coupable to the housing (12), a thermal compensation unit (40) being coupable to the spring retaining element (42), and an adjusting spring (44) arranged between the thermal compensation unit (40) and the spring retaining element (42) and being enabled to exert an axial preload force on the actuator unit (16).

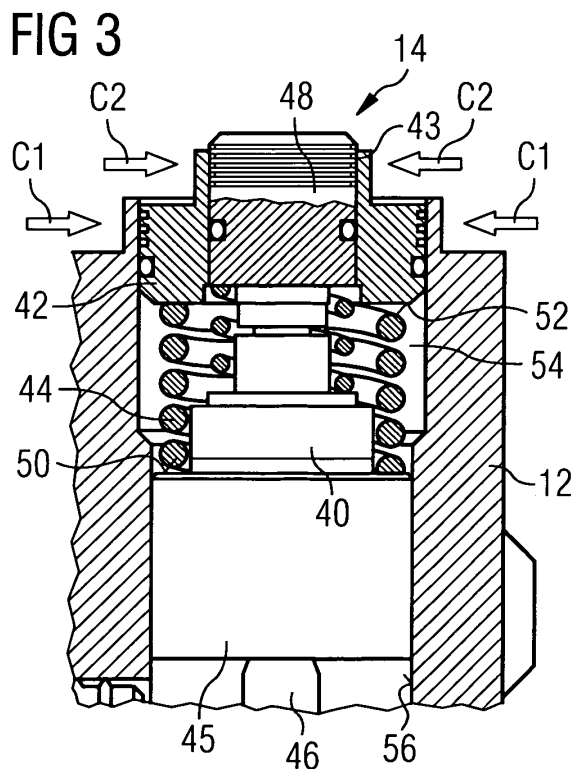

Description

[0001] The invention relates to a method for adjusting an injection valve.

[0002] Injection valves are in wide spread use, in particular for internal combustion engines where they may be arranged in order to dose the fluid into an intake manifold of the internal combustion engine or directly into the combustion chamber of a cylinder of the internal combustion engine.

[0003] Injection valves for an internal combustion engine comprise actuator units. In order to inject fuel, the actuator unit is energized so that a fluid flow through the fluid outlet portion of the injection valve is enabled.

[0004] In order to enhance the combustion process in view of the creation of unwanted emissions, the respective injection valve may be suited to dose fluids under very high pressures. The pressures may be in case of a gasoline engine, for example, in the range of up to 200 bar and in the case of a diesel engine in the range of up to 2,000 bar. The injection of fluids under such high pressures has to be carried out very precisely.

[0005] Injection valves are calibrated at the end of the manufacturing process to obtain a defined and precise mass flow of the fluid through a fluid outlet portion of the injection valve.

[0006] The object of the invention is to provide a method for adjusting an injection valve which is to be carried out simply and which facilitates a reliable and precise function of the injection valve.

[0007] This object is achieved by the features of the independent claim. Advantageous embodiments of the invention are given in the sub-claims.

[0008] The invention is distinguished by a method for adjusting an injection valve, the injection valve comprising a housing including a central longitudinal axis, the housing comprising a cavity with a fluid outlet portion, a valve needle axially moveable in the cavity, the valve needle preventing a fluid flow through the fluid outlet portion in a closing position and releasing the fluid flow for the fluid outlet portion in further positions, an actuator unit being coupled to the valve needle and enabling the axial movement of the valve needle relative to the valve body upon actuation of the actuator unit, and an adjusting arrangement. The adjusting arrangement comprises a spring retaining element being coupable to the housing, a thermal compensation unit being coupable to the spring retaining element and an adjusting spring arranged between the thermal compensation unit and the spring retaining element and being enabled to exert an axial preload force on the actuator unit. The method comprises the following steps: providing the injection valve and coupling of the injection valve with a fluid supply for the adjustment purpose, actuating of the actuator unit to release the fluid flow through the fluid outlet portion, moving the spring retaining element relative to the housing until a predetermined fluid flow through the fluid outlet portion is obtained, carrying out a fixed coupling of the spring

retaining element with the housing, and carrying out a fixed coupling of the thermal compensation unit with the spring retaining element.

[0009] The fixed coupling of the thermal compensation unit with the spring retaining element and the fixed coupling of the spring retaining element with the housing is realized at the end of the adjusting process.

[0010] This has the advantage that it is possible to obtain a precise fixing position of the thermal compensation unit at the end of the adjusting process which allows a secure operation of the thermal compensation unit due to changes of the temperature in the ambience of the injection valve.

[0011] In an advantageous embodiment the coupling of the spring retaining element with the housing is carried out by crimping. In a further advantageous embodiment of the invention the coupling of the thermal compensation unit with the spring retaining element is carried out by crimping. Crimping allows a fast, secure and precise fixed coupling of the participating elements, in particular the spring retaining element and the housing respectively the thermal compensation unit and the spring retaining element.

[0012] Exemplary embodiments of the invention are explained in the following with the aid of schematic drawings. These are as follows:

Figure 1, an injection valve in a longitudinal section view,

Figure 2, an adjusting arrangement for the injection valve according to figure 1 in a longitudinal section view, and

Figure 3, an enlarged view of the adjusting arrangement for the injection valve according to figure 2 in a longitudinal section view.

[0013] Elements of the same design and function that appear in different illustrations are identified by the same reference characters.

[0014] An injection valve 10 (figure 1) that is used as fuel injection valve for an internal combustion engine, comprises a housing 12, an adjusting arrangement 14 and an actuator unit 16.

[0015] The housing 12 has a tubular shape. The actuator unit 16 is inserted into the housing 12 and comprises a piezo actuator, which changes its axial length depending on a control signal applied to it. The actuator unit 16 may, however, also comprise another type of actuator, which is known to a person skilled in the art for that purpose. Such an actuator may be, for example, a solenoid.

[0016] The injection valve 10 comprises a valve body 20 with a central longitudinal axis A and a cavity 24 which is axially led through the valve body 20. On one of the free ends of the cavity 24, a fluid outlet portion 28 is formed, which is closed or open depending on the axial position of a valve needle 22. The injection valve 10 fur-

ther has a fluid inlet portion 26 which is arranged in the housing 12 and which is hydraulically coupled to the cavity 24 and a not shown fuel connector. The fuel connector is designed to be connected to high pressure fuel chamber of an internal combustion engine, the fuel is stored under high pressure, for example, under the pressure of about 200 bar.

[0017] The valve body 20 has a valve body spring rest 32 and the valve needle 22 comprises a valve needle spring rest 34, both spring rests 32, 34 supporting a main spring 30 arranged between the valve body 20 and the valve needle 22.

[0018] The injection valve 10 is of an outward opening type. In an alternative embodiment the injection valve 10 may be of an inward opening type. Between the valve needle 22 and the valve body 20 a bellow 36 is arranged which is sealingly coupling the valve body 20 with the valve needle 22. By this a fluid flow between the cavity 24 and a chamber 38 is prevented. Furthermore, the bellow 36 is formed and arranged in a way that the valve needle 22 is actuatable by the actuator unit 16.

[0019] Figures 2 and 3 show the adjusting arrangement 14. The housing 12 has a recess 54 with an inner wall 56. In the recess 54 of the housing 12 a thermal compensation unit 40, a spring retaining element 42 and an adjusting spring 44 are arranged. The thermal compensation unit 40 has a first section 45 which is coupled to a piston 46 of the actuator unit 16. The spring retaining element 42 has a cylindrical spring retaining element cavity 43 in which a cylindrical second section 48 of the thermal compensation unit 40 is arranged.

[0020] The thermal compensation unit 40 has a thermal compensation unit spring rest 50 and the spring retaining element 42 comprises a spring retaining element spring rest 52, both spring rests 50, 52 supporting the adjusting spring 44 arranged between the thermal compensation unit 40 and the spring retaining element 42.

[0021] In the following, the function of the injection valve 10 will be described:

[0022] The fuel is led from the fluid inlet portion 26 and the housing 12 towards the valve body 20 and then towards the fluid outlet portion 28. The fluid flow from the fluid outlet portion 28 to the chamber 38 with the actuator unit 16 is prevented by the bellow 36.

[0023] The valve needle 22 prevents a fluid flow through the fluid outlet portion 28 in the valve body 20 in a closing position of the valve needle 22. Outside of the closing position of the valve needle 22 the valve needle 22 enables the fluid flow through the fluid outlet portion 28.

[0024] In the case that the actuator unit 16 has a piezo electric actuator, the piezoelectric actuator may change its axial length if it gets energized in an expansion duration of some microseconds. By changing its length the actuator unit 16 may effect a force on the valve needle 22. Due to the elasticity of the bellow 36 the valve needle 22 is able to move in axial direction out of the closing position. Outside of the closing position of the valve nee-

dle 22 there is a gap between the valve body 20 and the valve needle 22 at an axial end of the injection valve 10 facing away from the actuator unit 16. The gap forms a valve nozzle 29.

[0025] The main spring 30 can force the valve needle 22 via the valve needle spring rest 34 towards the actuator unit 16. In the case that the actuator unit 16 is de-energized the actuator unit 16 shortens its length. The main spring 30 can force the valve needle 22 to move in axial direction in its closing position. It is depending on the force balance between the force on the valve needle 22 caused by the actuator unit 16 and the force on the valve needle 22 caused by the main spring 30 whether the valve needle 22 is in its closing position or not.

[0026] In the following, the method for adjusting the injection valve 10 will be described in detail:

[0027] The injection valve 10 is provided and coupled with the fluid supply in particular a high pressure fuel chamber. The actuator unit 16 is actuated and the gap between the valve body 20 and the valve needle 22 at the axial end of the injection valve 10 facing away from the actuator unit 16 allows to release the fluid flow through the fluid outlet portion 28.

[0028] The spring retaining element 42 is moved in axial direction relative to the housing until a predetermined fluid flow through the fluid outlet portion 28 is obtained. The movement of the spring retaining element 42 relative to the housing 12 in direction to the actuator unit 16 results in a compression of the adjusting spring 44 thereby exerting an axial preload force on the actuator unit 16 via the first section 45 of the thermal compensation unit 40. If the predetermined fluid flow through the fluid outlet portion 28 is obtained the spring retaining element 42 and the housing 12 are crimped together in first crimping directions C1 to obtain a fixed coupling between the spring retaining element 42 and the housing 12. In a further step the thermal compensation unit 40 and the spring retaining element 42 are crimped together in second crimping directions C2 to obtain a fixed coupling between the thermal compensation unit 40 and the spring retaining element 42.

[0029] By this, the housing 12, the spring retaining element 42 and the thermal compensation unit 40 are fixedly coupled just in the end of the adjusting process. This has the advantage that the position of the thermal compensation unit 40 is defined very precisely as the crimping process allows a very exact definition of the positions of the parts which are crimped together.

[0030] After carrying out the method for adjusting the injection valve 10 the fluid supply can remain to be coupled with the injection valve 10. However, preferably the fluid supply is disconnected from the injection valve after the method for adjusting the injection valve 10 has been carried out.

55

Claims

1. Method for adjusting an injection valve (10), the injection valve (10) comprising
- a housing (12) including a central longitudinal axis (A), the housing (12) comprising a cavity (24) with a fluid outlet portion (28),
 - a valve needle (22) axially movable in the cavity (24), the valve needle (10) preventing a fluid flow through the fluid outlet portion (44) in a closing position and releasing the fluid flow through the fluid outlet portion (44) in further positions,
 - an actuator unit (16) being coupled to the valve needle (22) and enabling the axial movement of the valve needle (22) relative to the valve body (20) upon actuation of the actuator unit (16), and
 - an adjusting arrangement (14) comprising
 - a spring retaining element (42) being coupable to the housing (12),
 - a thermal compensation unit (40) being coupable to the spring retaining element (42), and
 - an adjusting spring (44) arranged between the thermal compensation unit (40) and the spring retaining element (42) and being enabled to exert an axial preload force on the actuator unit (16),
- the method comprising the following steps:
- providing the injection valve (10) and coupling of the injection valve (10) with a fluid supply for the adjustment purpose,
 - actuating of the actuator unit (16) to release the fluid flow through the fluid outlet portion (28),
 - moving the spring retaining element (42) relative to the housing (12) until a predetermined fluid flow through the fluid outlet portion (28) is obtained,
 - carrying out a fixed coupling of the spring retaining element (42) with the housing (12), and carrying out a fixed coupling of the thermal compensation unit (40) with the spring retaining element (42).
2. Method in accordance with claim 1 with the coupling of the spring retaining element (42) with the housing (12) is carried out by crimping.
3. Method in accordance with claim 1 with the coupling of the thermal compensation unit (40) with the spring retaining element (42) is carried out by crimping.

5

10

15

20

25

30

35

40

45

50

55

FIG 1

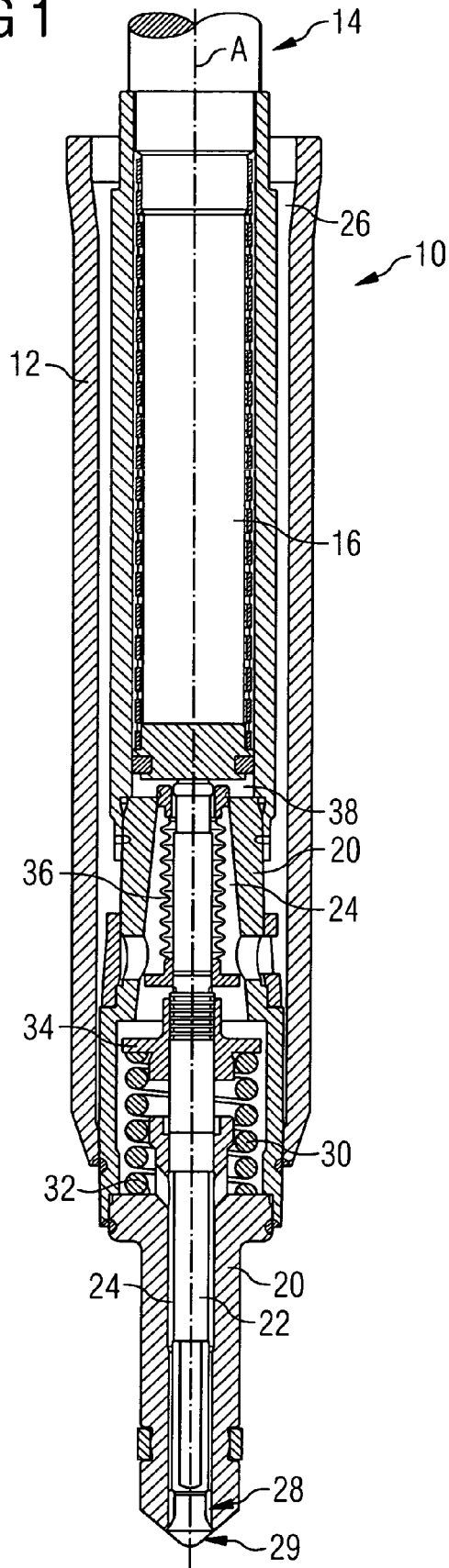

FIG 2

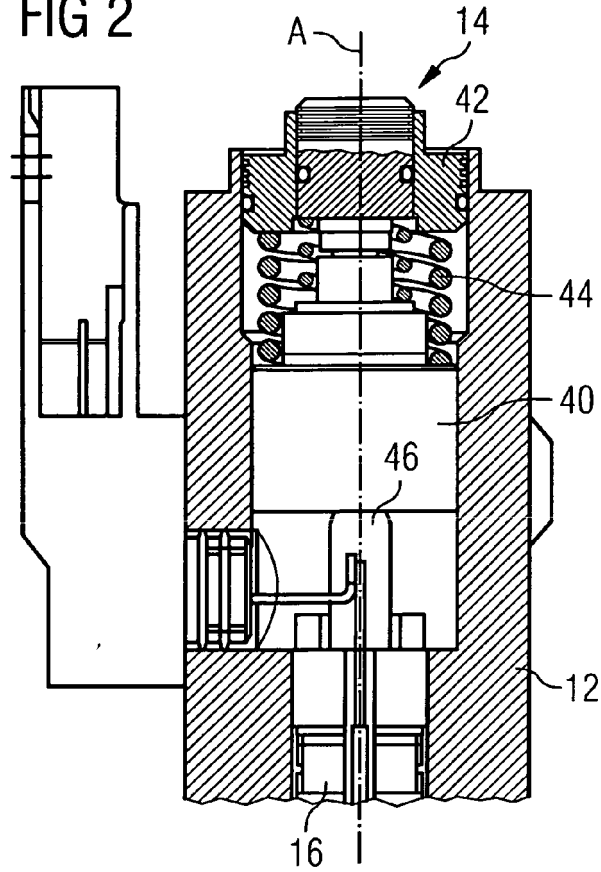
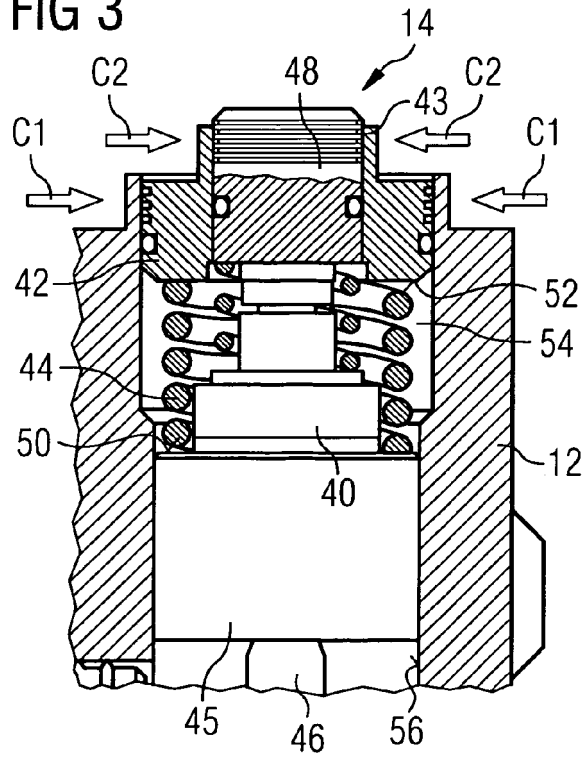

FIG 3





DOCUMENTS CONSIDERED TO BE RELEVANT			
Category	Citation of document with indication, where appropriate, of relevant passages	Relevant to claim	CLASSIFICATION OF THE APPLICATION (IPC)
A	EP 1 593 841 A (BOSCH GMBH ROBERT [DE]) 9 November 2005 (2005-11-09) * paragraphs [0040] - [0045]; figures *	1-3	INV. F02M61/16
A	US 2005/056706 A1 (CROFTS JOHN D [US]) 17 March 2005 (2005-03-17) * abstract; figures *	1-3	
A	EP 1 450 036 A (SIEMENS VDO AUTOMOTIVE S P A [IT]) 25 August 2004 (2004-08-25) * the whole document *	1-3	
A	EP 1 445 477 A1 (SIEMENS VDO AUTOMOTIVE S P A [IT]) 11 August 2004 (2004-08-11) * the whole document *	1-3	
			TECHNICAL FIELDS SEARCHED (IPC)
			F02M
The present search report has been drawn up for all claims			
Place of search		Date of completion of the search	Examiner
The Hague		1 November 2006	Blanc, Sébastien
CATEGORY OF CITED DOCUMENTS			
X : particularly relevant if taken alone Y : particularly relevant if combined with another document of the same category A : technological background O : non-written disclosure P : intermediate document		T : theory or principle underlying the invention E : earlier patent document, but published on, or after the filing date D : document cited in the application L : document cited for other reasons & : member of the same patent family, corresponding document	

2

EPO FORM 1503 03.82 (F04C01)

**ANNEX TO THE EUROPEAN SEARCH REPORT
ON EUROPEAN PATENT APPLICATION NO.**

EP 06 01 1630

This annex lists the patent family members relating to the patent documents cited in the above-mentioned European search report. The members are as contained in the European Patent Office EDP file on
The European Patent Office is in no way liable for these particulars which are merely given for the purpose of information.

01-11-2006

Patent document cited in search report	Publication date	Patent family member(s)	Publication date
EP 1593841 A	09-11-2005	DE 102004021921 A1	01-12-2005
US 2005056706 A1	17-03-2005	NONE	
EP 1450036 A	25-08-2004	NONE	
EP 1445477 A1	11-08-2004	DE 60304442 T2 JP 2004225687 A	24-08-2006 12-08-2004

EPO FORM P0459

For more details about this annex : see Official Journal of the European Patent Office, No. 12/82