

(19)



(11)

EP 1 867 943 A1

(12)

EUROPEAN PATENT APPLICATION

(43) Date of publication:
19.12.2007 Bulletin 2007/51

(51) Int Cl.:
F28D 1/04 (2006.01) F28F 9/00 (2006.01)

(21) Application number: **06425395.8**

(22) Date of filing: **12.06.2006**

(84) Designated Contracting States:
AT BE BG CH CY CZ DE DK EE ES FI FR GB GR HU IE IS IT LI LT LU LV MC NL PL PT RO SE SI SK TR
Designated Extension States:
AL BA HR MK YU

(71) Applicant: **DENSO THERMAL SYSTEMS S.p.A.**
10046 Poirino (Torino) (IT)

(72) Inventor: **Masciandara, Eustachio,**
Denso Thermal Systems Spa
10046 Poirino (Torino) (IT)

(74) Representative: **Marchitelli, Mauro**
c/o Buzzi, Notaro & Antonielli d'Oulx Srl
Via Maria Vittoria 18
10123 Torino (IT)

(54) **Heat exchange module for vehicles**

(57) Heat exchange module (10) for vehicles, comprising:

- a radiator (14) having two vertical and parallel collecting tanks (22),
- a condenser (16) having two parallel vertical distributor and facing a front face of the radiator (14),
- an intercooler (18) positioned underneath the condenser (16) and the radiator (14), and
- a fan assembly (20) facing a rear face of the radiator (14) and including a support structure (34) bearing at least one electric fan (36),

The radiator (14) has two upper vertical pins (26)

that engage respective holes (40) provided on the support structure (34) of the fan assembly (20). A pair of first brackets (42) are fastened by means of horizontal screws (44) to the lower part of the support structure (34) of the fan assembly. The radiator (14) and the intercooler (18) are fastened by means of screws (46) to the first brackets (42). A pair of second brackets (52) are fastened to the intercooler (18). The second brackets (52) are provided with respective vertical pins (56) which engage respective seats provided at the lower ends of the distributors (28) of the condenser (16). The condenser (16) is fastened to the radiator (14) by means of horizontal screws (60).

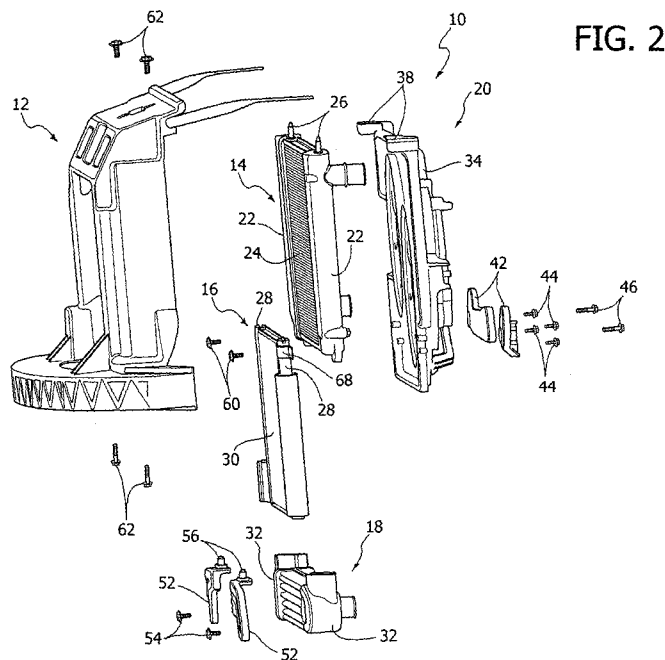

FIG. 2

EP 1 867 943 A1

Description

[0001] The present invention relates to a heat exchange module for vehicles, to be mounted in the front part of a vehicle and comprising a radiator, an air conditioner facing a front face of the radiator, an intercooler positioned underneath the condenser and the radiator, and a fan assembly facing a rear face of the radiator and including a support structure bearing at least one electric fan.

[0002] When it is necessary to replace or remove the condenser and the radiator of a vehicle, it is necessary to drain the circuit of the engine cooling fluid in the case of the radiator and the circuit of the cooling fluid in the case of the condenser

[0003] In heat exchange modules for vehicles, there is the need to ensure that the condenser and the radiator can be disassembled independently from each other, to avoid having to empty the fluid circuit of both components when only one of the two has to be removed.

[0004] The object of the present invention is to provide a heat exchange module that enables to meet the aforesaid need in simple fashion and with a reduced number of fastening components.

[0005] According to the present invention, said object is achieved by a heat exchange module having the characteristics set out in the claims.

[0006] The present invention shall now be described in detail with reference to the accompanying drawings, provided purely by way of non limiting example, in which:

- Figure 1 is a partially exploded view of a heat exchange module according to the present invention facing a support comprised in the structure of the vehicle,
- Figure 2 is an exploded perspective view of the heat exchange module of Figure 1,
- Figure 3 is a perspective view of the fan assembly of the heat exchange module according to the invention,
- Figure 4 is a perspective view of the heat exchange module seen from the side of the fan assembly,
- Figure 5 is an enlarged scale perspective view of the detail indicated by the arrow V in Figure 4,
- Figure 6 is a perspective view of the detail of Figure 5 observed in the direction indicated in the arrow VI in Figure 5,
- Figure 7 is a front elevation view of the heat exchange module of the invention according to the arrow VII of Figure 1,
- Figures 8 and 9 are enlarged scale perspective views of the details indicated by the arrows VIII and IX in Figure 7,
- Figure 10 is a perspective view showing a detail of the condenser disassembly step,
- Figure 11 is a perspective view showing a step in the disassembly of the radiator,
- Figure 12 is a perspective view in the direction indi-

cated by the arrow XII in Figure 11,

- Figure 13 is a sectioned perspective view according to the line XIII-XIII of Figure 11.

5 **[0007]** With reference to Figures 1 and 2, the number 10 designates a heat exchange module for vehicles, to be fastened to a support 12 comprised in the front structure of a vehicle.

10 **[0008]** With reference in particular to Figure 2, the heat exchange module 10 comprises a radiator 14 for cooling the engine, a condenser 16 comprised in the air conditioning system of the vehicle, an intercooler 18 for cooling the flow of air aspirated by the engine and a fan assembly 20.

15 **[0009]** The radiator 14 has two collecting tanks which extend at opposite parts of a heat exchange core 24. The collecting tanks 22, preferably constituted of plastic material, are provided at their upper ends with two vertical pins 26.

20 **[0010]** The condenser 16 faces a front face of the radiator 14 and comprises two vertical distributors 28 positioned at opposite parts of a heat exchange core 30.

25 **[0011]** The intercooler 18 is situated underneath the condenser 16 and the radiator 14 and comprises two lateral manifolds 32.

30 **[0012]** With reference to Figures 2 and 3, the fan assembly 20 comprises a support structure 34 made of plastic material having substantially the shape of a rectangular frame. The support structure 20 has its front face facing a rear face of the radiator 14. The support structure 34 bears one or more electric fans 36. In the illustrated example, two electric fans 36 are provided, able to create a flow of air orthogonal to the heat exchange cores 24, 30 of the radiator 14 and of the condenser 16. The support structure 34 of the fan assembly 20 comprises two integral arm 38 positioned at its upper vertices. The integral arms 38 of the support structure 34 are provided with respective holes 40 with vertical axis able to receive the pins 26 projecting from the upper part of the collecting tanks 22 of the radiator 14.

35 **[0013]** The way in which the components of the heat exchange module 10 are assembled and fastened to each other is described below.

40 **[0014]** The radiator 14 is mounted on the support structure 34 of the fan assembly 20 inserting the vertical pins 26 of the radiator 14 into the holes 40 of the integral arms 38 of the support structure 34 (Figures 2 and 3). A pair of first fastening brackets 42 is fastened to the lower part of the support structure 34. The first brackets 42 are applied on the rear side of the support structure 34 and project towards the exterior of the structure 34 in transverse direction.

45 **[0015]** With reference to Figures 2, 4, 5 and 6, the intercooler 18 is positioned on the support structure 34 of the fan assembly 20 underneath the radiator 14. The radiator 14 and the intercooler 18 are both fastened to the first brackets 42 by means of two horizontal screws 46. As shown in particular in the detail of Figure 6, each screw

46 engages a first bracket 42, an ear 48 projecting from the manifold 32 of the intercooler 18, and an ear 50 projecting from the collecting tank 22 of the radiator 14. Therefore, by means of the first brackets 42 and of the screws 44, 46, the radiator 14 and the intercooler 18 are completely fastened to the support structure 34 of the fan assembly 20.

[0016] At this point, the condenser 16 is positioned and fastened with respect to the other components of the module.

[0017] With reference in particular to Figures 2 and 9, a pair of second fastening brackets 52 is fastened to the manifolds 32 of the intercooler 18. Each second bracket 52 is fastened to a respective manifold 32 of the intercooler by means of a horizontal screw 54. As shown in Figures 2 and 6, each second bracket 52 is provided with a vertical pin 56 which is inserted into a seat formed at the lower end of a respective distributor 28 of the condenser 16. Preferably, between the pins 56 and the seats of the distributors 28 is interposed an element of damping material.

[0018] With reference to Figures 7 and 8, the condenser 16 is provided with two metal flanges 58 welded to the upper ends of the distributors 28. The flanges 58 project in transverse direction outwardly relative to the distributors 28. Each flange 58 is fastened by means of a horizontal screw 60 to the corresponding collecting tank 22 of the radiator 14. The screws 60 complete the fastening of the condenser 16 to the heat exchange module 10.

[0019] As shown in Figure 1, the complete heat exchange module is fastened to the support 12 by means of vertical screws 62 that engage holes provided in the support structure 34 of the fan assembly 20.

[0020] Starting from the condition in which the module 10 is fastened to the support 12, it is possible to remove the radiator 14 or the condenser 16 independently from each other.

[0021] To remove only the condenser 16, the following procedure is carried out.

[0022] As shown in Figure 10, to each of the vertical pins 26 of the radiator 14 is applied a cotter pin 64. Then, acting from the front part of the support 12, the screws 60 that fasten the flanges 58 of the condenser 16 to the collecting tanks 22 of the radiator 14 are removed. Then, acting from the rear part of the heat exchange module, the screws that fasten the intercooler 18 and the radiator 14 to the first brackets 42 are removed. Then, the intercooler 18 is removed and the condenser 16 is extracted with a downwards movement. After the removal of the screws 46 that fasten the radiator 14 to the intercooler 18 to the support structure 34, the radiator 14 is supported by the cotter pins 64.

[0023] To remove only the radiator 14, the following procedure is carried out.

[0024] With reference to Figures 10 through 13, the support 12 is provided on its forward front part with a hole 66 facing a hole 68 of the metal flange 58 fastened to the respective distributor 28 of the condenser 16. As shown

in Figures 11, 12 and 13, a tool 70 is inserted into the holes 66, 68 on each side of the structure.

[0025] Then, the upper screws 60 that fasten the condenser 16 to the radiator 14 and the lower screws 46 that fasten the radiator 14 and the intercooler 18 to the support structure 34 of the fan assembly 20 are unscrewed and the intercooler 18 is removed. At this point, the first brackets 42 are removed, removing the screws 44, and the radiator 14 is extracted with a downwards movement. The condenser 16 is held in position by the tools 70.

[0026] From the above description, it is readily apparent that with a reduced number of fastening components it is possible to fasten to each other all the components of the front heat exchange module of the vehicle and it is possible to remove the condenser and the radiator independently from each other. Therefore, when it is necessary to remove the condenser or the radiator it is not necessary to drain the circuit of the component that does not have to be removed

Claims

1. Heat exchange module (10) for vehicles, comprising:

- a radiator (14) having two vertical and parallel collecting tanks (22),
- a condenser (16) having two parallel vertical distributor and facing a front face of the radiator (14),
- an intercooler (18) positioned underneath the condenser (16) and the radiator (14), and
- a fan assembly (20) facing a rear face of the radiator (14) and including a support structure (34) bearing at least one electric fan (36),

characterised in that:

- the radiator (14) has two upper vertical pins (26) that engage respective holes (40) provided on the support structure (34) of the fan assembly (20),
- a pair of first brackets (42) are positioned on a rear face of the support structure (34) of the fan assembly (20), the first brackets (44) being fastened by means of horizontal screws (44) to the lower part of the support structure (34) of the fan assembly, the radiator (14) and the intercooler (18) being fastened by means of screws (46) to the first brackets (42),
- a pair of second brackets (52) are fastened to the intercooler (18), the second brackets (52) being provided with respective vertical pins (56) which engage respective seats provided at the lower ends of the distributors (28) of the condenser (16), and
- the condenser (16) is fastened to the radiator (14) by means of horizontal screws (60).

2. Heat exchange module as claimed in claim 1, **characterised in that** the radiator (14) is held by means of a pair of cotter pins (64) which engage said vertical pins (26) during the removal of the condenser (16) .

5

3. Heat exchange module as claimed in claim 1, **characterised in that** the condenser (16) is capable of being held by means of auxiliary tools (70) during the disassembly of the radiator (14).

10

15

20

25

30

35

40

45

50

55

FIG. 1

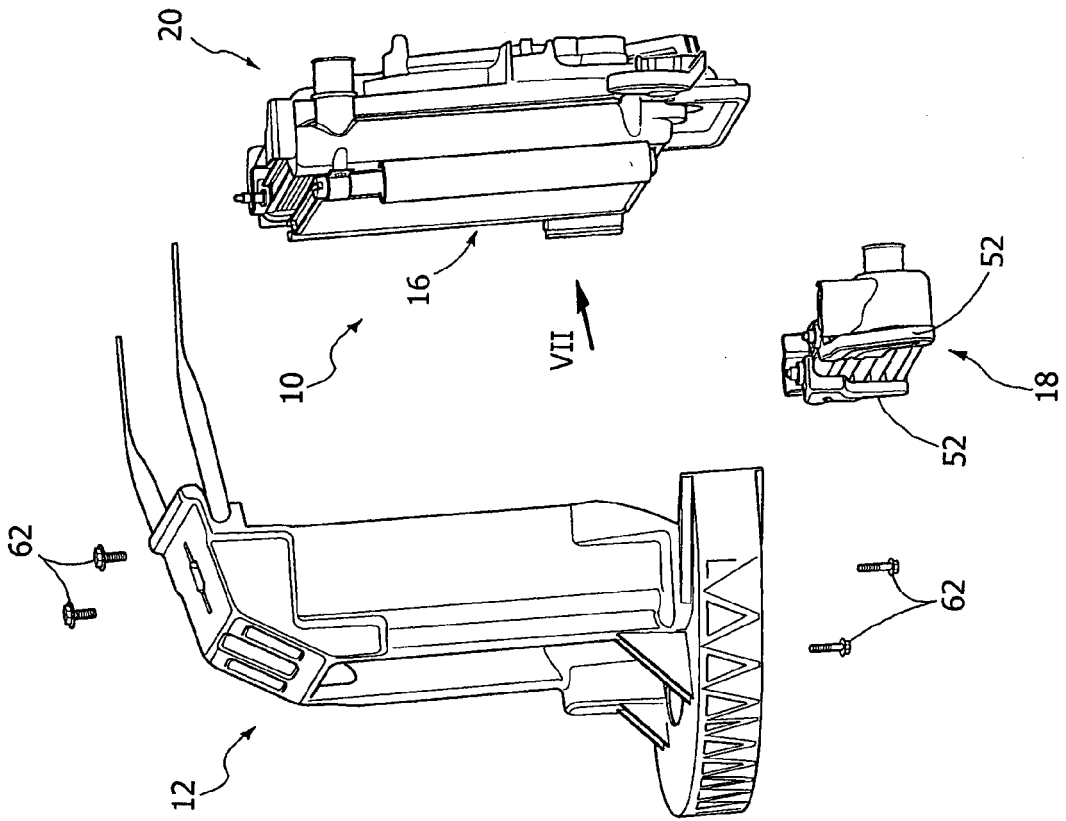

FIG. 2

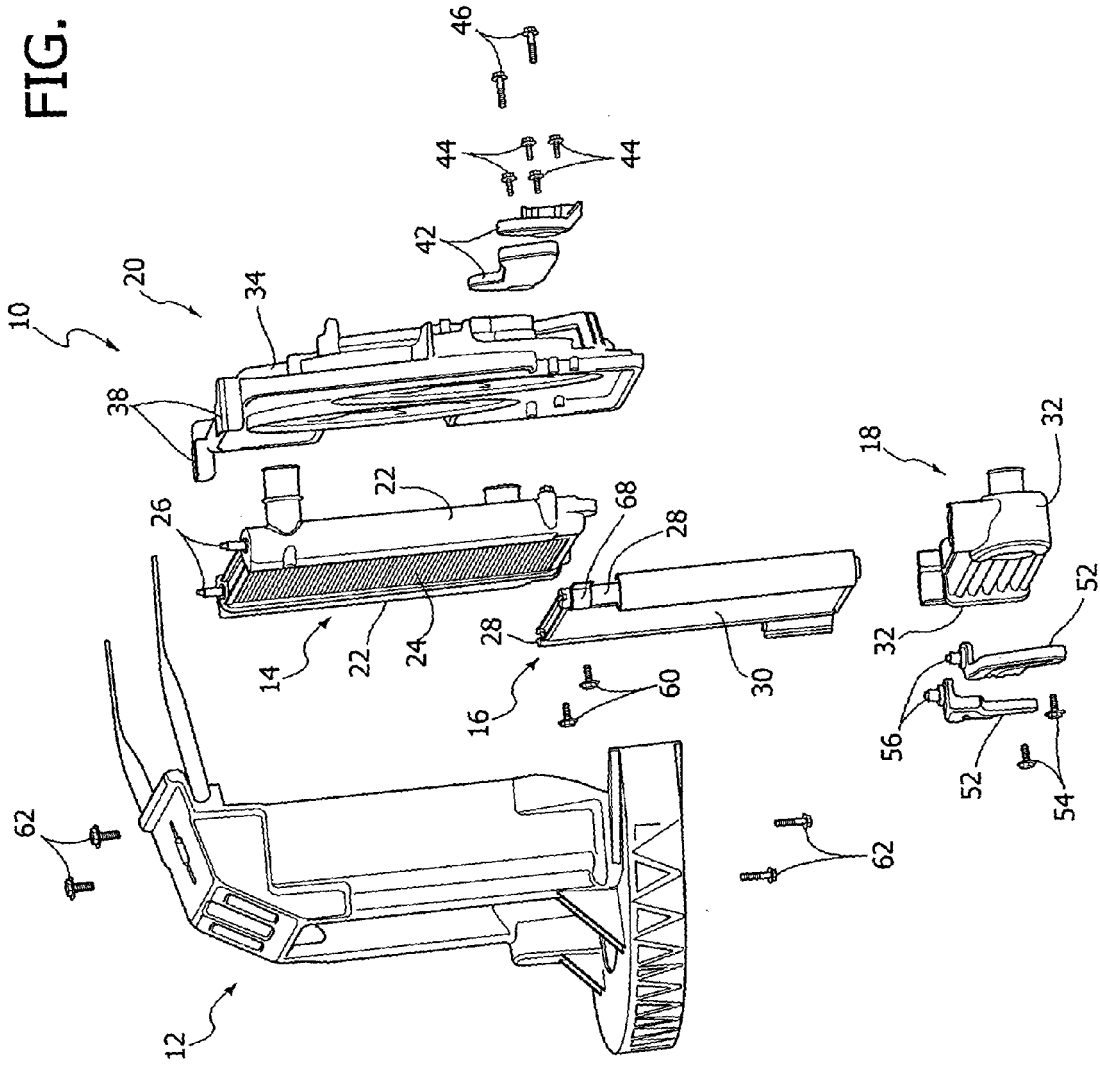

FIG. 3

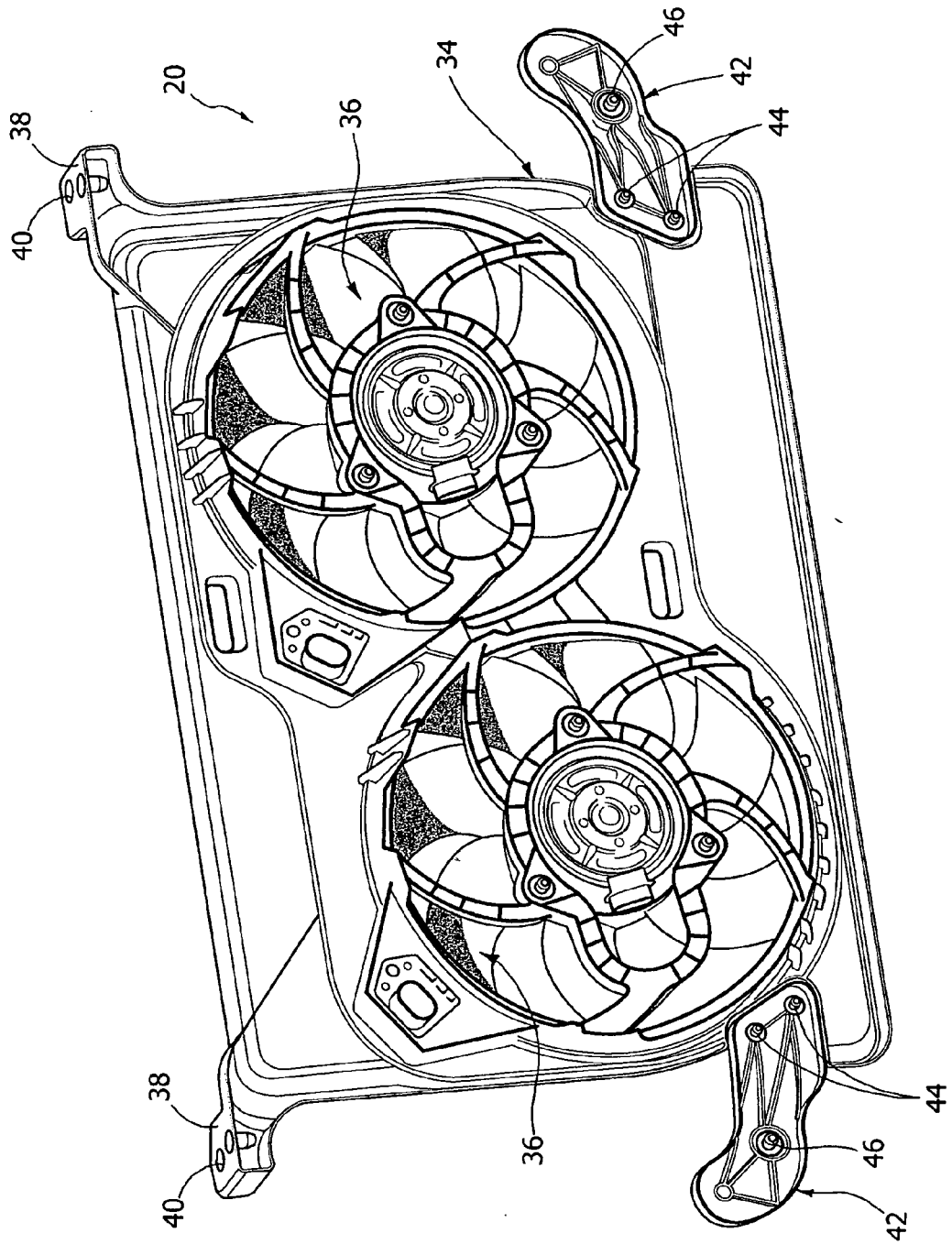

FIG. 4

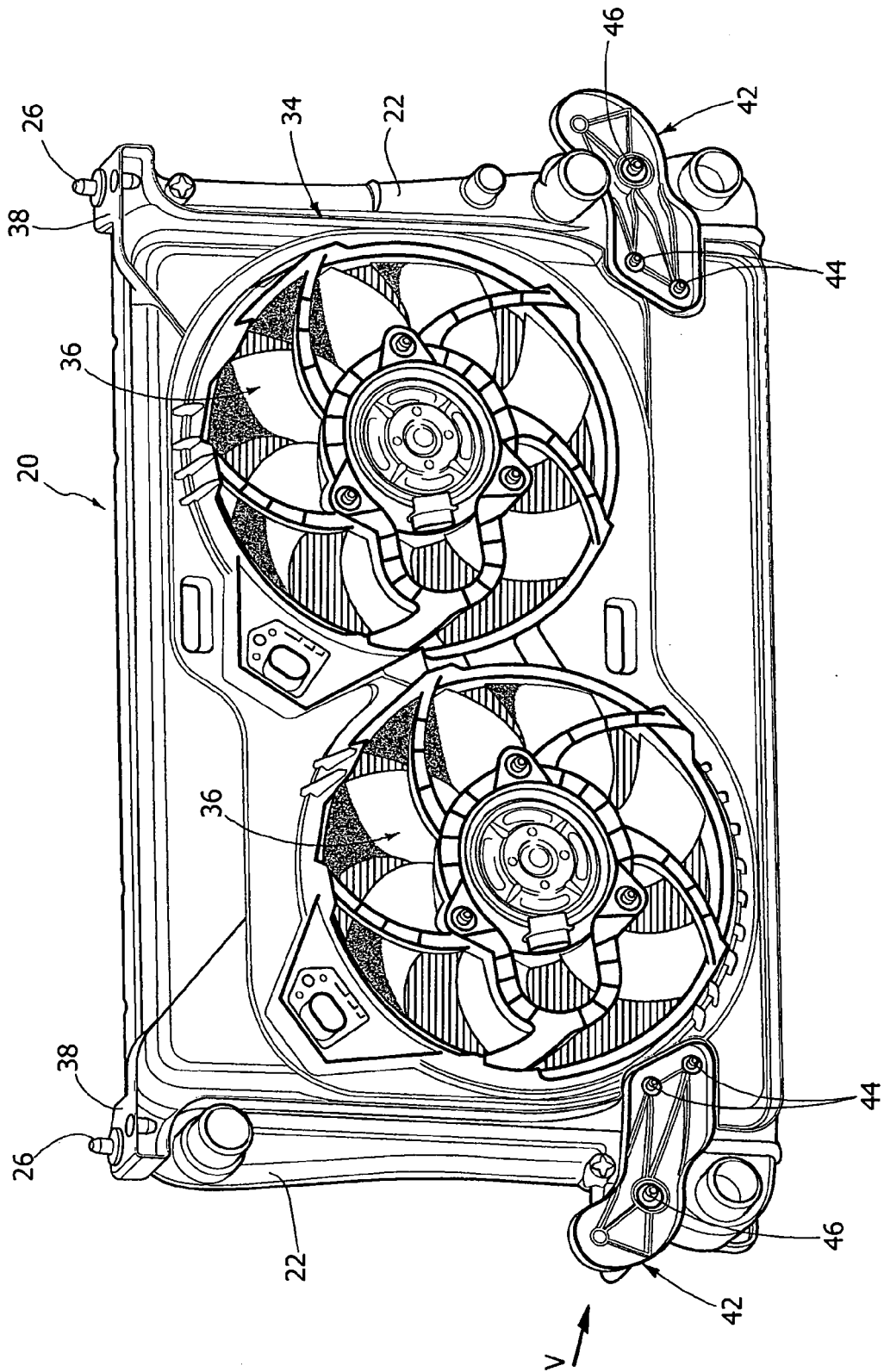

FIG. 5

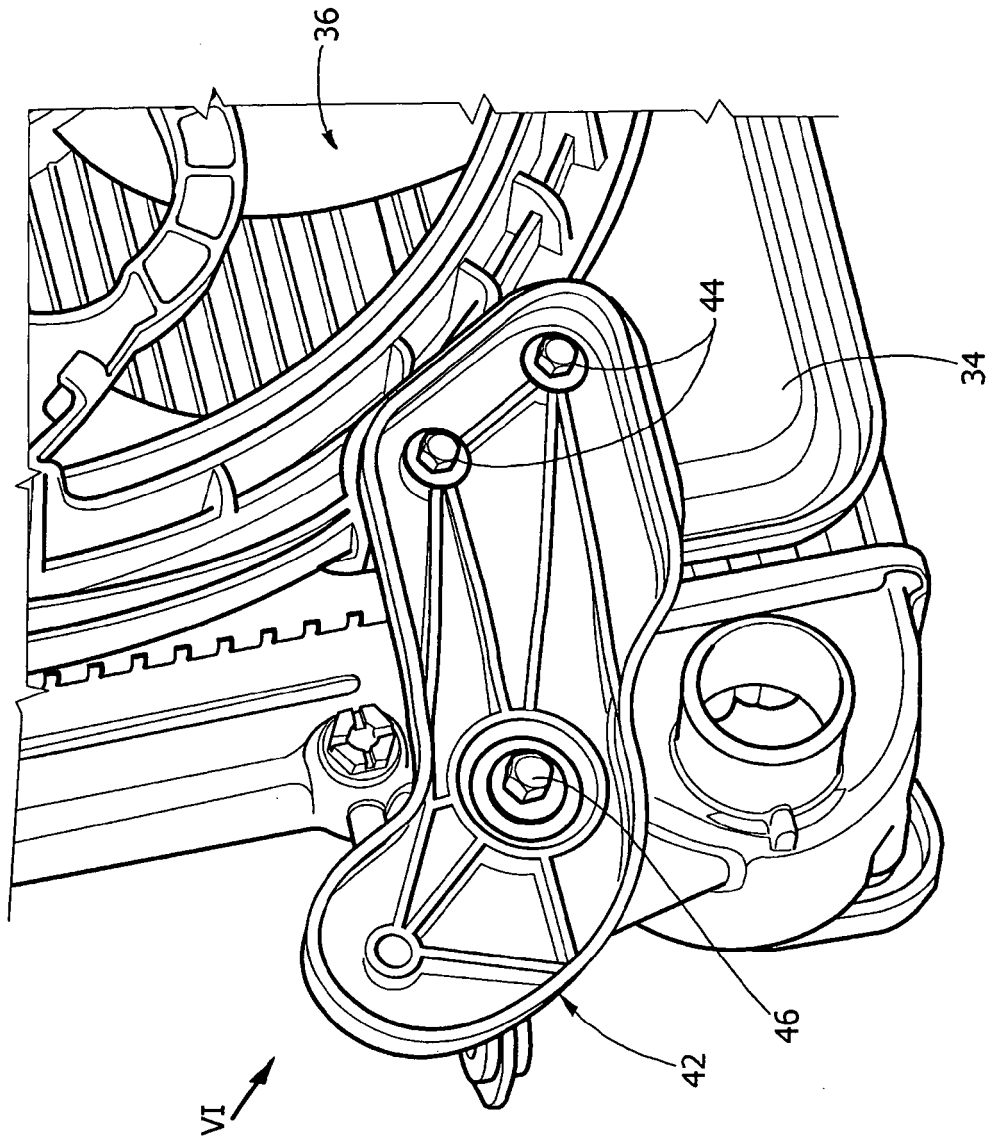

FIG. 6

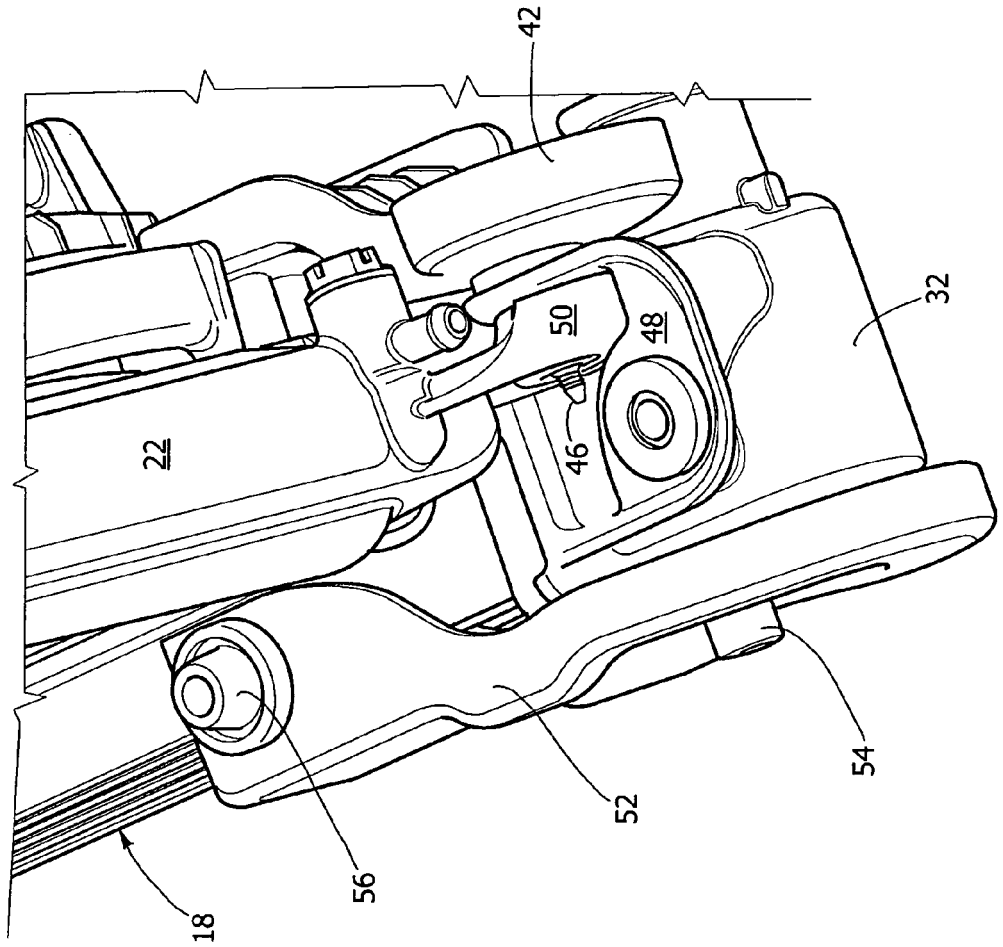

FIG. 7

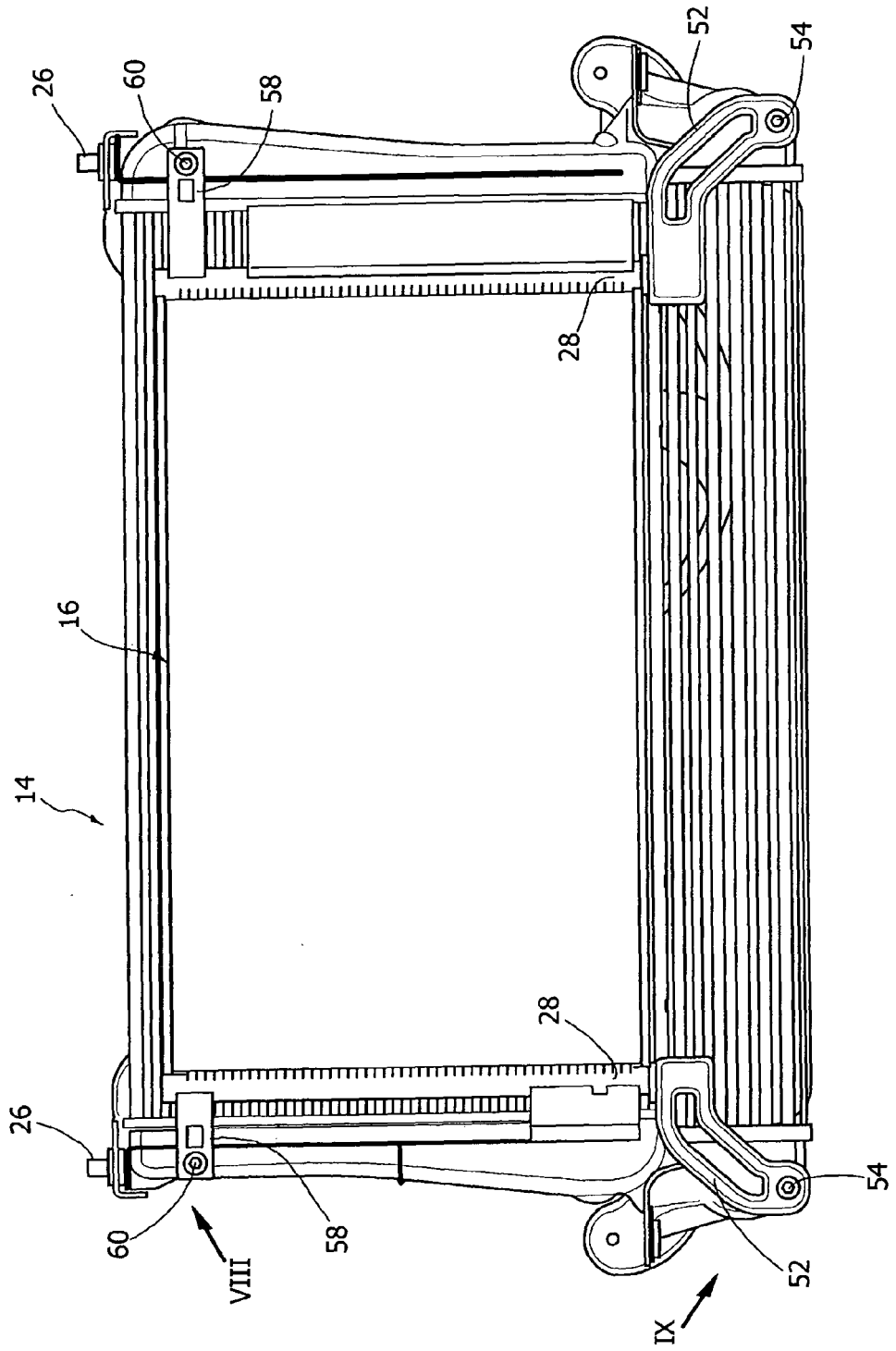

FIG. 8

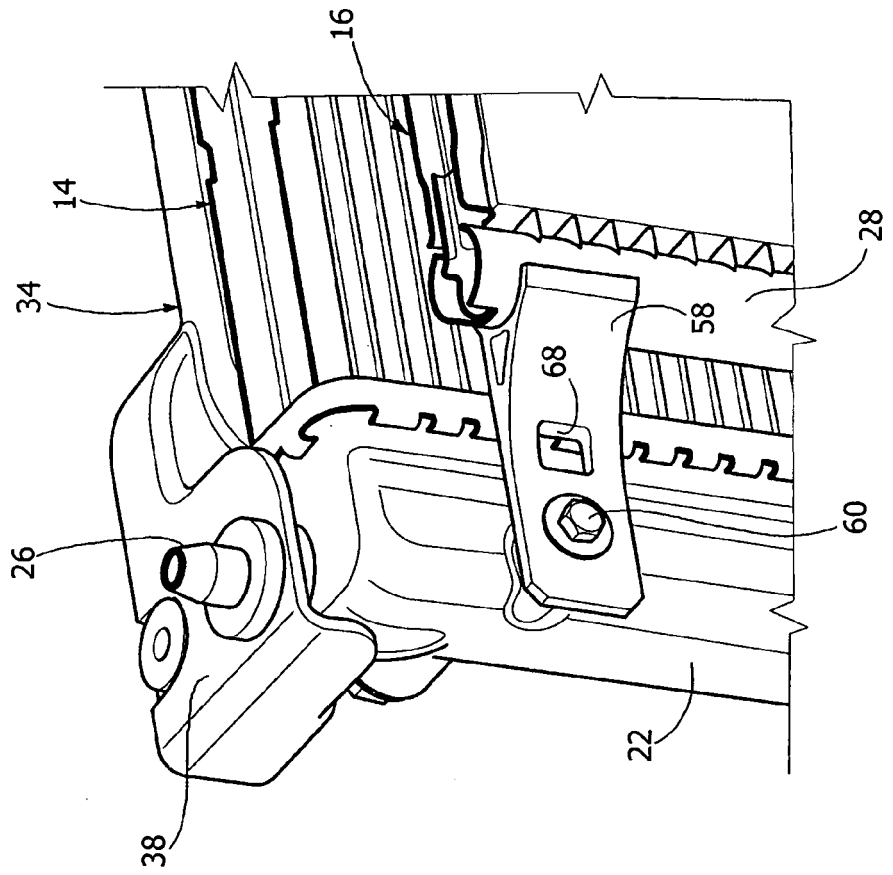

FIG. 9

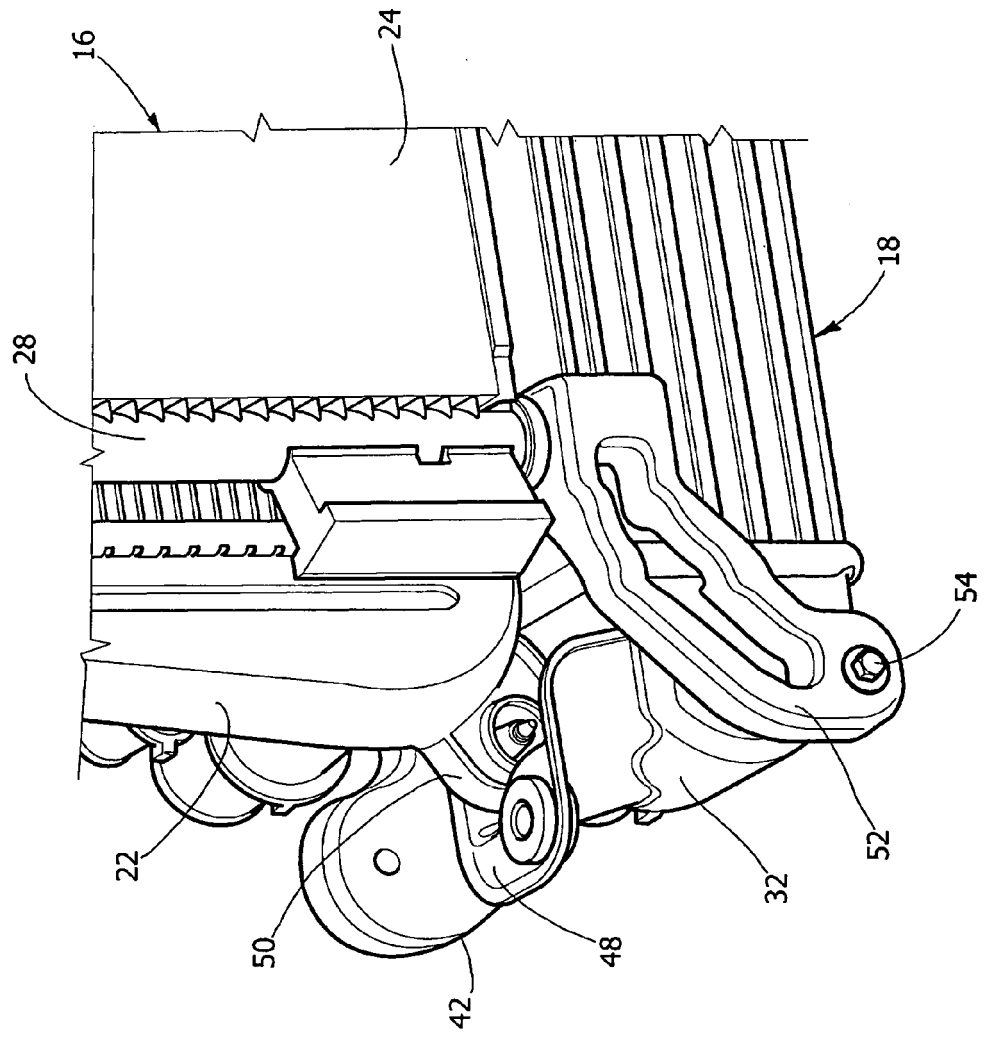

FIG. 10

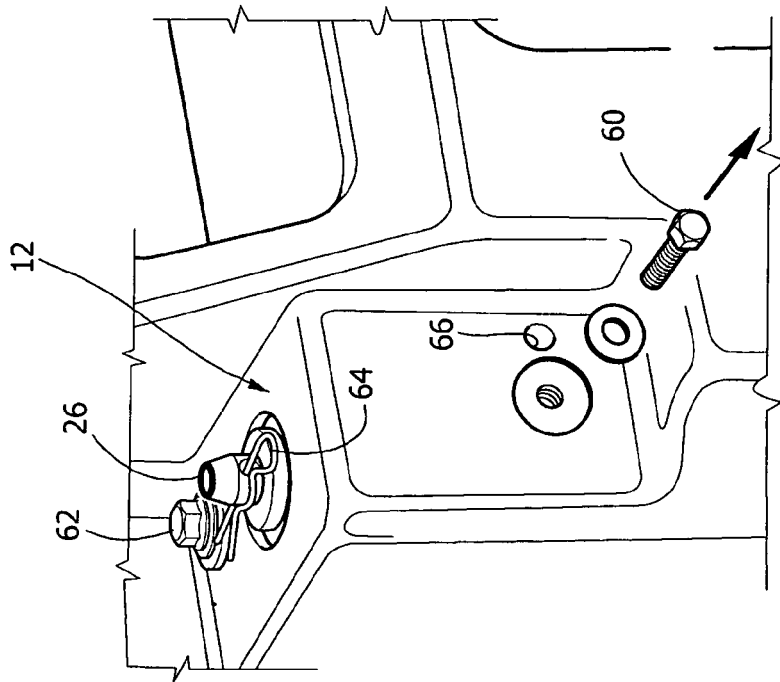

FIG. 11

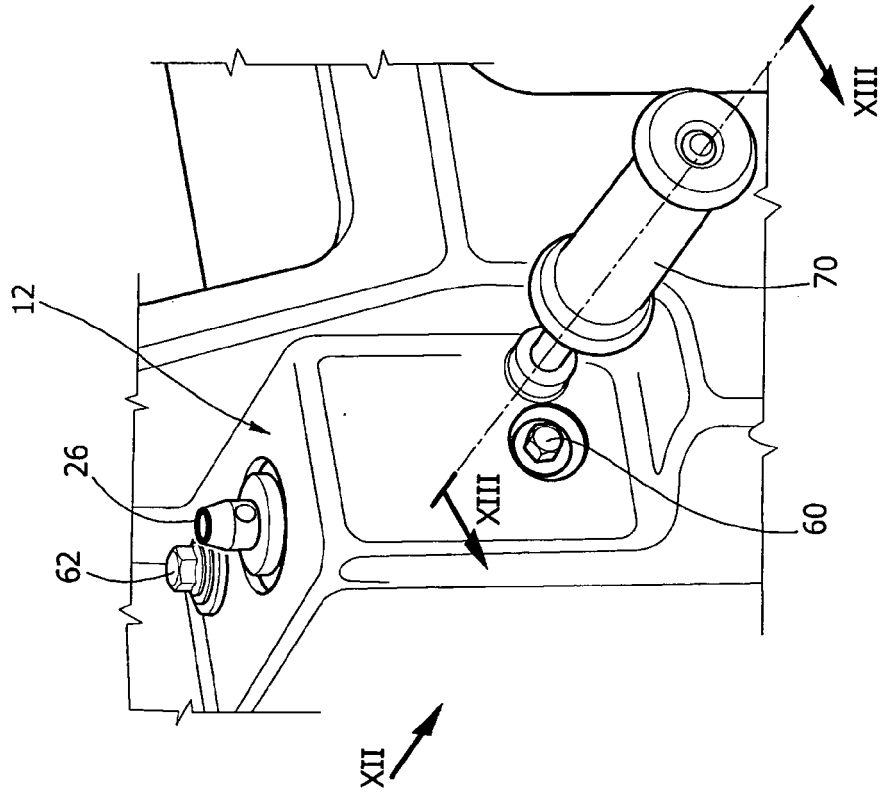

FIG. 13

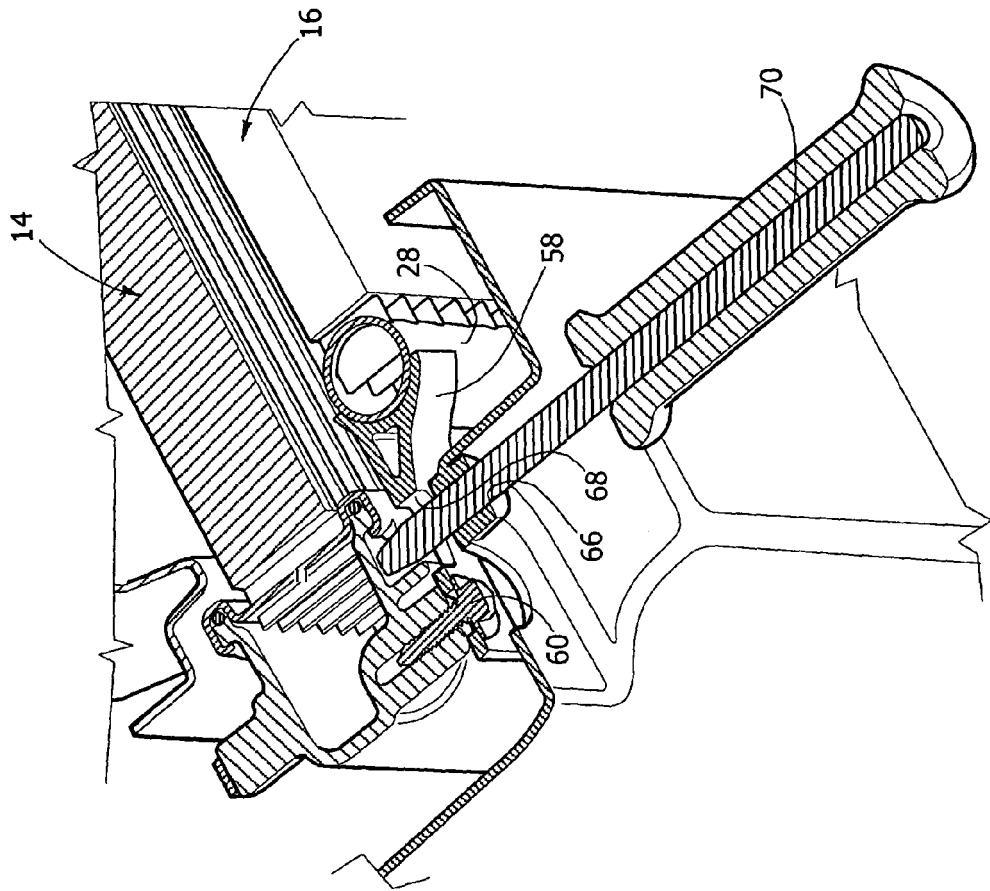
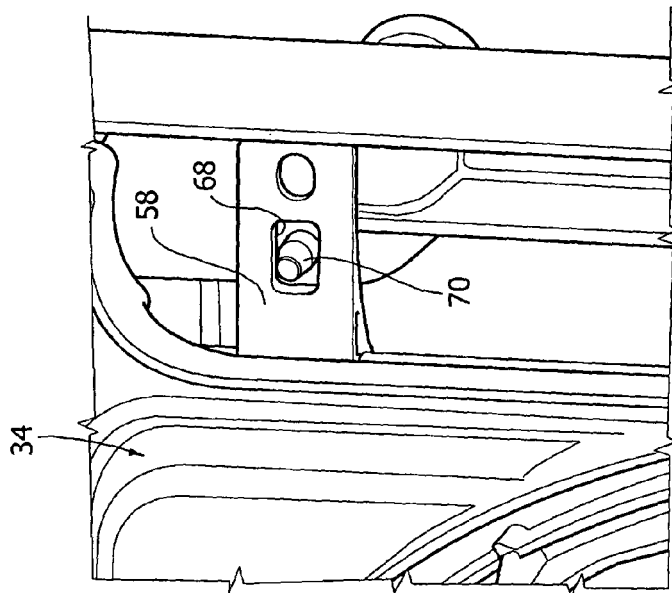

FIG. 12





DOCUMENTS CONSIDERED TO BE RELEVANT			
Category	Citation of document with indication, where appropriate, of relevant passages	Relevant to claim	CLASSIFICATION OF THE APPLICATION (IPC)
A	DE 103 44 219 A1 (BEHR GMBH & CO KG [DE]) 14 April 2005 (2005-04-14) * paragraph [0009] * * paragraph [0022] - paragraph [0023]; figures *	1-3	INV. F28D1/04 F28F9/00
A	DE 199 53 787 A1 (BEHR GMBH & CO [DE] BEHR GMBH & CO KG [DE]) 10 May 2001 (2001-05-10) * column 3, line 21 - line 45; figures *	1-3	
A	JP 2002 206893 A (TOYO RADIATOR CO LTD) 26 July 2002 (2002-07-26) * figures *	1-3	
A	FR 2 841 973 A (VALEO THERMIQUE MOTEUR [FR]) 9 January 2004 (2004-01-09) * page 10, line 29 - page 11, line 6; figure 1 *	1-3	
A	EP 1 489 375 A (MODINE MFG CO [US]) 22 December 2004 (2004-12-22) * abstract; figures *	1-3	
The present search report has been drawn up for all claims			TECHNICAL FIELDS SEARCHED (IPC)
			F28D F28F
Place of search		Date of completion of the search	Examiner
The Hague		27 November 2006	Mootz, Frank
CATEGORY OF CITED DOCUMENTS		T : theory or principle underlying the invention E : earlier patent document, but published on, or after the filing date D : document cited in the application L : document cited for other reasons & : member of the same patent family, corresponding document	
X : particularly relevant if taken alone Y : particularly relevant if combined with another document of the same category A : technological background O : non-written disclosure P : intermediate document			

1
EPO FORM 1503 03.82 (P04C01)

**ANNEX TO THE EUROPEAN SEARCH REPORT
ON EUROPEAN PATENT APPLICATION NO.**

EP 06 42 5395

This annex lists the patent family members relating to the patent documents cited in the above-mentioned European search report. The members are as contained in the European Patent Office EDP file on
The European Patent Office is in no way liable for these particulars which are merely given for the purpose of information.

27-11-2006

Patent document cited in search report	Publication date	Patent family member(s)	Publication date
DE 10344219 A1	14-04-2005	EP 1678456 A1 WO 2005033608 A1	12-07-2006 14-04-2005
DE 19953787 A1	10-05-2001	DE 19964455 B4 FR 2800863 A1	20-07-2006 11-05-2001
JP 2002206893 A	26-07-2002	NONE	
FR 2841973 A	09-01-2004	AU 2003264691 A1 EP 1532415 A2 WO 2004005830 A2 JP 2005532222 T US 2006090878 A1	23-01-2004 25-05-2005 15-01-2004 27-10-2005 04-05-2006
EP 1489375 A	22-12-2004	DE 10322211 A1 US 2004250988 A1	02-12-2004 16-12-2004

EPO FORM P0459

For more details about this annex : see Official Journal of the European Patent Office, No. 12/82