



(11) **EP 1 872 908 A3**

(12) **EUROPEAN PATENT APPLICATION**

(88) Date of publication A3:  
**04.05.2011 Bulletin 2011/18**

(51) Int Cl.:  
**B25D 11/12 (2006.01) B25D 17/26 (2006.01)**  
**F16C 3/14 (2006.01)**

(43) Date of publication A2:  
**02.01.2008 Bulletin 2008/01**

(21) Application number: **07111194.2**

(22) Date of filing: **27.06.2007**

(84) Designated Contracting States:  
**AT BE BG CH CY CZ DE DK EE ES FI FR GB GR HU IE IS IT LI LT LU LV MC MT NL PL PT RO SE SI SK TR**  
Designated Extension States:  
**AL BA HR MK RS**

(72) Inventors:  
• **Friedrich, Andreas**  
**65551, Lumburg (DE)**  
• **Frantisek, Harcar**  
**SK-08271, Lipany (SK)**

(30) Priority: **01.07.2006 GB 0613181**  
**05.07.2006 GB 0613323**

(74) Representative: **Bell, Ian Stephen et al**  
**Black & Decker**  
**Patent Department**  
**210 Bath Road**  
**Slough**  
**Berkshire SL1 3YD (GB)**

(71) Applicant: **Black & Decker, Inc.**  
**Newark, DE 19711 (US)**

(54) **A Lubricant System for a Hammer Drill**

(57) A hammer drill comprising: a piston (50) slideably mounted within a housing; a drive mechanism which converts the rotary output of the motor (32) into a reciprocating motion of the piston (50); lubrication fluid covering at least part of the drive mechanism; wherein the drive mechanism comprises: A) a crank mechanism comprising: a crank shaft (38) rotationally driven by the motor (32); and a drive pin (40) eccentrically mounted via a support structure (42) on the drive shaft (38); B) a con rod (48), one end of which being connected to the drive

pin (40) via a bearing (334), the other end being connected to the piston (50); wherein there is further provided a guide mechanism (318), in the form of a groove in the support structure which extends away from the base of the drive pin (40) towards the longitudinal axis (46) of rotation of the crank shaft (38), to direct the movement of a part of some of the lubricating fluid towards the bearing (334), the movement of that lubrication fluid being caused by the centrifugal forces acting on that lubrication fluid generated by the rotation of the crank shaft (38).

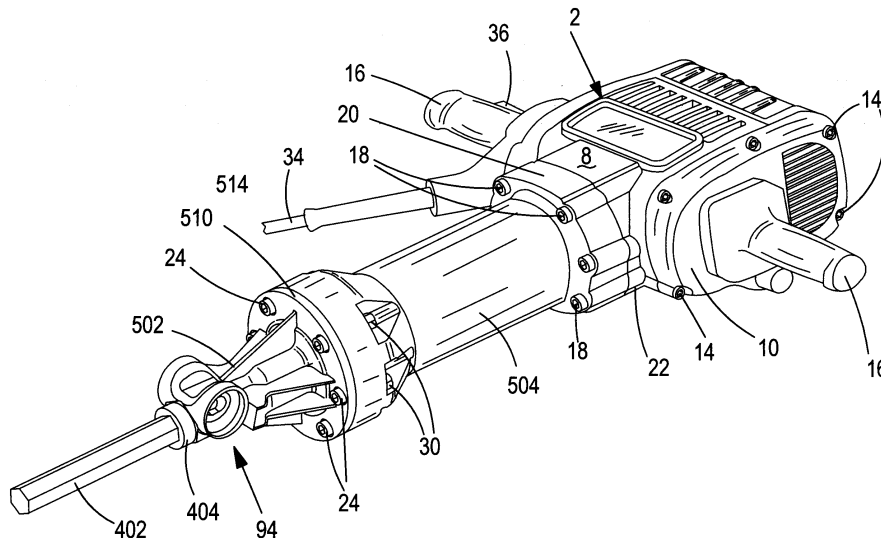

FIG. 7

**EP 1 872 908 A3**



EUROPEAN SEARCH REPORT

Application Number  
EP 07 11 1194

DOCUMENTS CONSIDERED TO BE RELEVANT			
Category	Citation of document with indication, where appropriate, of relevant passages	Relevant to claim	CLASSIFICATION OF THE APPLICATION (IPC)
X	WO 03/024671 A2 (MILWAUKEE ELECTRIC TOOL CORP [US]) 27 March 2003 (2003-03-27) * page 5, line 25 - page 10, line 17; figures 1,5 *	1	INV. B25D11/12 B25D17/26 F16C3/14
A	----- US 3 162 268 A (SHORT HAROLD O.) 22 December 1964 (1964-12-22) * the whole document *	1	
A	----- US 2 239 090 A (EVERETT LUCIUS T) 22 April 1941 (1941-04-22) * the whole document *	1	
A	----- GB 290 611 A (GIUSTINO CATTANEO) 22 November 1928 (1928-11-22) * the whole document *	1	
			TECHNICAL FIELDS SEARCHED (IPC)
			B25D F16C
The present search report has been drawn up for all claims			
Place of search		Date of completion of the search	Examiner
The Hague		28 March 2011	Lorence, Xavier
CATEGORY OF CITED DOCUMENTS			
X : particularly relevant if taken alone Y : particularly relevant if combined with another document of the same category A : technological background O : non-written disclosure P : intermediate document		T : theory or principle underlying the invention E : earlier patent document, but published on, or after the filing date D : document cited in the application L : document cited for other reasons ..... & : member of the same patent family, corresponding document	

1  
EPO FORM 1503 03.82 (P04C01)

**ANNEX TO THE EUROPEAN SEARCH REPORT  
ON EUROPEAN PATENT APPLICATION NO.**

EP 07 11 1194

This annex lists the patent family members relating to the patent documents cited in the above-mentioned European search report. The members are as contained in the European Patent Office EDP file on  
The European Patent Office is in no way liable for these particulars which are merely given for the purpose of information.

28-03-2011

Patent document cited in search report	Publication date	Patent family member(s)	Publication date
WO 03024671	A2	27-03-2003	AU 2002326946 A1 01-04-2003
			CN 1551816 A 01-12-2004
			DE 10294312 T5 02-09-2004
			GB 2384742 A 06-08-2003
-----			
US 3162268	A		NONE
-----			
US 2239090	A	22-04-1941	NONE
-----			
GB 290611	A	22-11-1928	NONE
-----			

EPO FORM P0489

For more details about this annex : see Official Journal of the European Patent Office, No. 12/82