



(11) **EP 1 882 809 B1**

(12) **EUROPEAN PATENT SPECIFICATION**

(45) Date of publication and mention of the grant of the patent:  
**13.04.2011 Bulletin 2011/15**

(51) Int Cl.:  
**E21B 47/00 (2006.01)**

(21) Application number: **06291222.5**

(22) Date of filing: **24.07.2006**

(54) **Methods and apparatus for micro-imaging**

Verfahren und Vorrichtung für Mikrobildgebung

Procédés et appareil de micro-imagerie

(84) Designated Contracting States:  
**AT BE BG CH CY CZ DE DK EE ES FI FR GB GR HU IE IS IT LI LT LU LV MC NL PL PT RO SE SI SK TR**

(43) Date of publication of application:  
**30.01.2008 Bulletin 2008/05**

(73) Proprietors:

- **Services Pétroliers Schlumberger**  
**75007 Paris (FR)**  
Designated Contracting States:  
**FR**
- **Schlumberger Technology B.V.**  
**2514 JG The Hague (NL)**  
Designated Contracting States:  
**BG CZ DE DK GR HU IE IT LT PL RO SI SK TR**
- **Schlumberger Holdings Limited**  
**Road Town, Tortola (VG)**  
Designated Contracting States:  
**GB NL**
- **PRAD Research and Development N.V.**  
**Willemstad, Curacao (AN)**  
Designated Contracting States:  
**AT BE CH CY EE ES FI IS LI LU LV MC PT SE**

(72) Inventor: **Rezgui, Fadhel**  
**92320 Chatillon (FR)**

(74) Representative: **Hyden, Martin Douglas et al**  
**Etudes et Productions Schlumberger**  
**Intellectual Property Department**  
**1 rue Henri Becquerel**  
**B.P. 202**  
**92142 Clamart Cedex (FR)**

(56) References cited:

<b>EP-A- 0 747 569</b>	<b>EP-A- 1 388 615</b>
<b>WO-A-2004/003506</b>	<b>WO-A-2005/116401</b>
<b>DD-A- 100 517</b>	<b>GB-A- 2 345 753</b>
<b>US-A- 3 992 095</b>	

**EP 1 882 809 B1**

Note: Within nine months of the publication of the mention of the grant of the European patent in the European Patent Bulletin, any person may give notice to the European Patent Office of opposition to that patent, in accordance with the Implementing Regulations. Notice of opposition shall not be deemed to have been filed until the opposition fee has been paid. (Art. 99(1) European Patent Convention).

## Description

### Technical field

**[0001]** This invention relates to methods and apparatus for imaging underground formations and fluids such as are commonly encountered in the drilling of wells such as oil and gas wells. In particular, the invention provides apparatus for use as a tool for making measurements in such wells.

### Background art

**[0002]** There are a number of techniques that have been proposed for obtaining images of underground formations around boreholes. In some of these techniques, small-scale electrical, acoustic or nuclear properties are measured and an image reconstructed from these measurements. In all of these cases, the image is inferred: it does not correspond exactly to what a person would see if viewing it directly.

**[0003]** A number of optical techniques have also been proposed for viewing the formation surrounding a borehole. In one such technique, the borehole is filled with an optically clear fluid (water or oil), and a tool carrying a camera and light source is passed along the borehole. Conical or hemispherical mirrors or fish-eye lenses have been proposed to obtain full azimuthal coverage for a camera placed at or near the centre line of the borehole.

**[0004]** In another class of optical techniques an optical window is provided in the side of a tool or pad which is pressed against the borehole wall and measurements made.

**[0005]** All of these optical techniques suffer from problems. In all cases, the formation viewed is that left after the drilling operation has been performed. It is well known that drilling can cause significant changes in the formation around a borehole. For example, the drilling action can cause mechanical damage, and drilling fluids can enter the formations (invasion) or cause the formations to undergo changes such as swelling. Consequently, viewing such a formation may not be a good way to understand the nature of the formation in its normal state. The typical imaging resolution is of the order of 1 cm.

**[0006]** Another problem is that borehole fluids, formation fluids or mudcake can coat the viewing window or get between the window and the formation and prevent an image being obtained.

**[0007]** This invention is aimed at solving the problem of investigating the formation in a regions that are less effected by the drilling process and in a manner that avoids problems with contaminant coming between the imaging tool and the formation preventing an image being obtained.

### Disclosure of the invention

**[0008]** A first aspect of the invention provides an ap-

paratus for investigating underground formations surrounding a borehole, comprising:

- a drill bit;
- an optical probe having substantially the same outer diameter as the drill bit;
- a drive mechanism, operable to cause the drill bit to drill a hole in the formation when the apparatus is in the borehole, and to advance the optical probe into the drilled hole; and
- an optical system, arranged such that when the optical probe is in the drilled hole, light from a light source is directed into the optical probe, light entering the probe from the source is directed at the formation around the drilled hole, and light entering the probe from the formation around the drilled hole is directed to a detector.

**[0009]** By providing an optical probe with substantially the same diameter as the drill bit, the optical surface of the probe can be held close enough to the formation in the drilled hole that the level of degradation due to material between the probe and the formation is sufficiently low as to allow effective investigation of the formation. Drilling into the formation means that the formation 'viewed' by the tool is less affected by the drilling process.

**[0010]** In one preferred embodiment, the drill bit and optical probe form a single, elongate probe unit. In this case, it is preferred that the drill bit is mounted on the end of the optical probe. The optical system can comprise a conical mirror located at the joint between the drill bit and optical probe.

**[0011]** Where the drill bit and optical probe are provided in one unit, the drive mechanism can be arranged to act on the optical probe to cause the drill bit to drill the hole.

**[0012]** In one preferred form of this embodiment, the drill bit is provided with a liquid pathway to direct any formation fluid entering the drilled hole back along the probe unit. The liquid path typically leads to a capillary trap in the probe unit at which the fluid can be analysed.

**[0013]** In another embodiment of the invention, the drill bit and optical probe are two discrete units. In this case, the optical system can comprise a conical mirror located in the optical probe.

**[0014]** In this embodiment, the drive mechanism preferably includes means for aligning the drill bit or the optical probe with the position of the drilled hole.

**[0015]** Apparatus according to the invention preferably further comprises a tool body in which are located the drive mechanism, a light source and a detector and at least part of the optical system. The body can also include arms which can be operated to bear against the borehole wall so as to urge the tool body against the part of the borehole wall into which the hole is to be drilled.

**[0016]** A second aspect of the invention provides a method of investigating underground formations surrounding a borehole, comprising:

- drilling a hole in the formation to be investigated using a drill bit;
- inserting an optical probe having substantially the same outer diameter as the drill bit into the hole;
- directing light from a light source to the probe;
- directing light entering the optical probe to the formation around the drilled hole;
- directing light entering the optical probe from the formation to a detector; and
- analysing the light received at the detector.

**[0017]** The optical probe can be used to turn the drill bit such that as the drill bit drills into the formation, the optical probe is inserted into the drilled hole.

**[0018]** By partially withdrawing the drill bit in the drilled hole, fluids can be drawn from the formation into the drilled hole. In this case, the method preferably further comprises drawing the fluids along the drill bit to the optical probe and analysing the fluids using the optical probe.

**[0019]** In another embodiment of the method according to the invention, after drilling the hole using the drill bit, the drill bit is withdrawn from the hole and the optical probe subsequently inserted.

**[0020]** The method according to the second aspect of the invention is preferably performed using an apparatus according to the first aspect of the invention.

#### Brief description of the drawings

**[0021]** Figures 1 and 2 show a tool according to a first embodiment of the invention;

Figure 3 shows a detailed view of the drill probe unit of the embodiment of Figures 1 and 2;

Figure 4 shows the drill probe of Figure 3 when used for fluid analysis;

Figures 5 and 6 show a tool according to a second embodiment of the invention; and

Figure 7 shows a detailed view of the optical probe of the embodiment of Figures 5 and 6.

#### Mode(s) for carrying out the invention

**[0022]** Figures 1 and 2 show a first embodiment of a tool according to the invention. The tool comprises a tool body 10 that can be suspended in a borehole 12 by means of a wireline cable (not shown) which provides power and data communication from the surface. A pair of backup arms 14 are mounted on the tool body and can be extended to contact one side of the borehole wall 16 so as to force the tool body 10 against the opposite side of the borehole wall 18 where it is supported on pads 20.

**[0023]** A drive mechanism 22 comprising a motor and gear arrangement is mounted in the body 10. The drive mechanism includes a drive head 24 in which is mounted a drill and probe unit 26. The unit 26 comprises at its outer end a drill bit 28 and at its inner end an optical probe

30 formed from a sapphire fibre having an outside diameter that is substantially the same as, but no larger than that of the drill bit. The drive mechanism 24, which is provided with power and control signals from the wireline cable, operates to rotate the drill unit 26 and provide an axial drive to either drill into the borehole wall 18 or withdraw the unit from a drilled hole.

**[0024]** The body 10 also contains an optical system comprising a CCD camera and light source 32 with associated control electronics 34. The optical system also includes a mirror 36 which provides a light path 38 to direct light from the light source into the fibre forming the optical probe 30, and to direct light exiting the optical probe to the CCD camera.

**[0025]** Figure 1 shows the configuration of the tool when it is positioned in the borehole 12 adjacent a formation of interest. Figure 2 shows the configuration of the tool once a hole has been drilled and the drill and probe unit 26 advanced into the drilled hole such that at least the lower part of the optical probe 30 is located in the hole.

**[0026]** Figure 3 shows further detail of the drill and probe unit 26. The drill bit 28 is metallic and has an end portion 40 for drilling ahead and a tail portion 42 which is shaped with grooves 44 to remove the drilled material, and to polish or hone the wall of the drilled hole to obtain a good surface for imaging. The sapphire fibre 46 forming the optical probe 30 is fixed to the end of the drill bit 28. The outer diameter of the fibre 46 is close to, but no greater than the largest outer diameter of any part of the drill bit 28 (for example 5-12mm) so as to be able to fit in the drilled hole but to leave as little possible space between the wall of the drilled hole and the side of the fibre 46. This has the effect of minimising the amount of material that can remain between the side of the fibre 46 and the wall of the drilled hole which could otherwise interfere with optical measurements. Grooves 44', corresponding to those in the drill bit 28 are formed in the outer surface of the fibre 46 to direct drilled material out of the hole and away from the wall to be imaged.

**[0027]** A conical mirror 48 is formed at the interface between the drill bit 28 and optical probe 30. Light entering the probe from the source 32 via the mirror 36 is reflected substantially equally around the azimuth of the fibre 46 onto an investigation zone 50 of the hole wall near the conical mirror 48. Light passing into the fibre from the investigation zone 50 is reflected by the conical mirror 48 back up the fibre 46 and via the mirror 36 to the CCD camera 32. Thus, light from the source 32 can be directed at the polished or honed surface of the drilled hole in the investigation zone 50 and an optical image of the wall (and hence the formation) returned to the camera 32. Such a probe can be used to obtain optical images on the order of 1 micron resolution.

**[0028]** As well as the optical image, the drill and probe unit 26 to analyse formation fluids as is shown in Figure 4. Because of the close fit between the outside of the probe unit 26 and the wall of the drilled hole, when the

probe unit 26 is withdrawn from the hole, a pressure drop is created at the end of the hole 52 by the swabbing effect such that fluids can flow in from the formation 18. The fluids can flow back along the grooves 44 and 44' to the region of the fibre 46 near the mirror 48 where they can be trapped in a capillary chamber 54 and optically analysed in a similar fashion to that described above for the formation wall.

**[0029]** The steps of drilling, imaging and fluid analysis can be repeated several times, repositioning the tool in the borehole prior to each measurement.

**[0030]** Figures 5 and 6 show a second embodiment of a tool according to the invention. Parts corresponding to those in Figures 1 and 2 are given the same numbers in the 100 series.

**[0031]** This second embodiment differs from the first in that the drill probe unit is replaced by a separate drill bit 128 and optical probe 130. In this case, the drive head 124 has the bit 128 and probe 130 carried separately and the drive mechanism 122 includes a translation mechanism to align one or the other with the position of the drilled hole.

**[0032]** In the first stage or operation, as shown in Figure 5, the tool is positioned as before and the drive mechanism 122 operated to drill the hole with the drill bit 128. The mechanism 122 then withdraws the bit 128 from the hole and moves the drive head 124 until the optical probe 130 is aligned with the hole (Figure 6), at which point it is inserted into the hole and the optical measurement made. The probe 130 can then be withdrawn from the hole and the tool moved to another location for further measurements to be made.

**[0033]** In this embodiment, the optical probe can have a somewhat different construction as is shown in Figure 7, comprising a multi-part sapphire-sapphire assembly 60, 62 having a conical mirror 64 formed at the interface. Again, a probe diameter corresponding to that of the OD of the drill bit 128 is used, 5-12mm for example.

**[0034]** In both embodiments, the light returning to the CCD camera 32 can be processed in the tool electronics 34 to form images which can be either stored in the tool or transmitted to the surface via the wireline cable. Also, the raw optical signals can be stored or transmitted to the surface for later processing.

**[0035]** Other changes can be made while staying within the scope of the invention. For example, the tool can be self contained without the need to rely on the wireline cable for instructions and/or power. The tool can also be conveyed on coiled tubing. While the examples given above contemplate imaging in open (uncased) boreholes, the invention could also be used in cased boreholes but with the necessity of drilling through casing and any cement between the casing and formation before obtaining images. Plugging of holes drilled in casing may also be required.

**[0036]** In another embodiment, the optical probe is provided with a small internal hole that can be connected in the tool body to a pumping arrangement. This hole can

be used for the withdrawal of liquid from the drilled hole in order to measure the formation pressure. The hole can also be used to inject a very small quantity of liquid (water for instance) in order to flush the probe in cases where the optical attenuation is high, for example in heavy mud. Since the amount of liquid surrounding the probe in the drilled hole (for the dimensions described above) is very small (about one cc) it can easily be replaced or diluted with a clean fluid ejected from the hole in the probe.

## Claims

1. Apparatus for investigating underground formations surrounding a borehole, comprising:
  - a drill bit (28);
  - an optical probe (30) having substantially the same outer diameter as the drill bit;
  - a drive mechanism (22), operable to cause the drill bit to drill a hole in the formation when the apparatus is in the borehole, and to advance the optical probe into the drilled hole; and
  - an optical system, arranged such that when the optical probe is in the drilled hole, light from a light source (32) is directed into the optical probe, light entering the probe from the source is directed at the formation around the drilled hole, and light entering the probe from the formation around the drilled hole is directed to a detector.
2. Apparatus as claimed in claim 1, wherein the drill bit and optical probe form a single, elongate probe unit.
3. Apparatus as claimed in claim 2, wherein the drill bit is mounted on the end of the optical probe.
4. Apparatus as claimed in claim 3, wherein the optical system comprises a conical mirror (48) located at the joint between the drill bit and optical probe.
5. Apparatus as claimed in any of claims 2-4, wherein the drive mechanism acts on the optical probe to cause the drill bit to drill the hole.
6. Apparatus as claimed in any of claims 2-5, wherein the drill bit is provided with a liquid pathway to direct any formation fluid entering the drilled hole back along the probe unit.
7. Apparatus as claimed in claim 6, wherein the liquid path leads to a capillary trap in the probe unit at which the fluid can be analysed.
8. Apparatus as claimed in claim 1, wherein the drill bit and optical probe are two discrete units.

9. Apparatus as claimed in claim 8, wherein the optical system comprises a conical mirror (48) located in the optical probe.
10. Apparatus as claimed in claim 8 or 9, wherein the drive mechanism includes means for aligning the drill bit or the optical probe with the position of the drilled hole.
11. Apparatus as claimed in any preceding claim, further comprising a tool body in which are located the drive mechanism, a light source and a detector and at least part of the optical system.
12. Apparatus as claimed in claim 11, wherein the body also includes arms (14) which can be operated to bear against the borehole wall so as to urge the tool body against the part of the borehole wall into which the hole is to be drilled.
13. Apparatus as claimed in any preceding claim, wherein the optical probe further comprises a bore through which fluids can be withdrawn from or pumped into the drilled hole.
14. A method of investigating underground formations surrounding a borehole, comprising:
- drilling a hole in the formation to be investigated using a drill bit (28);
  - inserting an optical probe (30) having substantially the same outer diameter as the drill bit into the hole;
  - directing light from a light source to the probe;
  - directing light entering the optical probe to the formation around the drilled hole;
  - directing light entering the optical probe from the formation to a detector; and
  - analysing the light received at the detector.
15. A method as claimed in claim 14, comprising using the optical probe to turn the drill bit such that as the drill bit drills into the formation, the optical probe is inserted into the drilled hole,
16. A method as claimed in claim 15, further comprising at least partially withdrawing the drill bit in the drilled hole so as to draw fluids from the formation into the drilled hole.
17. A method as claimed in claim 16, further comprising drawing the fluids along the drill bit to the optical probe and analysing the fluids using the optical probe.
18. A method as claimed in claim 14, comprising, after drilling the hole using the drill bit, withdrawing the drill bit from the hole and subsequently inserting the

optical probe.

19. A method as claimed in claim 14, when performed using an apparatus as claimed in any of claims 1-13.

### Patentansprüche

1. Vorrichtung zum Untersuchen unterirdischer, ein Bohrloch umgebender Formationen, umfassend:
- eine Bohrkronen (28);
  - eine im Wesentlichen den gleichen Außendurchmesser wie die Bohrkronen aufweisende optische Sonde (30);
  - einen Antriebsmechanismus (22), der betätigbar ist, um mit der Bohrkronen ein Loch in die Formation zu bohren, wenn die Vorrichtung in dem Bohrloch ist, und die optische Sonde in dem gebohrten Loch vorzurücken; und
  - ein optisches System, das derart angeordnet ist, dass, wenn die optische Sonde in dem gebohrten Loch ist, Licht von einer Lichtquelle (32) in die optische Sonde gelenkt wird, das in die Sonde eintretende Licht der Quelle auf die Formation um das gebohrte Loch gelenkt wird, und das in die Sonde eintretende Licht von der Formation um das gebohrte Loch auf einen Detektor gelenkt wird.
2. Vorrichtung nach Anspruch 1, wobei die Bohrkronen und die optische Sonde eine einzige langgestreckte Sondeneinheit bilden.
3. Vorrichtung nach Anspruch 2, wobei die Bohrkronen an dem Ende der optischen Sonde befestigt ist.
4. Vorrichtung nach Anspruch 3, wobei das optische System einen konischen Spiegel (48) umfasst, der an der Verbindung zwischen der Bohrkronen und der optischen Sonde positioniert ist.
5. Vorrichtung nach einem der Ansprüche 2-4, wobei der Antriebsmechanismus auf die optische Sonde wirkt, um die Bohrkronen das Loch bohren zu lassen.
6. Vorrichtung nach einem der Ansprüche 2-5, wobei die Bohrkronen mit einem Flüssigkeitsdurchgang versehen ist, um irgendein Formationsfluid, das in das gebohrte Loch eintritt, zurück längs der Sondeneinheit zu lenken.
7. Vorrichtung nach Anspruch 6, wobei der Flüssigkeitsgang zu einer Kapillarfall in der Sondeneinheit führt, bei der das Fluid analysierbar ist.
8. Vorrichtung nach Anspruch 1, wobei die Bohrkronen und die optische Sonde zwei diskrete Einheiten sind.

9. Vorrichtung nach Anspruch 8, wobei das optische System einen konischen Spiegel (48) umfasst, der in der optischen Sonde lokalisiert ist.
10. Vorrichtung nach Anspruch 8 oder 9, wobei der Antriebsmechanismus Mittel zum Ausrichten der Bohrkronen oder der optischen Sonde auf die Position des gebohrten Lochs umfasst.
11. Vorrichtung nach einem vorhergehenden Anspruch, ferner umfassend einen Werkzeugkörper, in dem der Antriebsmechanismus, eine Lichtquelle und ein Detektor sowie wenigstens ein Teil des optischen Systems lokalisiert sind.
12. Vorrichtung nach Anspruch 11, wobei der Körper auch Arme (14) beinhaltet, die betätigbar sind, um gegen die Bohrlochwand zu drücken, um den Werkzeugkörper gegen den Teil der Bohrlochwand zu pressen, in den das Loch zu bohren ist.
13. Vorrichtung nach einem vorhergehenden Anspruch, wobei die optische Sonde ferner eine Bohrung umfasst, durch die Fluide aus dem gebohrten Loch gezogen oder in das gebohrte Loch gepumpt werden können.
14. Verfahren zum Untersuchen von ein Bohrloch umgebenden unterirdischen Formationen, umfassend:
- Bohren eines Lochs in die zu untersuchende Formation unter Verwendung einer Bohrkronen (28);
  - Einsetzen einer optischen Sonde (30) in das Loch, die im Wesentlichen den gleichen Außendurchmesser wie die Bohrkronen aufweist;
  - Lenken von Licht von einer Lichtquelle zur Sonde;
  - Lenken von in die optische Sonde eintretendem Licht zu der Formation, die das gebohrte Loch umgibt;
  - Lenken von Licht, das von der Formation in die optische Sonde eintritt, zu einem Detektor; und
  - Analysieren des an dem Detektor empfangenen Lichts.
15. Verfahren nach Anspruch 14, umfassend das Verwenden der optischen Sonde, um die Bohrkronen zu drehen, so dass, wenn die Bohrkronen in die Formation bohrt, die optische Sonde in das gebohrte Loch eingesetzt wird.
16. Verfahren nach Anspruch 15, ferner umfassend zumindest teilweise Abziehen der Bohrkronen in dem gebohrten Loch, so dass Fluide aus der Formation in das gebohrte Loch gezogen werden.
17. Verfahren nach Anspruch 16, ferner umfassend Ab-

ziehen der Fluide längs der Bohrkronen zu der optischen Sonde und Analysieren der Fluide unter Verwendung der optischen Sonde.

- 5 18. Verfahren nach Anspruch 14, umfassend Herausziehen der Bohrkronen aus dem Loch und nachfolgendes Einsetzen der optischen Sonde, nachdem das Loch unter Verwendung der Bohrkronen gebohrt wurde.
- 10 19. Verfahren nach Anspruch 14, wenn es unter Verwendung einer wie in einem der Ansprüche 1-13 beanspruchten Vorrichtung ausgeführt wird.

15

### Revendications

1. Appareil pour examiner des formations souterraines entourant un trou de forage, comprenant :
- un outil de forage (28) ;
  - une sonde optique (30) ayant sensiblement le même diamètre externe que l'outil de forage ;
  - un mécanisme d'entraînement (22) pouvant être utilisé pour amener l'outil de forage à forer un trou dans la formation lorsque l'appareil est dans le trou de forage, et pour avancer la sonde optique dans le trou foré ; et
  - un système optique, agencé de sorte que, lorsque la sonde optique est dans le trou foré, la lumière provenant d'une source de lumière (32) soit dirigée dans la sonde optique, la lumière entrant dans la sonde à partir de la source soit dirigée vers la formation autour du trou foré, et la lumière entrant dans la sonde à partir de la formation autour du trou foré soit dirigée vers un détecteur.
2. Appareil selon la revendication 1, dans lequel l'outil de forage et la sonde optique forment une seule unité de sonde allongée.
3. Appareil selon la revendication 2, dans lequel l'outil de forage est monté sur l'extrémité de la sonde optique.
4. Appareil selon la revendication 3, dans lequel le système optique comprend un miroir (48) conique situé au niveau de la jonction entre l'outil de forage et la sonde optique.
5. Appareil selon l'une quelconque des revendications 2 à 4, dans lequel le mécanisme d'entraînement agit sur la sonde optique pour amener l'outil de forage à forer le trou.
6. Appareil selon l'une quelconque des revendications 2 à 5, dans lequel l'outil de forage est pourvu d'un

- passage de liquide pour diriger tout fluide de formation réentrant dans le trou foré le long de l'unité de sonde.
7. Appareil selon la revendication 6, dans lequel le trajet de liquide conduit à un piège capillaire dans l'unité de sonde où le fluide peut être analysé. 5
8. Appareil selon la revendication 1, dans lequel l'outil de forage et la sonde optique sont deux unités discrètes. 10
9. Appareil selon la revendication 8, dans lequel le système optique comprend un miroir (48) conique situé dans la sonde optique. 15
10. Appareil selon la revendication 8 ou 9, dans lequel le mécanisme d'entraînement comprend des moyens pour aligner l'outil de forage ou la sonde optique avec la position du trou foré. 20
11. Appareil selon l'une quelconque des revendications précédentes, comprenant en outre un corps d'outil dans lequel sont situés le mécanisme d'entraînement, une source de lumière et un détecteur et au moins une partie du système optique. 25
12. Appareil selon la revendication 11, dans lequel le corps comprend également des bras (14) qui peuvent être mis en oeuvre pour s'appuyer contre la paroi du trou de forage de manière à pousser le corps d'outil contre la partie de la paroi du trou de forage dans laquelle le trou doit être foré. 30
13. Appareil selon l'une quelconque des revendications précédentes, dans lequel la sonde optique comprend en outre un alésage à travers lequel des fluides peuvent être retirés du trou foré ou pompés dans celui-ci. 35
14. Procédé d'examen de formations souterraines entourant un trou de forage, comprenant : 40
- le forage d'un trou dans la formation à examiner en utilisant un outil de forage (28) ; 45
  - l'insertion d'une sonde optique (30) ayant sensiblement le même diamètre externe que l'outil de forage dans le trou ;
  - le fait de diriger la lumière provenant d'une source de lumière vers la sonde ; 50
  - le fait de diriger la lumière entrant dans la sonde optique vers la formation autour du trou foré ;
  - le fait de diriger la lumière entrant dans la sonde optique à partir de la formation vers un détecteur ; et 55
  - l'analyse de la lumière reçue dans le détecteur.
15. Procédé selon la revendication 14, comprenant l'utilisation de la sonde optique pour faire tourner l'outil de forage de sorte que, alors que l'outil de forage fore dans la formation, la sonde optique soit insérée dans le trou foré.
16. Procédé selon la revendication 15, comprenant en outre le retrait au moins partiellement de l'outil de forage dans le trou foré de manière à retirer les fluides de la formation dans le trou foré.
17. Procédé selon la revendication 16, comprenant en outre le retrait des fluides le long de l'outil de forage vers la sonde optique et l'analyse des fluides en utilisant la sonde optique.
18. Procédé selon la revendication 14, comprenant, après le forage du trou en utilisant l'outil de forage, le retrait de l'outil de forage du trou et d'insertion ensuite de la sonde optique.
19. Procédé selon la revendication 14, lorsqu'il est effectué en utilisant un appareil selon l'une quelconque des revendications 1 à 13.

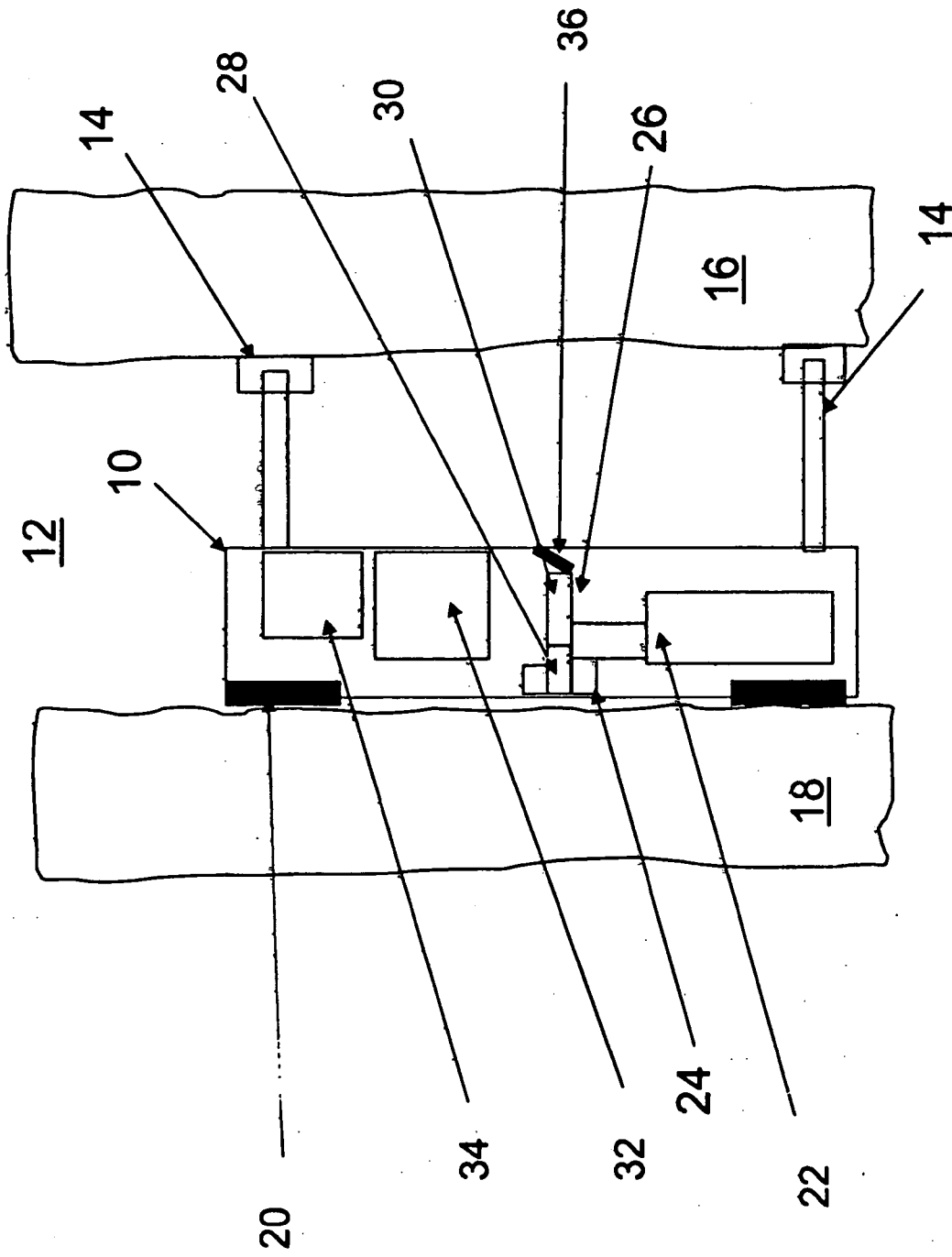

FIGURE 1

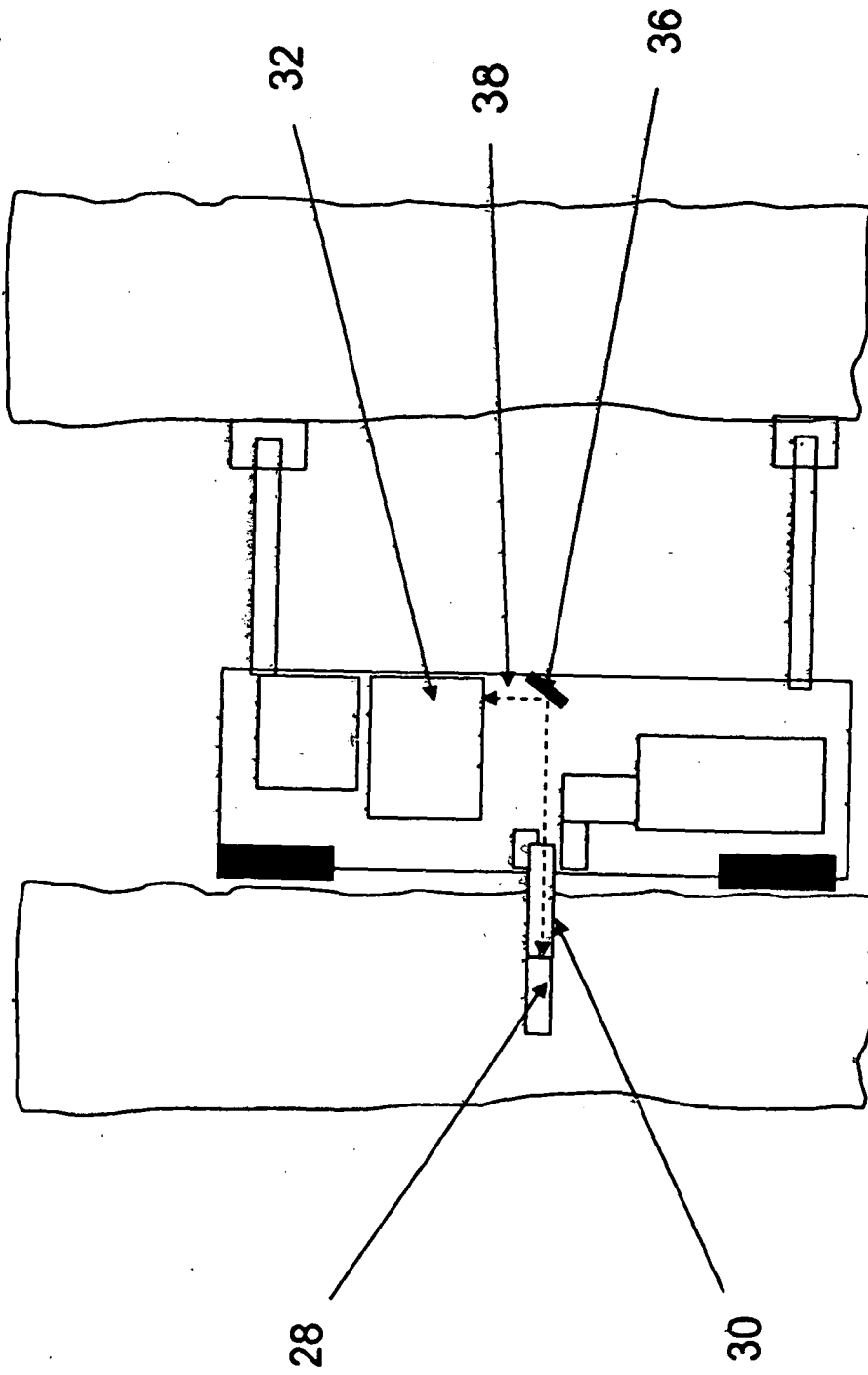

FIGURE 2

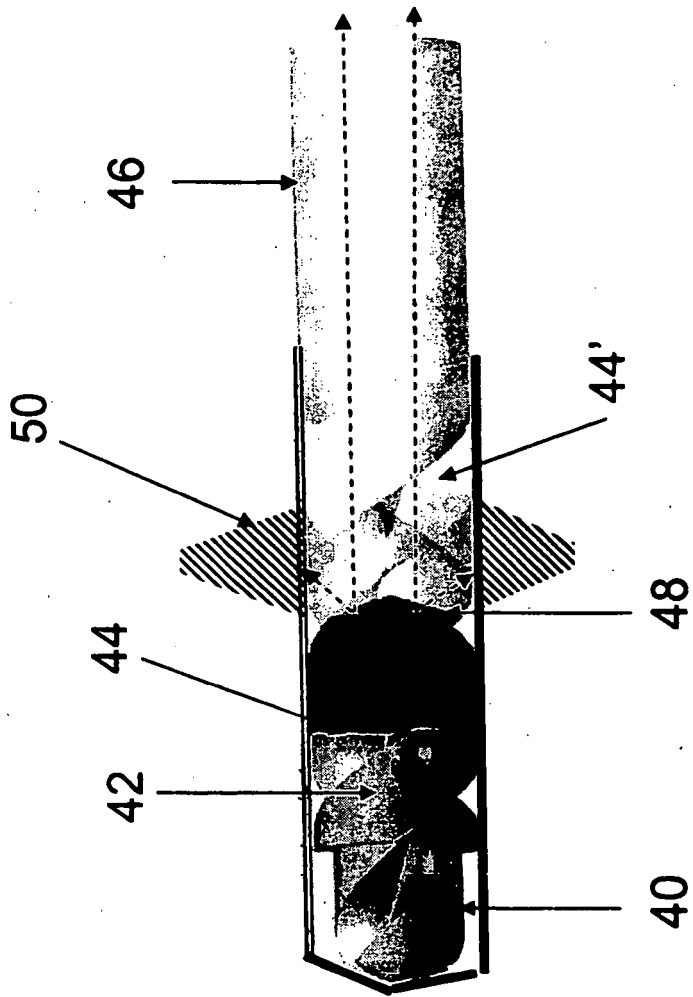

FIGURE 3

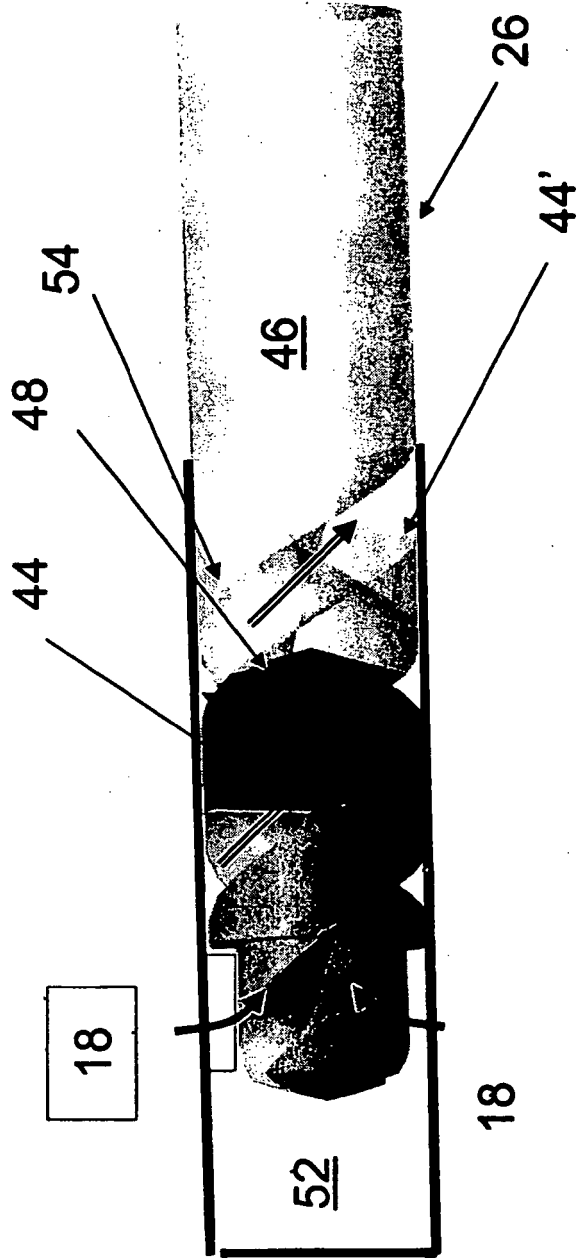

FIGURE 4

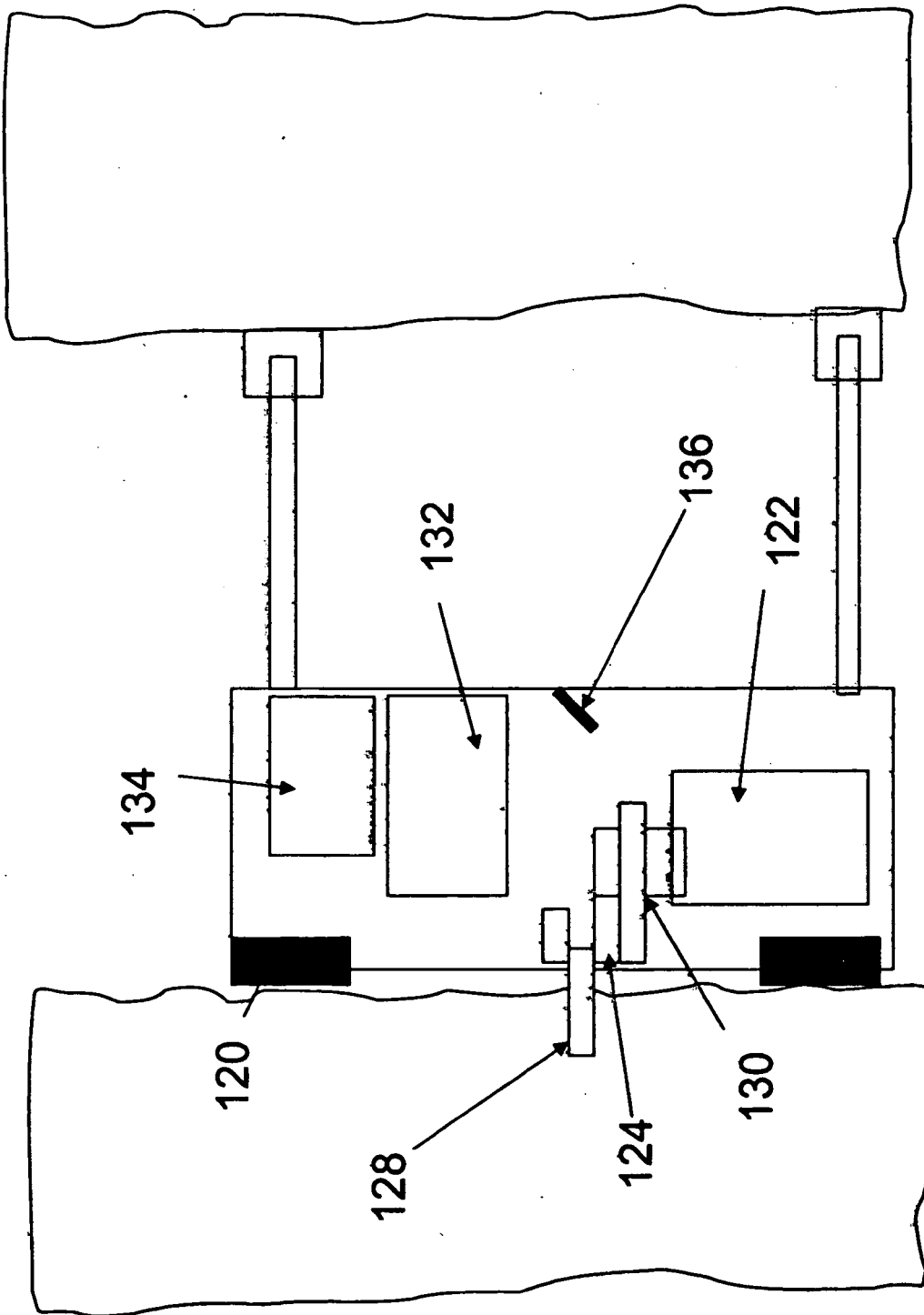

FIGURE 5

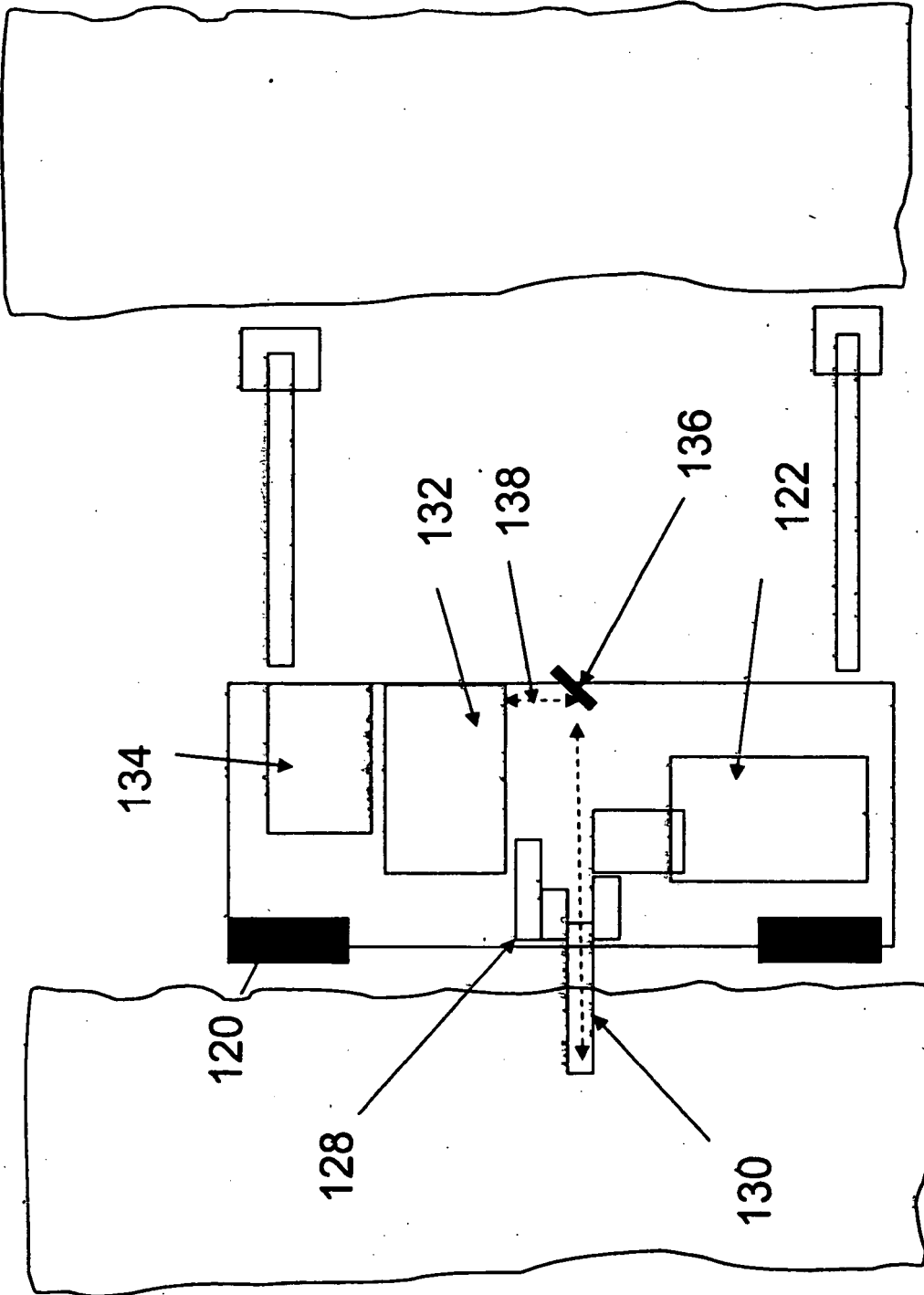

FIGURE 6

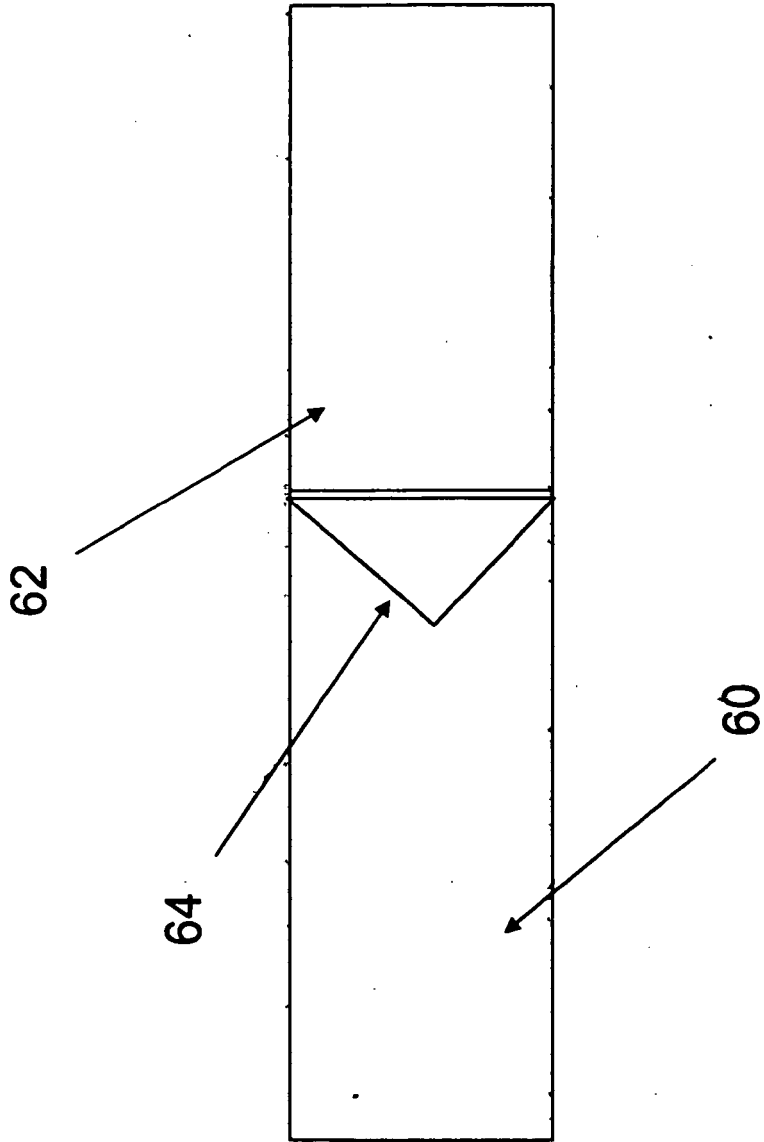

FIGURE 7