



(11) **EP 1 892 728 A1**

(12) **EUROPEAN PATENT APPLICATION**

(43) Date of publication:
27.02.2008 Bulletin 2008/09

(51) Int Cl.:
G21G 4/08^(2006.01)

(21) Application number: **06119491.6**

(22) Date of filing: **24.08.2006**

(84) Designated Contracting States:
AT BE BG CH CY CZ DE DK EE ES FI FR GB GR HU IE IS IT LI LT LU LV MC NL PL PT RO SE SI SK TR
Designated Extension States:
AL BA HR MK YU

- **Tsai, Ying-Ming**
c/o Atomic En. Council-Inst. of Nucl. Energy Lungtan, Taoyuan 333 (TW)
- **Huang, Sun-Rong**
325, Longtan Township, Taoyuan County (TW)
- **Lu, Chien-Hsin**
325, Longtan Township, Taoyuan County (TW)
- **Chang, Mao-Hsung**
303, Hukou Township, Hsinchu County (TW)
- **Chen, Jenn-Tzong**
115, Taipei City (TW)

(71) Applicant: **Atomic Energy Council - Institute of Nuclear Energy Research**
Lungtan, Taoyuan,
Taiwan (TW)

(74) Representative: **Beck, Michael Rudolf et al**
Beck & Rössig
Cuvilliesstrasse 14
81679 München (DE)

- (72) Inventors:
- **Lin, Wu-Jyh**
325, Longtan Township, Taoyuan County (TW)
 - **Duh, Ting-Shien**
325, Longtan Township, Taoyuan County (TW)

(54) **Process of producing the radioisotope TL-201**

(57) The radioisotope T1-201 is produced. The process includes electroplating, irradiating, dissolving, precipitating, ion exchanging, decaying and filtering. The T1-201 obtained is a liquid having a high purity.

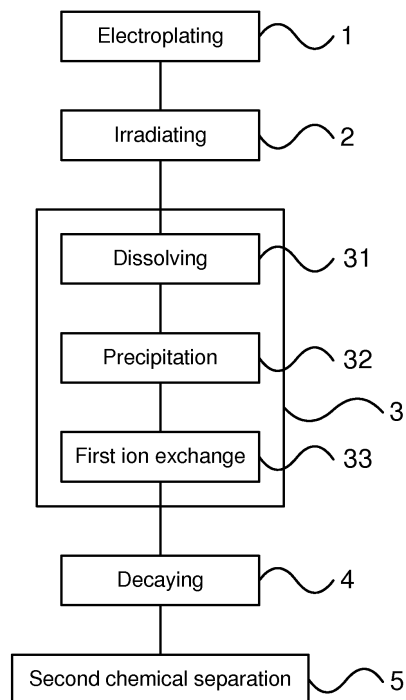

FIG.1

EP 1 892 728 A1

Description**Field of the invention**

[0001] The present invention relates to producing T1-201; more particularly, it relates to quickly filtering out a high-purity T1-201 liquid.

Description of the Related Art

[0002] T1-201 thallos chloride ($^{201}\text{TlCl}_2$) can be absorbed by heart muscle to be gathered at the heart muscle. Therefore, T1-201 can be used in a myocardial image for diagnosing heart disease; and can be applied in other medical diagnoses, like a tumor image. Hence, T1-201 is the most commonly used radioisotope in division of nuclear medicine.

[0003] To produce a T1-201, as revealed in "Production of T1-201 and Pb203 via Proton Induced Nuclear Reaction on Natural Thallium," by Qaim S. M., Weinreich R. and Ollig H., International Journal of Applied Radiation and Isotopes, 30 (1979) pp.85-95, T1-201 is directly washed out. But the T1-201 directly washed out quite often contains impurities so that its purity is not good. Hence, the prior art does not fulfill users' requests on actual use.

Summary of the invention

[0004] The main purpose of the present invention is to form a T1-203 solid target material through electroplating, irradiate the T1-203 solid target material with a proton beam, dissolve the T1-203 solid target material to process through a first chemical separation and a second chemical separation, and quickly filter out a high-purity T1-201 liquid.

[0005] To achieve the above purpose, the present invention is a radioisotope T1-201 production process, where a T1-203 solid target material is obtained from a plated target material of T1-203 through electroplating; the T1-203 solid target material is irradiated with a proton beam by using a cyclotron; the T1-203 solid target material is dissolved with a strong acid liquid to obtain a Pb-201 solution and a T1-203 solution; ammonia and water are added for a precipitation to separate a T1-201 liquid and a Pb-201 liquid out; hydrochloric acid is added for a first ion exchange with a resin while impurities are filtered out; the Pb-201 liquid is taken out to be decayed into a T1-201 liquid; and a hydrochloric acid (HC1) having sulfur dioxide (SO_2) is added to the T1-201 liquid to obtain a T1-201 liquid having a high purity through a second ion exchange by using a resin. Accordingly, a novel radioisotope T1-201 production process is obtained.

Brief description of the drawing

[0006] The present invention will be better understood from the following detailed description of the preferred

embodiment according to the present invention, taken in conjunction with the accompanying drawings, in which

FIG.1 is the plot view showing the process flow of the preferred embodiment according to the present invention; and

FIG.2 is the detailed view showing the flow chart of the preferred embodiment.

10 Description of a preferred embodiment

[0007] The following description of the preferred embodiment is provided to understand the features and the structures of the present invention.

[0008] FIG. 1 is a plot view showing a process flow of a preferred embodiment according to the present invention. As shown in the figure, the present invention is a radioisotope T1-201 production process, comprising electroplating 1, irradiating 2, processing a first chemical separation 3, decaying 4 and processing a second chemical separation 5, where the first chemical separation 3 comprises dissolving 31, processing a precipitation 32 and processing a first ion exchange 33; and the second chemical separation 5 is a second ion exchange. Thus, a novel radioisotope T1-201 production process is obtained for acquiring a T1-201 liquid having a high purity.

[0009] FIG.2 is a detailed view showing a flow chart of the preferred embodiment. As shown in the figure, when producing a radioisotope T1-201 according to the present invention, the following steps are processed:

(a) Electroplating 1: A T1-203 solid target material 12 is obtained from a plated target material 11 of T1-203 through electroplating.

(b) Irradiating 2: The T1-203 solid target material 12 is irradiated with a proton beam by using a cyclotron 21, where an irradiation energy of the cyclotron 21 is located between fifteen mega electron volts (MeV) and forty MeV.

(c) Processing a first chemical separation: The first chemical separation 3 comprises the following steps:

(c1) Dissolving 31: After the irradiating, the T1-203 solid target material 12 is dissolved with a strong acid liquid 34 to obtain a Pb-201 solution 35 and a T1-203 solution 36, where the strong acid liquid 34 is a solution of nitric acid having ferric iron ($\text{HNO}_3/\text{Fe}_3/\text{H}_2\text{O}$).

(c2) Processing a precipitation 32: Ammonia (NH_3) and water 321 are added to the Pb-201 solution 35 and the T1-203 solution 36 for a precipitation to separate out a T1-201 liquid 37 and a Pb-201 liquid 38; and

(c3) Processing a first ion exchange 33: Hydro-

chloric acid (HCl) 331 is added to the TI-201 liquid 37 and the Pb-201 liquid 38 for a first ion exchange by using a resin 332 with impurities filtered out;

(d) Decaying 4: The Pb-201 liquid is taken out to be decayed into a T1-201 liquid 41.

(e) Processing a second chemical separation: And a second chemical separation 5 is processed, which is a second ion exchange 51.

(e1) Processing a second ion exchange 51: An HCl acid having sulfur dioxide (SO₂) 511 is added to the T1-201 liquid 41 to obtain a T1-201 liquid 52 having a high purity through a second ion exchange by using a resin 512.

[0010] Thus, a novel radioisotope T1-201 production process is obtained.

[0011] To sum up, the present invention is a radioisotope T1-201 production process, where a T1-203 solid target material is formed through an electroplating; the T1-203 solid target material is irradiated with a proton beam; the T1-203 solid target material is dissolved to be processed through a first chemical separation and a second chemical separation; and a T1-201 liquid is quickly filtered out, which has a high purity.

[0012] The preferred embodiment herein disclosed is not intended to unnecessarily limit the scope of the invention. Therefore, simple modifications or variations belonging to the equivalent of the scope of the claims and the instructions disclosed herein for a patent are all within the scope of the present invention.

Claims

1. Process of producing the radioisotope TI-201, comprising steps of:

(a) Electroplating: wherein a T1-203 solid target material is obtained from a plated target material of T1-203 through electroplating;

(b) Irradiating: wherein said T1-203 solid target material is irradiated with a proton beam by using a cyclotron;

(c) Processing a first chemical separation: wherein said T1-203 solid target material is dissolved with a strong acid liquid to be separated into a T1-201 liquid and a Pb-201 liquid with impurities filtered out;

(d) Decaying: wherein said Pb-201 liquid is obtained to be decayed into a TI-201 liquid; and

(e) Processing a second chemical separation: wherein a T1-201 liquid having a high purity is obtained through filtering.

2. The process according to claim 1, wherein an irradiation energy of said cyclotron in step (b) is located between 15 mega electron volts (MeV) and 40 MeV.

3. The process according to claim 1, wherein said step (c) comprises steps of:

(c1) Dissolving: wherein, after said irradiating, said T1-203 solid target material is dissolved with a strong acid liquid to obtain a Pb-201 solution and a T1-203 solution;

(c2) Processing a precipitation: wherein ammonia (NH₃) and water are applied to said Pb-201 solution and said T1-203 solution for a precipitation to obtain a T1-201 liquid and a Pb-201 liquid; and

(c3) Processing a first ion exchange: wherein hydrochloric acid (HCl) is applied to said T1-201 liquid and said Pb-201 liquid for an ion exchange by using a resin with impurities filtered out.

4. The process according to claim 3, wherein said strong acid liquid used in step (c1) is a solution of nitric acid having ferric iron (HNO₃/Fe₃/H₂O).

5. The process according to claim 1, wherein step (e) is a second ion exchange; and wherein an HCl having sulfur dioxide (SO₂) is applied to said T1-201 liquid to obtain a T1-201 liquid having a high purity through a second ion exchange by using a resin.

6. Process of producing the radioisotope T1-201, comprising steps of:

(a) Electroplating: wherein a T1-203 solid target material is obtained from a plated target material of T1-203 through electroplating;

(b) Irradiating: wherein said T1-203 solid target material is irradiated with a proton beam by using a cyclotron;

(c1) Dissolving: wherein, after said irradiating, said T1-203 solid target material is dissolved with a strong acid liquid to obtain a Pb-201 solution and a T1-203 solution;

(c2) Processing a precipitation: wherein NH₃ and water are applied to said Pb-201 solution and said T1-203 solution for a precipitation to obtain a T1-201 liquid and a Pb-201 liquid;

(c3) Processing a first ion exchange: wherein HCl is applied to said T1-201 liquid and said Pb-201 liquid for an ion exchange by using a resin with impurities filtered out;

(d) Decaying: wherein said Pb-201 liquid is obtained to be decayed into a TI-201 liquid; and

(e1) Processes a second ion exchange: wherein an HCl having SO₂ is applied to said T1-201 liquid to obtain a T1-201 liquid having a high

purity through an second ion exchange by using a resin.

7. The process according to claim 6, wherein an irradiation energy of said cyclotron in step (b) is located between 15MeV and 40 MeV. 5
8. The process according to claim 6, wherein said strong acid liquid used in step (c1) is HNO₃/Fe₃/H₂O. 10

15

20

25

30

35

40

45

50

55

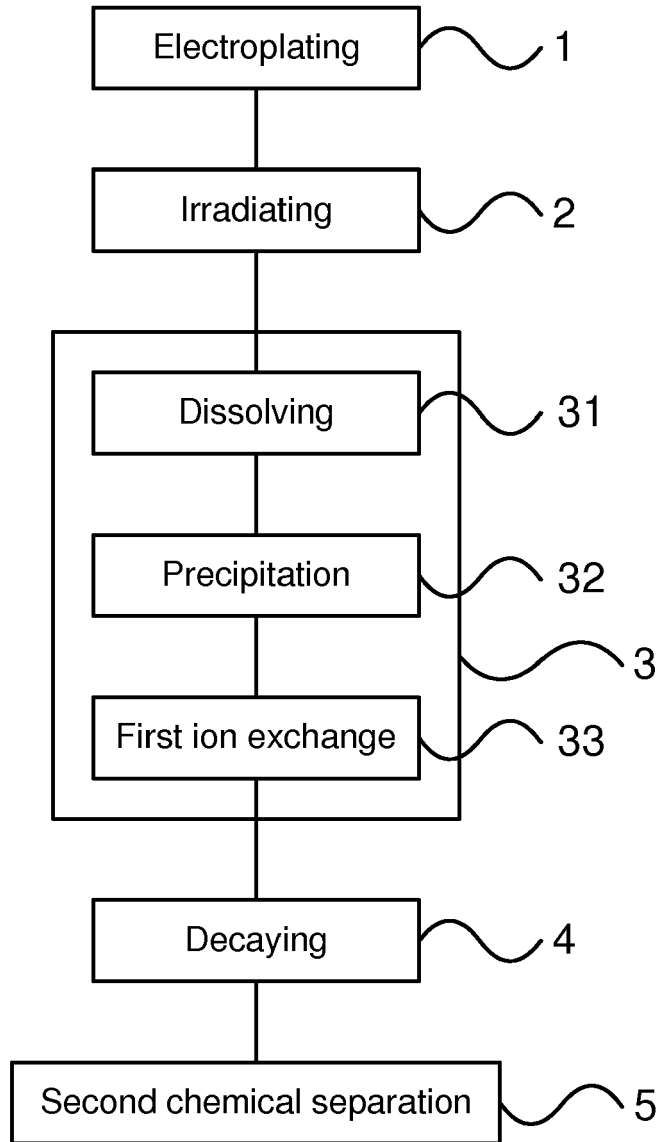

FIG.1

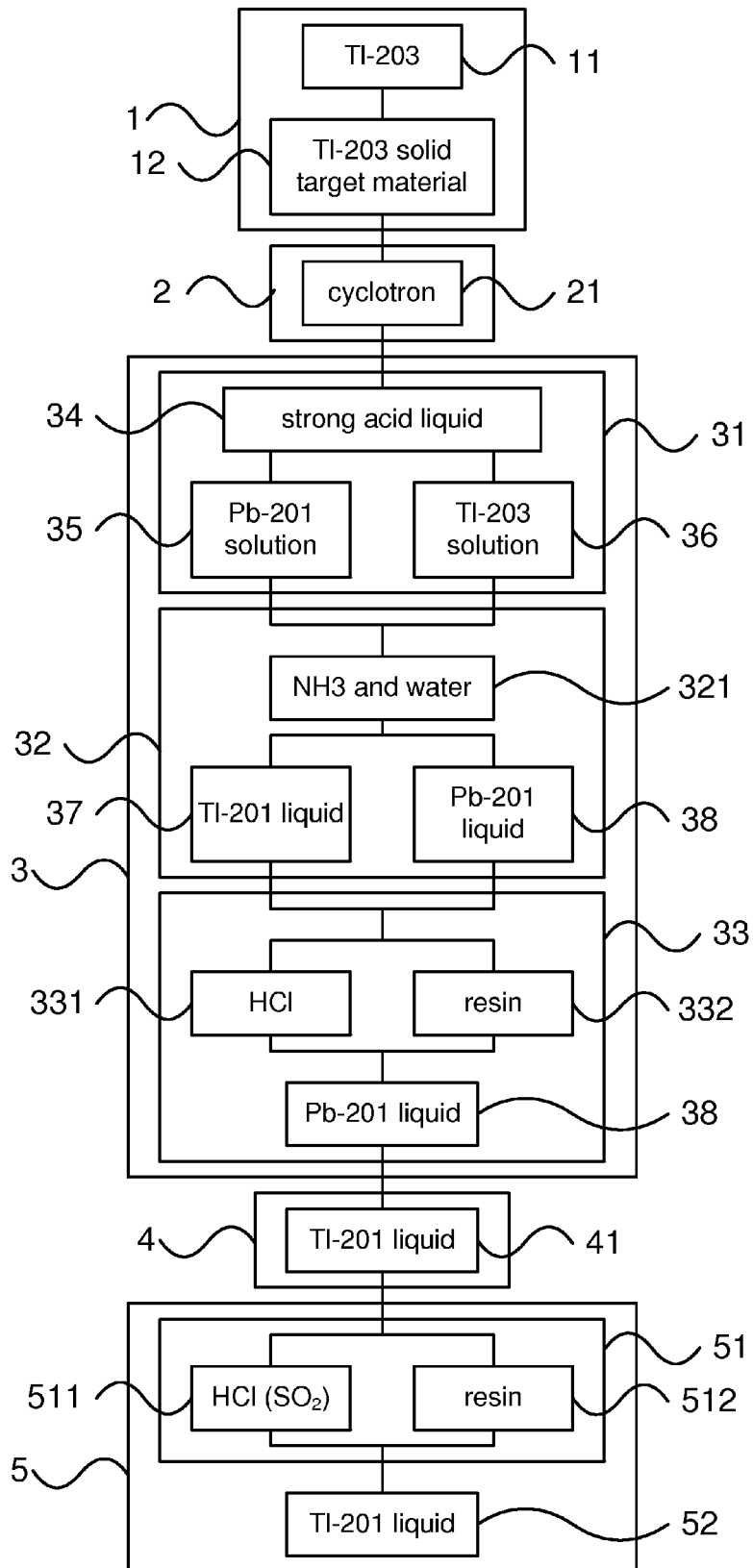

FIG.2



DOCUMENTS CONSIDERED TO BE RELEVANT			
Category	Citation of document with indication, where appropriate, of relevant passages	Relevant to claim	CLASSIFICATION OF THE APPLICATION (IPC)
Y	US 3 993 538 A (LEBOWITZ ELLIOT ET AL) 23 November 1976 (1976-11-23)	1,2	INV. G21G4/08
A	* column 1, line 56 - column 3, line 68 *	6,7	
Y	LAMBRECHT R M ET AL: "TARGET PREPARATION AND RECOVERY OF ENRICHED ISOTOPES FOR MEDICAL RADIONUCLIDE PRODUCTION" NUCLEAR INSTRUMENTS & METHODS IN PHYSICS RESEARCH, SECTION - A: ACCELERATORS, SPECTROMETERS, DETECTORS AND ASSOCIATED EQUIPMENT, ELSEVIER, AMSTERDAM, NL, vol. A282, no. 1, 1 October 1989 (1989-10-01), pages 296-300, XP000067682 ISSN: 0168-9002	1,2	TECHNICAL FIELDS SEARCHED (IPC) G21G
A	* page 297, paragraph 3.1 * * page 298, paragraph 3.5 *	3,6	
A	US 4 297 166 A (KATO MAKOTO ET AL) 27 October 1981 (1981-10-27) * column 1, line 45 - line 59 * * column 2, line 59 - column 3, line 14 *	1,2,6	
D,A	QAIM S M ET AL: "Production of <201>Tl and <203>Pb via proton induced nuclear reactions on natural thallium" INTERNATIONAL JOURNAL OF APPLIED RADIATION AND ISOTOPES UK, vol. 30, no. 2, February 1979 (1979-02), pages 85-95, XP002415296 ISSN: 0020-708X * page 93, left-hand column, paragraph 2 - page 94, left-hand column, paragraph 2 *	4,8	
The present search report has been drawn up for all claims			
Place of search The Hague		Date of completion of the search 18 January 2007	Examiner Capostagno, Eros
CATEGORY OF CITED DOCUMENTS X : particularly relevant if taken alone Y : particularly relevant if combined with another document of the same category A : technological background O : non-written disclosure P : intermediate document		T : theory or principle underlying the invention E : earlier patent document, but published on, or after the filing date D : document cited in the application L : document cited for other reasons & : member of the same patent family, corresponding document	

2
EPO FORM 1503 03.82 (F04C01)

**ANNEX TO THE EUROPEAN SEARCH REPORT
ON EUROPEAN PATENT APPLICATION NO.**

EP 06 11 9491

This annex lists the patent family members relating to the patent documents cited in the above-mentioned European search report. The members are as contained in the European Patent Office EDP file on The European Patent Office is in no way liable for these particulars which are merely given for the purpose of information.

18-01-2007

Patent document cited in search report	Publication date	Patent family member(s)	Publication date
US 3993538 A	23-11-1976	NONE	

US 4297166 A	27-10-1981	CA 1119122 A1	02-03-1982
		DE 2961848 D1	04-03-1982
		EP 0003819 A1	05-09-1979
		JP 54111100 A	31-08-1979

EPO FORM P0459

For more details about this annex : see Official Journal of the European Patent Office, No. 12/82

REFERENCES CITED IN THE DESCRIPTION

This list of references cited by the applicant is for the reader's convenience only. It does not form part of the European patent document. Even though great care has been taken in compiling the references, errors or omissions cannot be excluded and the EPO disclaims all liability in this regard.

Non-patent literature cited in the description

- **QAIM S. M ; WEINREICH R. ; OLLIG H.** Production of Tl-201 and Pb203 via Proton Induced Nuclear Reaction on Natural Thallium. *International Journal of Applied Radiation and Isotopes*, 1979, vol. 30, 85-95
[0003]