



(11) **EP 1 902 787 A3**

(12) **EUROPEAN PATENT APPLICATION**

(88) Date of publication A3:
17.09.2008 Bulletin 2008/38

(51) Int Cl.:
B05C 5/02 (2006.01)

(43) Date of publication A2:
26.03.2008 Bulletin 2008/13

(21) Application number: **07117015.3**

(22) Date of filing: **24.09.2007**

(84) Designated Contracting States:
AT BE BG CH CY CZ DE DK EE ES FI FR GB GR HU IE IS IT LI LT LU LV MC MT NL PL PT RO SE SI SK TR
Designated Extension States:
AL BA HR MK RS

(72) Inventors:
• **Lübbecke, Kai**
21357 Wittorf (DE)
• **Burmester, Thomas**
21354 Bleckede (DE)
• **Kufner, Hubert**
21335 Lüneburg (DE)

(30) Priority: **22.09.2006 DE 202006014743 U**
09.02.2007 DE 202007002156 U

(74) Representative: **Eisenführ, Speiser & Partner**
Patentanwälte Rechtsanwälte
Postfach 10 60 78
28060 Bremen (DE)

(71) Applicant: **NORDSON CORPORATION**
Westlake, Ohio 44145-1119 (US)

(54) **Apparatus for applying fluids such as adhesive, in particular hot melt adhesive**

(57) The invention concerns an apparatus for applying fluids such as adhesive, in particular hot melt adhesive, to a substrate which is movable relative to the apparatus, comprising a main body (12) and an application valve (22) for selectively interrupting or enabling the flow of fluid, wherein the main body (12) can be connected to a fluid source and has a slot-shaped nozzle opening (54) communicating with a distributor passage (14) and a plunger (16) which is arranged movably in the distributor passage (14) and by means of which the length of the distributor passage (14), which can be acted upon with fluid, is variable.

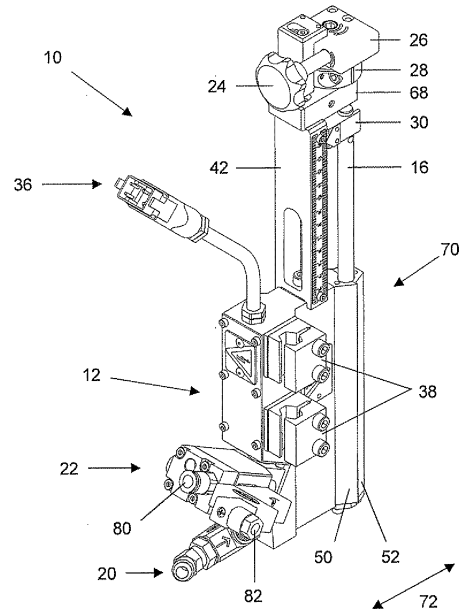

Fig.1

EP 1 902 787 A3



DOCUMENTS CONSIDERED TO BE RELEVANT

Category	Citation of document with indication, where appropriate, of relevant passages	Relevant to claim	CLASSIFICATION OF THE APPLICATION (IPC)
X	DE 41 30 432 A1 (KUESTERS EDUARD MASCHF [DE]) 18 March 1993 (1993-03-18) * column 2, line 50 - column 5, line 9; figures 1-9 *	1-24	INV. B05C5/02
A	US 5 305 955 A (SMITHERMAN JOHN P [US] ET AL) 26 April 1994 (1994-04-26) * column 2, line 36 - column 5, line 23; figures 1-5 *	2-4,11, 14	
A	DE 102 53 410 A1 (BARBERAN LATORRE JESUS FRANCIS [ES]) 22 January 2004 (2004-01-22) * paragraphs [0017] - [0025] *	2-4,12, 14	
A,D	WO 2004/103577 A (NORDSON CORP [US]; BUCHHOLZ HELMUT [DE]) 2 December 2004 (2004-12-02) * page 1, line 20 - page 8, line 30; figures 1-5 *	2-5,11, 12,14	
A,D	WO 00/67914 A (NORDSON CORP [US]; BURMESTER THOMAS [DE]; STEFFENS JOERG [DE]) 16 November 2000 (2000-11-16) * page 5, line 20 - page 6, line 38 *	2-5,11, 12	TECHNICAL FIELDS SEARCHED (IPC) B05C
A,D	DE 203 08 257 U1 (NORDSON CORP [US]) 30 September 2004 (2004-09-30) * paragraphs [0019] - [0024]; figures 1-3,5 *	2-5	
A	DE 101 03 375 C1 (FABER CASTELL AG [DE]) 27 June 2002 (2002-06-27) * paragraph [0017]; figures 1-5 *	5-7	
A	GB 1 503 511 A (DRG PACKAGING LTD) 15 March 1978 (1978-03-15) * page 1, line 55 - page 2, line 6; figures 1,2 *	6,14-17	
----- -/--			

The present search report has been drawn up for all claims

10

EPO FORM 1503 03.02 (P04C01)

Place of search The Hague	Date of completion of the search 13 August 2008	Examiner Menn, Patrick
CATEGORY OF CITED DOCUMENTS X : particularly relevant if taken alone Y : particularly relevant if combined with another document of the same category A : technological background O : non-written disclosure P : intermediate document		T : theory or principle underlying the invention E : earlier patent document, but published on, or after the filing date D : document cited in the application L : document cited for other reasons & : member of the same patent family, corresponding document



DOCUMENTS CONSIDERED TO BE RELEVANT			
Category	Citation of document with indication, where appropriate, of relevant passages	Relevant to claim	CLASSIFICATION OF THE APPLICATION (IPC)
A	EP 1 260 277 A (SCM GROUP SPA [IT]) 27 November 2002 (2002-11-27) * paragraph [0020]; figure 3 * -----	14	
A	US 2006/131344 A1 (BRASS JACK [CA] BRASS JACK [CA] ET AL) 22 June 2006 (2006-06-22) * paragraph [0074]; figures 2,15 * -----	21	
			TECHNICAL FIELDS SEARCHED (IPC)
The present search report has been drawn up for all claims			
Place of search The Hague		Date of completion of the search 13 August 2008	Examiner Menn, Patrick
CATEGORY OF CITED DOCUMENTS X : particularly relevant if taken alone Y : particularly relevant if combined with another document of the same category A : technological background O : non-written disclosure P : intermediate document		T : theory or principle underlying the invention E : earlier patent document, but published on, or after the filing date D : document cited in the application L : document cited for other reasons & : member of the same patent family, corresponding document	

10

EPO FORM 1503 03.82 (POAC001)

ANNEX TO THE EUROPEAN SEARCH REPORT
ON EUROPEAN PATENT APPLICATION NO.

EP 07 11 7015

This annex lists the patent family members relating to the patent documents cited in the above-mentioned European search report. The members are as contained in the European Patent Office EDP file on
The European Patent Office is in no way liable for these particulars which are merely given for the purpose of information.

13-08-2008

Patent document cited in search report	Publication date	Patent family member(s)	Publication date
DE 4130432	A1	18-03-1993	NONE
US 5305955	A	26-04-1994	NONE
DE 10253410	A1	22-01-2004	ES 2211294 A1 01-07-2004
WO 2004103577	A	02-12-2004	AT 345879 T 15-12-2006 DE 20308337 U1 14-08-2003 EP 1501640 A1 02-02-2005 ES 2275221 T3 01-06-2007
WO 0067914	A	16-11-2000	AT 250983 T 15-10-2003 AU 4404600 A 21-11-2000 CA 2368115 A1 16-11-2000 DE 29908150 U1 05-08-1999 EP 1181105 A2 27-02-2002 ES 2204574 T3 01-05-2004 JP 2002543967 T 24-12-2002 US 2002026897 A1 07-03-2002
DE 20308257	U1	30-09-2004	WO 2004103576 A1 02-12-2004
DE 10103375	C1	27-06-2002	NONE
GB 1503511	A	15-03-1978	CA 1051653 A1 03-04-1979 ZA 7502502 A 28-04-1976
EP 1260277	A	27-11-2002	IT B020010315 A1 18-11-2002
US 2006131344	A1	22-06-2006	NONE

EPO FORM P0459

For more details about this annex : see Official Journal of the European Patent Office, No. 12/82