



(11) **EP 1 902 959 B9**

(12) **CORRECTED EUROPEAN PATENT SPECIFICATION**

(15) Correction information:

**Corrected version no 1 (W1 B1)**

**Corrections, see**

**Claims DE 1**

**Claims FR 1**

(51) Int Cl.:

**B65B 19/10** <sup>(2006.01)</sup> **B65B 35/52** <sup>(2006.01)</sup>

**B65B 63/02** <sup>(2006.01)</sup> **B65B 35/40** <sup>(2006.01)</sup>

(48) Corrigendum issued on:

**17.10.2012 Bulletin 2012/42**

(45) Date of publication and mention

of the grant of the patent:

**06.06.2012 Bulletin 2012/23**

(21) Application number: **07116876.9**

(22) Date of filing: **20.09.2007**

(54) **Machine for packing cylindrical articles**

Maschine zum Verpacken zylinderförmiger Artikel

Machine pour emballer des articles cylindriques

(84) Designated Contracting States:

**CH DE GB LI NL PL**

(30) Priority: **20.09.2006 IT BO20060645**

(43) Date of publication of application:

**26.03.2008 Bulletin 2008/13**

(73) Proprietor: **G.D SOCIETÀ PER AZIONI**

**40133 Bologna (IT)**

(72) Inventors:

• **Negrini, Fausto**

**41010 Castelfranco Emilia (IT)**

• **Marchetti, Roberto**  
**40013 Castel Maggiore (IT)**

• **Bertuzzi, Ivanoe**  
**40033 Casalecchio di Reno (IT)**

• **Biondi, Andrea**  
**40133 Bologna (IT)**

(74) Representative: **Jorio, Paolo et al**

**Studio Torta S.p.A.**

**Via Viotti, 9**

**10121 Torino (IT)**

(56) References cited:

**EP-A1- 1 626 003 FR-A- 1 475 759**

**US-A- 3 642 112 US-A- 4 306 648**

**EP 1 902 959 B9**

Note: Within nine months of the publication of the mention of the grant of the European patent in the European Patent Bulletin, any person may give notice to the European Patent Office of opposition to that patent, in accordance with the Implementing Regulations. Notice of opposition shall not be deemed to have been filed until the opposition fee has been paid. (Art. 99(1) European Patent Convention).

## Description

**[0001]** The present invention relates to a machine for packing cylindrical articles, and to a group-forming device for forming groups of cylindrical articles.

**[0002]** The present invention may be used to advantage for packing cigarettes, to which the following description refers purely by way of example.

**[0003]** More specifically, the present invention relates to a machine for packing cylindrical articles in the tobacco industry, and which comprises a group-forming device for forming a group of cylindrical articles. The group-forming device in turn comprises a substantially vertical hopper; a conveying device comprising at least one pocket for housing the group of cylindrical articles; and a transfer device for transferring the cylindrical articles from the hopper to the conveying device. The transfer device comprises a push member for pushing a first and at least a second subgroup of cylindrical articles, crosswise to the feed direction, into the pocket at a first and second insertion station respectively; and the second subgroup is inserted, in use, into the pocket on top of the first subgroup to define the group of cylindrical articles.

**[0004]** Examples of machines of the above type for packing cylindrical articles are described in US3707219.

**[0005]** US5590513 describes a cigarette packing machine comprising a group-forming device for forming a group of cigarettes. The group-forming device in turn comprises a substantially vertical hopper housing a mass of downward-fed cigarettes; and a transfer device for transferring a group of cigarettes from the hopper into a folding spindle. And the folding spindle has movable lateral walls for compressing the group of cigarettes.

**[0006]** FR1475759 discloses cigarettes supplied from a hopper to separate stations, where they are fed into pockets of a conveyer, to form successive layers of cigarettes, by means of a pusher. Each group of cigarettes thus formed is ejected from the conveyer by a pusher and passes to a packaging machine. The number of layers of cigarettes in each group invariably equals the number of stations. The cigarettes may be formed into groups of a different number, and there may be three stations at which the conveyer pockets are filled.

**[0007]** Known cigarette packing machines of the above types have the drawback of being unable to satisfactorily pack substantially triangular groups of cigarettes.

**[0008]** In this connection, it is important to note that, being highly unstable, on account of the relative positions of the cigarettes, triangular groups of cigarettes are relatively difficult to handle. To produce packets of triangular groups of cigarettes, therefore, it is essential that means be provided - which are not, on known machines - to maintain the relative positions of the cigarettes, while at the same time adequately preparing the groups for wrapping (normally in a foil wrapping).

**[0009]** It is an object of the present invention to provide a machine for packing cylindrical articles, and a group-

forming device for forming groups of cylindrical articles, designed to at least partly eliminate the aforementioned drawbacks, and which at the same time are cheap and easy to produce.

5 **[0010]** According to the present invention, there are provided a machine for packing cylindrical articles, and a group-forming device for forming groups of cylindrical articles, as claimed in the accompanying independent Claims or in any one of the Claims depending directly or  
10 indirectly on the independent Claims.

**[0011]** A non-limiting embodiment of the present invention will be described by way of example with reference to the accompanying drawings, in which:

15 Figure 1 shows a schematic front view of a cigarette packing machine in accordance with the present invention;

Figure 2 shows a view in perspective of a packet of cigarettes producible on the Figure 1 machine;

20 Figure 3 shows a schematic top plan view, with parts removed for clarity, of a portion of the Figure 1 machine;

Figure 4 shows a schematic front view of a portion of the Figure 1 machine;

25 Figures 5 and 6 show sections along lines V and VI, respectively, of the Figure 3 portion;

Figure 7 shows a view in perspective of a detail of the Figure 1 machine;

30 Figure 8 shows a view in perspective of an alternative embodiment of the Figure 7 detail;

Figures 9 to 11 show schematics of a portion of the Figure 1 machine at different operating stages;

35 Figures 12 and 13 show top plan views of groups of cigarettes of two further shapes packable on a machine in accordance with the present invention;

Figures 14 and 15 show sections along lines XIV and XV, respectively, of the Figure 3 portion.

40 **[0012]** Number 1 in Figure 1 indicates as a whole a machine for packing cylindrical articles, in particular cigarettes 2, to form a packet 3 of cigarettes 2 (Figure 2). With particular reference to Figures 3 and 4, machine 1 comprises a group-forming device 4 for forming a group 5 of cigarettes 2, and which comprises a substantially vertical hopper 6 for housing and feeding a mass of cigarettes 2 downwards to a transfer station 7, a conveyor 8 for feeding group 5 from station 7 along a path P in a given direction A, and a transfer device 9 for transferring cigarettes 2 from hopper 6 to conveyor 8.

45 **[0013]** Device 9 comprises a number of - in the example shown, two - seats 10 and 11 located at the transfer station, and each for receiving from hopper 6 a respective subgroup 12, 13 of cigarettes 2; each subgroup 12, 13 comprising at least one cigarette 2.

50 **[0014]** At the bottom, hopper 6 comprises a number of channels 14, along each of which a column 15 of single cigarettes 2 travels, in use. Each seat 10, 11 is located beneath at least one channel 14, and contains a respec-

tive number of cigarettes 2 different from the number of cigarettes 2 in the other seat 11, 10. In the embodiment shown, seat 10 is located beneath two channels 14, and houses a subgroup 12 comprising three cigarettes 2; and seat 11 is located beneath four channels 14, and houses a subgroup 13 comprising seven cigarettes 2.

**[0015]** The fact that each seat 10, 11 contains a respective number of cigarettes 2, different from the number of cigarettes 2 in the other seat 11, 10, provides for forming group 5 relatively easily.

**[0016]** Each seat 10, 11 comprises two lateral walls 16, each of which is substantially vertical and has an inner surface 17. And each seat 10, 11 comprises a bottom wall 18 having a substantially horizontal top supporting surface 19 and a substantially horizontal bottom supporting surface 19a connected to each other by a respective substantially vertical surface 19b.

**[0017]** An optional known vibrating member (not shown) is provided at seats 10, 11 to vibrate seats 10, 11 to ensure correct insertion of cigarettes 2 inside seats 10, 11.

**[0018]** Conveyor 8 comprises a belt 10 travelling in direction A and looped about two pulleys (not shown); and at least one pocket 21 fitted integrally to belt 20 to travel along path P in direction A.

**[0019]** With particular reference to Figure 7, pocket 21 comprises two lateral walls 22, each having an inner lateral surface 23; a bottom wall 24 having an inner bottom surface 25; and a top wall 26 having an inner top surface 27. Surfaces 23 are crosswise to the given direction, and slope towards each other so that group 5 assumes a substantially triangular shape inside pocket 21. More specifically, surfaces 23 slope so that the space defined inside pocket 21 by surfaces 23, 25 and 27 tapers downwards.

**[0020]** Pocket 21 comprises a slit 28 crosswise to surfaces 23, substantially parallel to direction A, and defining openings in lateral walls 22 and top wall 26; and a slit 29 crosswise to slit 28 and defining an opening in top wall 26.

**[0021]** With particular reference to Figures 3, 5 and 6, device 4 also comprises a push member 30 for pushing subgroups 12, 13 longitudinally, and crosswise to direction A, through respective insertion channels 31, 32 into pocket 21. Push member 30 comprises two pushers 33 comprising a number of push fingers 33a (some of fingers 33a are shown in Figure 3); and each finger 33a is movable longitudinally, and crosswise to direction A, to push a respective cigarette 2 into pocket 21.

**[0022]** Each channel 31, 32 is located at a respective insertion station 34, 35, and comprises two lateral walls 36, each having an inner surface 37; a bottom wall 38 having an inner bottom surface 39; and a top wall 40 having an inner top surface 41.

**[0023]** Inner top surfaces 41 are designed to exert downward pressure on cigarettes 2 in respective subgroups 12, 13, as subgroups 12, 13 are pushed, in use, towards path P.

**[0024]** Each channel 31, 32 is shaped so that the inner

cavity 42 defined by surfaces 37, 39, 41 tapers towards path P, and the cigarettes 2 in subgroup 12, 13 are therefore brought closer together and/or compacted as they travel along relative insertion channel 31, 32 towards conveyor 8.

**[0025]** Channel 32 has one end 43 facing path P at a higher level than a similar end 44 of channel 31, so that, in use, subgroup 13 is inserted into pocket 21 on top of subgroup 12.

**[0026]** It is important to note that the cross sections, parallel to direction A, of cavities 42 vary. More specifically, the respective cross sections, parallel to direction A, of cavities 42 are substantially T-shaped (Figures 5 and 6) at ends 43 and 44, and are substantially L-shaped (Figures 14 and 15) at the opposite ends to ends 43 and 44. This particular design of cavities 42 provides for positioning cigarettes 2 in each subgroup 12, 13 correctly with respect to one another, as cigarettes 2 are fed from hopper 6 to conveyor 8.

**[0027]** With particular reference to Figures 9 to 11, device 4 also comprises a stabilizing device 45 for keeping subgroup 12 positioned correctly inside pocket 21 as pocket 21 travels, in use, along path P between stations 34 and 35. Device 45 has the same structure and operates in the same way as the stabilizing device described in US3642112, to which full reference is made herein. More specifically, device 45 comprises a retaining member 46, which at least partly engages slit 28 to define the top of a portion 47 of pocket 21 housing subgroup 12. And retaining member 46 has a bottom pressure surface 48 for pressing down on subgroup 12.

**[0028]** Device 45 also comprises actuating members (not shown) for moving retaining member 46, in time with pocket 21, along path P from station 34 to station 35 (Figure 9), and, once pocket 21 reaches station 35 (Figure 10), for returning retaining member 46 to station 34 (Figure 11).

**[0029]** Device 4 preferably comprises a known control unit (not shown) for coordinating push member 30 and the actuating members (not shown), so that retaining member 46 begins disengaging the slit when subgroup 13 is at least partly inserted inside pocket 21.

**[0030]** Operation of machine 1 will now be described briefly, as of the instant in which subgroup 12 is correctly positioned inside seat 10.

**[0031]** At this point, push member 30 pushes subgroup 12 through insertion channel 31 into pocket 21; and subgroup 12 is kept positioned correctly inside pocket 21 by retaining member 46, which moves together with pocket 21 from station 34 to station 35.

**[0032]** When pocket 21 reaches station 35, subgroup 13, formed in the meantime inside seat 11, is pushed through channel 32 into pocket 21 and on top of subgroup 12 to form group 5. As subgroup 13 begins engaging pocket 21, retaining member 46 is withdrawn from station 35 to station 34 to disengage slit 28 and avoid interfering with insertion of subgroup 13.

**[0033]** In the above embodiment, group 5 of cigarettes

2 is substantially triangular with its apex facing downwards.

[0034] In a further embodiment, group 5 is formed with its apex facing upwards. In which case, hopper 6 is equipped with mechanical fingers (not shown) for selectively closing some of channels 14 to form, inside seats 10 and 11, superimposed layers (not shown) of decreasing numbers of cigarettes 2 (i.e. layers in which the top layer comprises a smaller number of cigarettes 2 than the underlying layer). The pocket 21 of this further embodiment is shown in Figure 8.

[0035] Though the above description relates to a packet 3 of ten cigarettes 2, the teachings of the present invention obviously also apply to packets containing a different number of cigarettes 2.

[0036] Purely by way of example, Figures 12 and 13 show respective groups 5' and 5" of cigarettes 2 of two further shapes that can be produced and packed in accordance with the present invention. More specifically, group 5' comprises twenty-one cigarettes 2, and group 5" twenty cigarettes 2.

[0037] The above embodiments may also obviously be modified to form subgroups 12, 13 comprising a different number of layers of cigarettes 2. More specifically, in an embodiment not shown, to form groups 5" of twenty cigarettes 2, each subgroup 12, 13 comprises three layers of cigarettes 2. In which case, subgroup 12 comprises six, and subgroup 13 fourteen, cigarettes 2.

## Claims

1. A machine for packing cylindrical articles of the tobacco industry; the machine comprising a group-forming device (4) for forming a group (5) of cylindrical articles (2); the group-forming device (4) in turn comprising a substantially vertical hopper (6) containing a mass of cylindrical articles (2) fed downwards, in use, to a transfer station (7), a conveyor (8) for feeding the group (5) of cylindrical articles (2) from the transfer station (7) along a path (P) in a given direction (A), and a transfer device (9) located at the transfer station (7) and for transferring the cylindrical articles (2) from the hopper (6) to the conveyor (8); the conveyor (8) comprising at least one pocket (21) for housing the group (5) of cylindrical articles (2); the transfer device (9) comprising at least one push member (30) to push a first and at least a second subgroup (12, 13) of cylindrical articles (2), crosswise to the given direction (A), into the pocket (21) at a first and second insertion station (34, 35) respectively; the second subgroup (13) being inserted into the pocket (21) on top of the first subgroup (12) to define the group (5) of cylindrical articles (2); the transfer device (9) comprising a first insertion channel (31) located at the first insertion station (34) between the hopper (6) and the conveyor (8), and at least a second insertion channel (32) located at

the second insertion station (35) between the hopper (6) and the conveyor (8); the first and the second insertion channel (31, 32) each having a cavity (42) tapering towards the conveyor (8), so that the cylindrical articles (2) in the first and second subgroup (12, 13), respectively, are brought closer together and/or compressed as they travel towards the pocket (21);

the machine (1) being **characterized in that** the pocket (21) comprises first inner lateral surfaces (23) crosswise to the given direction (A) and so shaped that the group (5) of cylindrical articles (2) assumes a substantially triangular shape inside the pocket (21); at least one of the first and second insertion channel (31, 32) has a cavity (42) whose cross sections, parallel to said given direction (A), vary in shape from the hopper (6) to the conveyor (8).

2. A machine as claimed in Claim 1, wherein the first and the second subgroup (12, 13) each comprise at least two superimposed layers of cylindrical articles (2).
3. A machine as claimed in Claim 1 or 2, wherein at least one of the cavities (42) of the first and second insertion channel (31, 32) has at least a substantially L-shaped cross section parallel to the given direction (A).
4. A machine as claimed in any one of Claims 1 to 3, wherein at least one of the cavities (42) of the first and second insertion channel (31, 32) has at least a substantially T-shaped cross section parallel to the given direction (A).
5. A machine as claimed in any one of Claims 1 to 4, wherein the first and second insertion channel (31, 32) each comprise a top inner surface (41) at least partly defining the top of the relative cavity (42).
6. A machine as claimed in Claim 5, wherein at least one top inner surface (41) is designed to exert downward pressure on the cylindrical articles (2) in the respective subgroup (12; 13) as the subgroup (12; 13) is pushed, in use, towards the path (P).
7. A machine as claimed in any one of Claims 1 to 6, and comprising a stabilizing device (45) for keeping the first subgroup (12) positioned correctly inside the pocket (21) as the pocket (21) travels, in use, along the path (P) between the first and second insertion station (34, 35).
8. A machine as claimed in Claim 7, wherein the stabilizing device (45) comprises a retaining member (46) defining the top of a portion (47) of the pocket (21); said portion (47) housing the first subgroup (12).

9. A machine as claimed in Claim 8, wherein the retaining member (46) has a bottom pressure surface (48) for pressing down on the first subgroup (12).
10. A machine as claimed in Claim 8 or 9, wherein the stabilizing device (45) comprises actuating members for moving the retaining member (46), in time with the pocket (21), along the path (P) from the first to the second insertion station (34, 35).
11. A machine as claimed in Claim 10, wherein the actuating members impart a back and forth movement to the retaining member (46), so that, in use, once the pocket (21) reaches the second insertion station (35), the retaining member (46) moves back to the first insertion station (34).
12. A machine as claimed in any one of Claims 9 to 11, wherein the pocket (21) comprises a slit (28) crosswise to the first inner lateral surfaces (23); the retaining member (46) at least partly engaging the slit (28) as the pocket (21) travels along the path (P) between the first and second insertion station (34, 35).
13. A machine as claimed in Claim 12, and comprising a control unit for coordinating the push member (30) and the actuating members, so that the retaining member (46) begins disengaging the slit (28) when the second subgroup (13) is at least partly inserted inside the pocket (21).
14. A machine as claimed in any one of Claims 1 to 13, wherein the first subgroup (12) comprises a number of cylindrical articles (2) which differs from the number of cylindrical articles (2) of the second subgroup (13).
15. A machine as claimed in any one of Claims 1 to 14, wherein the pocket (21) is designed to define a downward-tapering space inside.
16. A group-forming device for forming a group (5) of cylindrical articles (2), as claimed in any one of the foregoing Claims.

#### Patentansprüche

1. Maschine zum Verpacken zylinderförmiger Artikel der Tabakindustrie, wobei die Maschine eine gruppenbildende Vorrichtung (4) zum Bilden einer Gruppe (5) zylinderförmiger Artikel (2) umfasst; wobei die gruppenbildende Vorrichtung wiederum ein im Wesentlichen vertikales Magazin (6) umfasst, das eine Masse zylinderförmiger Artikel (2) umfasst, die in Verwendung nach unten einer Transportstation (7) zugeführt werden, einen Förderer (8) zum Zuführen der Gruppe (5) zylinderförmiger Artikel (2) von der

Transportstation (7) entlang einem Pfad (P) in einer gegebenen Richtung (A), und eine Transportvorrichtung (9), die sich an der Transportstation (7) und zum Transportieren (2) der zylinderförmigen Artikel (2) von dem Magazin (6) zu dem Förderer (8) befindet; wobei der Förderer (8) mindestens eine Tasche (21) zum Beherbergen der Gruppe (5) zylinderförmiger Artikel (2) umfasst; wobei die Transportvorrichtung (9) mindestens ein Druckelement (30) zum Drücken einer ersten und mindestens einer zweiten Untergruppe (12, 13) zylinderförmiger Artikel (2) umfasst, quer zu der gegebenen Richtung (A), in die Tasche (21) jeweils an einer ersten und zweiten Einsatzstation (34, 35); wobei die zweite Untergruppe (13) auf der ersten Untergruppe (12) in die Tasche (21) eingesetzt wird, um die Gruppe (5) zylinderförmiger Artikel (2) zu bestimmen; wobei die Transportvorrichtung (9) einen ersten Einsatzkanal (31) umfasst, der sich an der ersten Einsatzstation (34) zwischen dem Magazin (6) und dem Förderer (8) befindet, und mindestens einen zweiten Einsatzkanal (32), der sich an der zweiten Einsatzstation (35) zwischen dem Magazin (6) und dem Förderer (8) befindet; wobei der erste und der zweite Einsatzkanal (31, 32) jeweils einen Hohlraum (42) aufweisen, der sich zu dem Förderer (8) hin verjüngt, so dass die zylinderförmigen Artikel (2) in der ersten beziehungsweise zweiten Untergruppe (12, 13) näher zusammengebracht und/oder zusammengedrückt werden, wenn sie sich zur Tasche (21) bewegen; wobei die Maschine (1) **dadurch gekennzeichnet ist, dass** die Tasche (21) erste innere Seitenflächen (23) quer zur gegebenen Richtung (A) umfasst und so geformt ist, dass die Gruppe (5) zylinderförmiger Artikel (2) eine im Wesentlichen dreieckige Form im Inneren der Tasche (21) annimmt; wobei mindestens einer der ersten und zweiten Einsatzkanäle (31, 32) einen Hohlraum (42) aufweist, dessen Querschnitte parallel zu der gegebenen Richtung (A) in der Form variieren vom Magazin (6) zum Förderer (8).

2. Maschine nach Anspruch 1, wobei die erste und zweite Untergruppe (12, 13) jeweils mindestens zwei überlagerte Schichten zylinderförmiger Artikel (2) umfassen.
3. Maschinen nach Anspruch 1 oder 2, wobei mindestens einer der Hohlräume (42) des ersten und zweiten Einsatzkanals (31, 32) mindestens einen im Wesentlichen L-förmigen Querschnitt parallel zur gegebenen Richtung (A) aufweist.
4. Maschine nach einem der Ansprüche 1 bis 3, wobei mindestens einer der Hohlräume (42) des ersten und zweiten Einsatzkanals (31, 32) mindestens einen im Wesentlichen T-förmigen Querschnitt parallel zur gegebenen Richtung (A) aufweist.

5. Maschine nach einem der Ansprüche 1 bis 4, wobei der erste und zweite Einsatzkanal (31, 32) jeweils eine obere Innenfläche (41) umfasst, die mindestens teilweise den oberen Teil des jeweiligen Hohlraums (42) bestimmt.
6. Maschine nach Anspruch 5, wobei mindestens eine obere Innenfläche (41) ausgestaltet ist, einen nach unten gerichteten Druck auf die zylinderförmigen Artikel (2) in der jeweiligen Untergruppe (12; 13) auszuüben, wenn die Untergruppe (12; 13) in Verwendung zu dem Pfad (P) hin gedrückt wird
7. Maschine nach einem der Ansprüche 1 bis 6, und umfassend eine Stabilisierungsvorrichtung (45), um die erste Untergruppe (12) korrekt im Inneren der Tasche (21) positioniert zu halten, wenn sich die Tasche (21) in Verwendung entlang dem Pfad (P) zwischen der ersten und zweiten Einsatzstation (34, 35) bewegt.
8. Maschine nach Anspruch 7, wobei die Stabilisierungsvorrichtung (45) ein Halteelement (46) umfasst, das den oberen Teil eines Abschnitts (47) der Tasche (21) bestimmt; wobei der Abschnitt (47) die erste Untergruppe (12) beherbergt.
9. Maschine nach Anspruch 8, wobei das Halteelement (46) eine untere Druckfläche (48) zum Hinunterdrücken der ersten Untergruppe (12) aufweist.
10. Maschine nach Anspruch 8 oder 9, wobei die Stabilisierungsvorrichtung (45) Betätigungselemente zum zeitgleichen Bewegen des Halteelements (46) mit der Tasche (21) entlang dem Pfad (P) von der ersten zur zweiten Einsatzstation (34, 35) umfasst.
11. Maschine nach Anspruch 10, wobei die Betätigungselemente dem Halteelement (46) eine Vorwärts- und Rückwärtsbewegung verleihen, so dass in Verwendung, nachdem die Tasche (21) die zweite Einsatzstation (35) erreicht hat, sich das Halteelement (46) zurück zur ersten Einsatzstation (34) bewegt.
12. Maschine nach einem der Ansprüche 9 bis 11, wobei die Tasche (21) einen Schlitz (28) quer zu den ersten inneren Seitenflächen umfasst; wobei das Halteelement (46) zumindest teilweise in den Schlitz (28) eingreift, wenn sich die Tasche (21) entlang dem Pfad (P) zwischen der ersten und zweiten Einsatzstation (34, 35) bewegt.
13. Maschine nach Anspruch 12, und umfassend eine Steuereinheit zum Koordinieren des Druckelements (30) und der Betätigungselemente, so dass das Halteelement (46) beginnt, den Eingriff mit dem Schlitz (28) zu lösen, wenn die zweite Untergruppe (13) zumindest teilweise in das Innere der Tasche (21) ein-

gesetzt ist.

14. Maschine nach einem der Ansprüche 1 bis 13, wobei die erste Untergruppe (12) eine Anzahl zylinderförmiger Artikel (2) umfasst, die sich von der Anzahl zylinderförmiger Artikel (2) der zweiten Untergruppe (13) unterscheidet.
15. Maschine nach einem der Ansprüche 1 bis 14, wobei die Tasche (21) ausgestaltet ist, einen sich nach unten verjüngenden Raum im Inneren zu bestimmen.
16. Gruppenbildende Vorrichtung zum Bilden einer Gruppe (5) zylinderförmiger Artikel (2) nach einem der vorhergehenden Ansprüche.

### Revendications

1. Machine pour emballer des articles cylindriques de l'industrie du tabac ; la machine comprenant un dispositif de formation de groupe (4) permettant de former un groupe (5) d'articles cylindriques (2) ; le dispositif de formation de groupe (4) comprenant lui-même une trémie sensiblement verticale (6) contenant une masse d'articles cylindriques (2) alimentés vers le bas, en utilisation, à une station de transfert (7), un transporteur (8) permettant d'alimenter le groupe (5) d'articles cylindriques (2) en provenance de la station de transfert (7) le long d'un trajet (P) dans une direction donnée (A), et un dispositif de transfert (9) situé au niveau de la station de transfert (7) et pour transférer les articles cylindriques (2) en provenance de la trémie (6) vers le transporteur (8) ; le transporteur (8) comprenant au moins une poche (21) permettant de loger le groupe (5) d'articles cylindriques (2) ; le dispositif de transfert (9) comprenant au moins un organe de poussée (30) permettant de pousser un premier et au moins un second sous-groupe (12, 13) d'articles cylindriques (2), en travers de la direction donnée (A), dans la poche (21) au niveau de première et seconde stations d'insertion (34, 35) respectivement ; le second sous-groupe (13) étant inséré dans la poche (21) au-dessus du premier sous-groupe (12) afin de définir le groupe (5) d'articles cylindriques (2) ; le dispositif de transfert (9) comprenant un premier canal d'insertion (31) situé au niveau de la première station d'insertion (34) entre la trémie (6) et le transporteur (8), et au moins un second canal d'insertion (32) situé au niveau de la seconde station d'insertion (35) entre la trémie (6) et le transporteur (8) ; les premier et second canaux d'insertion (31, 32) comportant chacun une cavité (42) s'affinant en direction du transporteur (8), de sorte que les articles cylindriques (2) dans les premier et second sous-groupes (12, 13), respectivement, sont rapprochés les uns des autres et/ou comprimés pendant leur trajet en direction de la poche

- (21) ;  
la machine (1) étant **caractérisée en ce que** la poche (21) comprend des premières surfaces latérales internes (23) en travers de la direction donnée (A) et formées de façon à ce que le groupe (5) d'articles cylindriques (2) prend une forme sensiblement triangulaire à l'intérieur de la poche (21) ;  
au moins un des premier et second canaux d'insertion (31, 32) comporte une cavité (42) dont les sections parallèles à ladite direction données (A) ont des formes qui varient de la trémie (6) vers le convoyeur (8).
2. Machine selon la revendication 1, dans laquelle le premier et le second sous-groupe (12, 13) comprennent chacun au moins deux couches superposées d'articles cylindriques (2).
  3. Machine selon la revendication 1 ou 2, dans laquelle au moins une des cavités (42) des premier et second canaux d'insertion (31, 32) comporte au moins une section sensiblement en forme de L parallèle à la direction donnée (A).
  4. Machine selon l'une quelconque des revendications 1 à 3, dans laquelle au moins une des cavités (42) des premier et second canaux d'insertion (31, 32) comporte au moins une section sensiblement en forme de T parallèle à la direction données (A).
  5. Machine selon l'une quelconque des revendications 1 à 4, dans laquelle les premier et second canaux d'insertion (31, 32) comprennent chacun une surface interne supérieure (41) définissant au moins partiellement le dessus de la cavité (42) correspondante.
  6. Machine selon la revendication 5, dans laquelle au moins une surface interne supérieure (41) est conçue pour exercer une pression vers le bas sur les articles cylindriques (2) dans le sous-groupe (12, 13) respectif pendant que le sous-groupe (12, 13) est poussé, en utilisation, vers le trajet (P).
  7. Machine selon l'une quelconque des revendications 1 à 6, et comprenant un dispositif de stabilisation (45) permettant de maintenir le premier sous-groupe (12) dans une position correcte à l'intérieur de la poche (21) pendant que la poche (21) se déplace, en utilisation, le long du trajet (P) entre les première et seconde stations d'insertion (34, 35).
  8. Machine selon la revendication 7, dans laquelle le dispositif de stabilisation (45) comprend un organe de retenue (46) définissant le dessus d'une portion (47) de la poche (21) ; ladite portion (47) logeant le premier sous-groupe (12).
  9. Machine selon la revendication 8, dans laquelle l'organe de retenue (46) comporte une surface de pression inférieure (48) permettant d'appliquer une pression vers le bas au premier sous-groupe (12).
  10. Machine selon la revendication 8 ou 9, dans laquelle le dispositif de stabilisation (45) comprend des organes d'actionnement permettant de déplacer l'organe de retenue (46), en même temps que la poche (21), le long du trajet (P) de la première à la seconde station d'insertion (34, 35).
  11. Machine selon la revendication 10, dans laquelle les organes d'actionnement transmettent un mouvement d'avant en arrière à l'organe de retenue (46) de sorte que, en utilisation, une fois que la poche (21) atteint la seconde station d'insertion (35), l'organe de retenue (46) retourne à la première station d'insertion (34).
  12. Machine selon l'une quelconque des revendications 9 à 11, dans laquelle la poche (21) comprend une fente (28) en travers des premières surfaces latérales internes (23) ; l'organe de retenue (46) se logeant au moins partiellement dans la fente (28) alors que la poche (21) se déplace le long du trajet (P) entre les première et seconde stations d'insertion (34, 35).
  13. Machine selon la revendication 12, et comprenant une unité de commande permettant de coordonner l'organe de poussée (30) et les organes d'actionnement, de sorte que l'organe de retenue (46) commence à se retirer de la fente (28) lorsque le second sous-groupe (13) est au moins partiellement inséré à l'intérieur de la poche (21).
  14. Machine selon l'une quelconque des revendications 1 à 13, dans laquelle le premier sous-groupe (12) comprend un nombre d'articles cylindriques (2) différent du nombre d'articles cylindriques (2) du second sous-groupe (13).
  15. Machine selon l'une quelconque des revendications 1 à 14, dans laquelle la poche (21) est conçue pour définir en son intérieur un espace s'affinant vers le bas.
  16. Dispositif de formation de groupe permettant de former un groupe (5) d'articles cylindriques (2), tel que revendiqué dans l'une quelconque des revendications précédentes.

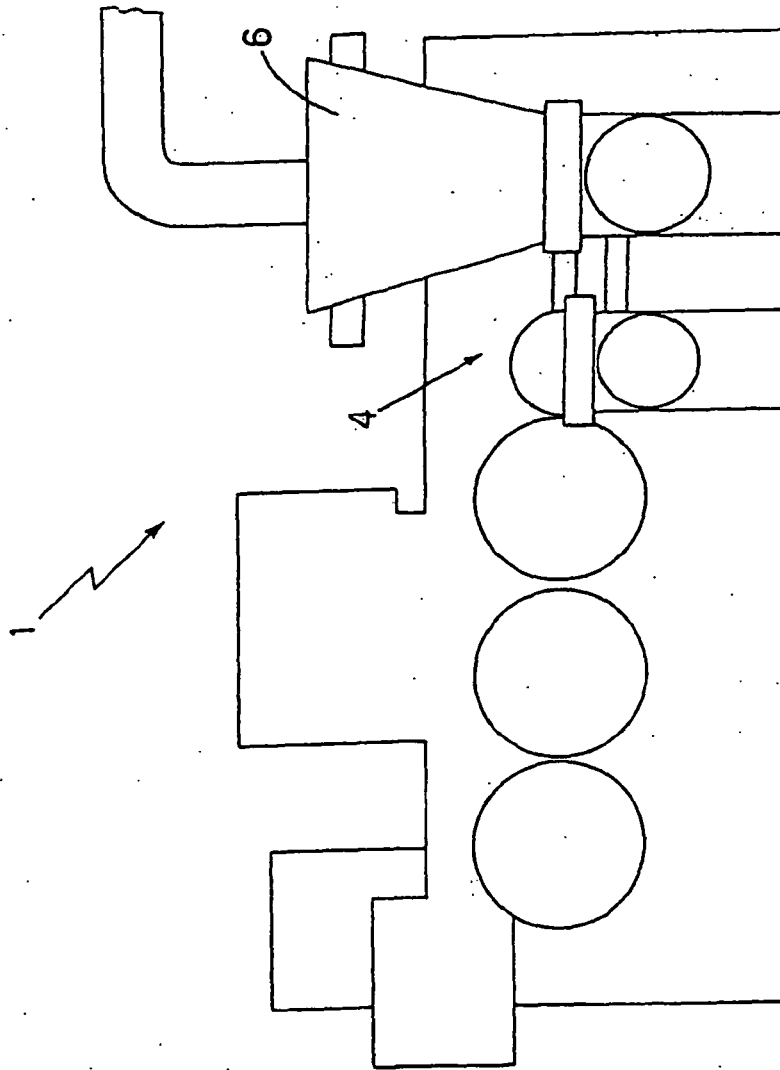

Fig.1

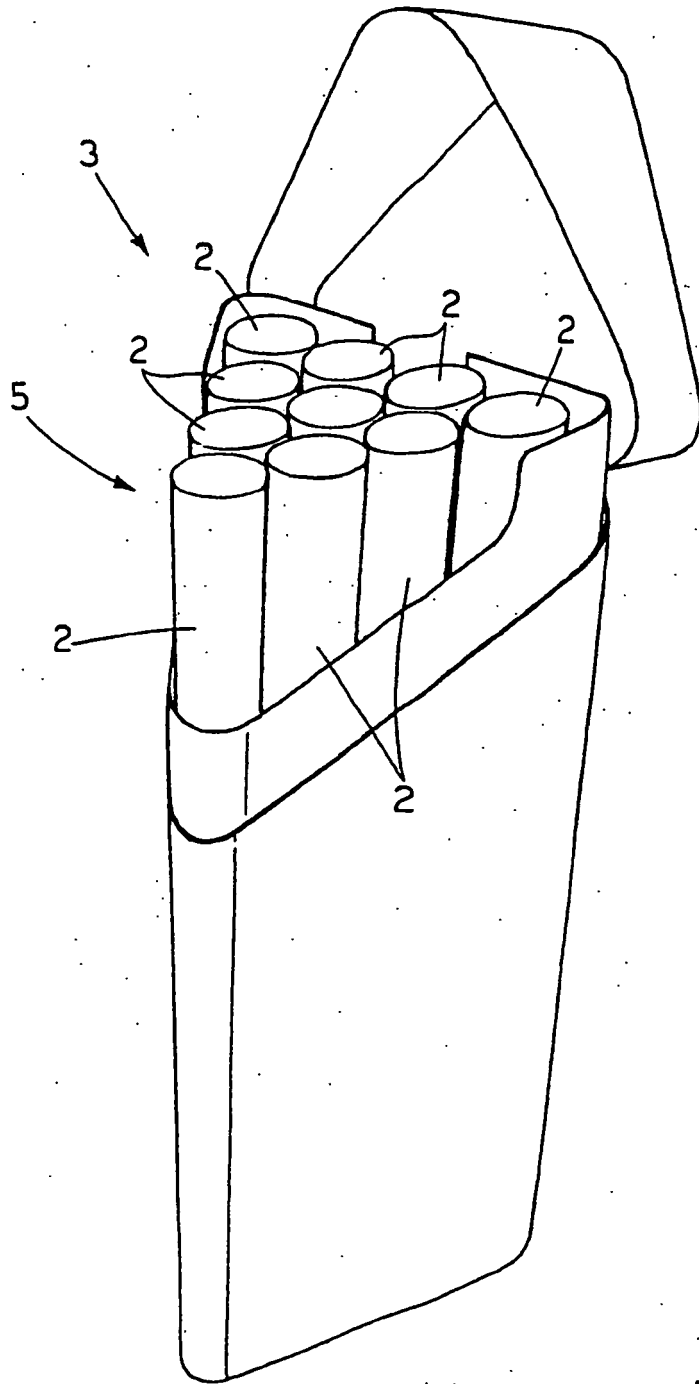
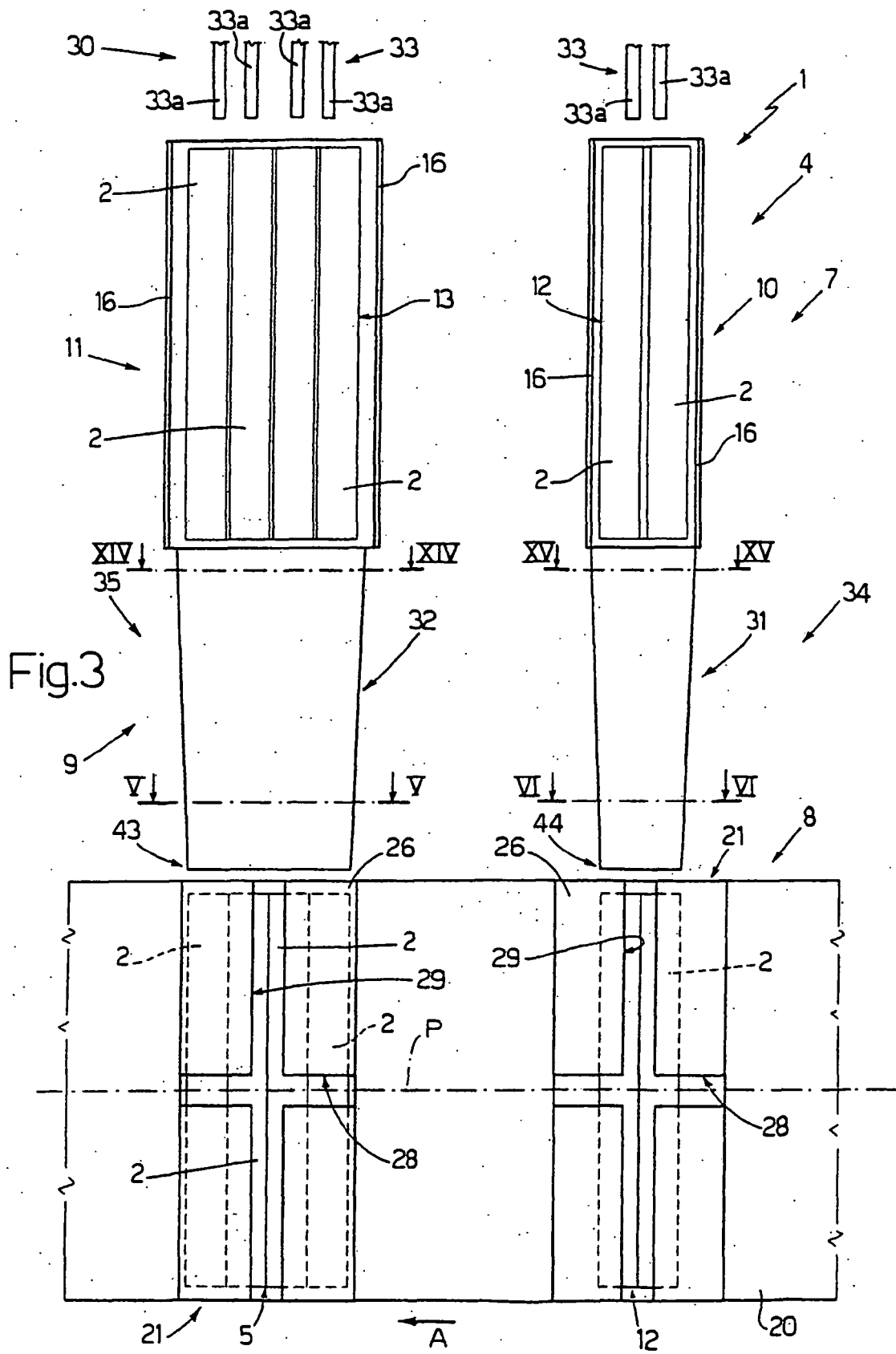

Fig.2



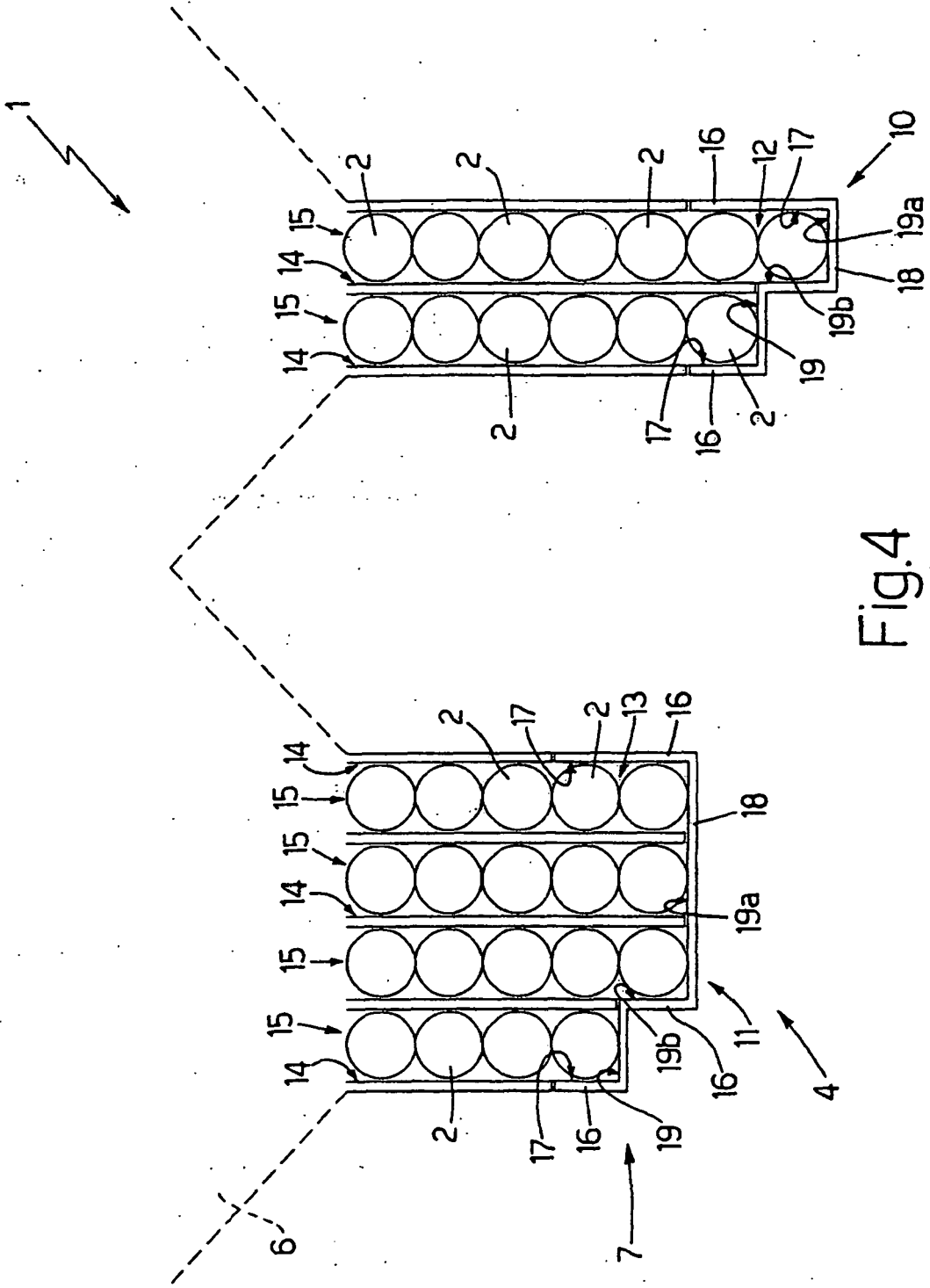

FIG. 4

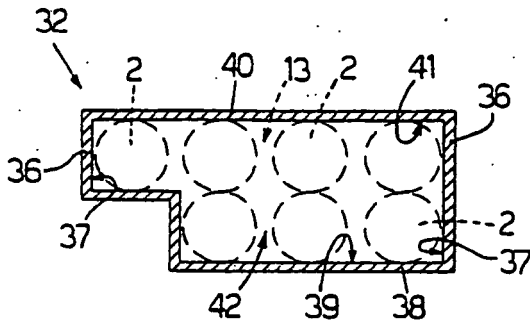

Fig.14

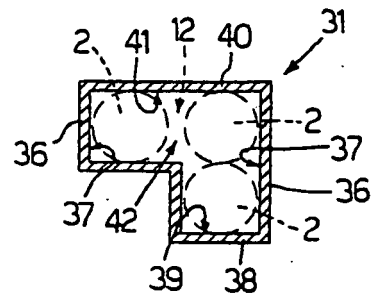

Fig.15

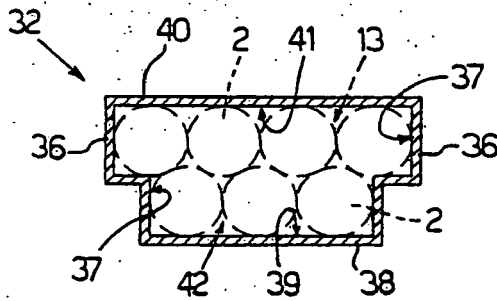

Fig.5

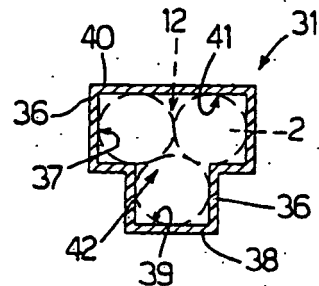

Fig.6

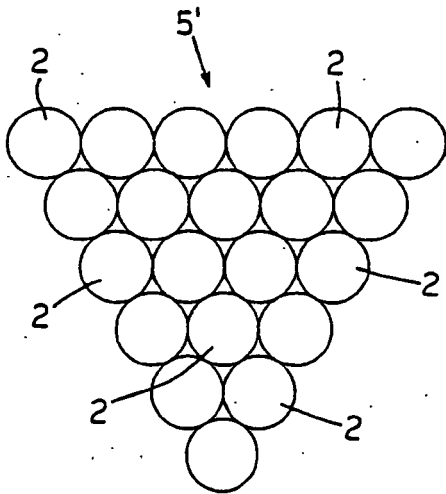

Fig.12

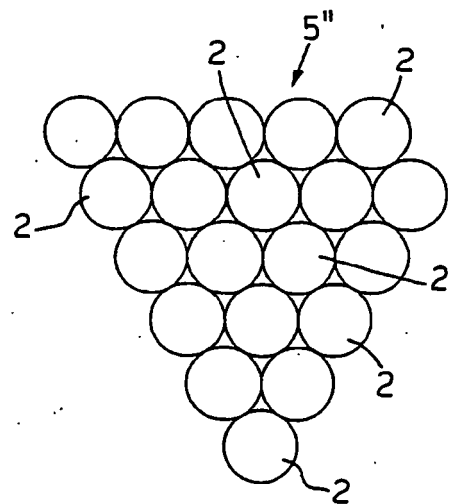
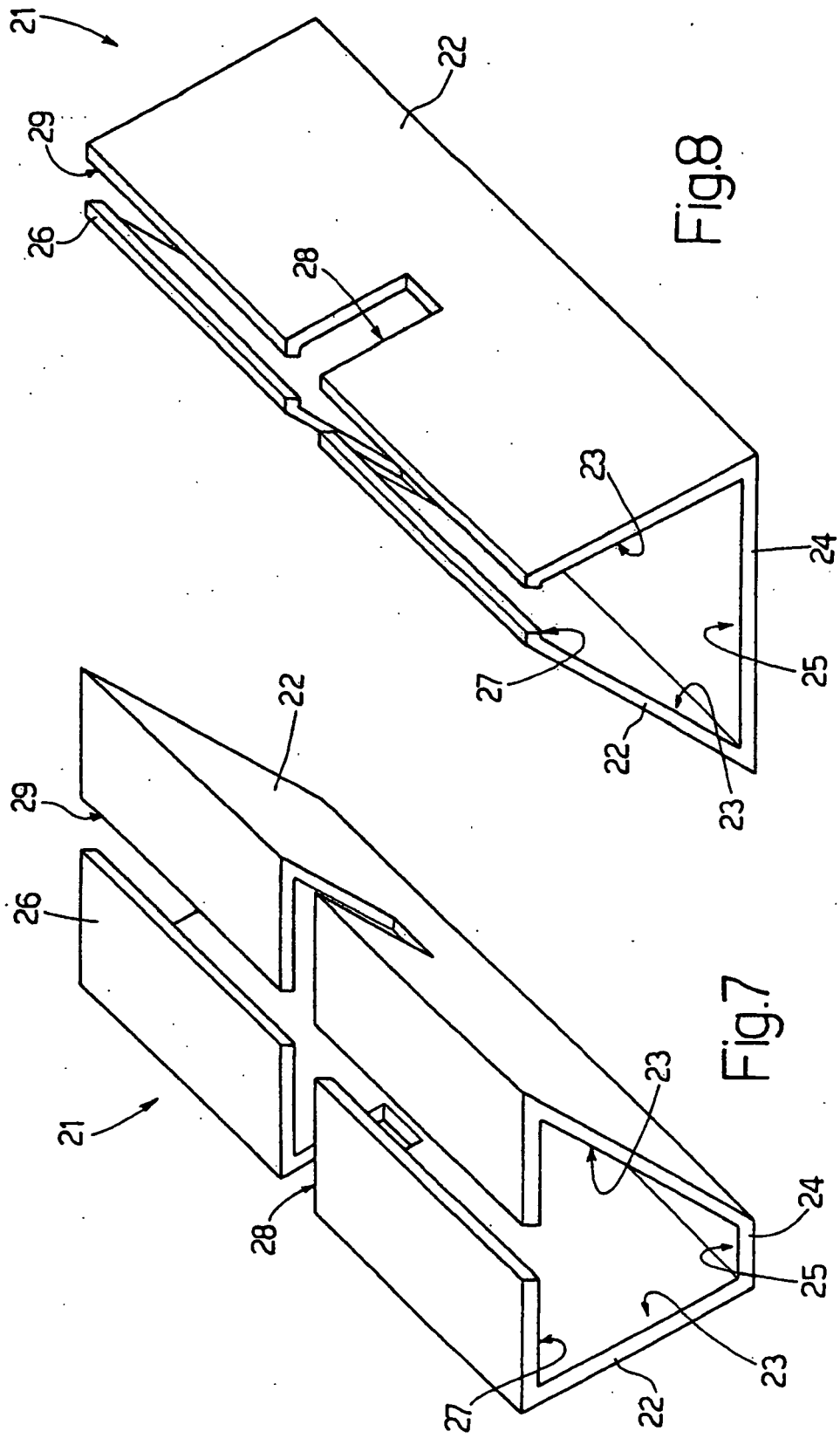

Fig.13



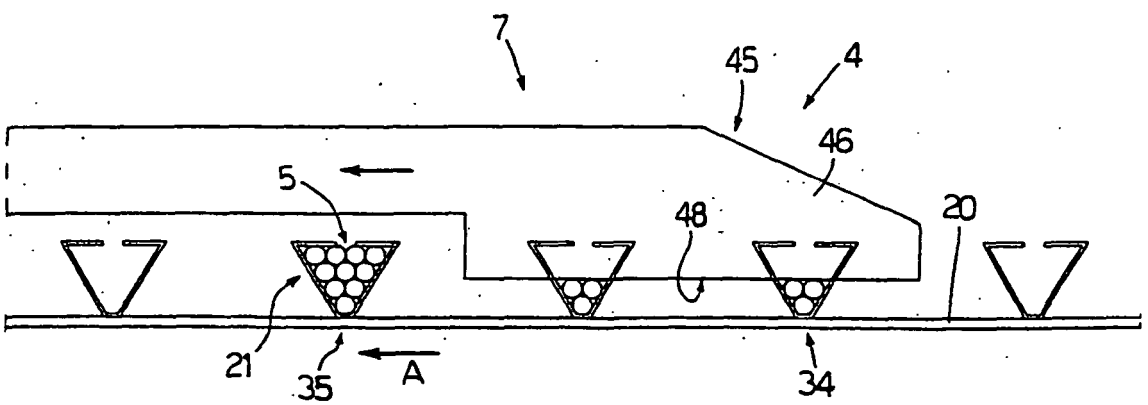
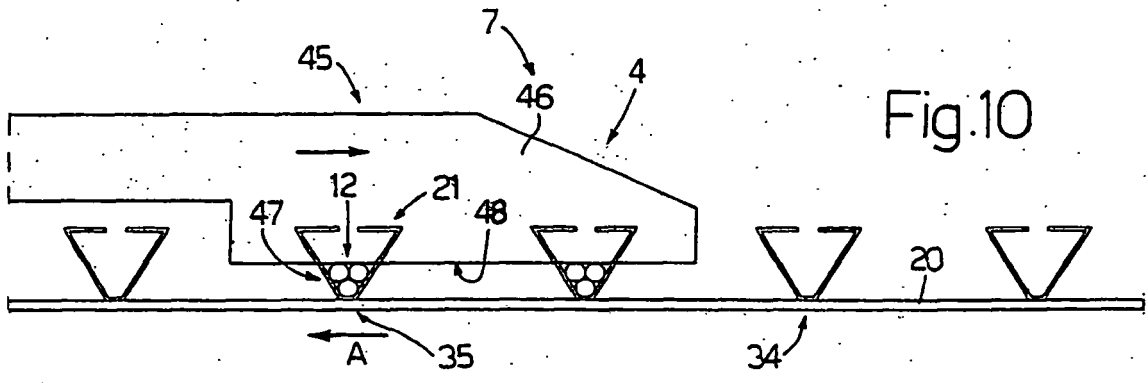
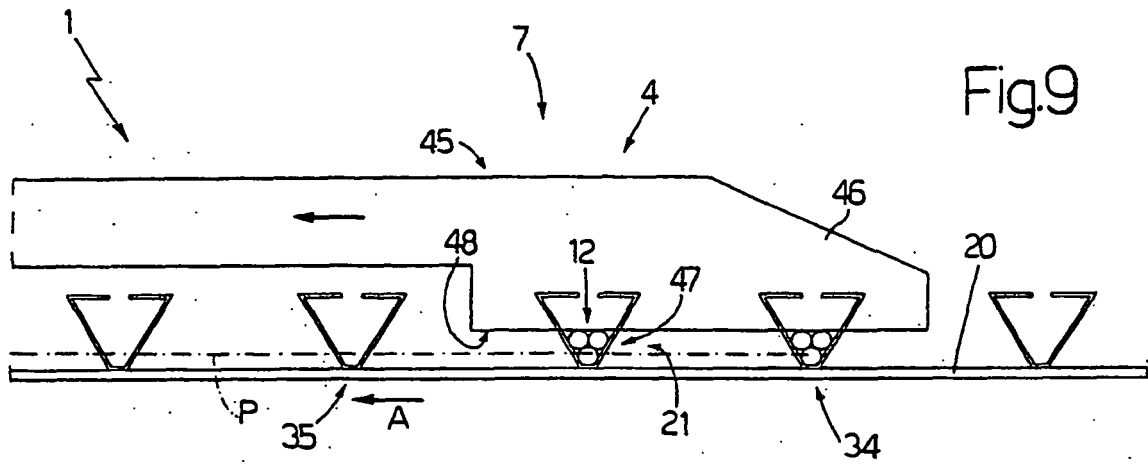

Fig.11

**REFERENCES CITED IN THE DESCRIPTION**

*This list of references cited by the applicant is for the reader's convenience only. It does not form part of the European patent document. Even though great care has been taken in compiling the references, errors or omissions cannot be excluded and the EPO disclaims all liability in this regard.*

**Patent documents cited in the description**

- US 3707219 A [0004]
- US 5590513 A [0005]
- FR 1475759 [0006]
- US 3642112 A [0027]