



(12) **EUROPEAN PATENT APPLICATION**

(43) Date of publication:
16.04.2008 Bulletin 2008/16

(51) Int Cl.:
A62C 37/11 (2006.01)

(21) Application number: **07388074.2**

(22) Date of filing: **11.10.2007**

(84) Designated Contracting States:
AT BE BG CH CY CZ DE DK EE ES FI FR GB GR HU IE IS IT LI LT LU LV MC MT NL PL PT RO SE SI SK TR
 Designated Extension States:
AL BA HR MK RS

(72) Inventor: **Palle, Carsten**
5700 Svendborg (DK)

(74) Representative: **Larsen, Hans Ole et al**
Larsen & Birkeholm A/S,
Banegårdspladsen 1,
P.O. Box 362
1570 Copenhagen V (DK)

(30) Priority: **13.10.2006 DK 200601329**

(71) Applicant: **VID ApS**
5700 Svendborg (DK)

(54) **A water mist nozzle and a method of guiding air in a water mist nozzle**

(57) A water mist nozzle for fire extinguishing and method for guiding a stream of hot air in a water mist nozzle, where the water mist nozzle comprises a water head (2) for releasing water, a heat release element (4) which is heat sensitive, one or more holders (3,5) for holding the heat release element (4), and one or more

fins (6) positioned on the nozzle (2) with an angle of $90^\circ \pm 45^\circ$ between the longitudinal axis of each fin (6) and the longitudinal axis of the heat release element (4) and a distance of 0-5 mm between a fin (6) and the heat release element (4) so that the fins (6) direct air flow (1) to the heat release element (4).

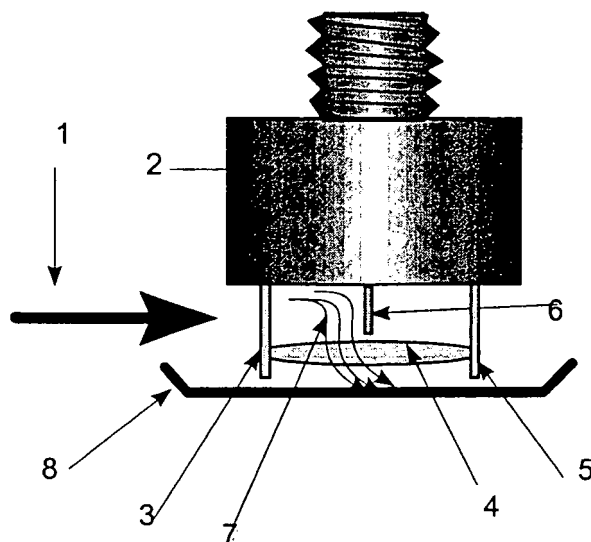

Fig. 1A

Description

The prior art

[0001] The invention concerns a water mist nozzle and method for guiding air in a water mist nozzle for the improvement of time response time index on automatic fire sprinklers classified as Fast Response Sprinkler Heads in accordance with ISO standards for automatic fire sprinklers, and US standards NFPA 13 and NFPA 13R, NFPA 13D, EN 12845, EN-12259-1, Factory Mutual Class No. 5560 and similar installation and approval standards for land based sprinklers and water mist sprinklers for fire protection, as well as the International Maritime Organisation's Resolution A800 etc. for automatic fire sprinklers, and water mist sprinklers for maritime fire protection, as well as for sprinkler and water mist heads for installation in corrosive environments, and environments with vapours, splash and sprays which may cause risks of clogging and similar malfunctions on sprinkler and water mist nozzle heads.

[0002] For an automatic sprinkler head to be recognized and approved to have Fast Response Characteristics in accordance with the mentioned standards, the sprinkler heads must pass a series of standardized time response tests in a standardized test tunnel at various air flow velocities with various air temperatures and with the sprinkler heads installed in various positions to the air flows.

[0003] Automatic sprinkler heads with Fast Response characteristics are known from traditional sprinkler heads as in CA2289974 by Oliver applying a vertically positioned heat release element in the shape of a glass bulb with a diameter of 3 mm or smaller, or a fast response solder link, which is vertically positioned between two open yoke arms, which when installed in ceilings are positioned below or partly below the ceiling surface.

[0004] A problem with these designs is that the sprinkler heads are fully visible in the ceilings.

[0005] An attempt to solve this problem is made in concealed style sprinkler heads as in US4977963 by Simons. In this type of automatic sprinkler heads an automatic yoke style applying a vertically positioned glass bulb with a diameter of 3 mm or less, or a quick response solder link, and a water deflector positioned on two drop pins, are installed in a cup with the large opening facing downwards, and with vent holes at the top of the cup. A cover plate is soldered on to the cup opening with a solder having a low melting point, typically 50°C to 60°C, in a way that leaves an air gap of approximately 1-5 mm between the cup flange and the surface of the cover plate.

[0006] A problem with this type of concealed sprinkler heads is that it is necessary to provide a flow of hot air flowing through the gap between the cover plate and out through the vent holes in the cup to be able to obtain fast response characteristics for the sprinkler heads and, furthermore, that insulating material and dust very often block the vent holes and the air gap and thereby prevent

the sprinkler heads from having true fast response characteristics when installed in ceilings.

[0007] An attempt to solve these problems is made in the flush style sprinkler heads as in US4757865 by Simons. Here a heat collector arrangement is attached to the release element, or a heat collector arrangement is built into the release element. The collector arrangement collects the heat of a fire and transfers the heat through its material directly to the release element.

[0008] The problems with the arrangements are that the sprinkler heads consist of many parts, and that the sprinkler heads become complicated to manufacture.

[0009] Sprinklers and water mist heads for installation in corrosive environments such as saline atmospheres and atmospheres containing ammonia etc. are often made of brass and later coated with wax. Another method is to manufacture the heads in stainless steel or other metals, which are little affected by the corrosive atmosphere.

[0010] Problems with the mentioned methods are that wax coating affects the architectural design of the sprinkler heads, and it complicates storage and installation of the sprinkler heads. Corrosion-resistant metals cause a significant cost increase in the manufacturing of most sprinkler heads.

[0011] Sprinkler and water mist heads for installation in locations with vapours and splash, such as for example above fat fryers, which may cause clogging in the sprinkler head, are often designed as open nozzles which are protected with a cap, and with temperature release from a detector external to the sprinkler or water mist nozzle.

[0012] The problem with this design is that the protection tends to fall off and, furthermore, that the external release mechanism causes an extra and more complicated installation and control of the sprinkler and water mist heads.

The object of the invention

[0013] The object of the invention is to overcome the mentioned problems in relation to automatic concealed sprinkler and water mist heads by decreasing the response time of automatic sprinkler heads and water mist nozzles having a heat release element being a glass bulb, a solder link, or a shape memory alloy in a horizontal position when being tested in an air tunnel, and hereby the invention makes it possible for concealed sprinkler and water mist nozzles to obtain classification, as having Fast Response Characteristics.

[0014] Furthermore, the invention may also comprise a screen between the ambient and the sprinkler nozzle interiors to provide the sprinkler heads with an architecturally closed design, and to protect the sprinkler head interiors from vapours and impurities in the ambient which may cause corrosion or clogging and thus malfunction of the sprinkler head.

[0015] The invention is characterized in comprising one or more fins positioned on an automatic sprinkler or

water mist nozzle, where each fin is positioned with its length line $90^\circ \pm 45^\circ$ to the length line of the heat release element of the sprinkler head or water mist nozzle having a horizontally positioned heat release element or a heat release element positioned $\pm 45^\circ$ to the horizontal level, and where the distance between the fin and the heat release element is 0 - 5 mm.

[0016] When the sprinkler or water mist head is time response tested in an air tunnel, the fin guides the air flow to the close surrounding of the heat release element, which causes a faster heating of the heat response element causing a fast release of the automatic sprinkler or water mist nozzle.

[0017] When, as stated in claim 2, the fin or fins are arranged on a plate or thin foil, which is located on the outlet flange of a sprinkler or water mist nozzle, and each fin is positioned with its length line $90^\circ \pm 45^\circ$ to the length line of the heat release element of a sprinkler head or water mist nozzle having a horizontally positioned heat release element or a heat release element positioned $\pm 45^\circ$ to the horizontal level, and where the distance between the fin and the heat release element is 0-5 mm, the plate or thin foil will serve as a shielding of the sprinkler or water mist nozzle interior, protecting the interior from the surrounding environment, and when the sprinkler or water mist head is time response tested in an air tunnel, the plate guides the air flow to the close surrounding of the heat release element, which causes a faster heating of the heat response element causing a fast release of the automatic sprinkler or water mist nozzle.

[0018] When, as stated in claim 3, the heat release element is a glass bulb, a solder link, or a shape memory alloy the element will be sensitive to heat.

[0019] When, as stated in claim 4, the fin or fins are positioned on the cover plate of an automatic sprinkler or water mist nozzle, where each fin is positioned with its length line $90^\circ \pm 45^\circ$ to the length line of the heat release element of a sprinkler head or water mist nozzle having a horizontally positioned heat release element or a heat release element positioned $\pm 45^\circ$ to the horizontal level, and where the distance between the fin and the heat release element is 0-5 mm, the fin guides the air flow to the close surrounding of the heat release element, which causes a faster heating of the heat response element causing a fast release of the automatic sprinkler or water mist nozzle.

[0020] It is expedient to position the one or more thin fins in a vertical position along a vertically positioned heat release element with a distance of 0-5 mm from the fin to the surface of the release element of an automatic sprinkler or an automatic water mist nozzle as stated in claim 5.

[0021] Finally, as stated in claim 6, it is advantageous if the fins are wider than the yoke arms or cup with holes holding the heat release element in place.

[0022] Thereby, when the sprinkler or water mist head is time response tested in an air tunnel, the fin guides the air flow to the close surrounding of the heat release

element, which causes a faster heating of the heat response element causing a fast release of the automatic sprinkler or water mist nozzle.

5 The drawing

[0023] The invention will be described more fully below with references to the drawing, in which

- 10 Fig. 1A shows an example of the invention with a fin positioned on an automatic sprinkler or water mist head above a horizontally positioned heat release element being a glass bulb,
- Fig. 1B shows the same as figure 1A, but from a different angle,
- 15 Fig. 2 shows an example of the invention where a fin is formed in a plate or foil, which provides a screen at the entrance to the nozzle interior, and where the fin is positioned above a horizontally positioned release element being a glass bulb,
- 20 Fig. 3 shows an example of the invention where a fin is formed to cover around the heat release element of an automatic sprinkler or water mist nozzle, which is concealed by a plate,
- 25 Fig. 4 shows an example of the invention where a fin is positioned on the cover plate of an automatic sprinkler or water mist nozzle having a horizontally positioned heat release element in the shape of a glass bulb,
- 30 Fig. 5 shows an example of the invention where two fins are positioned on an automatic sprinkler or water mist head with a vertically installed heat release element in the shape of a glass bulb positioned in a yoke having two arms, and
- 35 Fig. 6 shows an example of the invention where four fins are positioned on a water mist nozzle having a vertically positioned release element positioned in a yoke having multiple legs.

40 Description of exemplary embodiments

[0024] Figure 1A shows an example of the invention where a fin 6 is positioned on an automatic nozzle head in the shape of a sprinkler or a water mist head 2. The fin 6 is placed above a horizontally positioned heat release element 4, which is fixed between a first holder 3 and a second holder 5 and concealed by a cover plate 8. The heat release element may be a glass bulb 4 or a similar device that is sensitive to heat.

[0025] When the nozzle head is time response tested in an air tunnel, the nozzle is installed in a disadvantageous position where the longitudinal axis of the heat element 4 is positioned at an angle of $\pm 20^\circ$ with respect to the direction of the heated air flow 1.

[0026] In this position the first holder 3 shades the heated air flow 1 from heating the heat release element 4 with a direct stream of hot air, causing the heat release ele-

ment of the nozzle to have a delayed time response. According to the invention the air flow 1 hits the fin 6 outside the shade area of the first holder 3, and the fin 6 directs some of the hot air to flow along the fin and around the surface of the heat release element 4 as indicated by the arrow 7. The heat release element 4 is thereby heated more quickly, causing the nozzle to show a faster time response.

[0027] Figure 2 shows another embodiment of the invention showed in figure 1A. Here the fin 6 is a part of a plate or thin foil 9 that covers the outlet 10 of the water nozzle and thereby protects the interior of the automatic nozzle head in the shape of a sprinkler or a water mist nozzle.

[0028] When the nozzle head is time response tested in an air tunnel, the nozzle is installed in a disadvantageous position where the first holder 3 shields the heated air flow 1 from heating the heat release element 4 with a direct stream of hot air, causing the heat release element of the nozzle to have a delayed time response.

[0029] With the invention the air flow 1 hits the fin 6 outside the area shielded by the holder 3, and the fin 6 directs some of the hot air stream 7 to flow along the fin and the plate surface to surround the heat release element 4, which is thereby heated more quickly by the heated air flow, causing the nozzle to show a faster time response.

[0030] Figure 3 shows an example of the invention where a fin 6 is formed to surround the heat release element 4. When the nozzle head is time response tested in an air tunnel, the nozzle is installed in a disadvantageous position where the first holder 3 shields the heated air flow 1 from heating the heat release element 4 with a direct stream of hot air, causing the heat release element of the nozzle to have a delayed time response.

[0031] With the invention the air flow 1 hits the fin 6 outside the area shielded by the holder 3, and the fin 6 directs some of the hot air stream 7 to flow along the fin 6 and around the surface of the heat release element 4, which is thereby heated more quickly by the heated air flow, causing the nozzle to show a faster time response.

[0032] Figure 4 shows a further embodiment of the invention where a fin 6 is positioned on a cover plate 8, which is positioned below the heat release element 4 of an automatic sprinkler or water mist nozzle.

[0033] When the nozzle head is time response tested in an air tunnel, the nozzle is installed in a disadvantageous position where the first holder 3 shields the heated air flow 1 from heating the heat release element 4 with a direct stream of hot air, causing the heat release element of the nozzle to have a delayed time response.

[0034] With the invention the air flow 1 hits the fin 6 outside the area shielded by the holder 3, and the fin 6 directs some of the hot air stream 7 to flow along the fin 6 and around the surface of the heat release element 4, which is thereby heated more quickly by the heated air flow, causing the nozzle to show a faster time response.

[0035] Figure 5 shows an example of the invention

where two fins 6a, 6b are positioned in a vertical position at the sides of the vertically positioned heat release element 4 of a sprinkler or water mist nozzle having two yoke arms 3,5, and a deflector 8, and with the fins 6a,6b positioned perpendicularly to the nozzle yoke. When the nozzle head is time response tested in an air tunnel, the nozzle is installed in a disadvantageous position where the one holder 3 shielding the heated air flow 1 from heating the heat release element 4 with a direct stream of hot air, causing the heat release element of the nozzle to have a delayed time response.

[0036] With the invention the air flow 1 hits the fins 6 outside the area shielded by the holder 3, and the fins 6 direct some of the hot air stream 7 to flow along the fins and around the surface of the heat release element 4, which is thereby heated more quickly by the heated air flow, causing the nozzle to show a faster time response.

[0037] Figure 6 shows yet another embodiment of the invention where three or more fins 6 are positioned in a vertical position at the side of a hollow cup 11 with holes or slots in which the heat release element 4 of an automatic spray or water mist nozzle is positioned.

[0038] When the nozzle head is time response tested in an air tunnel, the nozzle is installed in a disadvantageous position where the cup material 11 shields the heated air flow 1 from heating the heat release element 4 with a direct stream of hot air, causing the heat release element of the nozzle to have a delayed time response.

[0039] With the invention the air flow 1 hits the fins 6 and the fins direct the hot air through the slots or holes in to the hollow space of the cup 11 and around the surface of the heat release element 4, which is thereby heated more quickly by the heated air flow, causing the nozzle to show a faster time response.

Claims

1. A water mist nozzle for fire extinguishing comprising
 - a water head for releasing water,
 - a heat release element which is heat sensitive and
 - one or more holders for holding the heat release element (4),

characterized in that one or more fins (6) are positioned on the nozzle (2) with an angle of $90^\circ \pm 45^\circ$ between the longitudinal axis of each fin (6) and the longitudinal axis of the heat release element (4) and a distance of 0-5 mm between a fin (6) and the heat release element (4) so that the fins (6) directs air flow (1) to the heat release element (4).

2. A water mist nozzle according to claim 1, **characterized in that** one or more fins (6) are arranged on a plate or thin foil (9) which is located on a flange leading into to the interior of the water mist nozzle (2).

3. A water mist nozzle according to claim 1, **characterized in that** the heat release element (4) is a glass bulb, a solder link, or a shape memory alloy.
4. A water mist nozzle according to claim 1, **characterized in that** one or more fins (6) are positioned on the cover plate (8) of the water mist nozzle (2), and that each fin (6) is positioned with its length line $90^\circ \pm 45^\circ$ to the length line of the heat release element (4) having a horizontally or aslant positioned heat release element (4), and that the distance between the fins (6) and the heat release element (4) is 0-5 mm. 5
10
5. A water mist nozzle according to claim 1, **characterized in that** one or more fins (6) are positioned in a vertical position along a vertically positioned heat release element (4) with a distance of 0-5 mm from the fin (6) to the surface of the heat release element (4) of the water mist nozzle (2). 15
20
6. A water mist nozzle according to claim 5, **characterized in that** the vertically positioned heat release element (4) is held in place by a hollow cup (11) with holes for holding the heat release element (4), and that the fins (6) are wider than the width of the cup (11) so that the air (1) is directed around the cup (11) towards the heat release element (4) for a faster heating. 25
30
7. A method for guiding a stream of hot air in a water mist nozzle comprising
- a water head for releasing water,
 - a heat release element which is heat sensitive and 35
 - one ore more holders for holding the heat release element,
- characterized in that** the air (1) is led onto the heat release element (4) by one or more fins (6) which are arranged in the vicinity of the heat release element. 40

45

50

55

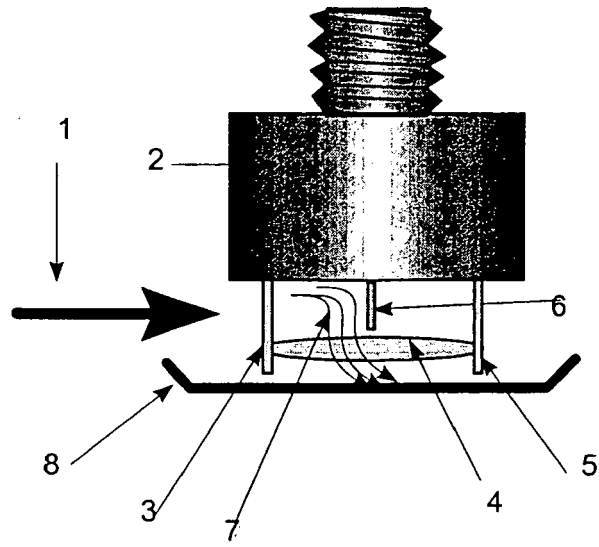

Fig. 1A

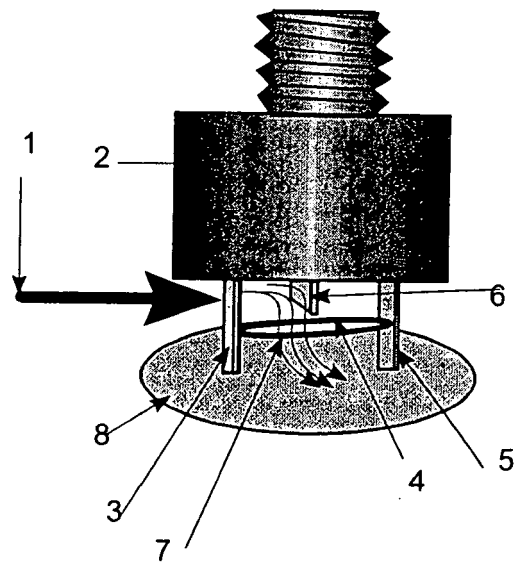

Fig. 1B

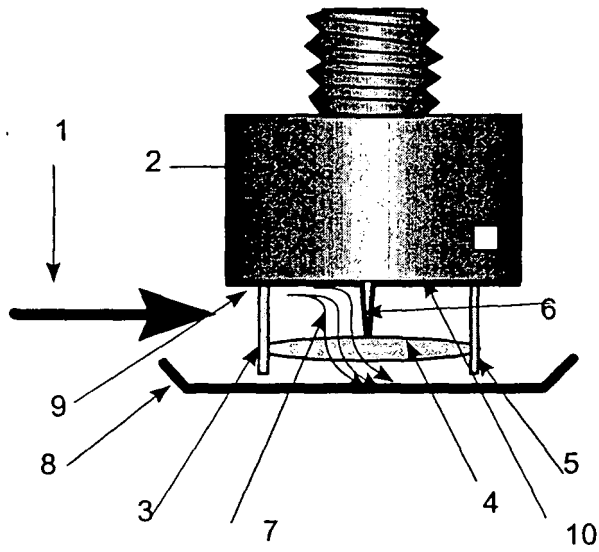

Fig. 2

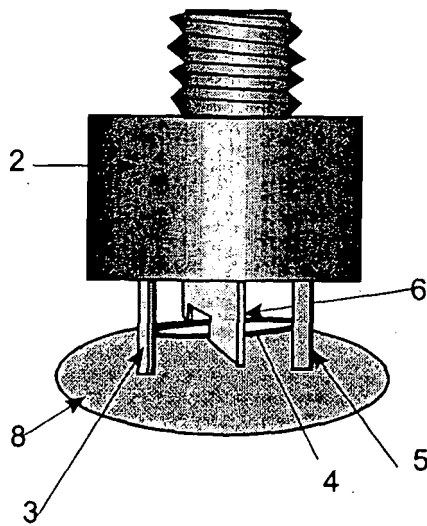

Fig. 3

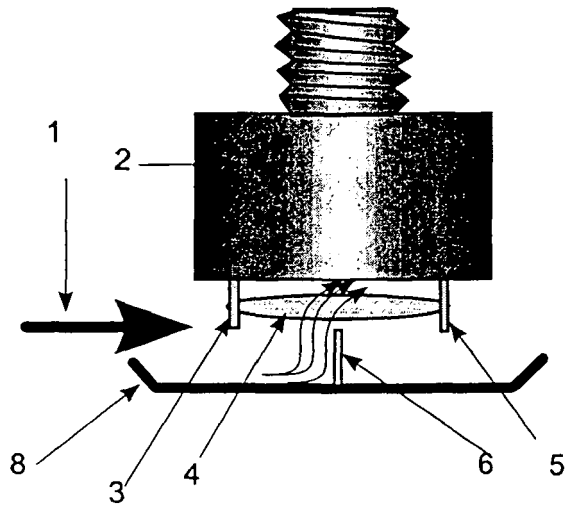

Fig. 4

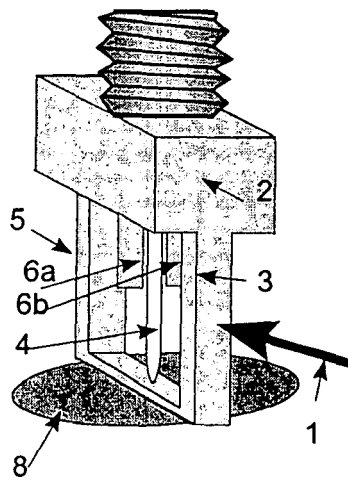

Fig. 5

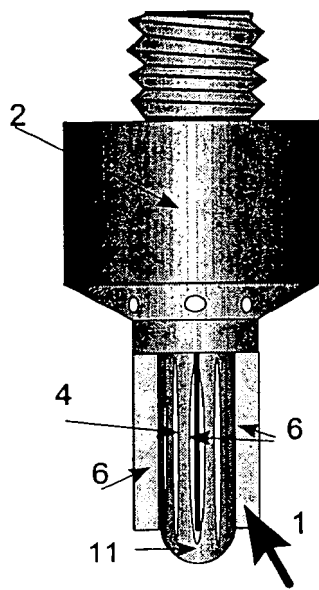

Fig. 6



DOCUMENTS CONSIDERED TO BE RELEVANT			
Category	Citation of document with indication, where appropriate, of relevant passages	Relevant to claim	CLASSIFICATION OF THE APPLICATION (IPC)
X A	GB 2 049 415 A (GRINNELL FIRE PROTECTION) 31 December 1980 (1980-12-31) * the whole document * -----	1,3,7 2,4-6	INV. A62C37/11
X Y A	JP 08 033734 A (NOHMI BOSAI LTD) 6 February 1996 (1996-02-06) * the whole document * -----	1,3,5,7 4 2,6	
X Y A	JP 2005 027929 A (SENJU SPRINKLER KK) 3 February 2005 (2005-02-03) * abstract; figures * -----	7 4 1,3	
The present search report has been drawn up for all claims			TECHNICAL FIELDS SEARCHED (IPC)
			A62C
Place of search		Date of completion of the search	Examiner
The Hague		11 February 2008	Nehrdich, Martin
CATEGORY OF CITED DOCUMENTS			
X : particularly relevant if taken alone Y : particularly relevant if combined with another document of the same category A : technological background O : non-written disclosure P : intermediate document		T : theory or principle underlying the invention E : earlier patent document, but published on, or after the filing date D : document cited in the application L : document cited for other reasons & : member of the same patent family, corresponding document	

1
EPO FORM 1503 03 92 (P04C01)

**ANNEX TO THE EUROPEAN SEARCH REPORT
ON EUROPEAN PATENT APPLICATION NO.**

EP 07 38 8074

This annex lists the patent family members relating to the patent documents cited in the above-mentioned European search report. The members are as contained in the European Patent Office EDP file on
The European Patent Office is in no way liable for these particulars which are merely given for the purpose of information.

11-02-2008

Patent document cited in search report		Publication date	Patent family member(s)	Publication date
GB 2049415	A	31-12-1980	AU 532083 B2	15-09-1983
			AU 5788180 A	06-11-1980
			CA 1138297 A1	28-12-1982
			DE 3016564 A1	06-11-1980
			IT 1128434 B	28-05-1986

JP 8033734	A	06-02-1996	JP 3528099 B2	17-05-2004

JP 2005027929	A	03-02-2005	NONE	

REFERENCES CITED IN THE DESCRIPTION

This list of references cited by the applicant is for the reader's convenience only. It does not form part of the European patent document. Even though great care has been taken in compiling the references, errors or omissions cannot be excluded and the EPO disclaims all liability in this regard.

Patent documents cited in the description

- CA 2289974, Oliver [0003]
- US 4977963 A, Simons [0005]
- US 4757865 A, Simons [0007]