



(11) **EP 1 934 518 B1**

(12) **EUROPEAN PATENT SPECIFICATION**

(45) Date of publication and mention of the grant of the patent:  
**16.09.2009 Bulletin 2009/38**

(21) Application number: **06796055.9**

(22) Date of filing: **16.10.2006**

(51) Int Cl.:  
**F21V 33/00** <sup>(2006.01)</sup> **A47F 3/00** <sup>(2006.01)</sup>  
**A47B 57/00** <sup>(2006.01)</sup> **F21S 4/00** <sup>(2006.01)</sup>  
**F21W 131/301** <sup>(2006.01)</sup>

(86) International application number:  
**PCT/IE2006/000113**

(87) International publication number:  
**WO 2007/043034 (19.04.2007 Gazette 2007/16)**

(54) **AN ILLUMINATOR**

BELEUCHTUNGSVORRICHTUNG

APPAREIL D'ECLAIRAGE

(84) Designated Contracting States:  
**AT BE BG CH CY CZ DE DK EE ES FI FR GB GR HU IS IT LI LT LU LV MC NL PL PT RO SE SI SK TR**

(30) Priority: **14.10.2005 US 726196 P**

(43) Date of publication of application:  
**25.06.2008 Bulletin 2008/26**

(73) Proprietor: **Nualight Limited**  
**Cork (IE)**

(72) Inventors:  
• **KELLY, William**  
**County Cork (IE)**  
• **BOUCHIER, John**  
**County Cavan (IE)**

• **O'SHAUGHNESSY, Paul**  
**County Galway (IE)**  
• **DUKE, Austin**  
**Dublin (IE)**

(74) Representative: **Weldon, Michael James et al**  
**John A. O'Brien & Associates**  
**Third Floor,**  
**Duncairn House,**  
**14 Carysfort Avenue**  
**Blackrock, Co. Dublin (IE)**

(56) References cited:  
**EP-A- 1 222 885** **WO-A-20/06067777**  
**US-A1- 2003 137 828** **US-B1- 6 283 612**

**EP 1 934 518 B1**

Note: Within nine months of the publication of the mention of the grant of the European patent in the European Patent Bulletin, any person may give notice to the European Patent Office of opposition to that patent, in accordance with the Implementing Regulations. Notice of opposition shall not be deemed to have been filed until the opposition fee has been paid. (Art. 99(1) European Patent Convention).

**Description**INTRODUCTIONField of the Invention

**[0001]** The invention relates to illuminators for applications including, for example, display cases or cabinets. Document US 2003/0137828, which is considered to be the closest prior art, discloses an illuminator of this type in accordance with the preamble of claim 1.

**[0002]** At present, illuminators for applications such as retail display cases give rise to problems including having high power consumption, and/or unreliability due to failure of incandescent and fluorescent light sources, and/or costly maintenance, and/or difficulty of retrofitting to existing display cases or cabinets.

**[0003]** The invention addresses these problems.

**[0004]** Another object is to provide an illuminator which is more versatile to manufacture in the factory or to customise on site during installation.

SUMMARY OF THE INVENTION

**[0005]** According to the invention, there is provided an illuminator assembly comprising an illuminator having a housing and at least one light emitting diode mounted on a substrate within the housing, and an illuminator support for mounting the illuminator in a goods cabinet, wherein the illuminator is of elongate shape, and wherein the illuminator support comprises at least one bracket for fitting to a planar goods cabinet shelf or shelf support, the bracket being configured to straddle the shelf or shelf support at an edge thereof and including a support means to engage the housing to support the illuminator, and wherein the housing comprises a platform for the substrate, and wherein the housing comprises at least one receiver for fasteners securing the substrate on the platform, the fastener receiver comprising a channel extending along the length of the housing.

**[0006]** In one embodiment, the housing comprises a housing body of elongate material, and end caps secured to the ends of the housing body.

**[0007]** In one embodiment, the channel comprises side ridges along its length for engagement with screw fastener threads.

**[0008]** In a further embodiment, the housing comprises a base of thermally-conductive material under the substrate to provide a heat transfer path for heat from the substrate.

**[0009]** In one embodiment, the illuminator further comprises a heat transfer material between the substrate and the platform.

**[0010]** In one embodiment, the housing comprises heat transfer fins.

**[0011]** In another embodiment, the fins are substan-

tially parallel and fit within an overall curved outer periphery configuration.

**[0012]** In one embodiment, the cross-sectional shape of the housing is substantially circular.

5 **[0013]** In one embodiment, the illuminator further comprises a cover over the diodes.

**[0014]** In one embodiment, the cover is of flexible material, retained in its shape by engaging the housing on opposed sides.

10 **[0015]** In one embodiment, the housing comprises a pair of opposed grooves to receive and retain opposed side edges of the cover.

**[0016]** In one embodiment, the grooves are configured to allow manual removal and re-insertion of the cover.

15 **[0017]** In a further embodiment, the cover is of transparent plastics or polymer material.

**[0018]** In one embodiment, the substrate comprises modular substrate parts with end terminals for inter-connection.

20 **[0019]** In one embodiment, the diodes comprise diodes of different types to achieve a desired illumination effect.

**[0020]** In one embodiment, the bracket is of U-shaped configuration, having a pair of opposed flanges interconnected by a web, said flanges being configured for gripping a planar shelf or shelf support on opposed surfaces.

25 **[0021]** In one embodiment, the support means allows the housing to be rotated.

30 **[0022]** In one embodiment, the bracket support means allows the housing to be rotated through 360°.

**[0023]** In one embodiment, the support means comprises a seat for an end of the illuminator.

35 **[0024]** In one embodiment, the seat comprises a pair of opposed receivers, and the illuminator comprises a flange for engaging in the receivers.

**[0025]** In a further embodiment, the receivers are inclined downwardly and inwardly towards each other.

40 **[0026]** In one embodiment, the support means comprises an annular support configured to receive an end of the housing.

**[0027]** In one embodiment, the illuminator comprises a flange on a sleeve-shaped coupler secured to a housing main body, said flange being for engagement with the support means.

45 **[0028]** In one embodiment, there is a circumferential groove behind the flange, and the support means engages in the groove.

**[0029]** In one embodiment, the illuminator further comprises a lock for preventing sliding movement of the bracket.

50 **[0030]** In one embodiment, the lock comprises a pin engaging the shelf support.

**[0031]** In another aspect, the invention provides an illuminator comprising:

55 an elongate housing body having a support platform, light emitting diodes mounted on a substrate, in turn

mounted on said platform,

the housing body having a base of thermally-conductive material below the platform and extending along the length of the housing body, said base terminating in heat dissipation fins,

said housing body having a pair of opposed grooves over the substrate, and a resilient transparent cover over the diodes and being snap-fitted in place with opposed edges engaging in said grooves, and

an end cap secured to each end of the housing body.

**[0032]** In one embodiment, the illuminator has a substantially circular cross-sectional shape.

**[0033]** In one embodiment, the illuminator further comprises a circular flange at each end of the illuminator, said flange being configured for engagement with a support means in a manner which allows rotation about a longitudinal axis of the illuminator.

**[0034]** In another aspect, the invention provides a method of manufacturing any illuminator as defined above, the method comprising the steps of:

cutting a length of extruded housing body extrusion material to provide the housing body with a desired length,

cutting a length of cover material to provide the cover with a desired length,

providing at least two modular light emitting diode substrates, and interconnecting them on the platform of the housing body,

snap-fitting the cover in place between the opposed grooves, and

securing the end caps to the ends of the housing body.

**[0035]** In one embodiment, the housing body has a channel running along the length of the platform, and the substrate is secured in place by fastening screws at appropriate locations along the channel.

#### Detailed Description of the Invention

**[0036]** The invention will be more clearly understood from the following description of some embodiments thereof, given by way of example only with reference to the accompanying drawings in which:-

Fig. 1 is a perspective view from above of an illuminator of the invention, and

Fig. 2 is a perspective view from behind;

Figs. 3(a) and (b) are diagrammatic cross-sectional views through the illuminator, showing the configuration of a housing body and how an LED substrate PCB is secured to it;

Fig. 4 is a perspective view of an end cap for the housing;

Fig. 5 is a perspective view of the illuminator during manufacture with mounting fixtures attached;

Figs. 6, 7, and 8 are perspective, end, and side views respectively of a straddle bracket for mounting the illuminator onto conventional shelf supports;

Figs. 9 and 10 are perspective views showing the illuminator being mounted onto the shelf support;

Fig. 11 is an end view showing an illuminator supported by the brackets; and

Figs. 12 and 13 are side and front views showing an alternative illuminator and bracket of the invention.

#### 25 Description of the Embodiments

**[0037]** Referring to the drawings an illuminator 1 is of elongate overall configuration, generally similar to that of a conventional illuminator of the fluorescent tube type. The illuminator 1 comprises a housing body 2 which is a section of a length of extruded aluminium. A transparent polymer cover 3 is snap-fitted in place across a front opening of the housing body 2. There is an end cap 4 at each end of the housing body 2, secured in place by screws into the end faces of the housing 2.

**[0038]** A circuit board 5 is supported on the housing 2, and it is a substrate for LEDs 6 and drive circuits 7.

**[0039]** As shown most clearly in Figs. 3(a) and 3(b) the housing body 2 has a supporting platform 9 for the PCB 5. A channel 10 runs centrally along the length of the housing body 2, acting as a guide and receiver for screws 11 to secure the PCB 5 to the housing body 2. The channel 10 comprises ridges along each side, allowing secure engagement of the screw threads. There is a heat transfer pad 18 between the board 5 and the housing platform 9, allowing optimum thermal contact. Alternatively, there may be a different thermally conductive material such as thermally conductive greases or rubber. If there is a pad, it may have an adhesive.

**[0040]** This arrangement presses the board 5 against the housing 2 so that there is optimum heat transfer from the underside of the board 5 into the housing 2. It also allows the illuminator to be easily assembled during manufacture, and for the PCB to be removed and replaced for any maintenance or upgrade that may be required during its lifetime. Also, there is no need for pre-drilling in the housing 2 for the screws 11 as the channel 10 provides a sufficient guide for engaging screws at any

position.

**[0041]** The housing 2 comprises a base 12 for physical support of the board 5, for overall strength, and for heat transfer. Heat transfer pads 18 and integral fins 13 complete a heat transfer path to the surrounding environment. The edges of the fins are rounded to avoid sharp edges.

**[0042]** The housing body 2 also comprises longitudinal grooves 14 on each lateral side at the front for retaining the transparent cover 3. Because the cover is flexible, it can be easily snap-fitted into position. This allows the cover 3 to be easily fitted during manufacture and to be fitted and removed during the lifecycle of the illuminator. In another embodiment, there is less flexibility in the cover.

**[0043]** It will be appreciated from Figs. 3(a) and 3(b) that the internal surfaces of the housing surrounding the PCB 5 will reflect some light from the LEDs 6, thus optimising the extent of light output and also allowing significant control over the directionality of the light according to the shape of the housing 2. The shape of the housing may be different from that illustrated in order to achieve a different light output pattern with a different extent of reflection from the internal surfaces.

**[0044]** Fig. 4 shows an end cap 4 in more detail. It will be noted that there is a ledge 15 for additional support of the board 5, fixing screw apertures 16, and an aperture 17 for electrical cable 20 for the board.

**[0045]** It will also be appreciated from the drawings that the illuminator may be manufactured with excellent versatility in terms of its length. One must only cut the extruded aluminium housing body 2 to the desired section length and cut the plastics cover 3 accordingly. The PCB 5 is in modular sections with terminals for interconnection. Indeed it is envisaged that the illuminator may even be customised on site to suit the display case into which it is being fitted.

**[0046]** Referring to Fig. 5 the illuminator 1 also comprises mounting couplers 25 secured by grub screws. Each coupler 25 is of tubular shape, and at its outer extremity there is a circumferential groove 26 defining an end flange 27. The cable 20 is trained through the coupler 25.

**[0047]** The couplers 25, together with straddle brackets 30, allow the illuminator to be easily and securely mounted onto conventional shelf supports or brackets B, for retrofitting or original installation. As shown in Figs. 6 to 8 inclusive each straddle bracket 30 comprises a top web 31 and two downwardly-depending flanges 32, forming together an inverted U-shaped configuration. The flanges 32 have corresponding vertical slots 33 to accommodate the cable 20. Also, there is a pair of receivers 34 and 35 on each flange 32, together forming a seat. Each receiver extends at an angle between vertical and horizontal tapered downwardly towards each other. Each receiver 34, 35 comprises a pressed-out length of the bracket metal forming a slot to receive the end flange 27.

**[0048]** Referring to Figs. 9, 10, and 11 on one side of a straddle bracket 30 the pair of receivers 35 together

form a seat to receive the flange 27 of a coupler 25. Because of the angles at which the receivers 34 and 35 are inclined they form a particularly stable seat for the ends of the illuminator 1, and furthermore they allow the illuminator to be rotated for optimum direction of the light. The illuminator further comprises a fixture which is secured to the shelf support B by engagement of a pin in an aperture of the shelf support. This is secured in place at a location to prevent sliding of a straddle bracket 30.

**[0049]** It will also be appreciated that the sleeve-shaped couplers 25 and the straddle brackets 30 allow the illuminator to be easily and quickly mounted in a display cabinet having conventional shelf supports or brackets B, allowing very easy retrofitting. What has been achieved is excellent illuminator support stability, versatility for rotation to a desired illumination direction, and very simple fitting/installation either retrofitted or original. Fig. 11 in particular shows how the top web 31 of the bracket 30 is matched in height by a fixture 40 over the shelf support B to ensure horizontal mounting of the shelf S.

**[0050]** The illuminator, when installed, can be rotated to any desired orientation so that it may for example illuminate items on a shelf underneath it. Alternatively, it may be upwardly directed to illuminate items above it through a glass shelf supported on the shelf support brackets.

**[0051]** Another advantage of the illuminator is that the manufacturer can easily choose illumination parameters by simply choosing the desired configuration of modular boards 5. For example, there may be a specific chosen pattern of different LEDs to achieve a particular illumination effect. Another versatile parameter is the length of the housing body 2, and hence of the illuminator.

**[0052]** It will be appreciated that the illuminator has a similar physical configuration to a conventional fluorescent illuminator, allowing the latter to be replaced with illuminators which do not give rise to hazardous waste disposal issues. Indeed, it is envisaged that, in another embodiment, the illuminator may be configured to fit into a support and power supply of a conventional fluorescent illuminator. Thus the illuminator may be supplied as a plug-in replacement for a fluorescent tube, with the fluorescent tube electrical supply providing power to the circuit. The power supply may be mains or down-converted AC or DC depending upon the illumination requirements. This embodiment may include a safety feature for bypassing or disconnecting a ballast to ensure that high voltages are not applied.

**[0053]** In use; it is preferable that a pair of opposed straddle brackets 30 supports an illuminator, however with suitable configuration of the brackets and couplers (and possible size and weight of housing) a single straddle bracket may provide cantilevered support. This allows further versatility.

**[0054]** It is also envisaged that the illuminator may form part of a frame of a display case, such as a mullion.

**[0055]** Referring to Figs. 12 and 13 in another embod-

iment a bracket 50 has a U-shaped shelf edge surround 51 for straddling the front edge of a shelf S and a screw 52 to secure the bracket 51 in place. The lower flange of the surround 51 is secured to a depending and circular illuminator support 53 through which the illuminator coupler 25 fits. Again, this allows the illuminator to be easily retro-fitted to an existing cabinet, and to be rotated to an optimum illumination position.

**[0056]** In a further embodiment, an illuminator support may have a bracket similar to the bracket 50, but the support means may be similar to the arrangement in the bracket 30, with opposed cut-outs or grooves forming a seat for the ends of the illuminator.

**[0057]** The invention is not limited to the embodiments described but may be varied in construction and detail, within the scope of the appended claims.

### Claims

1. An illuminator assembly comprising an illuminator (1) having a housing (2, 3, 25) and at least one light emitting diode (6) mounted on a substrate (5) within the housing, and an illuminator support (25, 30) for mounting the illuminator in a goods cabinet, wherein the illuminator (1) is of elongate shape, and wherein the illuminator support (25, 30) comprises at least one bracket (30) for fitting to a planar goods cabinet shelf or shelf support (S), the bracket being configured to straddle the shelf or shelf support at an edge thereof and including a support means (34, 35) to engage the housing to support the illuminator; and wherein the housing comprises a platform (9) for the substrate (5), **characterised in that** the housing comprises at least one receiver for fasteners (11) securing the substrate on the platform (9), the fastener receiver comprising a channel extending along the length of the housing.
2. An illuminator assembly as claimed in claim 1, wherein the housing comprises a housing body (2) of elongate material, and end caps (4) secured to the ends of the housing body.
3. An illuminator assembly as claimed in either of claims 1 or 2, wherein the channel comprises side ridges along its length for engagement with screw fastener threads.
4. An illuminator assembly as claimed in any preceding claim, wherein the housing comprises a base (10) of thermally-conductive material under the substrate to provide a heat transfer path for heat from the substrate; and wherein the illuminator further comprises a heat transfer material (18) between the substrate and the platform (9).
5. An illuminator assembly as claimed in any preceding claim, wherein the housing comprises heat transfer fins (13) which are substantially parallel and fit within an overall curved outer periphery configuration.
6. An illuminator assembly as claimed in any preceding claim, wherein the cross-sectional shape of the housing is substantially circular.
7. An illuminator assembly as claimed in any preceding claim, further comprising a cover (3) over the diodes (6); and wherein the cover (3) is of flexible material, retained in its shape by engaging the housing on opposed sides.
8. An illuminator assembly as claimed in claim 7, wherein the housing comprises a pair of opposed grooves (14) to receive and retain opposed side edges of the cover; and wherein the grooves (14) are configured to allow manual removal and re-insertion of the cover.
9. An illuminator assembly as claimed in either of claims 7 to 8, wherein the cover (3) is of transparent plastics or polymer material.
10. An illuminator assembly as claimed in any preceding claim, wherein the substrate comprises modular substrate parts with end terminals for interconnection.
11. An illuminator assembly as claimed in any preceding claim, wherein the bracket (30, 51) is of U-shaped configuration, having a pair of opposed flanges interconnected by a web, said flanges being configured for gripping a planar shelf or shelf support on opposed surfaces.
12. An illuminator assembly as claimed in claim 11, wherein the support means allows the housing to be rotated.
13. An illuminator assembly as claimed in claim 12, wherein the support means comprises a seat (34, 35) for an end of the illuminator; and wherein the seat comprises a pair of opposed receivers (34, 35), and the illuminator comprises a flange (27) for engaging in the receivers.
14. An illuminator assembly as claimed in claim 13, wherein the receivers are inclined downwardly and inwardly towards each other.
15. An illuminator assembly as claimed in claim 12, wherein the support means comprises an annular support (53) configured to receive an end of the housing.

16. An illuminator assembly as claimed in any preceding claim, wherein the illuminator comprises a flange (27) on a sleeve-shaped coupler (25) secured to a housing main body (2), said flange being for engagement with the support means; and wherein there is a circumferential groove (26) behind the flange, and the support means engages in the groove.

17. A method of manufacturing an illuminator as claimed in any of claims 7 to 16, the method comprising the steps of:

cutting a length of extruded housing body extrusion material to provide the housing body (2) with a desired length,  
cutting a length of cover material to provide the cover (3) with a desired length,  
providing at least two modular light emitting diode substrates, and interconnecting them on the platform (9) of the housing body,  
snap-fitting the cover (3) in place between the opposed grooves (14),  
securing the end caps (4) to the ends of the housing body; and

wherein the housing body has a channel running along the length of the platform (9), and the substrate is secured in place by fastening screws at appropriate locations along the channel.

#### Patentansprüche

1. Beleuchtungsbaugruppe, die eine Beleuchtungseinrichtung (1) mit einem Gehäuse (2, 3, 25) und mindestens einer Leuchtdiode (6) angebracht auf einem Substrat (5) innerhalb des Gehäuses, sowie einen Beleuchtungsträger (25, 30) zum Anbringen der Beleuchtungseinrichtung in einer Warenvitrine umfasst, wobei die Beleuchtungseinrichtung (1) eine längliche Form hat, und wobei der Beleuchtungsträger (25, 30) mindestens einen Halter (30) zum Einpassen an einem ebenen Warenvitrinenregalboden oder Regalbodenträger (S) umfasst, wobei der Halter konfiguriert ist, um den Regalboden oder Regalbodenträger an einer Kante desselben zu überspannen und ein Trägermittel (34, 35) zum Ergreifen des Gehäuses zum Tragen der Beleuchtungseinrichtung einschließt; und wobei das Gehäuse eine Plattform (9) für das Substrat (5) aufweist, **dadurch gekennzeichnet, dass** das Gehäuse mindestens eine Aufnahme für Befestigungen (11) umfasst, die das Substrat auf der Plattform (9) befestigen, wobei die Befestigungsaufnahme einen Kanal aufweist, der sich über die Länge des Gehäuses erstreckt.
2. Beleuchtungsbaugruppe nach Anspruch 1, bei der das Gehäuse einen Gehäusekörper (2) aus länglichem Material und Endkappen (4) umfasst, die an den Enden des Gehäusekörpers befestigt werden.
3. Beleuchtungsbaugruppe nach einem der Ansprüche 1 oder 2, bei der der Kanal Seitenleisten entlang seiner Länge zum Eingriff mit Gewinden von Schraubbefestigungen umfasst.
4. Beleuchtungsbaugruppe nach einem vorhergehenden Anspruch, bei der das Gehäuse eine Basis (10) aus wärmeleitendem Material unter dem Substrat umfasst, um einen Wärmeübertragungsweg für Wärme von dem Substrat bereitzustellen, und wobei die Beleuchtungseinrichtung ferner ein Wärmeübertragungsmaterial (18) zwischen dem Substrat und der Plattform (9) umfasst.
5. Beleuchtungsbaugruppe nach einem vorhergehenden Anspruch, bei der das Gehäuse Wärmeübertragungsrippen (13) umfasst, die im Wesentlichen parallel sind und in eine gebogene Gesamtaußenumfangskonfiguration passen.
6. Beleuchtungsbaugruppe nach einem vorhergehenden Anspruch, bei der die Querschnittsform des Gehäuses im Wesentlichen kreisförmig ist.
7. Beleuchtungsbaugruppe nach einem vorhergehenden Anspruch, die weiter eine Abdeckung (3) über den Dioden (6) umfasst; und wobei die Abdeckung (3) aus flexiblem Material besteht, das durch Ergreifen des Gehäuses an gegenüberliegenden Seiten in seiner Form gehalten wird.
8. Beleuchtungsbaugruppe nach Anspruch 7, bei der das Gehäuse ein Paar gegenüberliegender Nuten (14) zum Aufnehmen und Festhalten gegenüberliegender Seitenkanten der Abdeckung aufweist; und wobei die Nuten (14) konfiguriert sind, um manuelle Entfernung und Wiedereinführung der Abdeckung zu ermöglichen.
9. Beleuchtungsbaugruppe nach einem der Ansprüche 7 oder 8, bei der die Abdeckung (3) aus durchsichtigem Kunststoff- oder Polymermaterial besteht.
10. Beleuchtungsbaugruppe nach einem vorhergehenden Anspruch, bei der das Substrat modulare Substratteile mit Endanschlüssen zur gegenseitigen Verbindung umfasst.
11. Beleuchtungsbaugruppe nach einem vorhergehenden Anspruch, bei der der Halter (30, 51) eine U-förmige Konfiguration aufweist, die ein Paar gegenüberliegender Flansche verbunden durch einen Steg enthält, wobei die Flansche zum Ergreifen ei-

nes ebenen Regalbodens oder Regalbodenträgers an gegenüberliegenden Oberflächen konfiguriert sind.

12. Beleuchtungsbaugruppe nach Anspruch 11, bei der das Trägermittel Rotieren des Gehäuses ermöglicht.
13. Beleuchtungsbaugruppe nach Anspruch 12, bei der das Trägermittel einen Sitz (34, 35) für ein Ende der Beleuchtungseinrichtung umfasst; und bei der der Sitz ein Paar gegenüberliegender Aufnahmen (34, 35) umfasst; und die Beleuchtungseinrichtung einen Flansch (27) zum Eingreifen in die Aufnahmen umfasst.
14. Beleuchtungsbaugruppe nach Anspruch 13, bei der die Aufnahmen nach unten und nach innen zueinander hin geneigt sind.
15. Beleuchtungsbaugruppe nach Anspruch 12, bei der das Trägermittel einen Ringträger (53) umfasst, der zum Aufnehmen eines Endes des Gehäuses konfiguriert ist.
16. Beleuchtungsbaugruppe nach einem vorhergehenden Anspruch, bei der die Beleuchtungseinrichtung einen Flansch (27) an einem hülsenförmigen Verbindungsstück (25) aufweist, das an einem Gehäusehauptkörper (2) befestigt ist, wobei der Flansch zum Eingriff mit dem Trägermittel vorgesehen ist; und bei der sich eine umlaufende Nut (26) hinter dem Flansch befindet und das Trägermittel in die Nut eingreift.
17. Verfahren zum Herstellen einer Beleuchtungseinrichtung nach einem der Ansprüche 7 bis 16, wobei das Verfahren die folgenden Schritte umfasst:

Zuschneiden einer Länge von extrudiertem Gehäusekörper-Extrusionsmaterial zum Bereitstellen des Gehäusekörpers (2) mit einer gewünschten Länge,  
 Zuschneiden einer Länge von Abdeckmaterial zum Bereitstellen der Abdeckung (3) mit einer gewünschten Länge,  
 Bereitstellen von mindestens zwei modularen Leuchtdiodensubstraten, und Verbinden derselben auf einer Plattform (9) des Gehäusekörpers, Einschnappen der Abdeckung (3) an richtiger Stelle zwischen den gegenüberliegenden Nuten (14),  
 Befestigen der Endkappen (4) an den Enden des Gehäusekörpers; und

wobei der Gehäusekörper einen Kanal aufweist, der entlang der Länge der Plattform (9) verläuft, und das Substrat durch Befestigungsschrauben an geeigneten Stellen entlang des Kanals an richtiger Stelle be-

festigt wird.

## Revendications

- Ensemble appareil d'éclairage comportant un appareil d'éclairage (1) ayant un logement (2, 3, 25) et au moins une diode électroluminescente (6) montée sur un substrat (5) à l'intérieur du logement, et un support pour appareil d'éclairage (25, 30) à des fins de montage de l'appareil d'éclairage dans un meuble vitrine d'objets, dans lequel l'appareil d'éclairage (1) est de forme allongée, et dans lequel le support pour appareil d'éclairage (25, 30) comporte au moins une patte de fixation (30) à des fins de fixation sur un support de rayon ou rayon de forme plane pour meuble vitrine d'objets (S), la patte de fixation étant configurée pour chevaucher le support de rayon ou rayon au niveau d'un bord de celui-ci et comprenant un moyen de support (34, 35) à des fins de mise en prise du logement pour supporter l'appareil d'éclairage ; et dans lequel le logement comporte une plate-forme (9) pour le substrat (5), **caractérisé en ce que** le logement comporte au moins un élément récepteur pour des attaches de fixation (11) permettant d'assujettir le substrat sur la plate-forme (9), l'élément récepteur pour attaches de fixation comportant un profilé en U s'étendant sur toute la longueur du logement.
- Ensemble appareil d'éclairage selon la revendication 1, dans lequel le logement comporte un corps de logement (2) de matériau allongé, et des embouts (4) assujettis aux extrémités du corps de logement.
- Ensemble appareil d'éclairage selon la revendication 1 ou la revendication 2, dans lequel le profilé en U comporte des stries latérales sur toute sa longueur à des fins de mise en prise avec les filets des attaches de fixation à vis.
- Ensemble appareil d'éclairage selon l'une quelconque des revendications précédentes, dans lequel le logement comporte une base (10) de matériau thermoconducteur sous le substrat pour mettre en oeuvre une trajectoire de transfert de chaleur pour la chaleur en provenance du substrat ; et dans lequel l'appareil d'éclairage comporte par ailleurs un matériau caloporteur (18) entre le substrat et la plate-forme (9).
- Ensemble appareil d'éclairage selon l'une quelconque des revendications précédentes, dans lequel le logement comporte des ailettes caloporteuses (13) qui sont dans une large mesure parallèles et s'adaptent à l'intérieur d'une configuration périphérique ex-

- térieure courbe générale.
6. Ensemble appareil d'éclairage selon l'une quelconque des revendications précédentes, dans lequel la forme en coupe du logement est dans une large mesure circulaire.
7. Ensemble appareil d'éclairage selon l'une quelconque des revendications précédentes, comportant par ailleurs un couvercle (3) sur les diodes (6) ; et dans lequel le couvercle (3) est d'un matériau flexible, retenu dans sa forme par la mise en prise du logement au niveau des côtés opposés.
8. Ensemble appareil d'éclairage selon la revendication 7, dans lequel le logement comporte une paire de rainures opposées (14) destinées à recevoir et retenir des bords latéraux opposés du couvercle ; et dans lequel les rainures (14) sont configurées pour permettre d'effectuer manuellement le retrait et la réinsertion du couvercle.
9. Ensemble appareil d'éclairage selon la revendication 7 ou la revendication 8, dans lequel le couvercle (3) est d'un matériau polymère ou plastique transparent.
10. Ensemble appareil d'éclairage selon l'une quelconque des revendications précédentes, dans lequel le substrat comporte des pièces de substrat modulaires avec des bornes d'extrémité à des fins d'interconnexion.
11. Ensemble appareil d'éclairage selon l'une quelconque des revendications précédentes, dans lequel la patte de fixation (30, 51) est d'une configuration en forme de U, ayant une paire de rebords opposés interconnectés par une bande, lesdits rebords étant configurés pour saisir un support de rayon ou rayon de forme plane sur des surfaces opposées.
12. Ensemble appareil d'éclairage selon la revendication 11, dans lequel le moyen de support permet la rotation du logement.
13. Ensemble appareil d'éclairage selon la revendication 12, dans lequel le moyen de support comporte un siège (34, 35) pour une extrémité de l'appareil d'éclairage ; et dans lequel le siège comporte une paire d'éléments récepteurs opposés (34, 35), et l'appareil d'éclairage comporte un rebord (27) à des fins de mise en prise dans les éléments récepteurs.
14. Ensemble appareil d'éclairage selon la revendication 13, dans lequel les éléments récepteurs sont inclinés vers le bas et vers l'intérieur l'un vers l'autre.
15. Ensemble appareil d'éclairage selon la revendication 12, dans lequel le moyen de support comporte un support annulaire (53) configuré pour recevoir une extrémité du logement.
16. Ensemble appareil d'éclairage selon l'une quelconque des revendications précédentes, dans lequel l'appareil d'éclairage comporte un rebord (27) sur une pièce d'accouplement en forme de manchon (25) assujettie sur un corps principal (2) de logement, ledit rebord étant pourvu à des fins de mise en prise avec le moyen de support ; et dans lequel il y a une rainure circonférentielle (26) derrière le rebord, et le moyen de support entre en prise dans la rainure.
17. Procédé de fabrication d'un appareil d'éclairage selon l'une quelconque des revendications 7 à 16, le procédé comportant les étapes consistant à :
- découper une longueur de matériau d'extrusion de corps de logement extrudé pour mettre en oeuvre le corps (2) de logement selon une longueur souhaitée,
- découper une longueur de matériau de couvercle pour mettre en oeuvre le couvercle (3) selon une longueur souhaitée,
- mettre en oeuvre au moins deux substrats modulaires pour diode électroluminescente, et les interconnecter sur la plate-forme (9) du corps de logement,
- mettre le couvercle (3) en place par pression entre les rainures opposées (14),
- assujettir les embouts (4) aux extrémités du corps de logement ; et
- dans lequel le corps de logement a un profilé en U s'acheminant sur toute la longueur de la plate-forme (9), et le substrat est assujetti en place par la fixation de vis en des endroits appropriés le long du profilé en U.

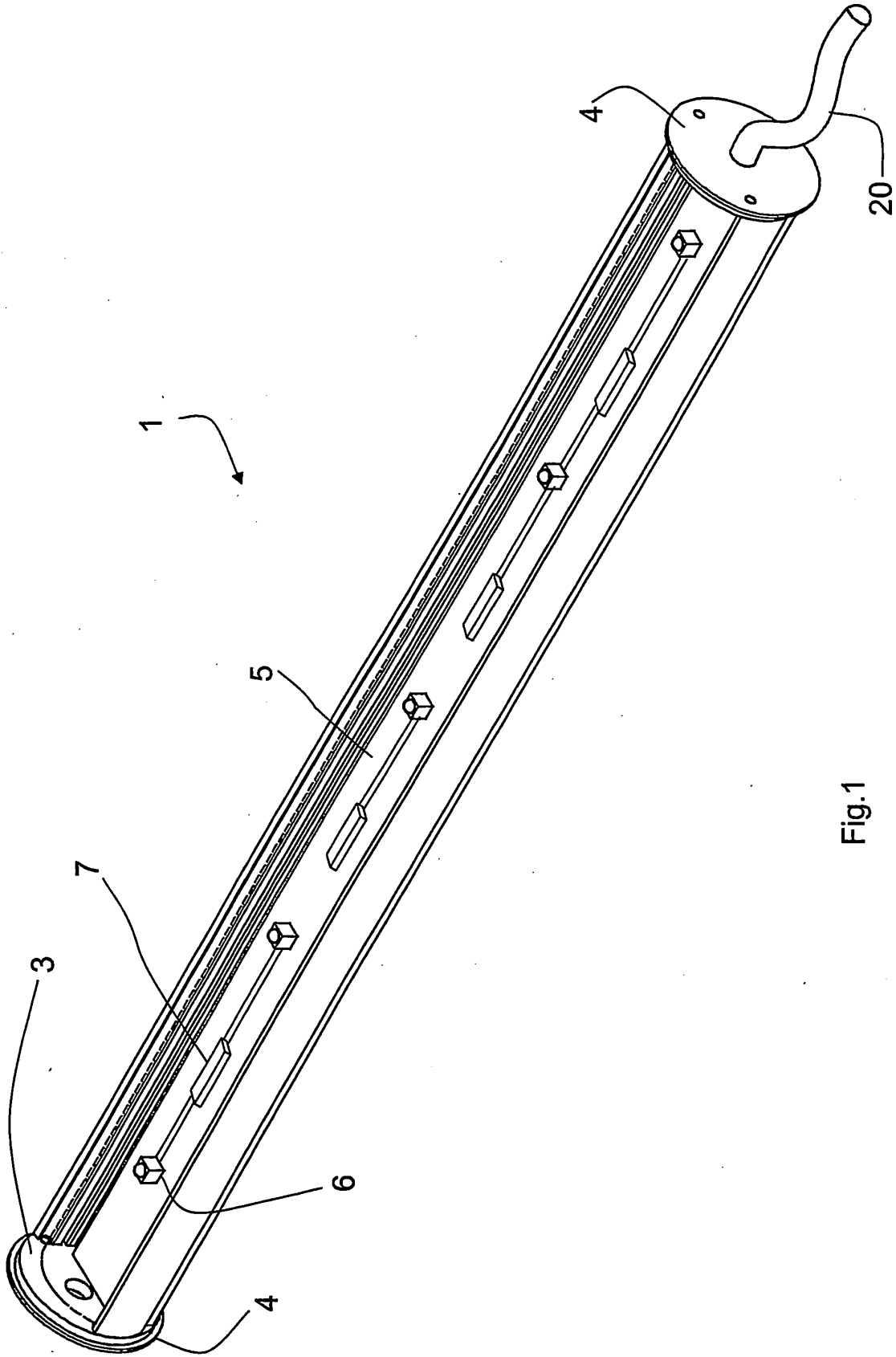
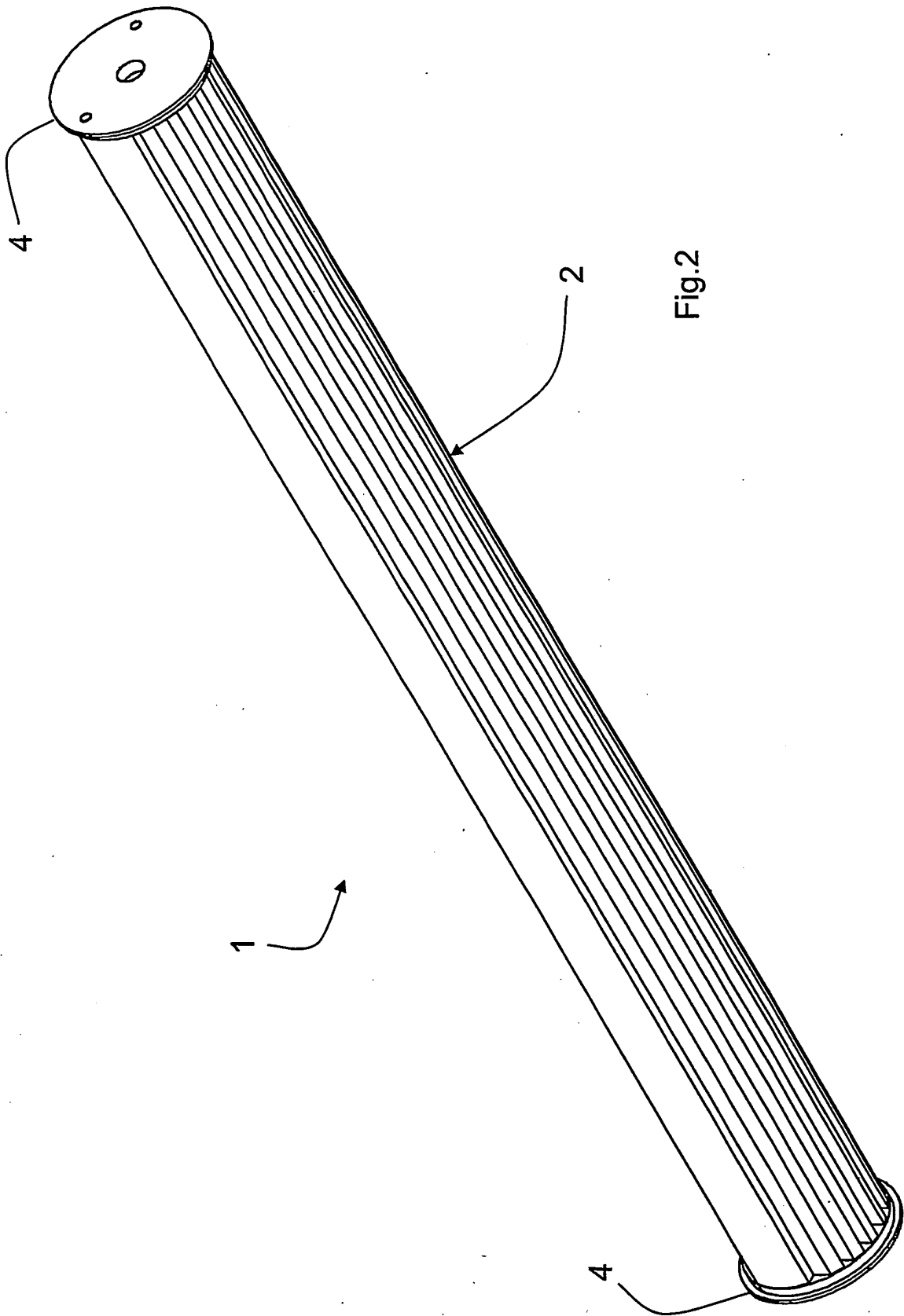
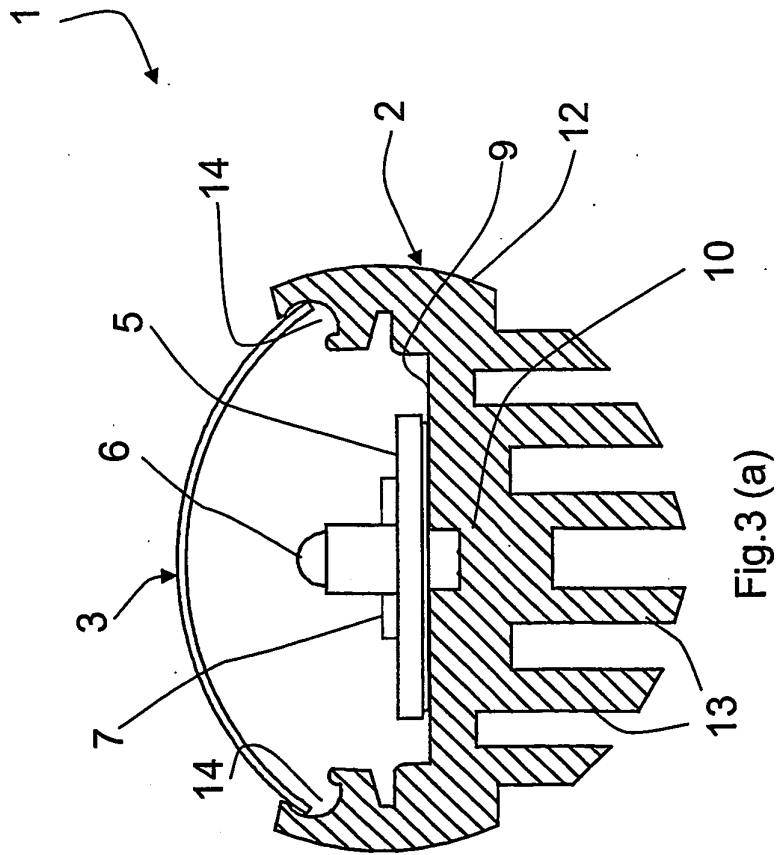
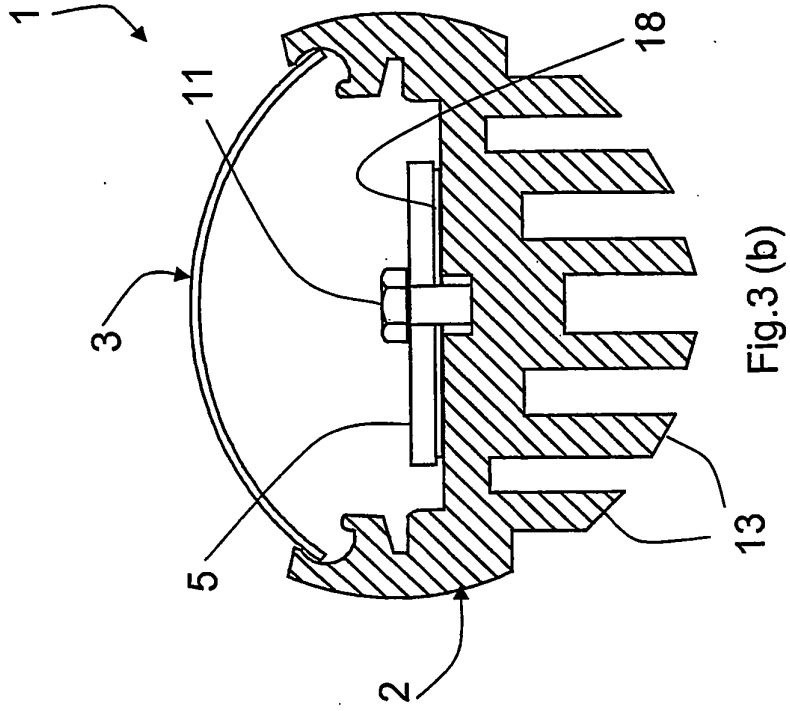

Fig.1





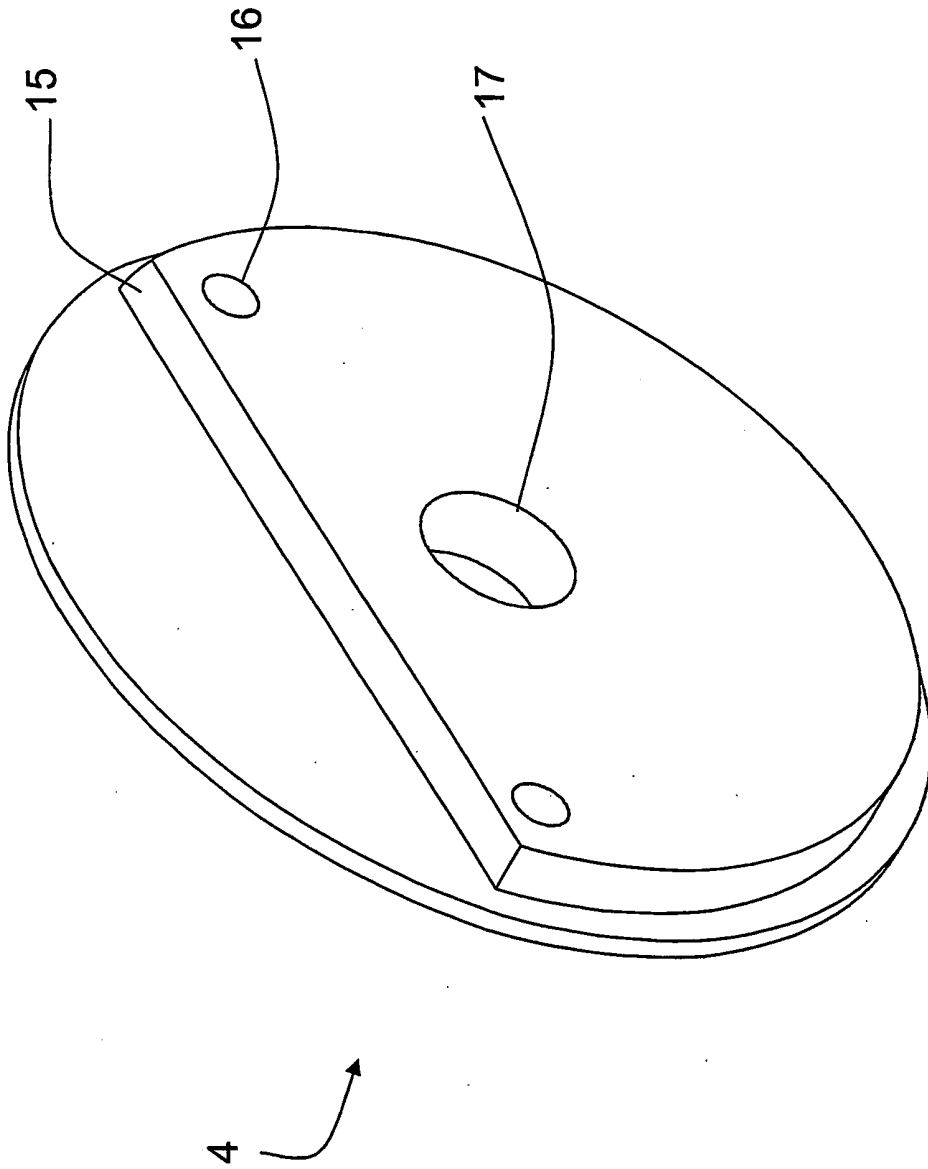

Fig.4

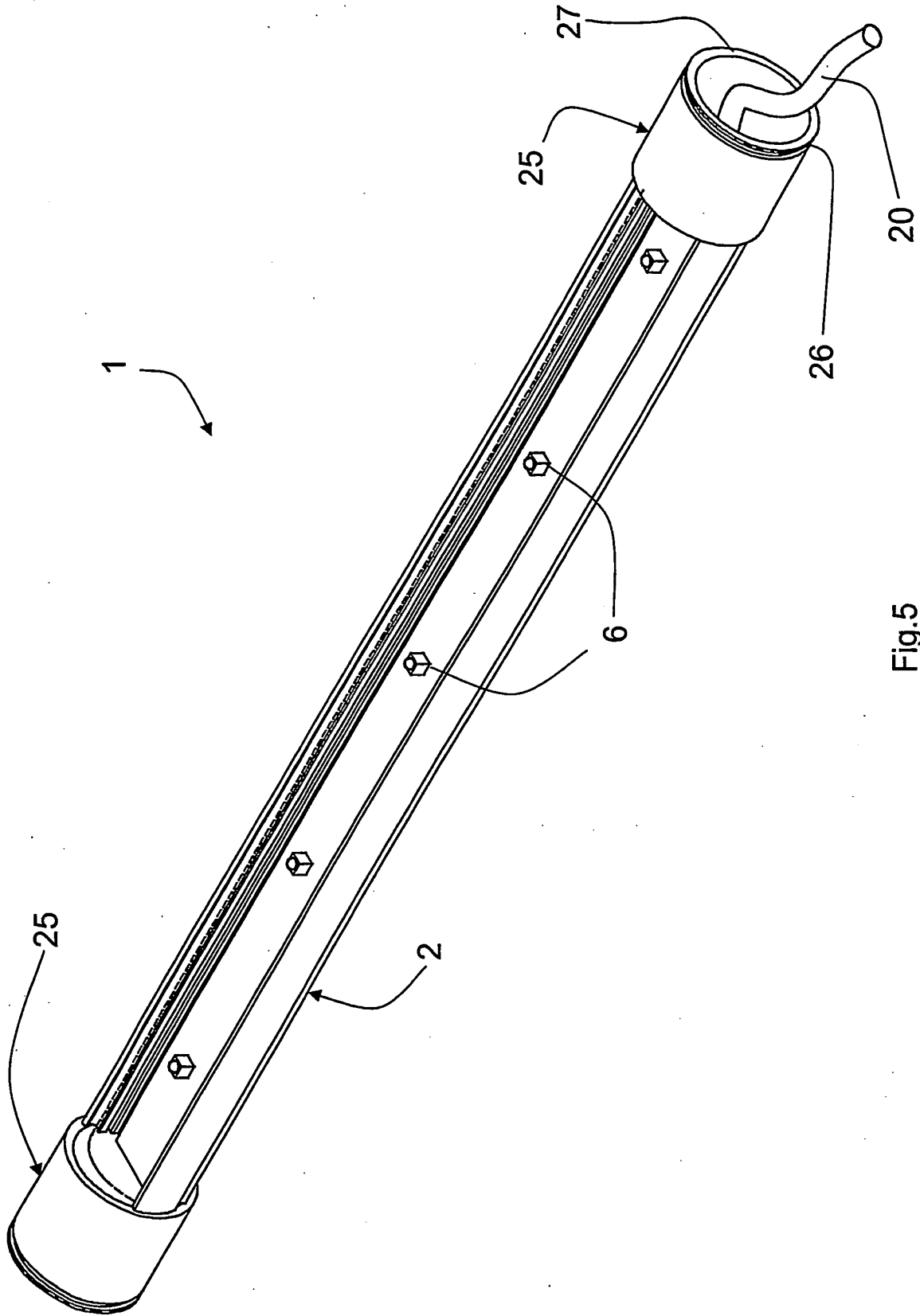

Fig.5

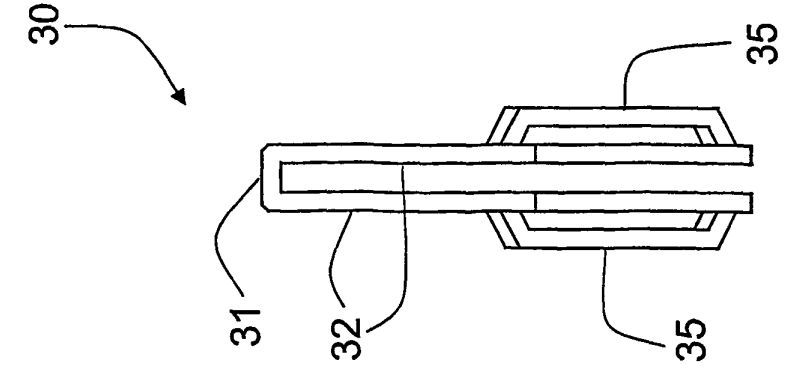

Fig.8

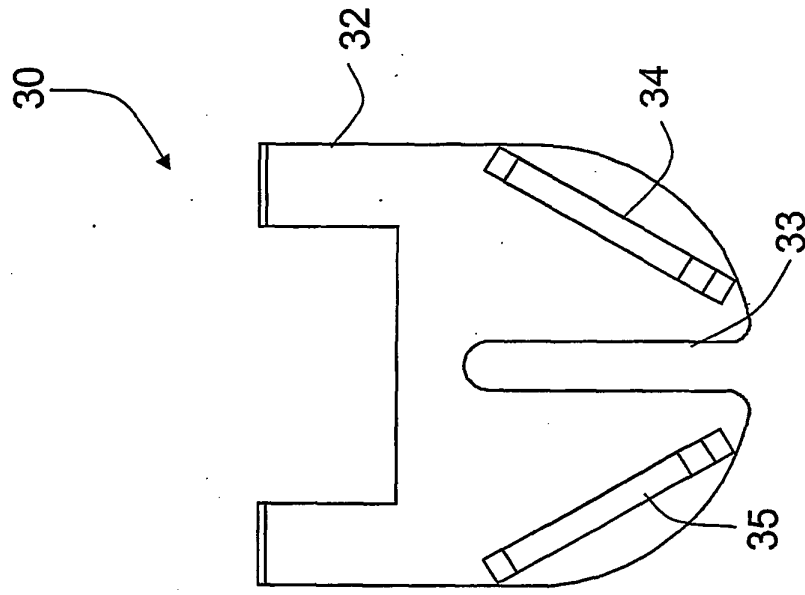

Fig.7

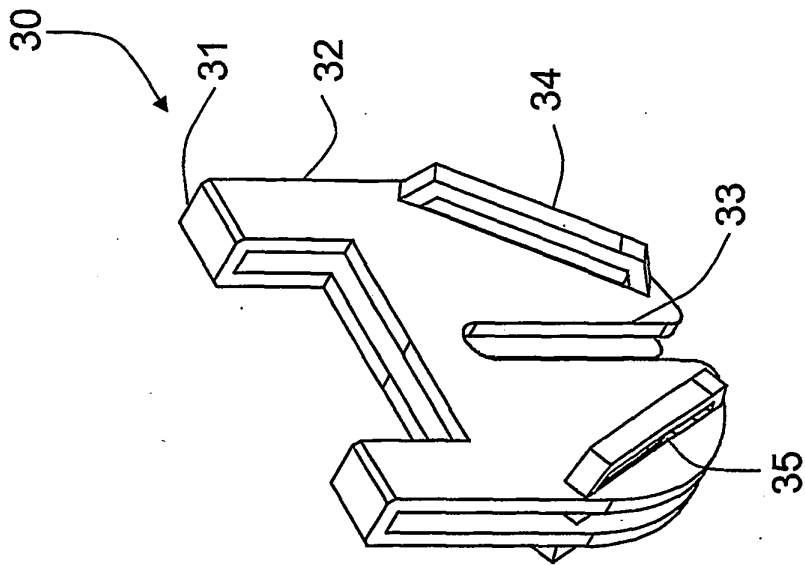

Fig.6

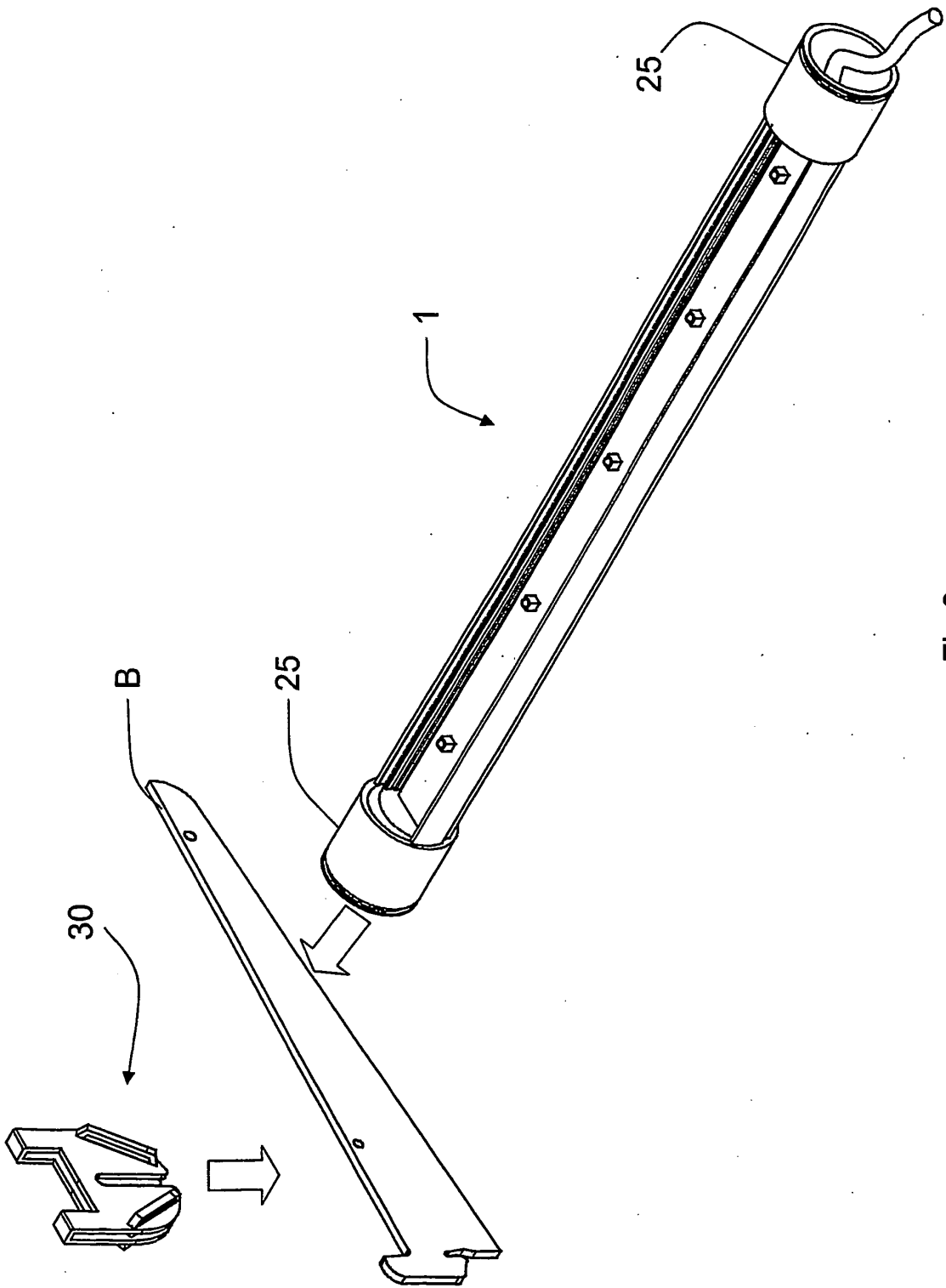

Fig.9

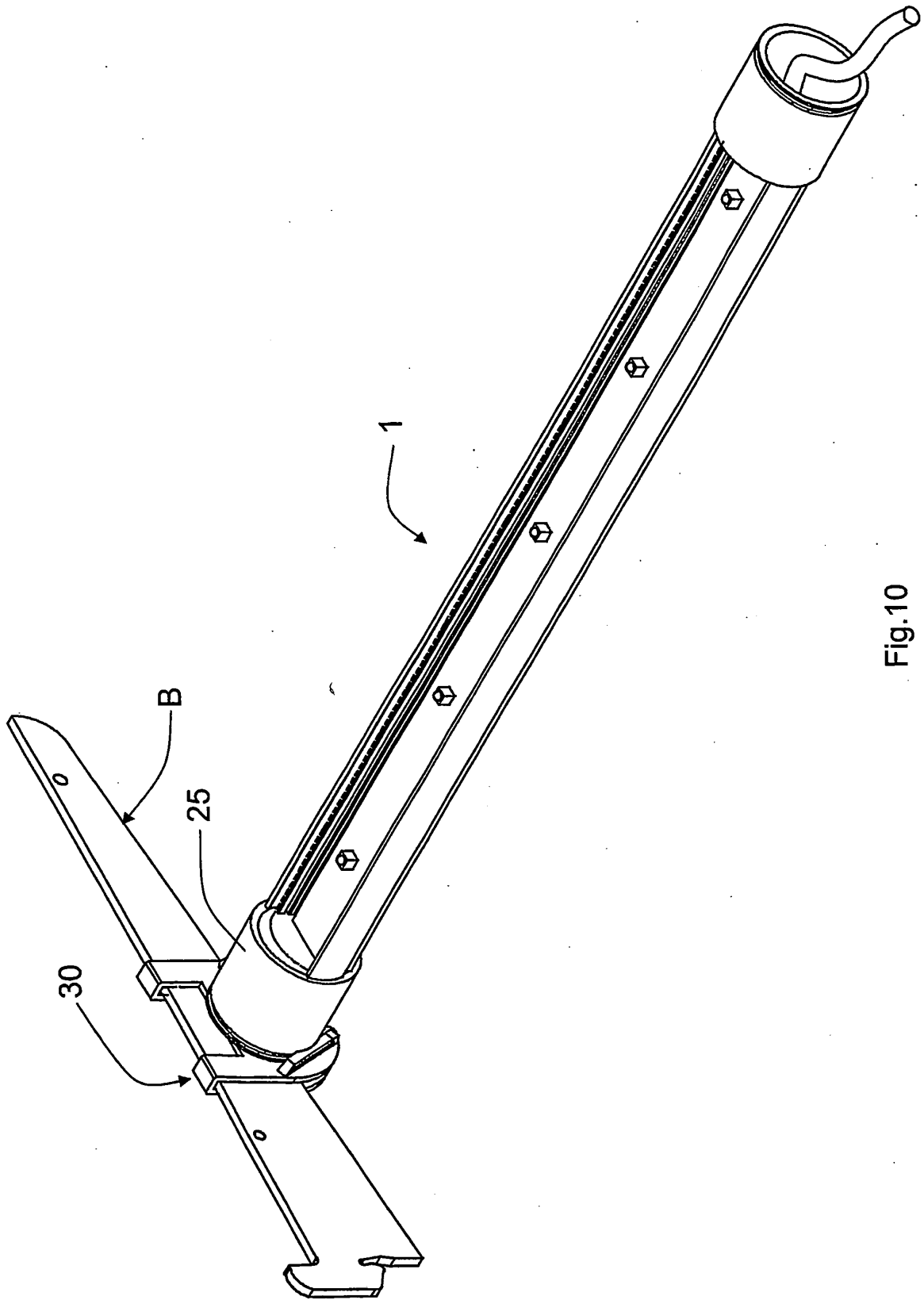

Fig.10

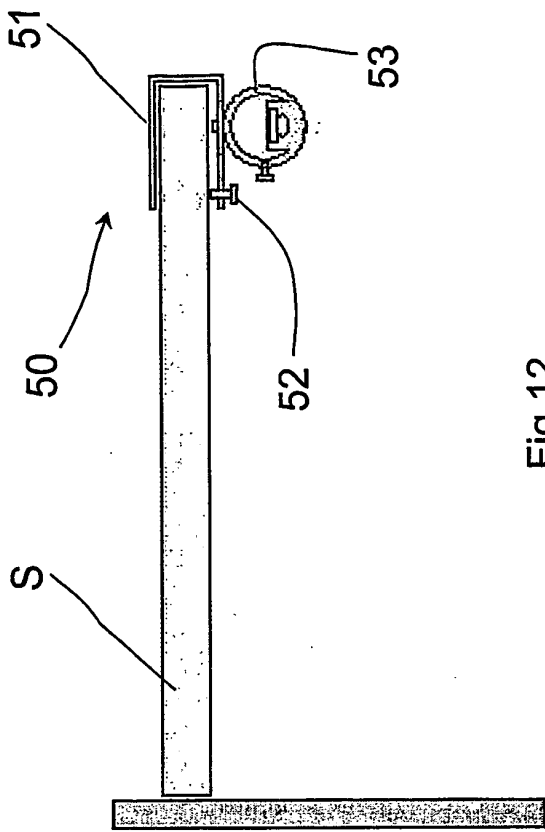

Fig.12

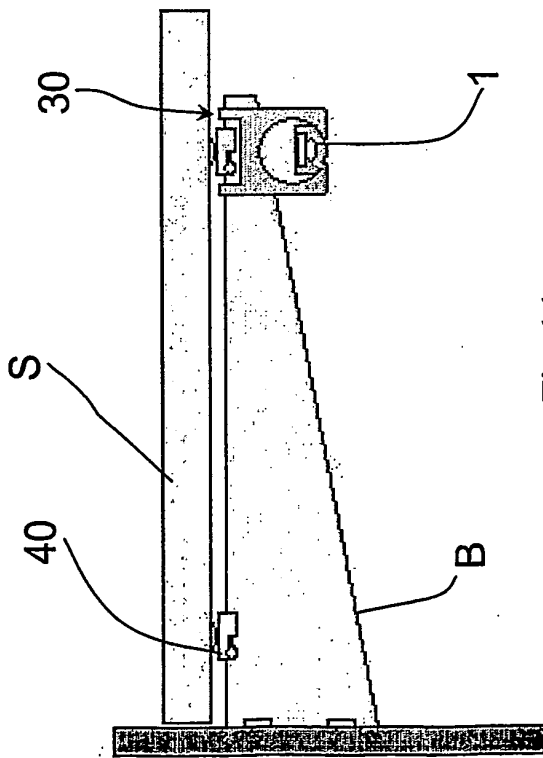

Fig.11

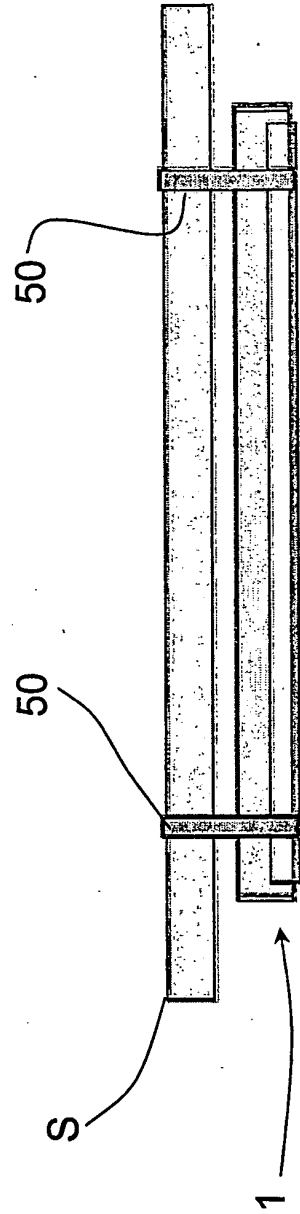

Fig.13

**REFERENCES CITED IN THE DESCRIPTION**

*This list of references cited by the applicant is for the reader's convenience only. It does not form part of the European patent document. Even though great care has been taken in compiling the references, errors or omissions cannot be excluded and the EPO disclaims all liability in this regard.*

**Patent documents cited in the description**

- US 20030137828 A [0001]