



(11) **EP 1 950 602 B9**

(12) **CORRECTED EUROPEAN PATENT SPECIFICATION**

- (15) Correction information:  
**Corrected version no 1 (W1 B1)**  
**Corrections, see**  
**Description Paragraph(s) 6, 13, 22, 29, 30, 36**  
**Claims DE 1**  
**Claims EN 1-4**
- (51) Int Cl.:  
**G02F 1/03 (2006.01)**
- (86) International application number:  
**PCT/JP2006/322533**
- (87) International publication number:  
**WO 2007/058137 (24.05.2007 Gazette 2007/21)**
- (48) Corrigendum issued on:  
**22.05.2013 Bulletin 2013/21**
- (45) Date of publication and mention of the grant of the patent:  
**12.09.2012 Bulletin 2012/37**
- (21) Application number: **06832545.5**
- (22) Date of filing: **13.11.2006**

(54) **Suppression of Microwave Radiation Mode Effects in an Electro-optic Optical Modulator**

Unterdrückung von Mikrowellenstrahlungsmodeneffekten in einem electro-optischen Modulator

Suppression des effets dus aux modes de rayonnement micro-ondes dans un modulateur optique de type électro-optique

- (84) Designated Contracting States:  
**DE FR GB IT**
- (30) Priority: **16.11.2005 JP 2005331954**
- (43) Date of publication of application:  
**30.07.2008 Bulletin 2008/31**
- (60) Divisional application:  
**11188477.1 / 2 442 173**
- (73) Proprietor: **SUMITOMO OSAKA CEMENT CO., LTD.**  
**Tokyo 102-8465 (JP)**
- (72) Inventors:  
  - **SHIMIZU, Ryo**  
**Tokyo 102-8465 (JP)**
  - **FUJITA, Takahisa**  
**Tokyo 102-8465 (JP)**
- **SUGAMATA, Toru**  
**Tokyo 102-8465 (JP)**
- (74) Representative: **Staudt, Hans-Peter et al**  
**Bittner & Partner**  
**Intellectual Property Division**  
**Donaustrasse 7**  
**85049 Ingolstadt (DE)**
- (56) References cited:  
**EP-A1- 1 953 584 JP-A- 08 288 701**  
**JP-A- 2004 093 606 US-A1- 2004 264 835**  
**US-B2- 6 741 379**
- **GOPALAKRISHNAN G K ET AL: "Electrical loss mechanisms in travelling wave LiNbO3 optical modulators", ELECTRONICS LETTERS UK, vol. 28, no. 2, 16 January 1992 (1992-01-16), pages 207-209, XP002609103, ISSN: 0013-5194**

Note: Within nine months of the publication of the mention of the grant of the European patent in the European Patent Bulletin, any person may give notice to the European Patent Office of opposition to that patent, in accordance with the Implementing Regulations. Notice of opposition shall not be deemed to have been filed until the opposition fee has been paid. (Art. 99(1) European Patent Convention).

**EP 1 950 602 B9**

## Description

[Technical Field]

**[0001]** The present invention relates to an optical modulator, and more particularly, to an optical modulator having a connection substrate arranged outside an optical modulation element or a termination substrate.

[Background Art]

**[0002]** In general, waveguide type optical modulators in which an optical waveguide or a modulating electrode is formed onto a substrate having an electro-optic effect are widely used in optical communication fields or optical measurement fields. At the request of improvement of high-speed, high-capacity communication or optical measurement precision in this optical modulator, the development of an optical modulator stably operable even in a high-frequency band is required. Recently, optical modulators of more than several tens GHz have also been implemented.

**[0003]** When the optical modulator operates in the high-frequency band, a jitter value of an eye pattern is apt to be large in an optical output waveform from the optical modulator. There occurs the degradation of modulation properties including the degradation of waveform quality of an optical output signal or the reduction of an optical transmission distance.

In a result of keen research by the inventors, it has been found that noise included in a microwave signal operating the optical modulator is one of factors causing the jitter value to be large as described below.

**[0004]** An example of the optical modulator is shown in Fig. 1. An optical modulation element 1 of Fig. 1(a) is formed with an optical waveguide (not shown), a modulating electrode, and the like on a substrate having the electro-optic effect such as  $\text{LiNbO}_3$ . The modulating electrode is constructed with a signal electrode 2, a ground electrode (not shown), and the like. The optical modulation element 1 is connected to an optical fiber 3 for receiving and emitting an optical wave.

A connection substrate 4 having an amplifier 8 and the like and a termination substrate 5 having a termination device 9 and the like are arranged around the optical modulation element 1. Along with the optical modulation element 1, the connection substrate 4 or the termination substrate 5 is accommodated within a case 10 and forms an optical modulator module.

For reference, an example of the optical modulator module using the connection substrate is disclosed in Patent Document 1.

[Patent Document 1] JP-A-2003-233043 (or US 6 741 379.) The features of the preamble of claim 1 are known from document.

**[0005]** A method of operating an optical modulator will

be described. A microwave signal generated from a modulation signal source 6 is introduced into a GPO connector 7 corresponding to an input terminal of a case 10 and is transmitted from the associated connector to a signal input terminal 11 of a connection substrate 4 as shown in Fig. 1B.

In the connection substrate 4, the microwave signal is output to a signal output terminal 12 through an amplifier 8 or a functional element (not shown) for converting the microwave signal into various states.

**[0006]** Wire bonding is done between the signal output terminal 12 of the connection substrate and an electrode pad of the signal electrode 2 of an optical modulation element. The microwave signal output from the connection substrate 4 is continuously transmitted to the signal electrode 2. According to the microwave signal transmitted to the signal electrode 2, the optical wave propagating within the optical waveguide of the optical modulation element is optically modulated.

**[0007]** An additional electrode pad is provided on a terminal of the signal electrode 2. Similarly, wire bonding is done between the electrode pad and a signal introduction terminal 14 of the termination substrate as shown in Fig. 1C. Thus, the microwave signal is additionally transmitted from the signal electrode 2 to the termination substrate 5, and is absorbed by a termination device 9 provided within the termination substrate.

**[0008]** However, the inventors have found that a radiation mode 13 of a microwave is generated from a microwave signal input to the signal input terminal 11 in the connection substrate 4 as shown in Fig. 1B and the radiation mode 13 propagates through the connection substrate and is recombined with the microwave signal propagating through a signal line in the signal output terminal 12. The recombined radiation mode serves as noise in a modulation signal. This noise propagates through the signal electrode 2 of the optical modulation element, thereby degrading modulation properties of the optical modulator.

**[0009]** In the termination substrate 5 as shown in Fig. 1C, part of a microwave signal introduced into the termination device 9 is reflected by the termination device and generates a radiation mode 15 of the microwave. The radiation mode 15 is recombined with the signal introduction terminal 14 of the signal propagating through the termination substrate, and is propagated to the signal electrode 2, so that the microwave travels in a direction reverse to the conventional propagation direction. This radiation mode 15 also serves as noise in a modulation signal.

**[0010]** In the connection substrate 4, a radiation mode (not shown) of the microwave reflected by the signal output terminal 12 is generated. The microwave propagating through the signal electrode 2 in the reverse direction generates a radiation mode (not shown) in the signal output terminal 12. These radiation modes are recombined with the signal input terminal 11 of the signal propagating through the connection substrate and flow backward to

the modulation signal source 6, thereby causing the operation of the optical signal source to be unstable. US 6 741 379 B2 discloses a corresponding optical modulator.

[Disclosure of the Invention]

[Problems to be Solved by the Invention]

**[0011]** The invention has been made to solve the above-mentioned problems, and it is an object of the invention to provide an optical modulator that suppresses a radiation mode of a microwave generated in a connection substrate or a termination substrate from entering a signal electrode of the optical modulator and suppresses modulation properties from being degraded. These problems are solved by an optical modulator according to claim 1. Referred embodiments are defined in the subclaims.

[Means for Solving the Problems]

**[0012]** According to a first aspect of the invention, an optical modulator includes an optical modulation element having a substrate with an electro-optic effect, an optical waveguide formed on the substrate, and a modulating electrode for modulating light passing through the optical waveguide; and a connection substrate, arranged outside the substrate, for supplying the optical modulation element with a microwave signal operating the optical modulation element, wherein a signal input terminal and a signal output terminal are formed on the connection substrate, and a recombination suppression unit, recited as "recombination suppression means" in the claims, that suppresses a radiation mode of the microwave signal input to the signal input terminal from being recombined with the signal output terminal is provided on the connection substrate.

**[0013]** In an arrangement not part of the invention, the recombination suppression unit is arranged so that the signal output terminal is not located on a path through which the radiation mode of the microwave signal propagates.

**[0014]** In the optical modulator according to the first aspect, the recombination suppression unit is formed in front of and next to the signal output terminal and is a unit that shields from the radiation mode of the microwave signal or removes the radiation mode of the microwave signal to the outside of the connection substrate.

**[0015]** According to a further aspect of the invention, a functional element for converting the microwave signal into various states is arranged on the connection substrate.

In the invention, "the functional element for converting the microwave signal into various states" is arranged on the connection substrate, and refers to an electrical circuit element having a function for converting a microwave signal state into a specific state in signal amplification/

attenuation, phase adjustment, signal division or combination, or the like according to the microwave signal.

[Effects of the Invention]

5

**[0016]** According to a first aspect of the invention, since an optical modulator includes an optical modulation element having a substrate with an electro-optic effect, an optical waveguide formed on the substrate, and a modulating electrode for modulating light passing through the optical waveguide; and a connection substrate, arranged outside the substrate, for supplying the optical modulation element with a microwave signal operating the optical modulation element, wherein a signal input terminal and a signal output terminal are formed on the connection substrate, and a recombination suppression unit that suppresses a radiation mode of the microwave signal input to the signal input terminal from being recombined with the signal output terminal is provided on the connection substrate, a defect in which the radiation mode is recombined with the signal output terminal and enters a signal electrode can be suppressed and the degradation of modulation properties due to the radiation mode of the microwave can be suppressed.

10

15

20

25

**[0017]** According to an arrangement not part of the invention, since the recombination suppression unit is arranged so that the signal output terminal is not located on a path through which the radiation mode of the microwave signal propagates, a defect due to the radiation mode can be effectively addressed in a simple and convenient configuration in which an arrangement of the signal input terminal generating the radiation mode and the signal output terminal recombined with the radiation mode is adjusted.

30

35

**[0018]** Since the recombination suppression means in the invention is formed in front of and next to the signal output terminal and is a means that shields from the radiation mode of the microwave signal or removes the radiation mode of the microwave signal to the outside of the connection substrate, a recombination of the radiation mode at the signal output terminal can be effectively suppressed by forming the shielding or removal means in the connection substrate.

40

45

**[0019]** According to a further aspect of the invention, since a functional element for converting the microwave signal into various states is arranged on the connection substrate, a defect due to the radiation mode can be addressed also in various connection substrates.

50

[Brief Description of the Drawings]

**[0020]**

55

Fig. 1 is a schematic diagram of a conventional optical modulator.

Fig. 2 is a schematic diagram of a further optical modulator, which is not part of the invention.

Fig. 3 is a diagram showing examples in which a

plurality of signal input terminals or a plurality of signal output terminals are provided in the optical modulator of figure 2.

Fig. 4 is a diagram showing examples of using a shielding body in the optical modulator in accordance with the invention.

Fig. 5 is a diagram showing examples of using a radiation mode discharging unit in the optical modulator in accordance with the invention.

Fig. 6 is a diagram showing examples of using a through hole as the radiation mode discharging unit in the optical modulator in accordance with the invention.

[Reference Numerals]

**[0021]**

1: OPTICAL MODULATION ELEMENT  
 2: SIGNAL ELECTRODE  
 3: OPTICAL FIBER  
 4, 20, 30, 40, 50, 60, 70: CONNECTION SUBSTRATE  
 5, 21: TERMINATION SUBSTRATE  
 6: MODULATION SIGNAL SOURCE  
 7: CONNECTOR  
 8, 52, 63, 72: AMPLIFIER  
 9: TERMINATION DEVICE  
 10: CASE  
 11, 22, 31, 41, 42, 51, 61, 71: SIGNAL INPUT TERMINAL  
 12, 23, 33, 34, 44, 45, 54, 65, 74: SIGNAL OUTPUT TERMINAL  
 13, 15, 24, 26, 35, 46, 47, 56, 67, 76: MICROWAVE RADIATION MODE  
 14, 25: SIGNAL INTRODUCTION TERMINAL  
 53, 62, 64, 73: SIGNAL LINE  
 55: SHIELDING BODY  
 66: CAVITY (CONCAVE PORTION)  
 75: THROUGH HOLE

[Best Mode for Carrying Out the Invention]

**[0022]** Hereinafter, exemplary embodiments of the invention will be described.

Fig. 2 is a schematic diagram of an optical modulator, which is not according to the invention.

In Fig. 2, portions having the same reference numerals as those of Fig. 1 have configurations similar thereto. In this modulator, if a substrate having an electro-optic effect, an optical waveguide formed onto the substrate, and a modulating electrode for modulating light passing through the optical waveguide are provided for an optical modulation element 1, they are not specifically limited in terms of materials or other structures. For example, the substrate having the electro-optic effect can use lithium-niobate, lithium tantalate, Lead Lanthanum Zirconate Titanate (PLZT), and a quartz-based material. The optical

waveguide of the substrate can be formed by diffusing Ti or the like on the substrate surface in a thermal diffusion method, a proton exchange method, or the like. A signal electrode or a ground electrode constructing the modulating electrode can be formed by an electrode pattern of Ti/Au and can be formed by a gold plating method or the like. If needed, a buffer layer of a dielectric substance of SiO<sub>2</sub> or the like can be provided on the substrate surface after the optical waveguide is formed.

**[0023]** A feature of the modulator shown in Fig. 2 is that a microwave radiation mode can be effectively suppressed from being recombined with a signal line by adjusting an arrangement of the input and output terminals and the like within the substrate as shown in Fig. 2(b) or 2(c) in a connection substrate 20 and a termination substrate 21.

**[0024]** In the connection substrate 20, a radiation mode 24 of the microwave signal generated from a signal input terminal 22 is radiated at an angle of more than about one degree with respect to the signal line and almost propagates through the connection substrate in a direction as indicated by a dashed dotted line A. Thus, the radiation mode 24 can be suppressed from being recombined with a signal output portion 23 by arranging a signal output portion 23 in a position away from the dashed dotted line A.

**[0025]** Similarly, in the termination substrate 21, a radiation mode 26 of the microwave reflected from a termination device 9 almost propagates through the termination substrate in a direction as indicated by a dashed dotted line B. Thus, the radiation mode 26 can be suppressed from being recombined with a signal introduction terminal 25 by arranging the signal introduction terminal 25 away from the dashed dotted line B.

**[0026]** By adopting the configuration as shown in Fig. 2 (b) also for a radiation mode (not shown) of the microwave generated from the signal output terminal 23 as described above in the connection substrate 20, the radiation mode can be suppressed from being recombined with the signal input terminal 22 and the influence to a modulation signal source can be mitigated.

**[0027]** In Fig. 2, an example is shown in which one signal input terminal 22 and one signal output terminal 23 are located in the connection substrate 20, but the optical modulator can for example comprise a plurality of signal output terminals included in a connection substrate 30 as shown in Fig. 3 (a). Alternatively, a plurality of signal input terminals and a plurality of signal output terminals can be included in a connection substrate 40 as shown in Fig. 3(b).

**[0028]** In the case of Fig. 3 (a), signal output terminals 33 and 34 are arranged in positions away from a propagation direction (as indicated by a dashed dotted line C) for a radiation mode 35 of a microwave signal radiated from a signal input terminal 31.

**[0029]** By arranging signal output terminals 44 and 45 in positions away from dashed dotted lines D and E for a radiation mode 46 of a microwave signal radiated from

a signal input terminal 41 and a radiation mode 47 of a microwave signal radiated from another signal input terminal 42 in the case of Fig. 3 (b), the radiation modes can be suppressed from being recombined with the signal output terminals. Reference numeral 43 refers to a compound functional element in which a combiner or divider and the like are combined.

The connection substrate has been described with reference to Fig. 3. Similarly, it is also possible to construct a termination substrate in which multiple signal introduction terminals or multiple termination devices are used.

**[0030]** In Figs. 2 and 3, a method of adjusting an arrangement of the input and output terminals and the like has been illustrated as a recombination suppression unit for suppressing a recombination of the microwave radiation mode. As shown in Fig. 4 or 5 according to the invention, there a means is used for shielding from the microwave radiation mode or discharging (i.e. removing) the microwave radiation mode to the outside of the termination substrate.

**[0031]** Fig. 4 shows examples of a connection substrate 50 having an amplifier 52. A configuration is made so that a radiation mode 56 of a microwave radiated from a signal input terminal 51 is shielded using a shielding body 55 and is not incident into a signal output portion 54. Fig. 4(b) shows a sectional view taken along a dashed dotted line F of Fig. 4 (a). Reference numeral 53 refers to a signal line.

**[0032]** Preferably, a low dielectric loss material such as aluminum, oxide aluminum, or the like can be used as a substrate material constructing a connection substrate or a termination substrate. Preferably, a conductive metal material such as Au, Al, or the like can be used as the shielding body.

A method of assembling the shielding body in a substrate can adopt a method of forming a concave portion to the substrate in a cutting process or the like, a method of inserting a small piece made of a shielding material into the concave portion, or the like.

**[0033]** Fig. 5 shows examples of a connection substrate 60 having an amplifier 63. A configuration is made so that a radiation mode 67 of a microwave radiated from a signal input terminal 61 is discharged outside the connection substrate 60 using a cavity (or concave portion) 66 and is not incident into a signal output portion 65. Fig. 5 (b) shows a sectional view taken along a dashed dotted line G of Fig. 5(a). Reference numerals 62 and 64 refer to signal lines.

**[0034]** As shown in Fig. 6, a radiation mode 76 of a microwave radiated from a signal input terminal 71 can be discharged outside a connection substrate 70 using a through hole 75 passing through the connection substrate 70 in the connection substrate 70 having an amplifier 72. This configuration is made so that the radiation mode 76 of the microwave is not incident into a signal output portion 74. Fig. 6 (b) shows a sectional view taken along a dashed dotted line H of Fig. 6(a). Reference numeral 73 refers to a signal line.

**[0035]** The technique of shielding or discharging the radiation mode as shown in Figs. 4 to 6 can be applied to a connection substrate or a termination substrate having other functional elements. If needed, various types of techniques as described above can be also combined and used.

[Industrial Applicability]

**[0036]** According to the invention as described above, an optical modulator can be provided which suppresses a radiation mode of a microwave generated in a connection substrate or a termination substrate from entering a signal electrode of the optical modulator and suppresses the degradation of the modulation properties of the modulator.

## Claims

1. An optical modulator comprising:

an optical modulation element (1) having a substrate with an electro-optic effect, an optical waveguide formed on the substrate, and a modulating electrode for modulating light passing through the optical waveguide;  
 a connection substrate (50, 60, 70), arranged outside the optical modulation element (1) and adapted to supply the optical modulation element (1) with a microwave signal for operating the optical modulation element (1), wherein a signal input terminal (51, 61, 71) and a signal output terminal (54, 65, 74) are arranged on the connection substrate (50, 60, 70); and  
 a recombination suppression means, which suppresses the recombination at the signal output terminal (54, 65, 74) of a microwave substrate radiation mode (56, 67, 76) generated from the microwave signal input to the signal input terminal (51,61,71) with the microwave signal itself propagating along a signal line (53,64,73), said signal line being arranged between the signal input terminal (51,61,71) and the signal output terminal (54,65,73), is provided on the connection substrate (50, 60, 70), **characterized in that** the recombination suppression means is arranged in front of and next to the signal output terminal (54, 65, 74) and is a means that shields the signal output terminal (54,65,74) from the radiation mode of the microwave signal or removes the radiation mode of the microwave signal to the outside of the connection substrate.

2. The optical modulator according to claim 1, wherein said recombination suppression means is a means that shields from the radiation mode of the

microwave signal and consists of a concave portion (66) formed in the connection substrate (50, 60, 70) in front of and next to the signal output terminal (23, 33, 34, 44, 45, 54, 65, 74) and a shielding material inserted into the concave portion (66).

3. The optical modulator according to claim 1, wherein said recombination suppression means is a means that removes the radiation mode of the microwave signal to the outside the connection substrate (50, 60, 70) and consists of a cavity (66) or a through hole (75) formed in the connection substrate (50, 60, 70) in front of and next to the signal output terminal (54, 65, 74).
4. The optical modulator according to any of claims 1 to 3, wherein an electrical circuit element for converting the microwave signal is arranged on the connection substrate (50, 60, 70).

#### Patentansprüche

1. Optischer Modulator, umfassend:

ein optisches Modulationselement (1) mit einem Substrat mit einem elektro-optischen Effekt, einem optischen Wellenleiter, der auf dem Substrat ausgebildet ist, und einer Modulationselektrode zum Modulieren von Licht, das durch den optischen Wellenleiter hindurchtritt;

ein Verbindungssubstrat (50, 60, 70), das außerhalb des optischen Modulationselements (1) angeordnet ist und dazu ausgelegt ist, dem optischen Modulationselement (1) ein Mikrowellensignal zuzuführen zum Betätigen des optischen Modulationselements (1), wobei ein Signaleingangsanschluss (51, 61, 71) und ein Signalausgangsanschluss (54, 65, 74) auf dem Verbindungssubstrat (50, 60, 70) angeordnet sind; und

eine Rekombinationsunterdrückungseinrichtung, die die Rekombination an dem Signalausgangsanschluss (54, 65, 74) einer Mikrowellensubstratradiation-Mode (56, 67, 76), der erzeugt wird von dem Mikrowellensignaleingang in den Signaleingangsanschluss (51, 61, 71), unterdrückt, wobei das Mikrowellensignal selbst längs einer Signalleitung (53, 64, 73) fortschreitet, wobei die Signalleitung angeordnet ist zwischen dem Signaleingangsanschluss (51, 61, 71) und dem Signalausgangsanschluss (54, 65, 73), und vorgesehen ist auf dem Verbindungssubstrat (50, 60, 70),

**dadurch gekennzeichnet, dass**

die Rekombinationsunterdrückungseinrichtung vor und in der Nähe des Signalausgangs-

anschlusses (54, 65, 74) angeordnet ist und eine Einrichtung ist, die den Signalausgangsanschluss (54, 65, 74) von der Radiation-Mode des Mikrowellensignals abschirmt oder die Radiation-Mode des Mikrowellensignals zu der Außenseite des Verbindungssubstrats entfernt.

2. Optischer Modulator nach Anspruch 1, wobei die Rekombinationsunterdrückungseinrichtung eine Einrichtung ist, die von der Radiation-Mode des Mikrowellensignals abschirmt und die besteht aus einem konkaven Abschnitt (66), der in dem Verbindungssubstrat (50, 60, 70) ausgebildet ist vor und in der Nähe des Signalausgangsanschlusses (23, 33, 34, 44, 45, 54, 65, 74) und einem Abschirmmaterial, das in den konkaven Bereich (66) eingefügt ist.
3. Optischer Modulator nach Anspruch 1, wobei die Rekombinationsunterdrückungseinrichtung eine Einrichtung ist, die die Radiation-Mode des Mikrowellensignals zu der Außenseite des Verbindungssubstrats (50, 60, 70) entfernt und besteht aus einer Vertiefung (66) oder einem Durchgangsloch (75), das in dem Verbindungssubstrat (50, 60, 70) ausgebildet ist vor und in der Nähe des Signalausgangsanschlusses (54, 65, 74).
4. Optischer Modulator nach einem der Ansprüche 1 bis 3, wobei ein elektrisches Schaltungselement zum Konvertieren des Mikrowellensignals auf dem Verbindungssubstrat (50, 60, 70) angeordnet ist.

#### Revendications

1. Modulateur optique comprenant:

un élément de modulation optique (1) ayant un substrat avec un effet électro-optique, un guide d'ondes optique formé sur le substrat, et une électrode modulante destinée à moduler la lumière passant à travers le guide d'ondes optique;

un substrat de connexion (50, 60, 70), agencé à l'extérieur de l'élément de modulation optique (1), et adapté pour fournir à l'élément de modulation optique (1) un signal hyperfréquences pour actionner l'élément de modulation optique (1), dans lequel une borne d'entrée de signal (51, 61, 71) et une borne de sortie de signal (54, 65, 74) sont agencées sur le substrat de connexion (50, 60, 70); et

un moyen de suppression de recombinaison, qui supprime la recombinaison au niveau de la borne de sortie de signal (54, 65, 74) d'un mode de rayonnement de substrat hyperfréquences (56, 67, 76) généré à partir d'entrée du signal hyperfréquences appliqué à la borne d'entrée de

signal (51, 61, 71), avec le signal hyperfréquences lui-même qui se propage le long d'une ligne de signal (53, 64, 73), ladite ligne de signal étant agencée entre la borne d'entrée de signal (51, 61, 71) et la borne de sortie de signal (54, 65, 73), est prévu sur le substrat de connexion (50, 60, 70),

**caractérisé en ce que**

le moyen de suppression de recombinaison est agencé en face et à côté de la borne de sortie de signal (54, 65, 74), et est un moyen qui protège la borne de sortie de signal (54, 65, 74) du mode de rayonnement du signal hyperfréquences ou supprime le mode de rayonnement du signal hyperfréquences vers l'extérieur du substrat de connexion.

2. Modulateur optique selon la revendication 1, dans lequel ledit moyen de suppression de recombinaison est un moyen qui protège du mode de rayonnement du signal hyperfréquences et est constitué d'une partie concave (66) formée dans le substrat de connexion (50, 60, 70) en face et à côté de la borne de sortie de signal (23, 33, 34, 44, 45, 54, 65, 74), et d'un matériau de protection inséré dans la partie concave (66).
3. Modulateur optique selon la revendication 1, dans lequel ledit moyen de suppression de recombinaison est un moyen qui supprime le mode de rayonnement du signal hyperfréquences vers l'extérieur du substrat de connexion (50, 60, 70), et est constitué d'une cavité (66) ou d'un trou traversant (75) formé dans le substrat de connexion (50, 60, 70) en face et à côté de la borne de sortie de signal (54, 65, 74).
4. Modulateur optique selon l'une quelconque des revendications 1 à 3, dans lequel un élément de circuit électrique destiné à convertir le signal hyperfréquences est agencé sur le substrat de connexion (50, 60, 70).

45

50

55

[Fig. 1]

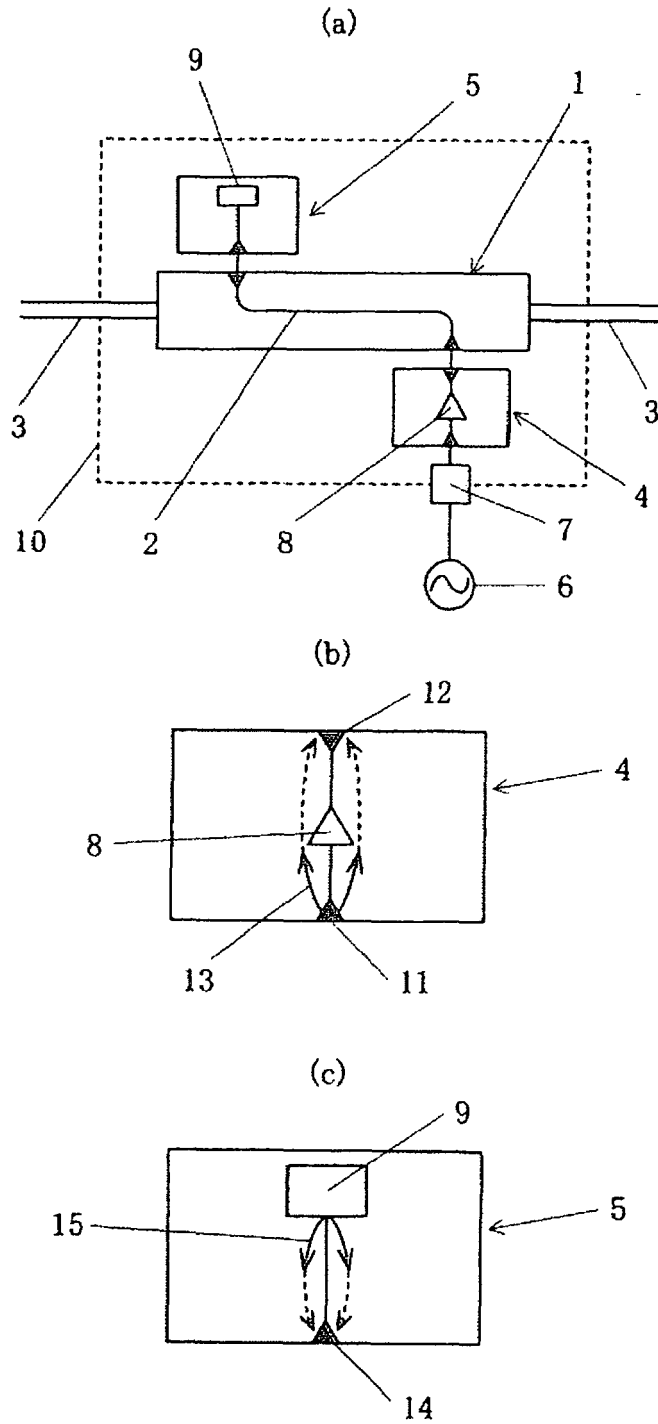

[Fig. 2]

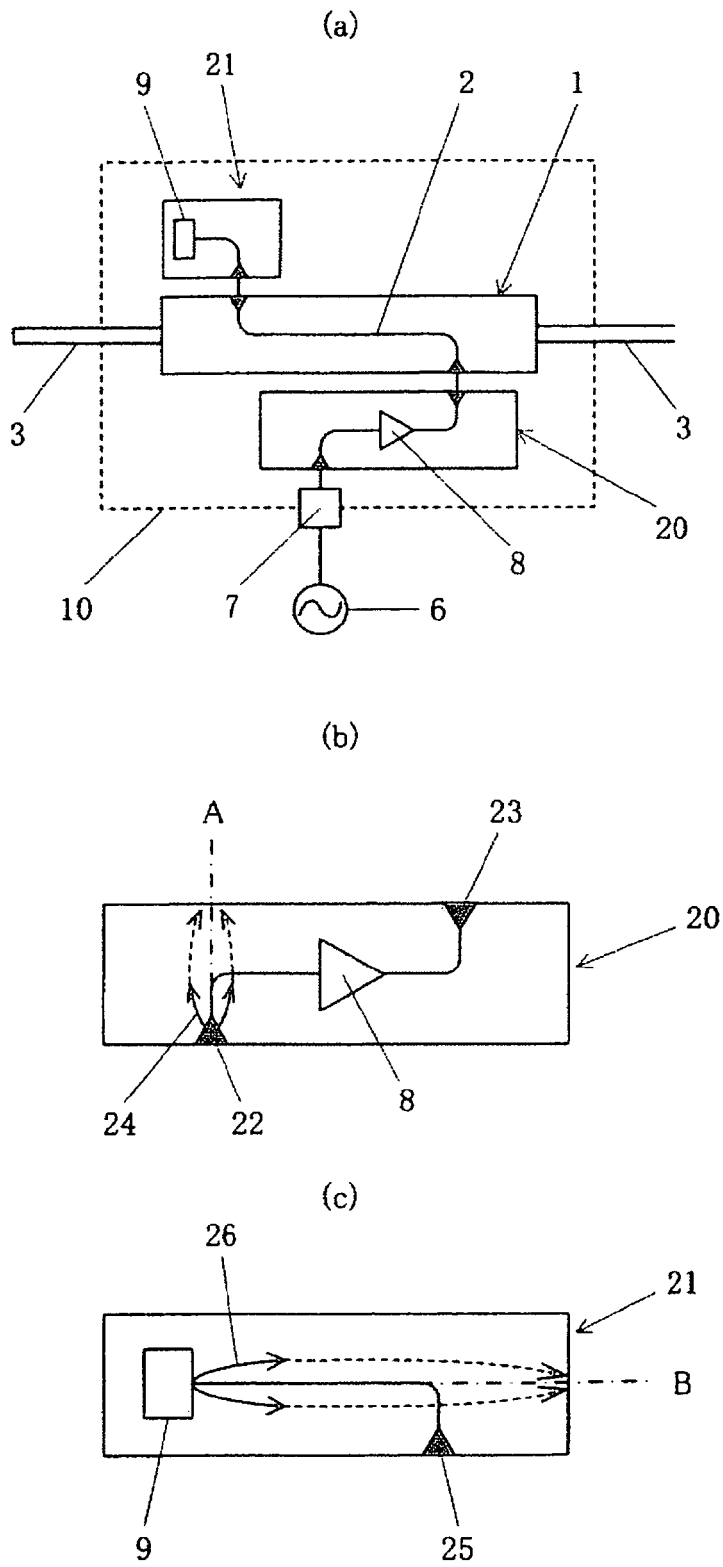

[Fig. 3]

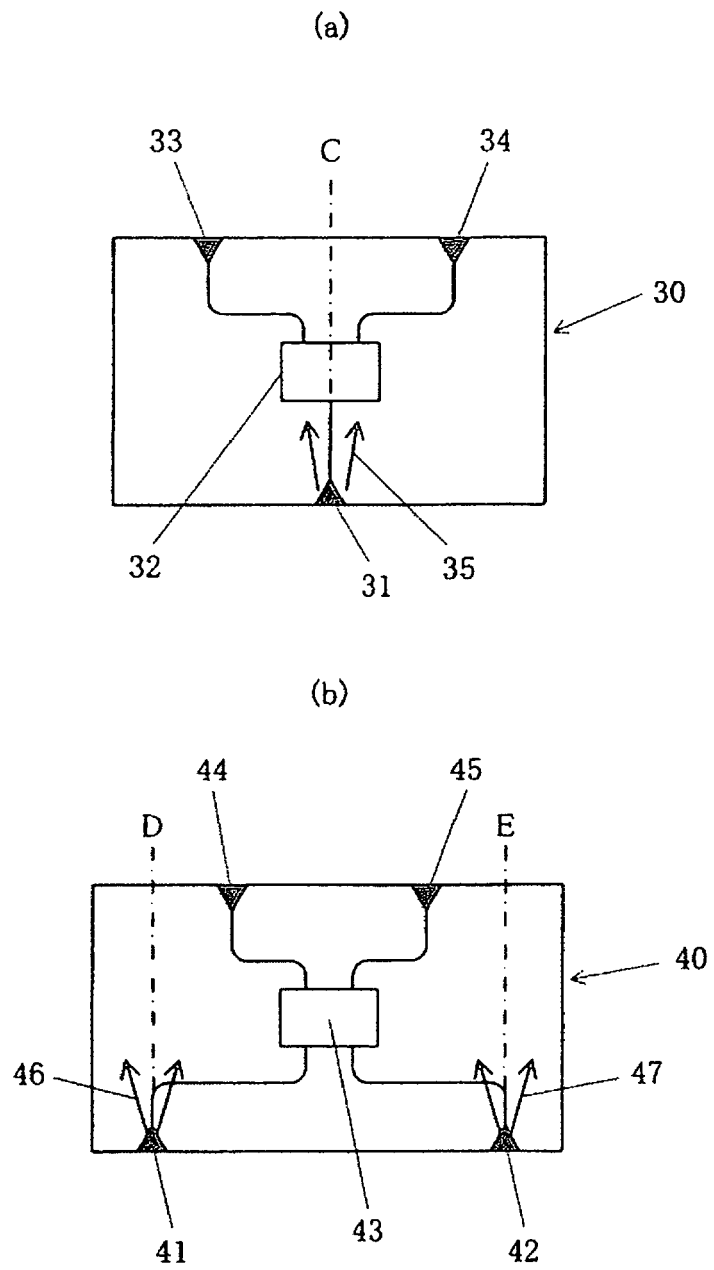

[Fig. 4]

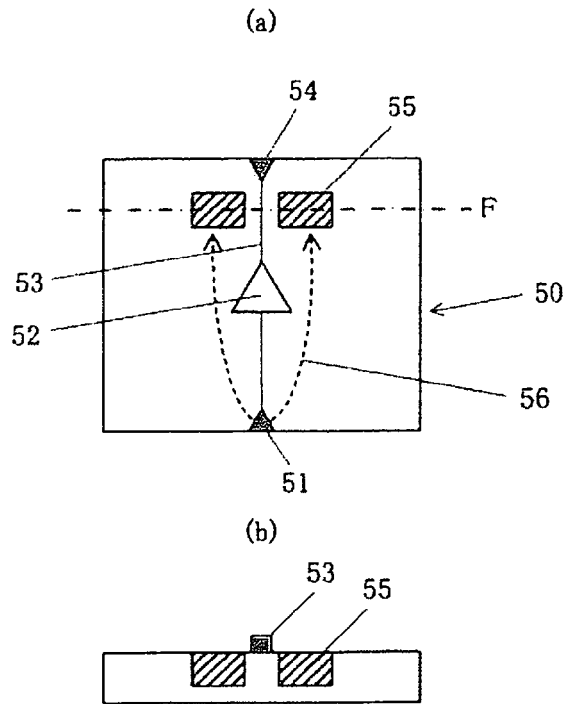

[Fig. 5]

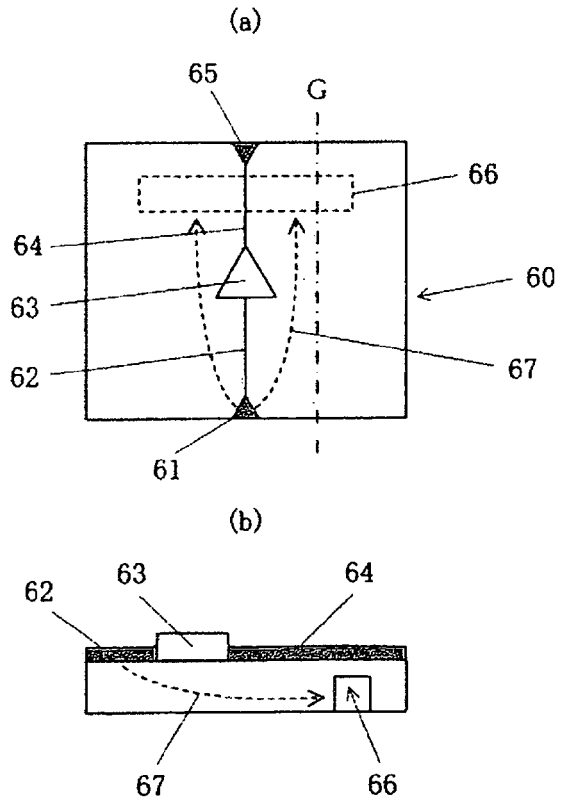

[Fig. 6]

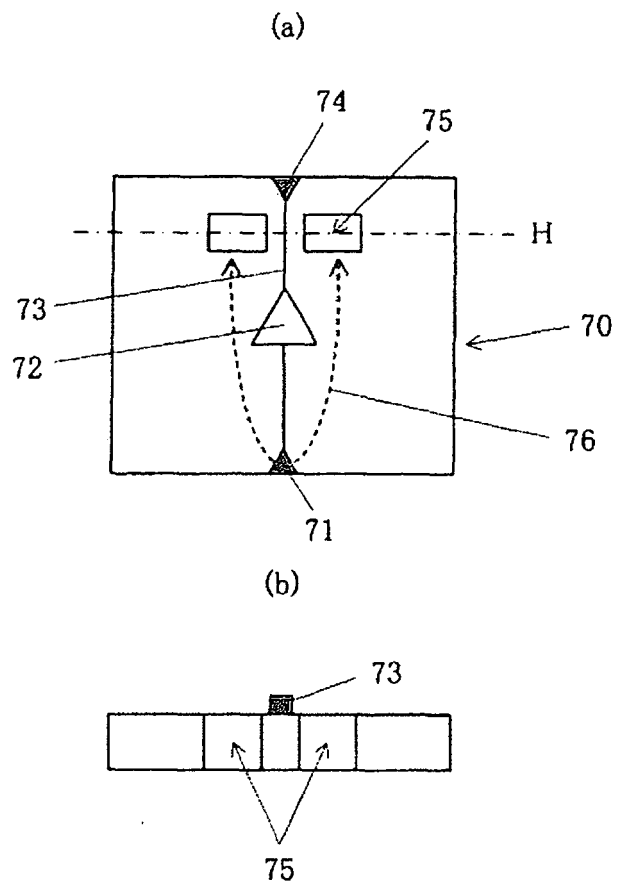

**REFERENCES CITED IN THE DESCRIPTION**

*This list of references cited by the applicant is for the reader's convenience only. It does not form part of the European patent document. Even though great care has been taken in compiling the references, errors or omissions cannot be excluded and the EPO disclaims all liability in this regard.*

**Patent documents cited in the description**

- JP 2003233043 A [0004]
- US 6741379 B [0004]
- US 6741379 B2 [0010]