

(19)



(11)

**EP 1 958 541 A3**

(12)

**EUROPEAN PATENT APPLICATION**

(88) Date of publication A3:  
**25.11.2009 Bulletin 2009/48**

(51) Int Cl.:  
**A47B 57/42 (2006.01)**

(43) Date of publication A2:  
**20.08.2008 Bulletin 2008/34**

(21) Application number: **08001499.6**

(22) Date of filing: **28.01.2008**

(84) Designated Contracting States:  
**AT BE BG CH CY CZ DE DK EE ES FI FR GB GR  
 HR HU IE IS IT LI LT LU LV MC MT NL NO PL PT  
 RO SE SI SK TR**  
 Designated Extension States:  
**AL BA MK RS**

(71) Applicant: **Wireland S.A.**  
**77-100 Bytów (PL)**

(72) Inventor: **Chojnicki, Adam**  
**77-100 Bytów (PL)**

(74) Representative: **Niburska, Danuta**  
**Al. 3 Maja 68 B**  
**PL-76-200 Slupsk (PL)**

(30) Priority: **08.10.2007 PL 38349207**

**(54) Shelf with catches and method of their assembly**

(57) Shelf (3) with catches (1) and method of their assembly, said shelf (3) comprising iron bar elements (4) resting on longitudinal notches (6) situated on the upper

edges (5) of catches (1). Said notches (6) having a length corresponding to the one of the iron bar elements (4). The catches further comprise hook elements (2) that engage in openings situated on the frame of the shelf.

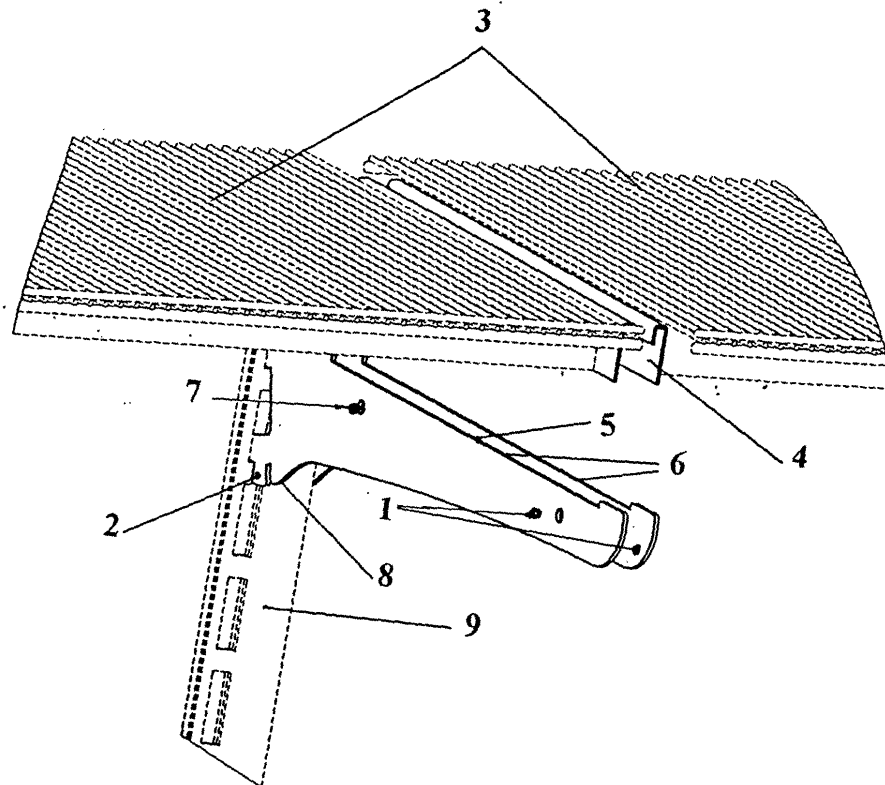

**FIG.1**

**EP 1 958 541 A3**



EUROPEAN SEARCH REPORT

Application Number  
EP 08 00 1499

DOCUMENTS CONSIDERED TO BE RELEVANT			
Category	Citation of document with indication, where appropriate, of relevant passages	Relevant to claim	CLASSIFICATION OF THE APPLICATION (IPC)
X	DE 37 10 898 C1 (KIND GMBH 0) 25 February 1988 (1988-02-25) * column 1, line 55 - column 2, line 62 * * column 3, line 52 - column 4, line 14; figures 1,2,6 *	1-6,8	INV. A47B57/42
X	----- GB 880 471 A (TREPATENT AS) 25 October 1961 (1961-10-25) * the whole document *	8-9	
A	----- * the whole document *	1,4-5	
X,D	----- DE 297 18 748 U1 (WANZL METALLWARENFABRIK KG) 20 November 1997 (1997-11-20) * the whole document *	1-2,4-5,8	
X	----- US 3 199 822 A (RUHNKE) 10 August 1965 (1965-08-10) * column 4, line 5 - line 58; figures 1,12 *	1,4-5,8	
A	----- * column 4, line 5 - line 58; figures 1,12 *	9	
X	----- US 5 613 449 A (PULLMAN) 25 March 1997 (1997-03-25) * abstract; figures 1,2,9 *	1,4,6-8	TECHNICAL FIELDS SEARCHED (IPC)
X	----- GB 844 892 A (EVERTAUT LTD) 17 August 1960 (1960-08-17) * page 1, line 9 - line 61 * * page 2, line 42 - line 88 * * page 3, line 32 - line 55; figures 1,2,4,9 *	1,4,6,8	A47B A47F
The present search report has been drawn up for all claims			
Place of search The Hague		Date of completion of the search 13 October 2009	Examiner Jacquemin, Martin
CATEGORY OF CITED DOCUMENTS X : particularly relevant if taken alone Y : particularly relevant if combined with another document of the same category A : technological background O : non-written disclosure P : intermediate document		T : theory or principle underlying the invention E : earlier patent document, but published on, or after the filing date D : document cited in the application L : document cited for other reasons ..... & : member of the same patent family, corresponding document	

EPO FORM 1503 03/82 (F04/C01)

**ANNEX TO THE EUROPEAN SEARCH REPORT  
ON EUROPEAN PATENT APPLICATION NO.**

EP 08 00 1499

This annex lists the patent family members relating to the patent documents cited in the above-mentioned European search report. The members are as contained in the European Patent Office EDP file on  
The European Patent Office is in no way liable for these particulars which are merely given for the purpose of information.

13-10-2009

Patent document cited in search report		Publication date	Patent family member(s)	Publication date
DE 3710898	C1	25-02-1988	NONE	
-----				
GB 880471	A	25-10-1961	NONE	
-----				
DE 29718748	U1	20-11-1997	NONE	
-----				
US 3199822	A	10-08-1965	NONE	
-----				
US 5613449	A	25-03-1997	NONE	
-----				
GB 844892	A	17-08-1960	NONE	
-----				

EPO FORM P0459

For more details about this annex : see Official Journal of the European Patent Office, No. 12/82