



(11) **EP 1 972 740 A1**

(12) **EUROPEAN PATENT APPLICATION**

(43) Date of publication:  
**24.09.2008 Bulletin 2008/39**

(51) Int Cl.:  
**E04H 1/12 (2006.01)**

(21) Application number: **07381026.9**

(22) Date of filing: **22.03.2007**

(84) Designated Contracting States:  
**AT BE BG CH CY CZ DE DK EE ES FI FR GB GR  
HU IE IS IT LI LT LU LV MC MT NL PL PT RO SE  
SI SK TR**  
Designated Extension States:  
**AL BA HR MK RS**

(72) Inventor: **PEREZ CIDRE, Jose Manuel**  
**28978 Cubas de la Sagra (Madrid) (ES)**

(74) Representative: **Esteban Perez-Serrano, Maria  
Isabel**  
**UDAPI & ASOCIADOS**  
**Explanada, 8**  
**28040 Madrid (ES)**

(71) Applicant: **Cidre Sistem-Linea 3. S.L.**  
**28978 Cubas de la Sagra (ES)**

(54) **Two storey modular structure**

(57) The present invention refers to a two storey modular structure of the type used as stands in trade fairs and exhibitions. The structure is formed on the basis of extruded profiles defining longitudinal beams and cross beams and pillars whose connection points are joined by fitting clips which are able to absorb small misalignments produced between consecutive profiles. The invention is characterised by the fact that the connection points per-

taining to the upper storey include at least one longitudinally winged connection in the grooves of which means of connection are joined to at least a pair of longitudinal beams or cross beams in a vertical position, and arranged between these beams the means for absorption of misalignments and increasing rigidity of the structure by means of articulation clips

**EP 1 972 740 A1**

**Description****OBJECT OF THE INVENTION**

[0001] The present invention refers to a two storey modular structure of the type used as stands at trade fairs and exhibitions.

[0002] The structure is shaped on the basis of extruded profiles defining longitudinal beams, cross beams and pillars whose connection points are joined by fitting clips which are able to absorb small adjustments occurring in consecutive profiles.

[0003] The invention is characterised by the fact that the connection points pertaining to the upper storey include at least one longitudinally winged connection in the grooves of which means of attachments connect with at least one pair of longitudinal beams or crossbeams situated in a vertical position and provided between these the means for absorbing misalignments and rigidity of the structure in the form of articulation clips.

[0004] In this way using an easy and rapid assembly system, it is possible to articulate a second storey which fulfils the requirements of structural rigidity.

**BACKGROUND TO THE INVENTION**

[0005] Structures used as stands at trade fairs and conferences are well known. These stands require means which will enable them to be assembled and dismantled rapidly and yet at the same time they should possess structural rigidity.

[0006] The present applicant has a wide variety of registrations which incorporate, as a connection point between profiles, a longitudinally winged connection point in the grooves of which is inserted the end of an attachment part in the form of an articulated pin at one of its ends. This type of modular assembly permits considerable versatility in construction as well as providing structural rigidity and enabling rapid assembly and dismantling.

[0007] The present invention aims to make use of the previously described elements to create a structure suitable for a two storey stand with the functional features described above.

**DESCRIPTION OF THE INVENTION**

[0008] The present invention refers to a two storied modular structure of the type used as stands in trade fairs and exhibitions.

[0009] The main purpose of the invention is to configure a stand in which the upper storey possesses the adequate requirements for supporting the upper floor as well as other construction elements, for example, handrails.

[0010] The structures between the lower floor and the upper floor are configured in such a way that they possess a high rigidity as well as ease of assembly and dis-

mantling due to the modular form

[0011] The stand is essentially formed on the basis of extruded profiles which configure longitudinal beams and cross beams and pillars, in such a way that they comprise connection points which are provided with fitting clips which enable possible misalignments to be absorbed during assembly of the stand, and which provide the connections with a high degree of rigidity.

[0012] Connection points are understood to be the connections between longitudinal beams and cross beams, the connections with lower pillars and connections of construction elements which may be situated above, such as for example pillars or handrails.

[0013] These connections according to this invention include at least one longitudinally winged connection part in the grooves of which connection means join with at least one pair of longitudinal beams or cross beams situated in a vertical position, and arranged between these are means for absorption of misalignments and rigidity of the structure by means of articulation clips.

[0014] The simplest case would be the connection of a pair of longitudinal beams or cross beams to a winged connection part, however, other items of this invention include for example, a connection point where various pairs of longitudinal beams coincide with crossbeams. The object of situating between the pairs of longitudinal beams or cross beams a means for permitting articulation clips to be situated obeys the need both to increase the rigidity of the mezzanine and to permit the aforementioned means to absorb possible misalignments between elements.

**DESCRIPTION OF THE DRAWINGS**

[0015] The present descriptive report is supplemented by a series of drawings illustrative of a preferred embodiment but not however restricting the invention in any way.

[0016] Figure 1 shows a perspective diagram of an embodiment of a two storey structure according to the subject of the invention.

[0017] Figure 2 shows an opened out perspective diagram of a preferred embodiment of a connection between longitudinal beams and crossbeams of the mezzanine.

[0018] Figure 3 shows an opened out perspective diagram of another preferred embodiment of the means of connection between longitudinal beams and crossbeams.

[0019] Figure 4 shows an opened out perspective diagram of a preferred embodiment of a connection between a pillar of the mezzanine.

[0020] Figure 5 shows a perspective opened out diagram of a preferred embodiment of the means of connection between a connection point with a pillar.

**PREFERRED EMBODIMENT OF THE INVENTION**

[0021] Figure 1 represents a preferred embodiment of

a modular two storey structure for stands. The structure has a lower storey (9) and an upper storey(10) on the upper storey(10) it is possible to situate other construction elements such as the solado itself, pillars which support the roof, hand rails, facings etc.

**[0022]** The structure which is the subject of this invention is formed on the basis of extruded profiles which configure pillars (6) and horizontal profiles (2) that is longitudinal beams (2.1) and crossbeams (2.2) so that they define connection points which are provided with articulation clips (3). These articulation clips are equivalent to those divulged in utility model application no. U9702005, filed in the name of the same applicant which enables the rigidity of the connections to be maintained, as well as absorbing possible misalignments between profiles.

**[0023]** The longitudinal beams (2.1) may be of a greater length than that existing between each connection point or they may have the same length as occurs in the case of the crossbeams 2.2) configuring in this case a reticulate structure.

**[0024]** Figure 2 represents a preferred embodiment of a connection point of the mezzanine corresponding to the case in which the connection point joins the ends of four pairs of horizontal profiles (2). The connection point includes a longitudinally winged connection part (1) in the grooves of which four pairs of horizontal profiles are connected (2).

**[0025]** The winged connection part (1) of the preferred embodiment in figure 2 possesses an essentially oval configuration the faces of which are provided with a number of longitudinal striated wings (1.1). Other configurations would be possible for the connection part (1), for example it could be quadrangular.

**[0026]** In correspondence with the wings (1.1) the horizontal profiles (2) at least one longitudinal groove (2-3) for the introduction of at least one articulation clip (3). This clip (3) fits in the striated wings (1.1) of the connection part (1) permitting the absorption of misalignments between both elements (1.2).

**[0027]** The preferred embodiment of figure 2 would correspond to the connection point on which the panels for the flooring are situated, so that in this case the horizontal profiles (2) are provided in the upper operative position with at least one central vertical partition (2.4) for situating the floor panels.

**[0028]** Figure 3 represents another preferred embodiment of the invention in which a connection point also links up with four pairs of horizontal profiles (2), however in this case the longitudinal beams (2.1) possess a greater length than that existing between the consecutive connection points so that its ends do not join the corresponding connection point.

**[0029]** The connection point includes a longitudinally winged connection part (1) in the grooves of which connection means join the pairs of horizontal profiles (2).

**[0030]** The winged connection part (1) of the preferred embodiment in figure 3 possesses an essentially octagonal configuration from the points of which longitudinal

striated wings (1.1) emerge.

**[0031]** The horizontal profiles (2) have an essentially square section and each of their faces are provided with at least one striated groove (2.5). The central part is also provided with a longitudinal slot (2.6) for housing some clips (3). In this way the crossbeams (2.2) are provided with the means for connecting the longitudinal beams (2.1) by introducing a clip (3) from the crossbeams (2-2) into the grooves (2.5) of the longitudinal beams (2.1).

**[0032]** Figure 4 shows another preferred embodiment of the invention corresponding to a connection point linking a lower pillar (6) and other upper construction elements such as for example hand rails.

**[0033]** In this embodiment the pillars (6) correspond to the quadrangular grooved profiles.

**[0034]** The horizontal profiles (2) are also provided with an essentially square form and are provided on each of their faces with at least one striated groove (2.5) which enables connection to the other construction elements.

**[0035]** In the connection points corresponding to figure 2, figures 3 and 4, the means for positioning the articulation clips (3) between pairs of horizontal profiles (2) comprise at least one profile (5) which is provided with the means to fit at least one pair of articulation clips (3) destined to be coupled to the aforementioned horizontal profiles (2) which form part of the pair. In these embodiments the profile (5) is provided with three housings for fitting the three articulation clips (3). Nevertheless, in figure 3, the profile (5) between the crossbeams (2.2) is only provided with a housing for a pair of clips (3) as it is not necessary to use further pairs of clips (3) due to its short length.

**[0036]** The profile (5) is also provided at both lateral ends with respective striated grooves (5-2) which therefore enable connection of the articulation clips (3).

**[0037]** In order to make the structure more rigid and to absorb misalignment between horizontal profiles (2) and the connection part (1) and to serve as a means of connection between both elements (1, 2), there is also another profile (4) situated between the aforementioned elements and the profile (5).

**[0038]** The profile (4) is also provided with means for fitting at least the respective articulation clips (3) between the connection part (1) and the contiguous profile (5). In the preferred embodiments of the figures the profile (4) is provided with three housings (4.1) for fitting three pairs of articulation clips (3). It is also provided with a profile (4) with respective upper and lower terminations which have a striated groove (4.2).

**[0039]** Both profiles (4, 5) are therefore equal when simply turned at a degree of 90°. For the connection between pillars (6) and an octagonal connection profile (1) the connection point which is the object of the invention is provided with connection means between the aforementioned profiles so that the corresponding connection point is made more rigid.

**[0040]** Figure 5 represents the interior connection element (7) of the point represented in figure 4 which is

provided with a lower part (7.1) which may be housed inside the housing (1.2) of the connection part (1) followed by a rod (7.2) which may be housed inside the octagonal connection part (1) followed above by a part (7.3) destined to be fitted in a housing (1.2) with a quadrangular profile.

**[0041]** The part (7.3) may be provided with an upper extension (7.4) for assembly with a constructive element such as, for example a hand rail profile.

**[0042]** The preferred embodiment is additionally provided with brackets (8) as a means of reinforcement between perpendicular horizontal profiles (2) which are provided internally with articulation clips (3) for their connection to the corresponding longitudinal beams (2).

### Claims

1. Two storey modular structure formed on the basis of extruded profiles which determine horizontal profiles (2) and pillars (6) the connection points of which are provided with connections by means of articulation clips (3) **characterised in that** the connection points corresponding to the mezzanine comprise at least one connection part (1) which is longitudinally winged and in the grooves of which connection means to at least one pair of horizontal profiles (2) situated in a vertical position are connected, with means between them (2) for positioning the articulation clips (3).
2. Two storey modular structure according to claim 1, **characterised in that** the winged connection part (1) possesses an essentially octagonal configuration from the points of which longitudinal striated wings (1.1) emerge.
3. Two storey modular structure according to claim 1, **characterised in that** the winged connection part (1) possesses an essentially quadrangular configuration the faces of which have striated longitudinal grooves(1.1)
4. Two storey modular structure according to claim 1, **characterised in that** the winged connection part (1) possesses an essentially oval configuration.
5. Two storey modular structure according to claim 1, **characterised in that** the horizontal profiles (2) are provided with a longitudinal slot (2.3) for the introduction of at least one articulation clip (3).
6. Two storey modular structure according to claim 5, **characterised in that** the horizontal profiles (2) are provided above with at least one central partition (2.4).
7. Two storey modular structure according to claim 5, **characterised in that** the horizontal profiles (2) have an essentially quadrangular form.
8. Two storey modular structure according to claim 7, **characterised in that** the horizontal profiles (2) are provided on each of their faces at least one striated groove(2.5).
9. Two storey modular structure according to claim 1, **characterised in that** the means for positioning the articulation clips (3) between the pairs of horizontal profiles (2) comprise at least one profile (5) which is provided with the means for housing at least one pair of articulation clips (3) designed to be coupled to the pair of horizontal profiles (2).
10. Two storey modular structure according to claim 9, **characterised in that** the means for positioning the articulation clips (3) consist of housings (5.1).
11. Two storey modular structure according to claim 9, **characterised in that** the profile (5) has on both sides a winged striated termination (5.2).
12. Two storey modular structure according to claims 1 and 9, **characterised in that** is has a part (4) which is provided with connection means between the winged connection part (1) and the pair of horizontal profiles (2) to house at least one pair of connection clips (3) for attaching at least one pair of connection clips (3) for attachment to the connection part (1) and to the connection part (5) joining the horizontal profiles (2).
13. Two storey modular structure according to claim 12, **characterised in that** the means of housing of the part (4) for the clips (3) are slots (4.1).
14. Two storey modular structure according to claim 12, **characterised in that** the part (4) is provided above and below with winged striated terminations (4.2).
15. Two storey modular structure according to claim 1, **characterised in that** the pillars (6) correspond with quadrangular profiles the faces of which have striated longitudinal grooves (1.1).
16. Two storey modular structure according to claims 1 and 15 **characterised in that** it comprises the means for connecting the pillars (6) and an octagonal part (1).
17. Two storey modular structure according to claim 16 **characterised in that** the means of connection between the pillars (6) and the octagonal connection part (1) consists of a device (7) which is provided with a lower part (7.1) susceptible to fitting inside the

housing (1.2) of the connection part (1) followed by a rod (7.2) susceptible to fitting in the interior of the octagonal connection part (1) followed above by a part (7.3) destined to be fitted in a housing (1.2) with a quadrangular profile.

5

18. Two storey modular structure according to claim 17, **characterised in that** the part (7.3) is provided with an upper extension (7.4) for assembly with an additional construction element.

10

19. Two storey modular structure according to claim 1, **characterised in that** it is provided with brackets (8) as a means of providing reinforcement between longitudinal perpendicular beams (2) which have housing for the respective connection clips (3) attaching to the corresponding horizontal profiles (2).

15

20

25

30

35

40

45

50

55

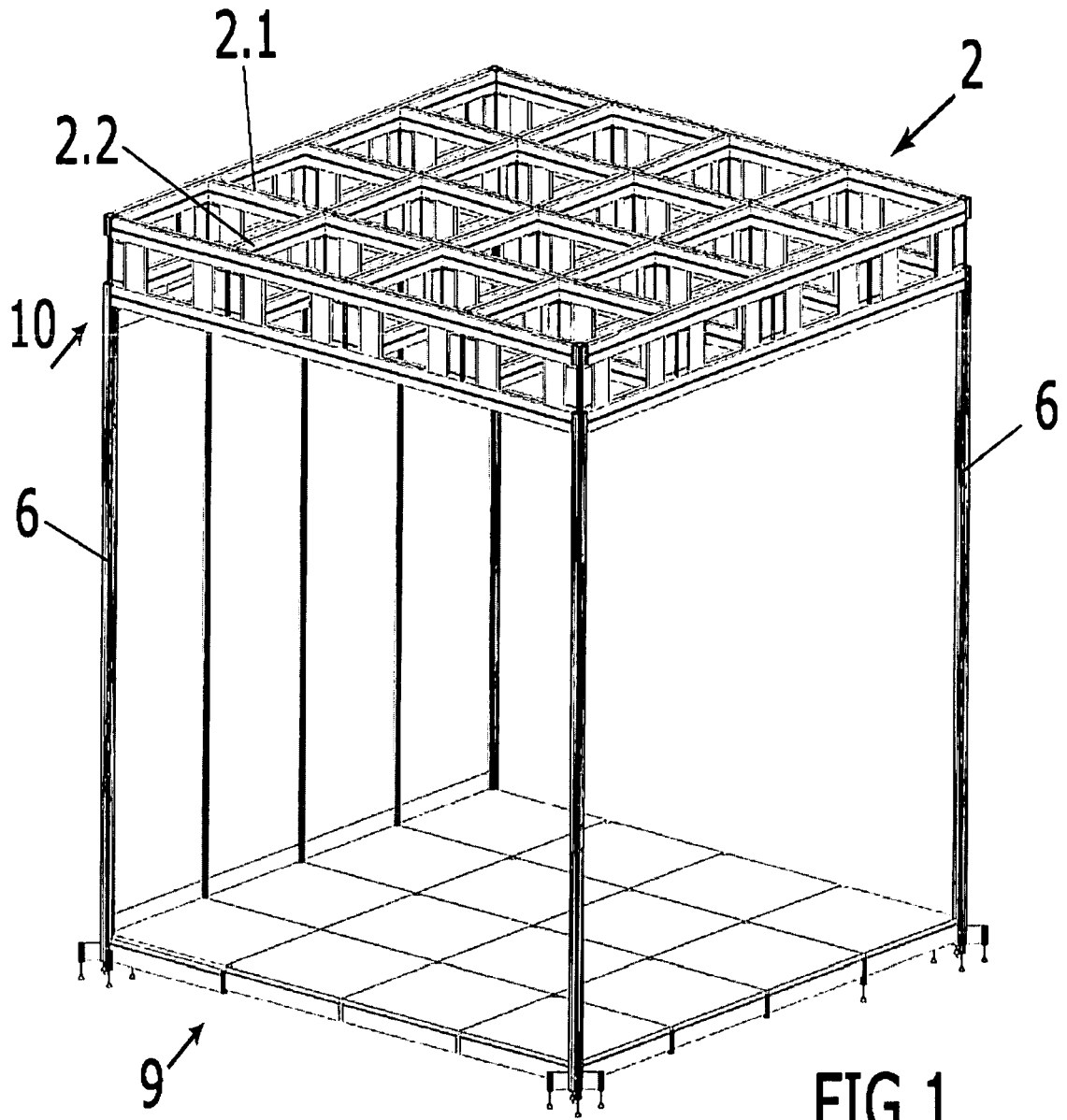
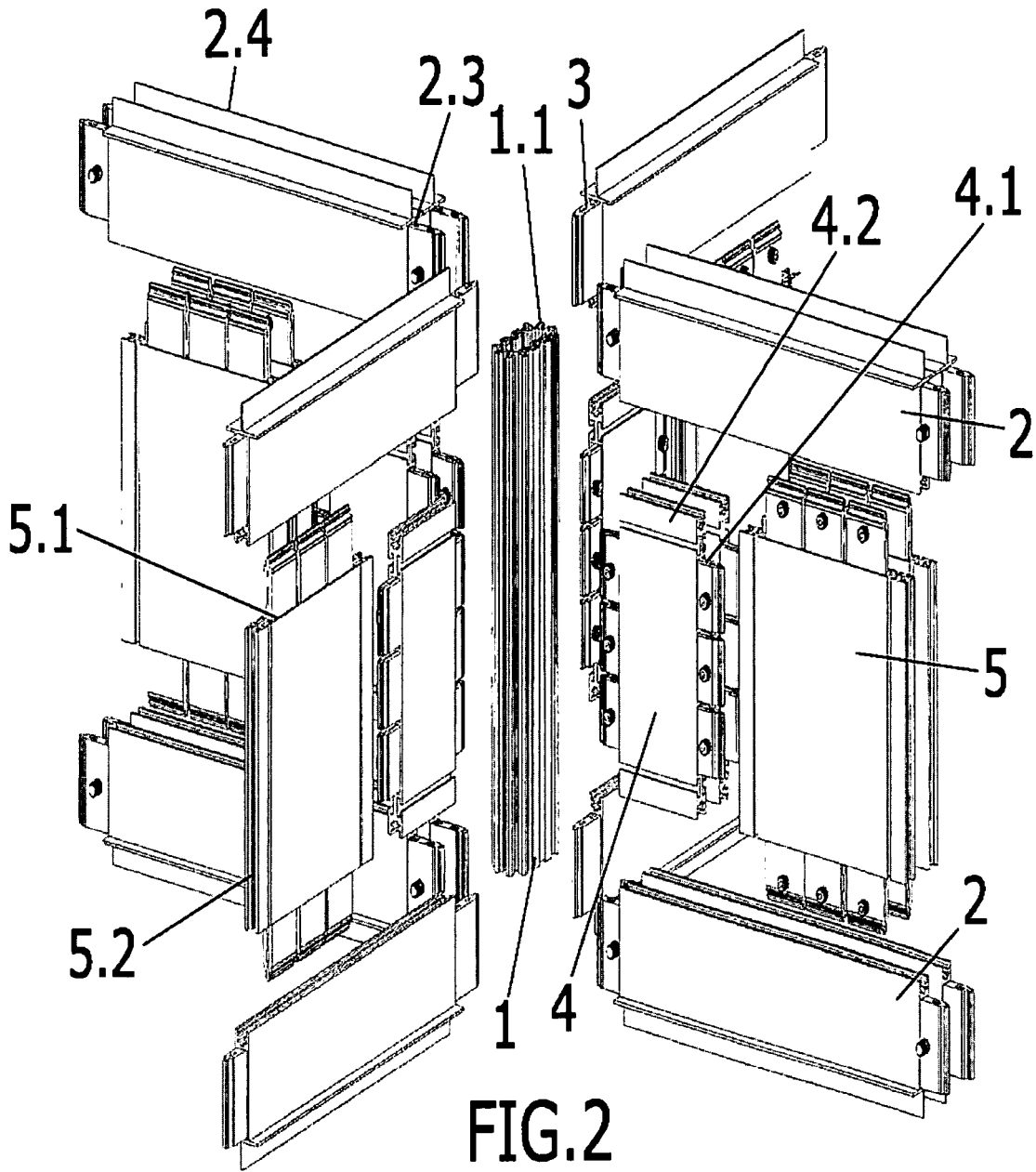
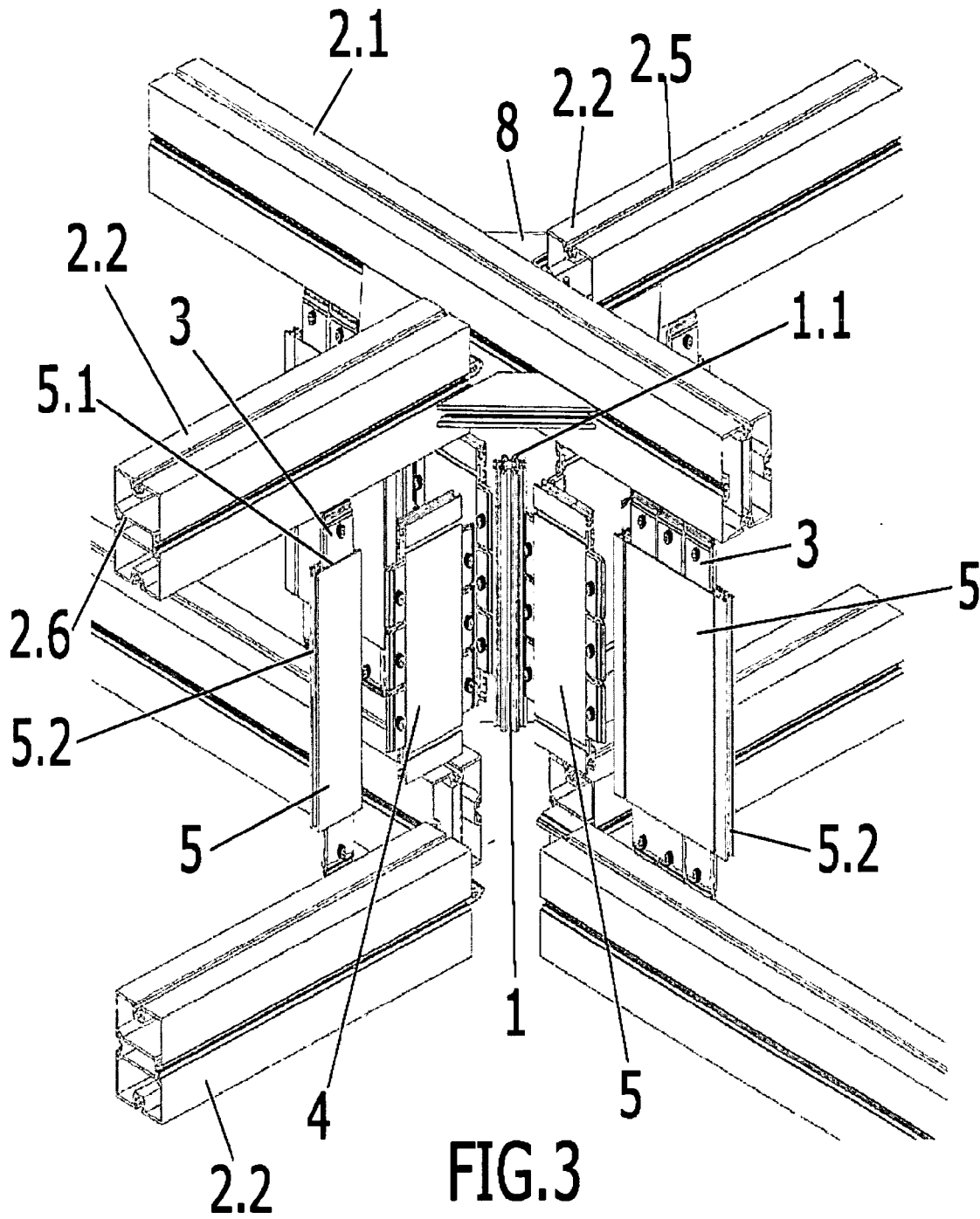
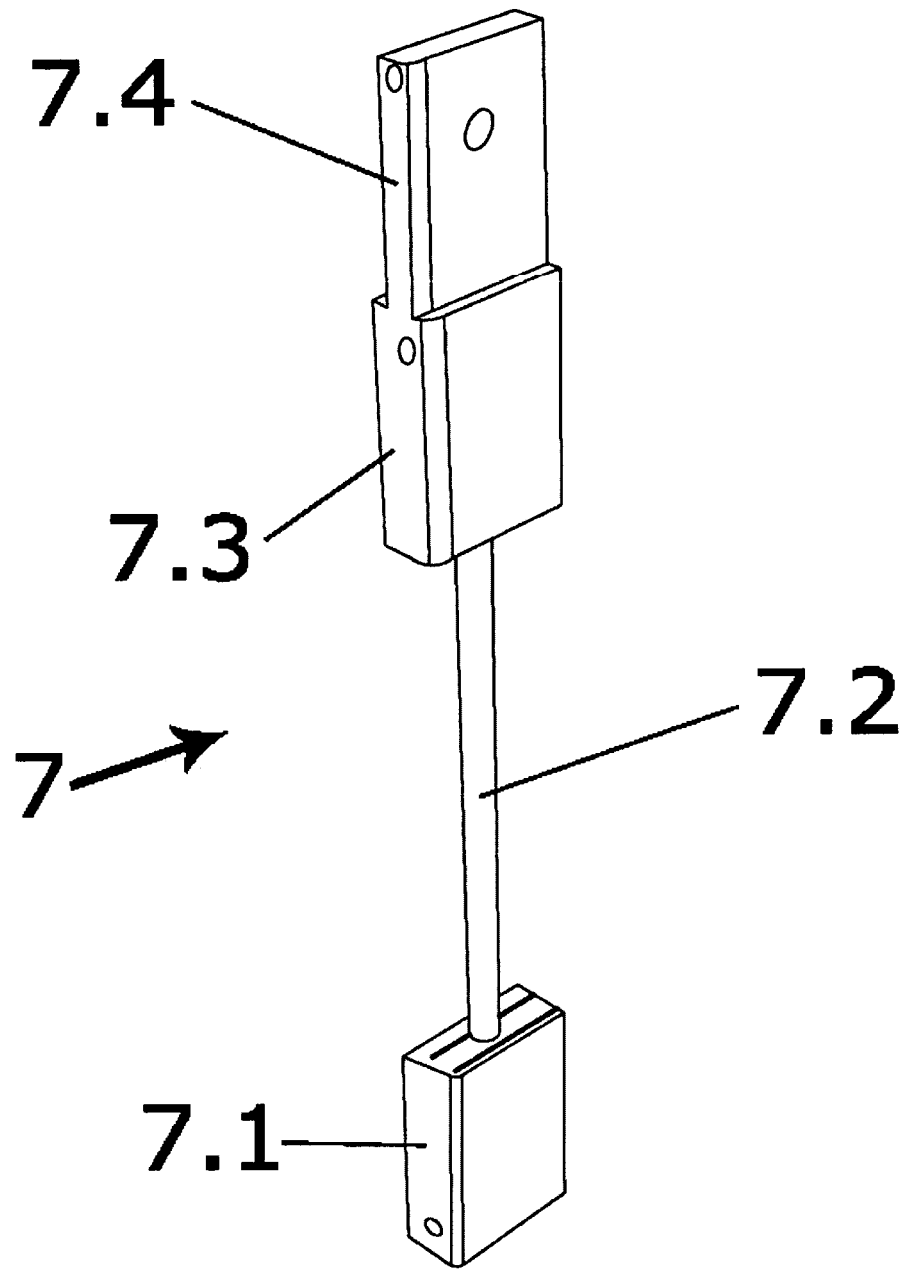

FIG. 1









**FIG. 5**



DOCUMENTS CONSIDERED TO BE RELEVANT			
Category	Citation of document with indication, where appropriate, of relevant passages	Relevant to claim	CLASSIFICATION OF THE APPLICATION (IPC)
X	DE 93 04 055 U1 (MERO-RAUMSTRUKTUR GMBH & CO WUERZBURG, 8700 WUERZBURG, DE) 27 May 1993 (1993-05-27)	1,3,5, 7-13,15	INV. E04H1/12
Y	* the whole document *	2,4,6, 16,17,19	
Y	----- DE 198 49 352 A1 (BEKHJET FAUZI [DE]) 4 May 2000 (2000-05-04)	2,16,17	
A	* claims 1,28; figures 4,5 *	1	
Y	----- EP 0 284 122 A (JONKER ROBERT GERARD CORNELIS) 28 September 1988 (1988-09-28)	4	
A	* the whole document *	1	
Y	----- DE 33 03 190 A1 (OCTANORM VERTRIEBS GMBH [DE]) 9 August 1984 (1984-08-09)	6,19	
A	* page 10, last paragraph - page 11, paragraph 1 *	1	
A	* page 12, paragraph 3; figures 4,7 *	1	
A	----- US 2001/004432 A1 (PFISTER JOEL W [US]) 21 June 2001 (2001-06-21)	1	TECHNICAL FIELDS SEARCHED (IPC)
A	* paragraph [0037]; figures *		E04H
A	----- US 5 095 677 A (GODBOUT CHARLES [CA] ET AL) 17 March 1992 (1992-03-17)	1	
A	* the whole document *		
A	----- EP 0 976 891 A2 (OCTANORM VERTRIEBS GMBH [DE]) 2 February 2000 (2000-02-02)	1	
A	* the whole document *		
-----			
The present search report has been drawn up for all claims			
Place of search		Date of completion of the search	Examiner
The Hague		16 August 2007	Fordham, Alan
CATEGORY OF CITED DOCUMENTS			
X : particularly relevant if taken alone		T : theory or principle underlying the invention	
Y : particularly relevant if combined with another document of the same category		E : earlier patent document, but published on, or after the filing date	
A : technological background		D : document cited in the application	
O : non-written disclosure		L : document cited for other reasons	
P : intermediate document		..... & : member of the same patent family, corresponding document	

2

EPO FORM 1503 03 82 (P04C01)

**ANNEX TO THE EUROPEAN SEARCH REPORT  
ON EUROPEAN PATENT APPLICATION NO.**

EP 07 38 1026

This annex lists the patent family members relating to the patent documents cited in the above-mentioned European search report. The members are as contained in the European Patent Office EDP file on  
The European Patent Office is in no way liable for these particulars which are merely given for the purpose of information.

16-08-2007

Patent document cited in search report		Publication date	Patent family member(s)	Publication date
DE 9304055	U1	27-05-1993	NONE	
-----				
DE 19849352	A1	04-05-2000	NONE	
-----				
EP 0284122	A	28-09-1988	NL 8700434 A	16-09-1988
-----				
DE 3303190	A1	09-08-1984	NONE	
-----				
US 2001004432	A1	21-06-2001	US 2001010779 A1	02-08-2001
-----				
US 5095677	A	17-03-1992	NONE	
-----				
EP 0976891	A2	02-02-2000	AT 279618 T	15-10-2004
			CN 1244642 A	16-02-2000
			CZ 9902716 A3	16-02-2000
			ES 2229592 T3	16-04-2005
			HK 1024280 A1	08-04-2005
			PL 334675 A1	31-01-2000
			SK 98899 A3	13-03-2000
-----				