



(11) **EP 1 978 196 A2**

(12) **EUROPEAN PATENT APPLICATION**

(43) Date of publication:
08.10.2008 Bulletin 2008/41

(51) Int Cl.:
E05F 15/14^(2006.01)

(21) Application number: **08153038.8**

(22) Date of filing: **19.03.2008**

(84) Designated Contracting States:
**AT BE BG CH CY CZ DE DK EE ES FI FR GB GR
HR HU IE IS IT LI LT LU LV MC MT NL NO PL PT
RO SE SI SK TR**
Designated Extension States:
AL BA MK RS

(30) Priority: **22.03.2007 ES 200700632 U**

(71) Applicant: **Grup Tecnoport Canet, S.L.**
08360 Canet de Mar (ES)

(72) Inventor: **Roca Iglesias, Jordi**
08360, CANET DE MAR (ES)

(74) Representative: **Ponti Sales, Adelaida**
Oficina Ponti
C. Consell de Cent, 322
08007 Barcelona (ES)

(54) **Driving device for sliding doors**

(57) The driving device for sliding doors, comprising a rack (1) integral with the sliding door, a driving pinion (2) engaged with said rack (1) driven by a motor (3) integral with said pinion (2), that is vertically movable, and it is **characterised in that** the pinion (2) or the motor (3) are linked with a spring (4) that presses said pinion (2) against the rack (1), engaging the pinion (2) with the rack (1).

It permits to guarantee a pressure engagement of the pinion with the rack and permits to absorb the irregularities in the height of the rack, permitting therefore the fixation of the rack to the sliding door to be carried out at the factory, that guarantees a better quality and a decrease of the cost, because the final adjustment is not carried out at the building site.

EP 1 978 196 A2

Description

[0001] The present invention refers to a driving device for sliding doors, of the kind including a rack and a pinion.

BACKGROUND OF THE INVENTION

[0002] Driving devices for sliding doors are known, which are used to drive laterally a door that rests against a rail, and comprising a rack fixed to the door and a pinion driven by a motor, generally integral with the floor and by a clutch system permitting to place the pinion out of mesh for e.g. to permit the manual driving of the door.

[0003] However, this configuration presents the drawback that the rack must be fixed to the door at the same building site, once the rail is installed. This is because the regularity and linearity of the rail against which the sliding door slides determines the optimal position of the rack of the door.

[0004] On the other hand, even though an adjust of the installation at the building site is carried out, this does not permit to adapt completely the rack to the irregularities because it is rigid and it only permits a height and inclination adjustment.

[0005] This lack of adjustment gives rise in a short term irregularities in the advancement of the door, and in a long term, a wear of the components of the mechanism, especially the meshing teeth and the motor shaft, because of the stresses created between the pinion and the rack.

[0006] A solution to this drawback is to permit the pinion to move in a vertical sense following the rack in a vertical sense, adapting it therefore to the irregularities of the floor.

[0007] Specifically, a solution available in the market is a motor-pinion assembly mounted on a box that can swing about an horizontal axis and orthogonal to the direction of the rack, the motor-pinion assembly being offset with respect to the axis, so that it can move in the vertical direction. As the preferred arrangement of the racks in sliding doors is with the teeth oriented downwardly, forcing to place the pinion under the rack, this kind of mechanisms also comprise a wheel placed at the height of the pinion at the other side of the rack and integral with the motor-pinion assembly, and whose end is to guarantee that the pinion follows the rack. This wheel is detachable, so that it permits to disengage the pinion, such as it is required in this devices.

[0008] However, this configuration, even though has advantages because of its simplicity because it acts by gravity, has the drawback that the entire box is rotated, and therefore, it does not permit e.g. to engage to it complementary systems of sliding doors, such as a detection system with infrared photocells.

[0009] Therefore, it is apparent the need to provide an enhanced driving device of sliding doors solving said drawbacks.

DESCRIPTION OF THE INVENTION

[0010] With the driving device for sliding doors object of the invention said drawbacks are solved, presenting other advantages that will be described hereinafter.

[0011] The driving device for sliding doors object of the invention comprises a rack integral with the sliding door, a driving pinion engaged with the rack driven by a motor integral with the pinion, which is vertically movable, and it is characterised in that the pinion or the motor are linked to a spring that presses the pinion against the rack, so that it is engaged with the rack.

[0012] This tracking system guarantees the pressure engagement of the pinion with the rack and permits to absorb the irregularities of the height of the rack, permitting therefore the fixation of the rack to the sliding door to be carried out at the factory, which guarantees an enhanced quality and a decrease of the costs because the final adjustment is not carried out at the building site.

[0013] Preferably, the device of the invention comprises a substantially vertical guide along which the motor or the pinion, or the motor-pinion assembly, can slide, so that the motor-pinion assembly is forced to be moved vertically that necessary to absorb the advancement irregularities.

[0014] Advantageously, the spring is placed substantially in a vertical direction and it is a tensile spring, which guarantees a greater stability of the system.

[0015] More preferably, the device object of the invention comprises means to place the other end of the spring at least at two different heights, so that in a first position the pinion presses against the rack and in a second position the pinion is disengaged, providing a disengaging system that permits to install more comfortably the device or to drive manually the door if it is needed.

[0016] More advantageously, the device comprises a rod placed inside the spring and has a length slightly lower than it, so that the rod presses the pinion to the disengagement position.

[0017] The end of this rod is to reduce the decrease of the elongation of the spring when it is disengaged, because the spring, as exerts a considerable force on the rack and also holds the motor-pinion assembly, has a considerable elongation when it is engaged, and therefore, if there is no rod, it would be necessary a considerable height difference between both positions, which would be detrimental for the compactness of the assembly.

[0018] Even more preferably, the device comprises a pin integral with the spring and placed at the other side of the rack, i.e. at the opposed part of the pinion, so that it prevents the disengaging of the pinion when the end of the spring is in said first position and in that said pin is removed when the end of the spring is in said second position.

[0019] This pin, when the sliding door is blocked or when an excessive force is applied to the engaged teeth, prevents the motor to be disengaged and its revolution

counter to provide an erroneous position of the mechanism.

[0020] Preferably, the means to place the other end of the spring at least at two heights comprises a cam whose end is linked with said other end of the spring, said cam being integral with a gear that meshes with another gear integral with a driving lever, providing therefore a simple system for disengaging the device.

[0021] Furthermore, the device of the invention is housed inside a substantially rectangular box and the lever, in its engagement position, is part of the box, providing a compact and easy to assemble device.

[0022] Advantageously, said motor comprises a rotatable position reader connected to control means. Therefore, with the rotatable position reader it is possible to know at each moment where is the door and thus there are not necessary end stroke detectors in the door. Furthermore, thanks to the position reader it is possible to control the force and prevent accidents in a person or object.

BRIEF DESCRIPTION OF THE DRAWINGS

[0023] To permit the understanding of what has been explained some drawings are attached in which, diagrammatically and only as a non-limitative example, a practical case of embodiment of the driving device for sliding doors object of the invention is shown, in which:

Fig. 1 is a vertical section of the device of the invention when the pinion and the rack are engaged;

Fig. 2 is a vertical section of the invention when the pinion and the rack are not engaged;

Fig. 3 is a perspective view of the device of the invention when the pinion and the rack are engaged;

Fig. 4 is a perspective view of the device of the invention when the pinion and the rack are not engaged;

Fig. 5 is a vertical section of the device of the invention when the pinion and the rack are engaged;

Fig. 6 is a vertical section of the device of the invention when the pinion and the rack are not engaged;

Fig. 7 is a frontal view of the device of the invention when the pinion and the rack are not engaged in which the position of the pin is shown; and

Fig. 8 is a frontal view of the device of the invention when the pinion and the rack are engaged in which the position of the pin is shown.

DESCRIPTION OF A PREFERRED EMBODIMENT

[0024] According to a preferred embodiment of the invention, and it is shown in Figs. 1 to 4, the driving device for sliding doors of the invention comprises a rack 1 integral with the sliding door (not shown), a driving pinion 2 engaged with said rack driven by a motor 3 integral with said pinion, which can be vertically moved, and in which the pinion 2 or the motor 3, of the motor-pinion

assembly, are linked with a spring 4 that presses said pinion 2 against the rack 1, engaging the pinion 2 with the rack 1, so that when the rack 1 moves along a direction perpendicular with respect to the representation plane, the pinion 2 can move vertically always in contact with the rack 1 by the spring 4, which presses it against the rack 1.

[0025] It must be pointed out that the teeth of said pinion 2 are suitably sized to obtain more fit and to decrease the possibility of a break of a teeth if the door abuts with any obstacle.

[0026] To guarantee that the motor 3 and pinion 2 assembly is a stable position and it only moves in the interest position, i.e. vertical direction, the device comprises a substantially vertical guide (not shown), which is substantially aligned with the spring 4, which is driven so that the pinion-motor assembly slides upwardly thanks to the guide up to a position in which it engages with the rack 1.

[0027] To disengage the rack from the pinion, e.g. to drive manually the door because of e.g. a fault in the electric energy supply or any other cause, the device comprises a cam 5 that permits to place the upper end of the spring 7 between two positions, corresponding one of them to a position such as the spring remains tightening enough so that the force of the pinion 2 on the rack 1 is enough to drive the rack 1, and therefore the door, in movement, and corresponding the other to a situation in which the pinion 1 is disengaged.

[0028] As the vertical force that the pinion must exert on the rack is considerable, the spring, in the engaging position, is very tightened, so that it would be necessary a distance between the other two positions of the upper end 7 of the spring 4, that would involve a cam 5 with great dimensions that would be detrimental for the optimal dimensions and the compactness of the device.

[0029] To solve this drawback, the device comprises a rod 8 placed inside the spring 4, so that when the spring 4 reduces its working length in a length with respect to the variations of the height provided of the rack 1, the pinion 2 can be disengaged from the rack without changing so much the elongation of the spring 4.

[0030] Furthermore, according to a preferred embodiment of the invention and as it is shown in Figs. 5 to 8, the device comprises a pin 9, cinematically linked with the cam 5 so that when it is in the engaging position, the pin 9 is above the motor-pinion assembly and in front the pinion 2 at the other side of the rack 1, so that the rack is placed between both and, in the case of a jamming of the rack 1, the pin 9 prevents the rotation of the pinion 2 not dragging the rack 1, preventing therefore the rotation counter of the motor to provide an erroneous information and preventing also the uncomfortable creaking that is produced when the pinion 2 slips on the rack 1.

[0031] The kinematical link between the cam and the pin can be carried out with a horizontal guide of the pinion placed in the wall of the box and a sliding guide that can slide by the spring, so that the swinging of the spring drives the movement of the pin, as it can be seen in Figs.

5 and 6.

[0032] Furthermore, said pin 9 is adjustable in height to be adapted to different models of racks where the device of the present invention can be mounted.

[0033] When the cam 5 is placed in the disengagement position, the pin 9 is retracted so that the pinion 2 can be lowered, as it can be seen in Figs. 6 and 7.

[0034] The driving of the cam by the user is carried out by a lever 10 integral with a gear 11 that meshes with another gear 12 integral with the cam 5, having said gear

a radius relation that permits a comfortable driving by the user.

[0035] Furthermore, the device of the invention is housed inside a box 13, formed partially by the disengaging lever 10, so that the assembly is provided in a compact format to make the installation easier.

[0036] Advantageously, said motor 3 comprises a rotatable position reader, usually known in the art as "encoder", connected to electronic control means (not shown) to control always the position of the door and prevent therefore possible accidents, because it is possible to control also always the presence of an obstacle during the operation of the door.

[0037] Even though reference is made to a specific embodiment of the invention, it is apparent for a person skilled in the art that the disclosed device is susceptible of numerous variations and modifications, and that all the details cited can be substituted by other technically equivalent ones, without departing from the scope of protection defined by the attached claims.

Claims

1. Driving device for sliding doors, comprising a rack (1) integral with the sliding door, a driving pinion (2) engaged with said rack (1) driven by a motor (3) integral with said pinion (2), that is vertically movable, **characterised in that** the pinion (2) or the motor (3) are linked with a spring (4) that presses said pinion (2) against the rack (1), engaging the pinion (2) with the rack (1).

2. Device according to claim 1, **characterised in that** it comprises a substantially vertical guide along which the motor (3) or the pinion (2) can slide.

3. Device according to claim 1, **characterised in that** the spring (4) is placed substantially in a vertical direction and **in that** it is a tensile spring.

4. Device according to claim 1, **characterised in that** it comprises means (5) to place the other end of the spring (7) at least at two different heights, so that in a first position the pinion (2) presses against the rack (1) and in a second position the pinion (2) is disengaged.

5. Device according to claim 1, **characterised in that** it comprises a rod (8) placed inside said spring (4) and with a length slightly lower than the length of the spring, so that said rod (8) presses the pinion (2) towards said disengaging position.

6. Device according to claim 2, **characterised in that** it comprises a pin (9) integral with the spring (4) and placed at the other side of the rack (1), in the opposed part of the pinion (2), so that it prevents the disengagement of the pinion (2) when the end of the spring (7) is in said first position and **in that** said pin (9) is removed when the end of the spring (7) is in said second position.

7. Device according to claim 4, **characterised in that** said means to place the other end of the spring (7) at least in two heights comprises a cam (5) whose end is linked to said other end of the spring (7).

8. Device according to claim 7, **characterised in that** said cam (5) is integral with a gear (11) and **in that** said gear (11) meshes with another gear (12) integral with a driving lever (10).

9. Device according to claim 1, **characterised in that** it is housed inside a substantially rectangular box (13).

10. Device according to claim 9, **characterised in that** said lever (10), in the engagement position, is part of the box (13).

11. Device according to claim 1, **characterised in that** said motor (3) comprises a rotatable position reader connected to control means.

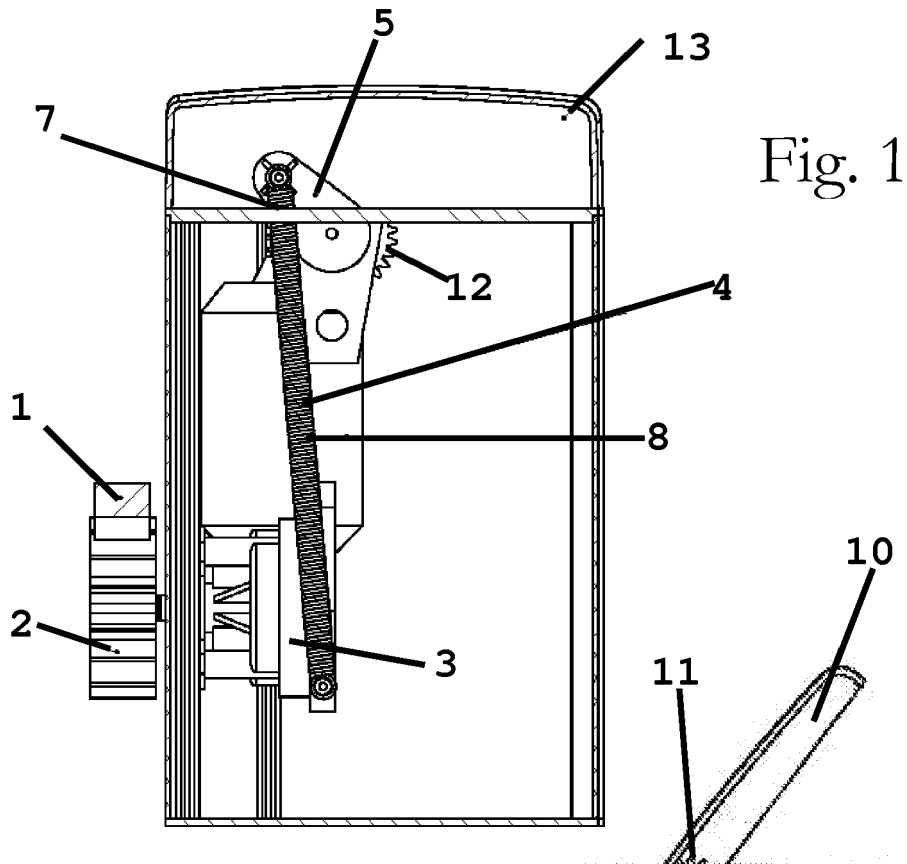

Fig. 2

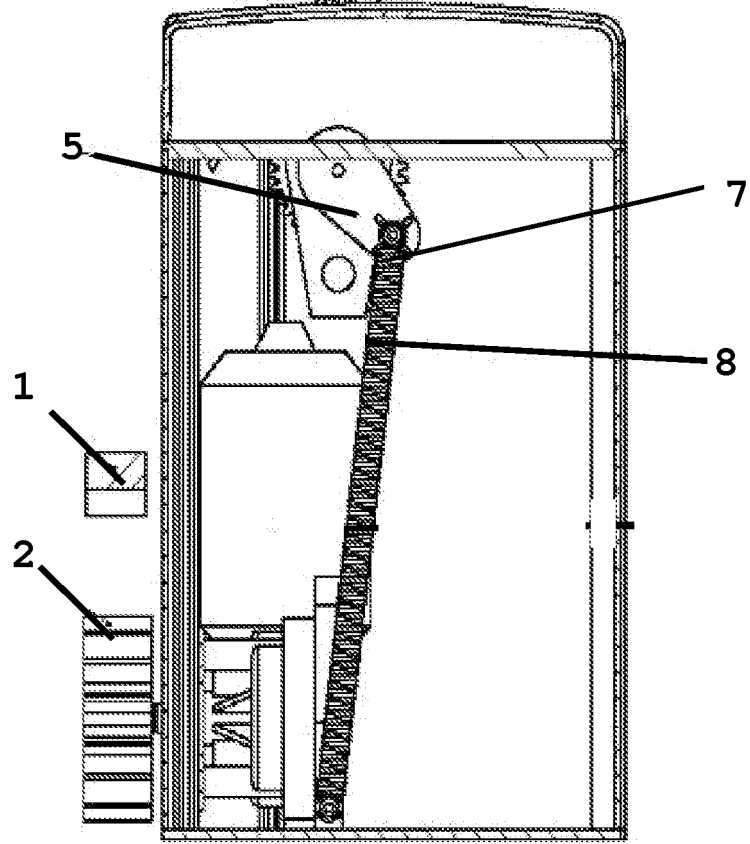

Fig. 3

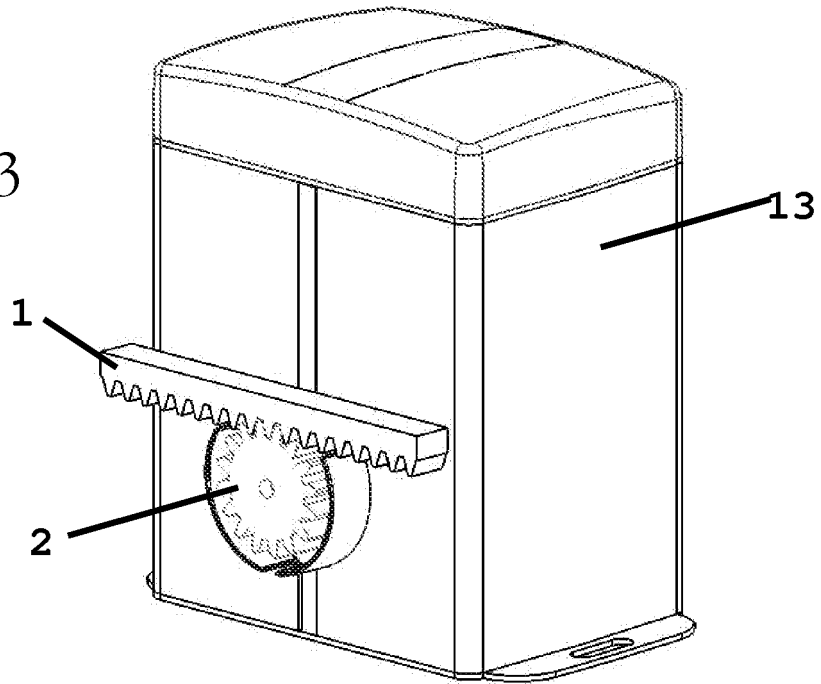

Fig. 4

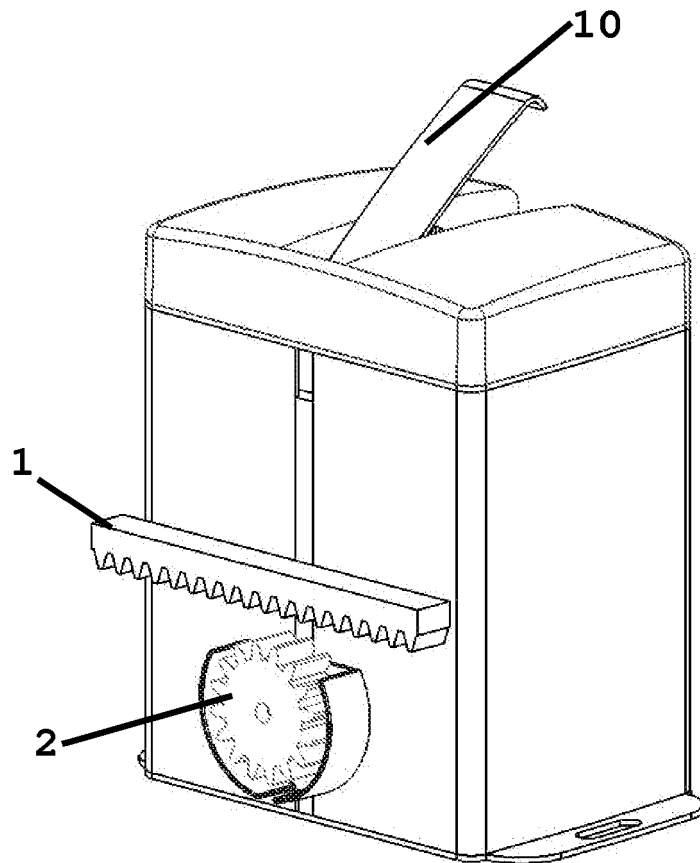

Fig. 5

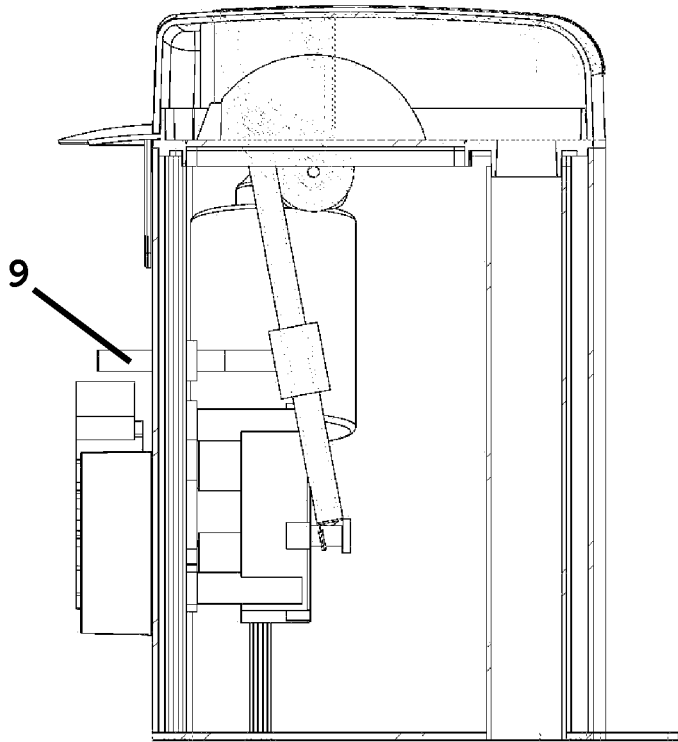

Fig. 6

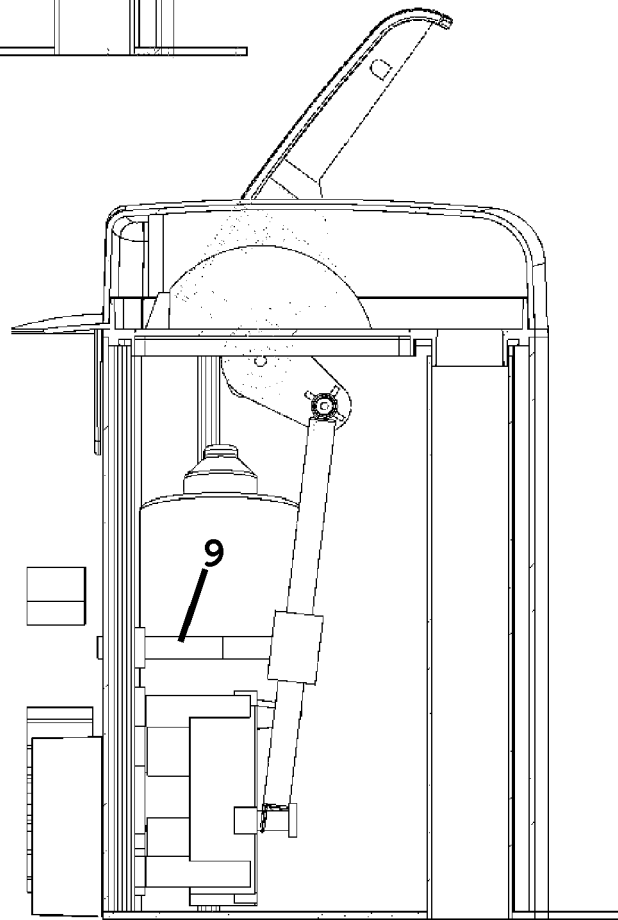

Fig. 7

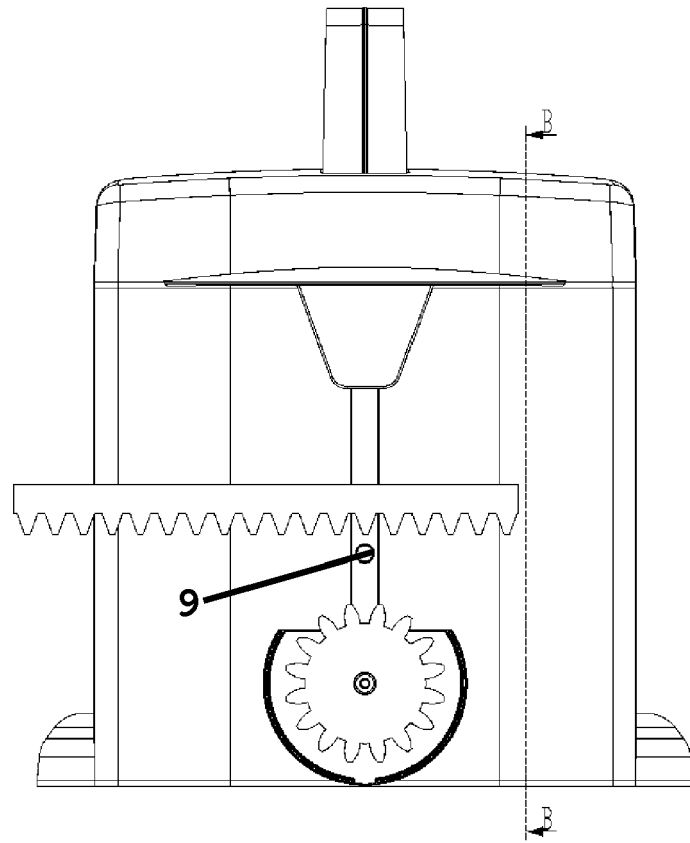

Fig. 8

