

(19)



(11)

EP 1 978 205 A2

(12)

EUROPEAN PATENT APPLICATION

(43) Date of publication:
08.10.2008 Bulletin 2008/41

(51) Int Cl.:
E21B 19/084 (2006.01) **E21B 19/15** (2006.01)
E21B 19/24 (2006.01) **E21B 19/16** (2006.01)

(21) Application number: **08006078.3**

(22) Date of filing: **28.03.2008**

(84) Designated Contracting States:
AT BE BG CH CY CZ DE DK EE ES FI FR GB GR HR HU IE IS IT LI LT LU LV MC MT NL NO PL PT RO SE SI SK TR
Designated Extension States:
AL BA MK RS

(71) Applicant: **SOILMEC S.p.A.**
47023 Cesena,
Forli (IT)

(72) Inventor: **Ditillo, Alessandro**
47023 Cesna (FO) (IT)

(30) Priority: **05.04.2007 IT TO20070242**

(74) Representative: **Lotti, Giorgio**
Corso Vittorio Emanuele II 61
10128 Torino (IT)

(54) **Magnet rod-manipulator device for earth-drilling**

(57) A magnet rod-manipulator device for earth-drilling machines, comprising two permanent magnets (12) constrained to the rotary (14) of the machine, the mag-

nets (12) having the shape of plates provided with cradles (13) and being mobile between a resting position and a position for engagement of a rod (25) for drilling into the earth between said cradles (13).

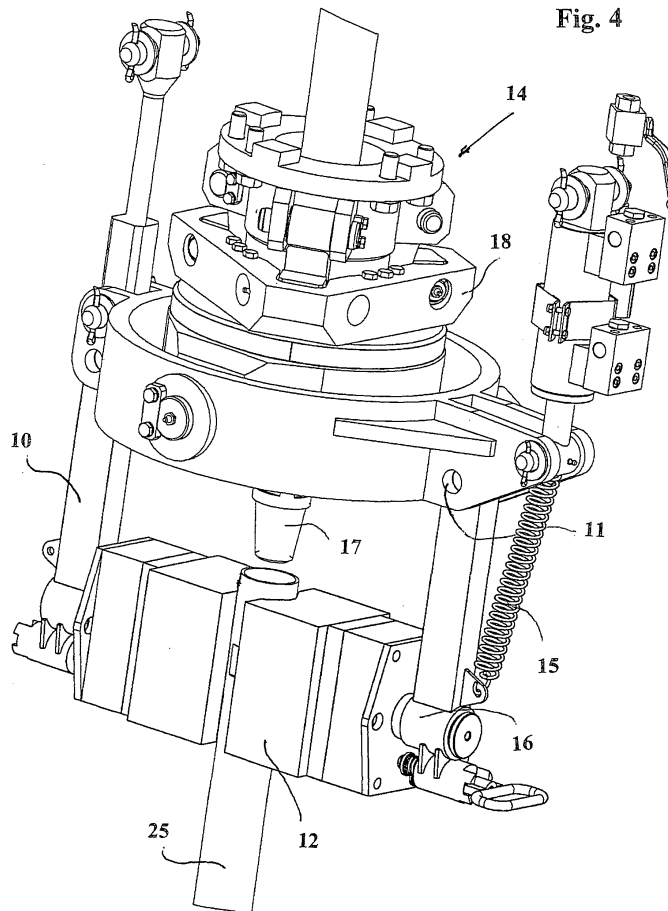

Fig. 4

EP 1 978 205 A2

Description

[0001] For handling the rods and rods/casings in earth-drilling machines, the following equipment is mainly used: loaders, articulated cranes, mixed systems of cranes plus gripping accessories or winch end pieces.

[0002] The equipment consisting of loaders may be of the following types:

a. rack loaders, with possibility of stocking rods or rods and casings on the mast and with hydraulic manipulating gripper that picks the rod up off the rack and positions it at pile centre;

b. revolver loaders, with possibility of stocking rods or rods and casings on the mast and with a system for hydraulic rotation of the supporting arm or jib of the loader that picks the rod up from the rack and positions it at pile centre;

c. simplified-rack loaders: in some machines for digging wells the rack is fixed to the mast, and the rotary, provided with lateral displacement, moves to pick the rod up; the advantage lies in the fact that the manipulator is not required, and the limit is represented by the fact that the rods can be just a few, two or three at the mast;

d. well-rack loaders: in well-drilling machines the rack is located on the basic machine, and an arm picks the rod and sets it aligned (larger number of rods, more complex system).

[0003] Equipment consisting of articulated cranes is normally of the following type: an articulated crane, mounted on the machine, picks the drilling accessories up with hoisting means, such as chains, ropes, "nooses", and threaded rotating elements. Equipment consisting of mixed systems formed by cranes plus gripping accessories is in some cases made using a magnet as gripping member, the rod being lifted by an articulated crane and hydraulically positioned in line with the drilling axis (it works in fixed positions with the mast horizontal or vertical).

[0004] Finally, equipment consisting of winch end pieces is normally made as follows. Located on the end of the mast is an end piece with a winch over which the rope is run. The end piece can be either rotatable or fixed. This system is simple but works only in a vertical direction.

[0005] There then also exist hybrid solutions, such as, for example, magnet grippers set on the hydraulic articulated arm or hydraulic arm with hoisting winch.

[0006] In other cases, an auxiliary vice is provided, mounted on a rotary that fishes the rod from a front trestle and brings it up aligned through a hydraulic rotation of 90° performed by the supporting arm of the vice.

[0007] Alternatively, there is an independent manipulator arm on the ground, or else again a rocking rotary, which fishes the rod from a front chute through the rotation of the entire structure with a hydraulic movement.

[0008] A problem typical of this type of equipment consists in the need to lift rods having a weight of 150 kg vertically or with minimal inclinations, at the same time paying attention to the aspects of costs and stability of the structure.

[0009] In jetting equipment the lattices for extension of the mast prevent the possibility of installing hoisting winches at the ends, and the machines that afford the highest levels of performance become somewhat unstable if lateral loaders or hoisting jibs are used.

[0010] A solution to the aforesaid problems consists in exploiting the push-pull action of the rotary for hoisting and enabling an automatic release of the rod at heights greater than 3 m to prevent the operator from having to "clamber up" (as is the typical case with the use of traditional hoisting gear or of threaded rotating elements).

[0011] In order to obtain this, it is possible to use either a hydraulic vice or a magnet. Vices, however, prove costly, cumbersome (and hence reduce the useful travel), and worsen the stability of the machine.

[0012] According to the present invention, the solution to the aforesaid problem is achieved by employing a magnet that can be used indifferently in the two embodiments: the embodiment with openable arms and the embodiment with chains.

[0013] Consequently, the purpose of the present invention is to provide a magnet rod-manipulator device for use in earth-drilling machines, characterized in that it comprises two permanent magnets constrained to the rotary of the machine, the magnets having the shape of plates provided with cradles and being mobile between a resting position and a position for engagement of a rod for drilling into the earth between said cradles.

[0014] The device according to the invention will now be described with reference to the annexed plates of drawings, in which:

- Figures 1-4 illustrate the device according to the invention in four different operating conditions; and
- Figure 5 illustrates the device in a second embodiment.

[0015] With initial reference to the embodiment of Figures 1-4, two arms 10 may be noted, hinged in 11 to the rotary 14 of the machine, which carry at their two ends respective permanent magnets 12, which present in the form of plates with grooves, having the function of jaws or vices, provided with cradles 13, which are made on the face opposite to the face constrained to the respective arm.

[0016] Springs 15 are mounted so as to function by exerting a tensile force between the rotaries 14 and the arms 10.

[0017] For safety reasons the permanent magnets 10 are of the type with an electromagnetic deactivation circuit.

[0018] During operation of the device, first the rotary 14 comes down, and then the arms 10 set themselves

in the open position (see Figure 1); a rod 25 is loaded and deposited on trestles in an approximately horizontal position (not illustrated), underneath the rotary 14.

[0019] On account of their own weight, the jaws 12 will orient themselves so as to be able to displace with their own cradles 13 a rod set horizontally (Figure 2).

[0020] At this point, the arms 10 are lowered manually overcoming the resistance of the return springs 15 (Figure 3). When the cradles 13 of the jaws 12 come into contact with the rod 25, they are magnetized and grip the rod itself.

[0021] The rotary 14 is hence raised and, by means of the jaws 12, the rod 25 is raised along with it until it is set vertically (Figure 4). During this movement, the jaws 12 rotate about their hinges 16 with which they are connected to the arms 10 following the rotation of the rod, which, from a horizontal position, moves into a vertical position.

[0022] The rotary 14, in a traditional way, lowers the rod 13 within the unscrewing member (which is not illustrated given that it is of a known type), until it fits into the conical threaded joint of an underlying rod. With further exertion of the thrust, the rod 13 slides inside the active jaws 12 until also the top joint has fitted into the end shaped like a truncated cone 17 of the rotary 14. The magnetic jaws 12 are now de-activated, and the arms 10 move up automatically into a resting position under the action of the springs 15.

[0023] Finally, the sleeve 18 of the rotary 14 is made to turn so as to screw the top joint to the bottom joint.

[0024] As may be noted, the arms 10 are mounted on the so-called through vice, which has a stationary outer collar 19 and an internal clamp, rotating (idle) when it is gripped on the rod. This vice and the entire application are typical and particularly indicated for machines designed for jetting, in which usually the travel of the rotary is smaller than the length of the rod mounted initially. The rotary hence requires a through vice, which gets the rod to advance in a number of goes.

[0025] The rods that are subsequently added (using any system) are, instead, necessarily shorter than the travel of the rotary.

[0026] According to an alternative embodiment, the arms 10 can be rotated from the resting position of Figure 2 to that of engagement of the rod 25 of Figure 3 by means of hydraulic/pneumatic motors or cylinders.

[0027] According to a further alternative embodiment of the invention (illustrated in Figure 5), the magnetic jaws 12 are constrained to the rotary 14 by means of chains 20 instead of by the arms 10 of the embodiment described previously.

[0028] This solution facilitates centring of the cradles 13 of the jaws 12 on the rod by the operator, even though the system is less stiff than the previous one during lifting of the rod. At any event, this variant can prove advantageous in the case where the rods already positioned vertically are loaded, in which case it is sufficient to displace the jaws 12 towards the rod and leave the electromagnetic force to grip them on the rod 25.

Claims

1. A magnet rod-manipulator device for earth-drilling machines, **characterized in that** it comprises two permanent magnets (12) constrained to the rotary (14) of the machine, the magnets (12) having the shape of plates provided with cradles (13) and being mobile between a resting position and a position for engagement of a rod (25) for drilling into the earth between said cradles (13).
2. The manipulator device according to Claim 1, **characterized in that** the magnets (12) are constrained to the rotary (14) through the respective arms (10) hinged to the rotary and to the magnets.
3. The manipulator device according to Claim 2, **characterized in that** mounted between the rotary (14) and the arms (10) are springs (15), which tend to keep the arms (10) open when they do not engage a rod between the respective cradles (13).
4. The manipulator device according to Claim 3, **characterized in that** the arms (10) are rotated manually from the resting position to the position of engagement of a rod (25).
5. The manipulator device according to Claim 3, **characterized in that** the arms (10) are rotated from the resting position to the position of engagement by means of hydraulic/pneumatic motors or cylinders.
6. The manipulator device according to Claim 1, **characterized in that** the magnetic jaws (12) are constrained to the rotary (14) by means of chains (20).
7. The manipulator device according to Claim 1, **characterized in that** the permanent magnets (12) are of the type with an electromagnetic deactivation circuit.
8. The manipulator device according to Claim 2, **characterized in that** the arms (10) are mounted on the through vice of the rotary (14) constituted by a stationary outer collar (19) and an inner clamp rotating (idle) if it is gripped on the rod.

Fig. 1

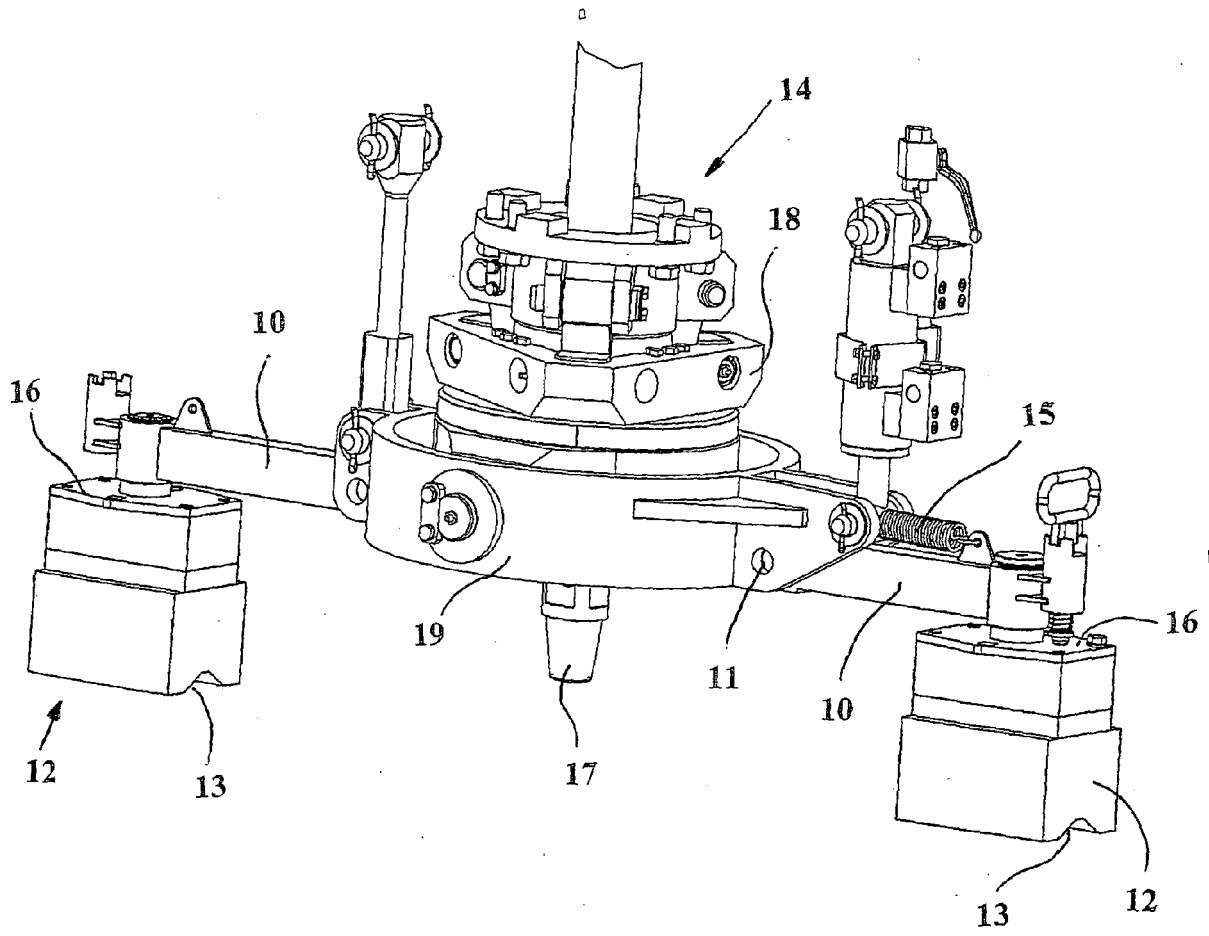

Fig. 2

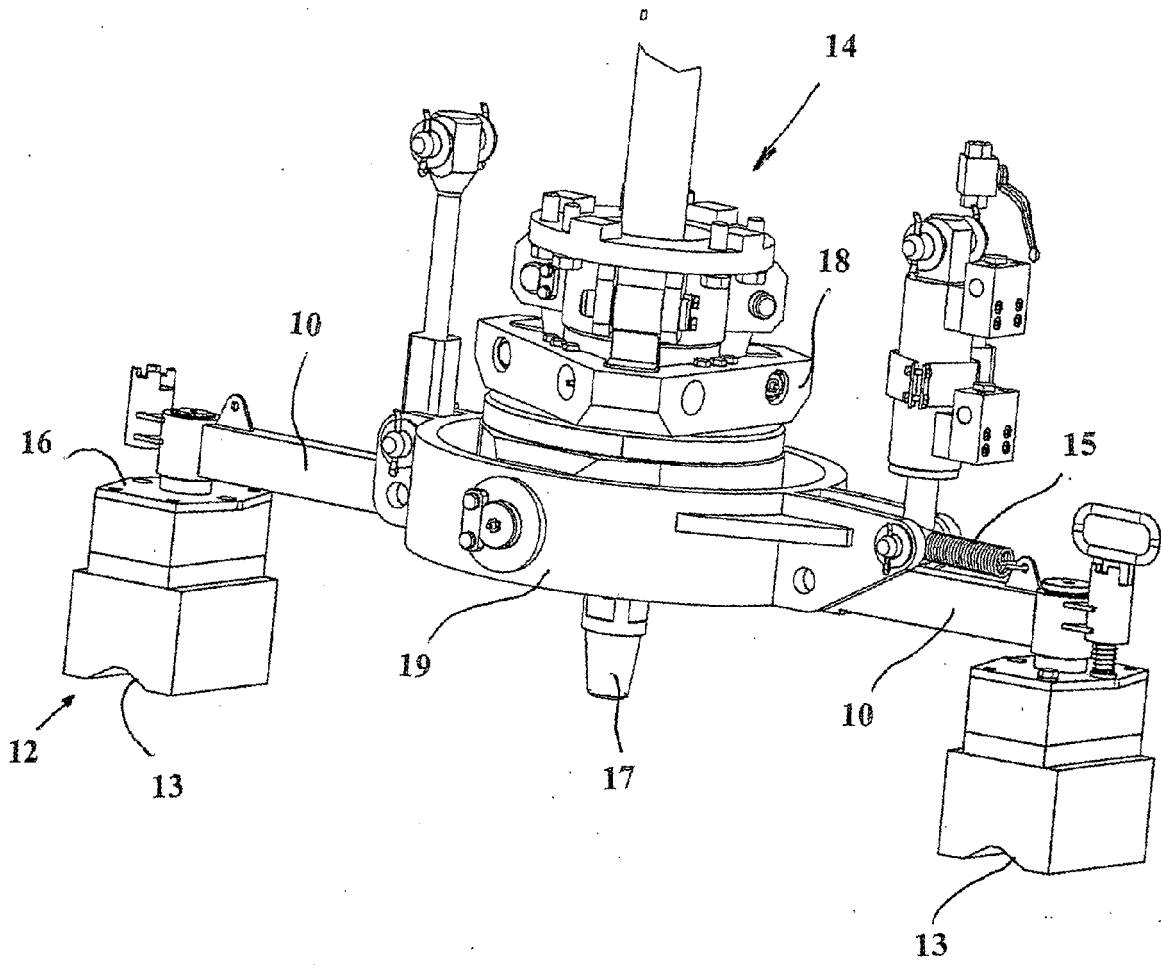

Fig. 3

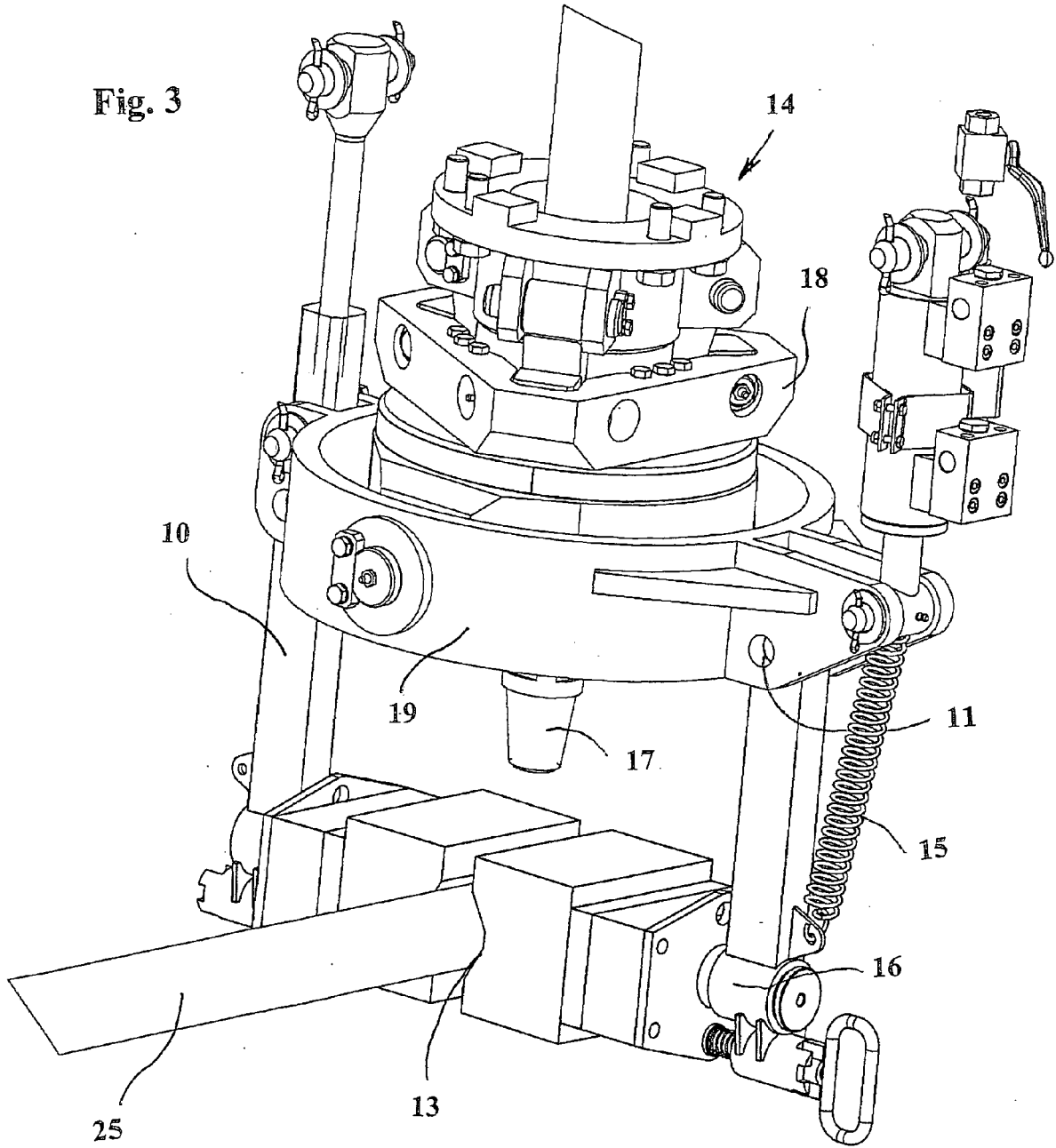

Fig. 4

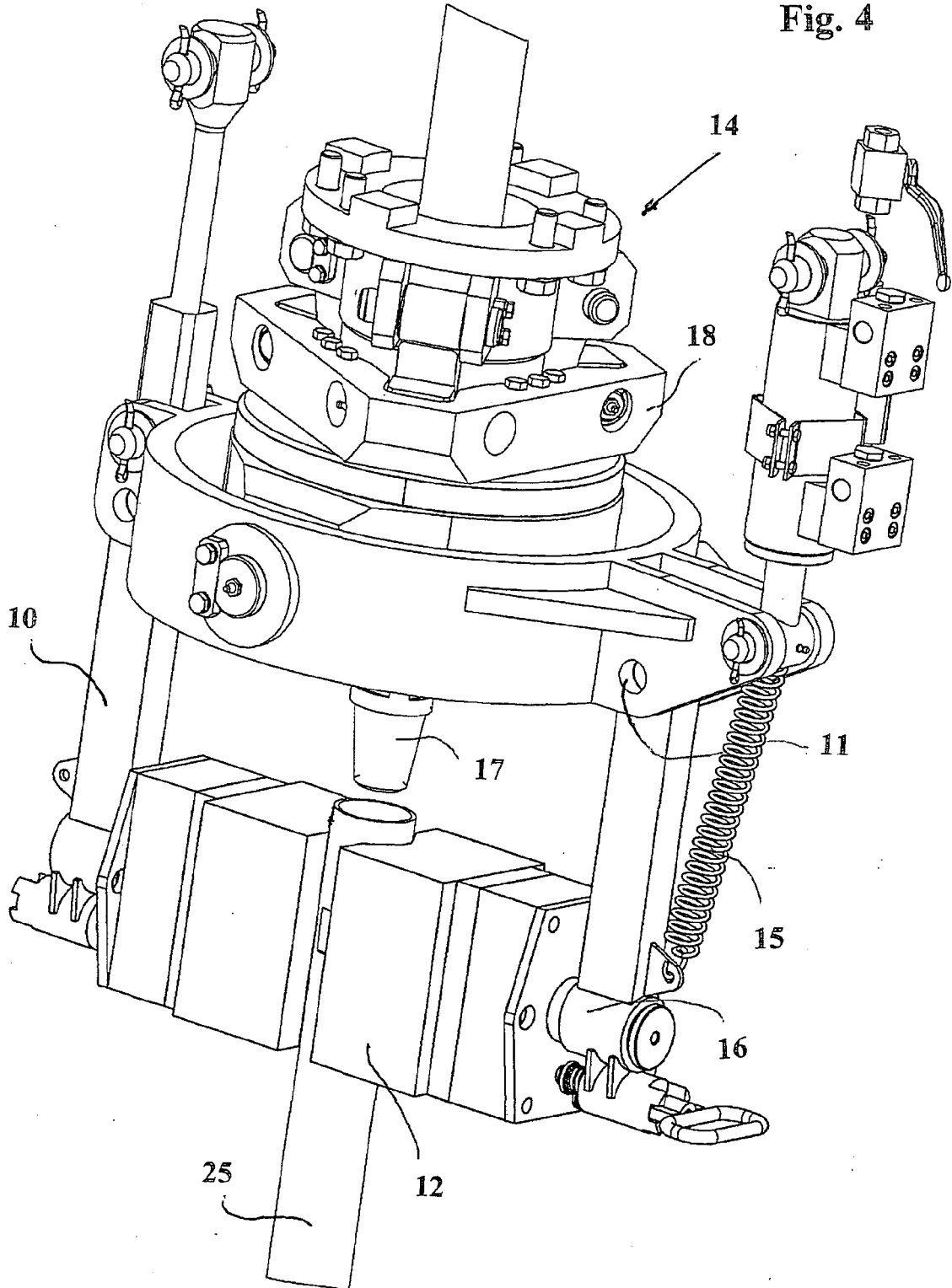

Fig. 5

