

(19)



(11)

EP 1 985 801 A1

(12)

EUROPEAN PATENT APPLICATION

(43) Date of publication:
29.10.2008 Bulletin 2008/44

(51) Int Cl.:
F01D 5/04^(2006.01) F04D 29/02^(2006.01)
F04D 29/28^(2006.01)

(21) Application number: **07008235.9**

(22) Date of filing: **23.04.2007**

(84) Designated Contracting States:
AT BE BG CH CY CZ DE DK EE ES FI FR GB GR HU IE IS IT LI LT LU LV MC MT NL PL PT RO SE SI SK TR
Designated Extension States:
AL BA HR MK RS

(71) Applicant: **SIEMENS AKTIENGESELLSCHAFT**
80333 München (DE)

(72) Inventors:
• **Heyes, Francis**
LN2 1RG Lincoln (GB)
• **Nilsson, Ulf**
LE8 6HN Whetstone, Leicester (GB)

(54) **Impeller coating**

(57) An impeller (12) is provided with a back surface that is at least partly coated with a thermal barrier coating

(14) comprising an anodised layer, polymer or polymer-based ceramics.

FIG 1

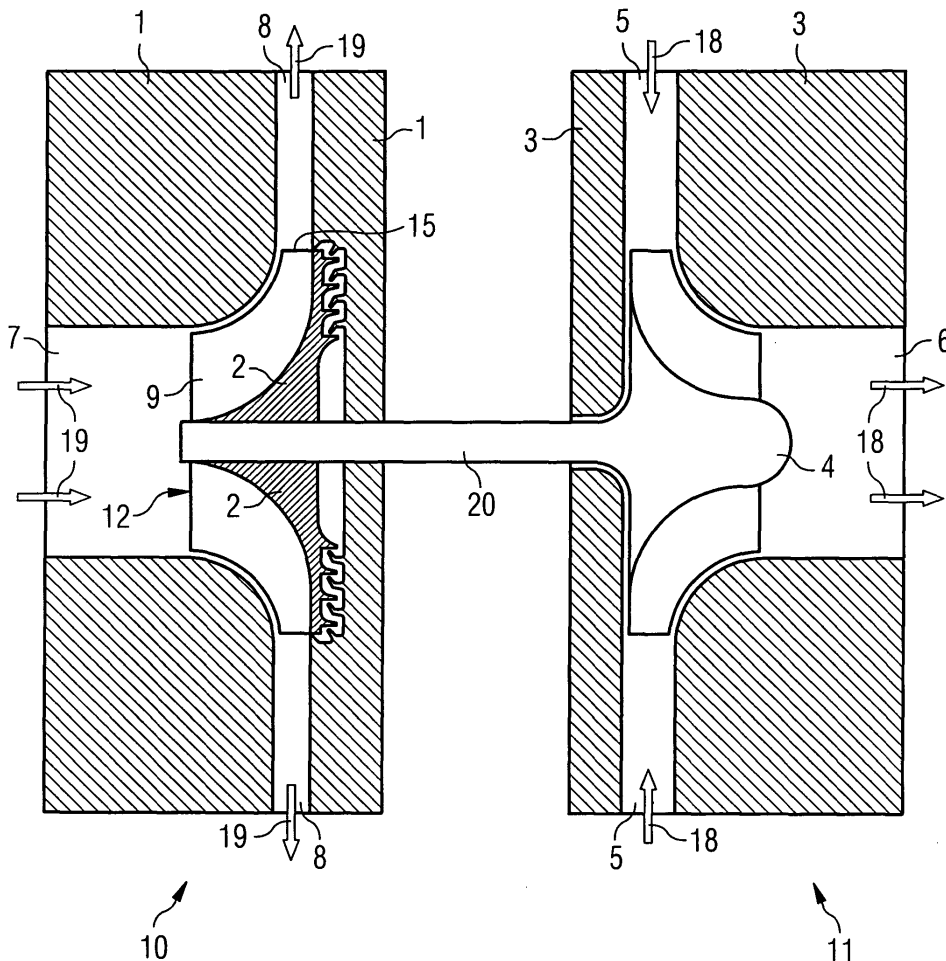

EP 1 985 801 A1

Description

[0001] The present invention relates to a coated impeller and a method for impeller coating.

[0002] Impellers are used in particular in turbochargers, turbocharger compressors, compressors and centrifugal compressors. Typically a turbocharger compressor impeller is made from aluminium and has an averaged life time of 50,000 hours. The life of such an impeller tends to be governed by creep of the impeller material, so that the maximum operating pressure ratios are limited to around 5:1 for typical industrial duties.

[0003] Impeller creep failure is associated with areas of high stress and high temperature. The area of highest temperature is on the back surface of the impeller near the radial outer section. This area, which determines the creep life of the impeller, is an area where typically a labyrinth seal is located to reduce the leakage of compressed air towards the bearings. The high temperature is associated with windage heating in that area. The back face of the impeller is typically 60 degrees hotter than the working area of the impeller at the impeller tip.

[0004] The impeller life must typically reach 50,000 hours. This is traditionally achieved by limiting the operating speed of the turbocharger in line with calculations of the creep life. At lower operating speeds the impeller stresses are lower, the compressed air at the tip of the impeller is cooler and the windage heating is less than at higher operating speed.

[0005] To increase the creep life or to increase the operating speed, respectively, two different solutions have been proposed. As one possibility, cooled air at high pressure has been fed into the area at the back side of the impeller to keep the impeller material cool. The cooled air is usually taken from the diesel engine air manifold, after the compressed air has been cooled by the charge air cooler. The introduction of this cooled air is a parasitic loss on the turbocharger efficiency, since the turbocharger has to compress the coolant air but the air is not used in the diesel engine. Also this cooled air leaks into the main stream of the compressor flow and will cause a disturbance to the flow which reduces the compressor efficiency. Nevertheless, by cooling the impeller, the compressor is allowed to operate at higher speed while still achieving the required 50,000 hours life. Typically an additional 0.2 bar of boost pressure can be achieved with this system and this allows the engine rated power to increase by around 5%.

[0006] As an alternative solution, in US 4,277,222 a turbine engine of the type having a centrifugal air compressor is described. The back surface of the air compressor impeller is coated with a thermally insulating material. This thermally insulating material effectively insulates the relatively cool air compressor from hot leakage gases from the combustor and subsequent turbine engine components thus minimising thermal strain on the compressor and enabling higher compressor speeds and pressure ratios and/or reduced compressor weight. Ce-

ramic material, zirconium oxide and yttrium are disclosed as applicable thermally insulating materials.

[0007] With respect to the mentioned state of the art, it is an objective of the present invention to provide an improved coated impeller.

[0008] This objective is solved by an impeller as claimed in claim 1. The depending claims define further developments of the invention.

[0009] An inventive impeller has a back surface that is at least partly coated with a thermal barrier coating comprising an anodised layer and/or a polymer and/or a polymer-based ceramics. The impeller can comprise a radial outer section which is completely coated with the thermal barrier coating. Alternatively, the back surface of the impeller can exclusively be coated. The coating should have a heat deflection temperature exceeding 250°C. The impeller may be a turbocharger or centrifugal compressor impeller.

[0010] The present invention uses a thermal barrier coating of the outer section of the impeller, specifically on the back surface of the impeller, where the windage heating causes a high temperature on the impeller and a reduction in creep life. Typically this might be in the area of the impeller labyrinth seals. The thermal barrier coating is heated by windage, but the impeller substrate material, typically aluminium, is heated to a lower level. This means that the temperature of the impeller substrate material is reduced and the creep life of the impeller is extended.

[0011] An acceptable minimum thickness of the coating is approximately 0,05-0,1 mm, with a thermal conductivity of the coating being significantly lower than that of the impeller substrate, for instance of the order of 1/10 to 1/1000 of the impeller substrate. The difference in thermal conductivity between aluminium and a polymer may be as high as a factor of 500 or more. Thicker coatings with lower conductivities are more attractive. However, the maximum possible coating thickness is restricted by the forces acting on the coating during operation. These forces have to be transferred via adhesion between the coating and the impeller substrate rather than as a strain load inside the coating itself. This is due to the lower mechanical strength of the coating compared to the base material, i.e. aluminium. This also may require an enhanced surface roughness to improve the adhesion of the coating.

[0012] In the case of aluminium as impeller substrate material, typically the aluminium temperature is reduced by 20 degrees which allows the impeller speed to increase without reducing creep life. An additional 0.2 bar of boost can typically be achieved with this new system compared to the standard impeller which allows the engine rated power to increase by around 5%.

[0013] The thermal barrier coating can comprise multiple layers. For example, the coating to be applied to the impeller may comprise an optional sub-layer made of anodised aluminium, which has been used on aluminium impellers in the past to prevent chemical attack and a

polymer coating. The dual layer coating provides a two step protection where first the polymer layer and finally the anodised aluminium is sacrificed. Multiple layers are also possible, where an outer layer is a good thermal insulator but will not last for a full 50,000 hours at the required operating temperature in all environments. This outer layer may wear out, but an inner layer may survive, allowing some thermal protection to the impeller.

[0014] If the outer layer has some visual distinguishing characteristics, such as colour, the wear of the outer layer may easily be detected during regular maintenance and the impeller or its outer coating can be replaced. This effectively prevents the failure of the impeller and turbocharger. Therefore, in the case of using multiple layers, the outer layer can have visual distinguishing characteristics. Further, the multiple layers can be dual layers comprising a polymer and an anodised layer.

[0015] The polymer used as thermal insulating coating material or as component of multiple layers may be a thermoplastic, especially a reinforced thermoplastic. The thermoplastic can be reinforced by glass fibre or carbon fibre. The polymer can further comprise Polyphthalamid (PPA), Polyetherketon (PEK), Polyetherkethonekethon (PEKK), Polyetheretherketon (PEEK), Polytetrafluorethylen (PTFE) or Thermoplastic Polyimid (TPI). This is valid for the polymer used for the coating with a polymer, but also for the polymer used in multiple layers.

[0016] Furthermore, also the polymer-based ceramics may comprise Polyphthalamid (PPA), Polyetherketon (PEK), Polyetherkethonekethon (PEKK), Polyetheretherketon (PEEK), Polytetrafluorethylen (PTFE) or Thermoplastic Polyimid (TPI). This is valid for the polymer-based ceramics used for the coating with a polymer-based ceramics, but also for the polymer-based ceramics used in multiple layers.

[0017] The use of a thermal barrier coating allows the turbocharger to be run at a higher speed than it would otherwise be the case, while maintaining impeller creep life. In doing so, the turbocharged engine may be operated at higher power and pressure ratios and/or reduced compressor weight.

[0018] The advantage of the invention over the conventionally cooled impeller option is that the parasitic use of compressed and cooled air is significantly reduced and under some circumstances even eliminated and there is less injection of cooling air which could disturb the main compressor air flow. The present invention is therefore more efficient than the fully cooled impeller option.

[0019] Compared to US 4,277,222 the present invention provides an enlarged variety of applicable coating material and coating methods. Especially the coating with anodised aluminium is a cheap solution for thermal insulated coating.

[0020] Further features, properties and advantages of the present invention will become clear from the following description of embodiments in conjunction with the accompanying drawings.

Fig. 1 schematically shows a turbocharger in a sectional view.

Fig. 2 schematically shows the tip of an impeller with coated back surface in a sectional view.

Fig. 3 schematically shows a sectional view of a part of the back surface of the impeller coated with multiple layers.

Fig. 4 schematically shows the coated tip of an impeller with coated back surface in a sectional view.

[0021] In the following a first embodiment of the inventive impeller will be described with reference to Figures 1 to 3. Figure 1 schematically shows a turbocharger in a sectional view. The turbocharger comprises a turbine 11 and a compressor 10. The turbine 11 and the compressor 10 are connected by a shaft 20.

[0022] The turbine 11 includes a rotor 4 which is located inside a turbine casing 3. The turbine casing 3 has an exhaust inlet 5 which leads to the rotor 4 so that the exhaust entering the exhaust inlet 5 activates the rotor 4. Further the turbine casing 3 has an exhaust outlet 6 through which the exhaust coming from the rotor 4 leaves the turbine casing 3. The arrows 18 indicate the exhaust stream entering the turbine casing 3 through the exhaust inlet 5, activating the rotor 4 and leaving the turbine casing 3 through the exhaust outlet 6.

[0023] The compressor 10 includes an impeller 12 which is located inside a compressor casing 1. Moreover, the compressor 10 has an air inlet 7 which air leads to the impeller 12 and an air outlet 8 through which the air coming from the impeller 12 leaves the compressor casing 1. The arrows 19 indicate the air stream entering the compressor casing 1 through the air inlet 7, being compressed by the impeller 12 and leaving the compressor casing 1 through the air outlet 8.

[0024] The impeller 12 comprises a hub 2 and vanes 9. The hub 2 is connected to the shaft 20. Further, the hub 2 is generally conical in shape and a plurality of circumferentially spaced arcuate vanes 9 are formed about its periphery. At the outer section of the impeller 12, measured radially from the shaft 20, the tip 15 is located.

[0025] The rotor 4 of the turbine 11 is connected to the shaft 20 so that the activated rotor 4 activates the shaft 20. The shaft 20 is further connected to the impeller 12 inside the compressor 10. Hence, the rotor 4 activates the impeller 12 by means of the shaft 20.

[0026] In the turbine 11 the exhaust stream 18 entering the exhaust inlet 5 activates the rotor 4 and leaves the turbine through the exhaust outlet 6. The arrows 18 indicate the direction of the exhaust stream. Meanwhile, the impeller 12 in the compressor 10 driven by the rotor 4 sucks atmospherically fresh air into the air inlet 7 and compresses it to precompressed fresh air, which enters the air outlet 8. The compressed air is then used for example in a reciprocating engine like e.g. a diesel engine.

The arrows 19 indicate the air stream direction.

[0027] Figure 2 schematically shows a sectional view of a part of a turbocharger compressor impeller 12 including the hub 2, the vane 9, the tip 15 and a coated back surface 14. The impeller 12 is made from aluminium. One can further see in Figure 2 the outer section of the hub 2 which is connected to or made integral with the outer section of one vane 9. The back surface 16 of the impeller 12 has radially spaced and axially extended ribs 17. Labyrinth seals 13 are mounted to the compressor casing 1 opposite to the back surface 16 of the impeller 12 so as to mesh with the ribs 17. The labyrinth seals 13 engage the annular ribs 17 to reduce the leakage of compressed air towards the bearings along the back surface 16 of the impeller 12.

[0028] In the present embodiment exclusively the radial outer section of the back surface 16 is coated with a thermal insulating anodised layer, a polymer or a polymer-based ceramics 14. Preferably the coating should have a minimal thickness of 0,05mm. In the present embodiment the coating comprises multiple layers. Figure 3 schematically shows a sectional view of a part of the back surface 16 of the impeller 12 coated with multiple layers. The multiple layers comprise an inner anodised aluminium layer 21 and an outer polymer layer 22. As an alternative to the outer polymer layer 22 a layer may be used which is made from a polymer-based ceramics.

[0029] The outer polymer layer 22 has visually distinguishing characteristics, for example a particular colour, so that it is distinguishable from the underlying anodised layer 21. By the distinguishing characteristics the wear of the outer layer 22 may easily be detected during regular maintenance and the impeller or its outer coating can be replaced. This effectively prevents the failure of the impeller and turbocharger.

[0030] The polymer used as thermal insulating coating material may be a thermoplastic. The thermoplastic can be reinforced, for instance by glass fibre or carbon fibre. The polymer or the polymer-based ceramics can further comprise Polyphthalamid, Polyetherketon, Polyetherketoneketon, Polyetheretherketon, Polytetrafluorethylen or Thermoplastic Polyimid.

[0031] Instead of exclusively coating the outer section of the back surface, it is also possible to coat the whole back surface of the impeller.

[0032] Now a second embodiment of the inventive impeller will be described with reference to Figure 4. Elements in Figure 4 corresponding to elements of Figure 2 will be designated with the same reference numeral and will not be described again to avoid repetition.

[0033] Figure 4 shows a part of the turbocharger compressor impeller 12 of Figure 2 but with coated tip 15 and coated back surface 16. Differing from the first embodiment, here the whole radial outer section of the impeller including the tip 15 is coated with thermal insulating material as described in the first embodiment.

[0034] The coating can especially be applied by dipping the impeller tip 15 including the radial outer section

of the back surface 16 into a liquid phase of a polymer or of a precursor of a polymer-based ceramics. After this the polymer or the precursor can be cross-linked or partially cross-linked by treating with heat. Thereafter the precursor of a polymer-based ceramics can be crystallized to a polymer-based ceramics by pyrolysis.

[0035] Although the invention has been described with respect to the impeller of a turbocharger, the invention can also be realised with the impellers of all kinds of centrifugal compressors.

Claims

1. An impeller (12) with a back surface (16) that is at least partly coated with a thermal barrier coating (14), **characterised in that** the thermal barrier coating (14) comprises an anodised layer and/or a polymer and/or a polymer-based ceramics.
2. An impeller as claimed in claim 1, **characterised in that** the impeller (12) comprises a radial outer section which is completely coated with the thermal barrier coating (14).
3. An impeller as claimed in claim 1, **characterised in that** the back surface (16) is exclusively coated.
4. An impeller as claimed in any of the claims 1 to 3, **characterised in that** the impeller (12) is a turbocharger or centrifugal compressor impeller.
5. An impeller (12) as claimed in any of the claims 1 to 4, **characterised in that** the coating (14) has a minimal thickness of 0,05 mm.
6. An impeller (12) as claimed in any of the claims 1 to 5, **characterised in that** the thermal conductivity of the coating is in the order of 1/10 to 1/1000 of the impeller substrate.
7. An impeller (12) as claimed in any of the claims 1 to 6, **characterised in that** the thermal barrier coating (14) comprises multiple layers.
8. An impeller (12) as claimed in claim 7, **characterised in that** the multiple layers have an outer layer with visually distinguishing characteristics.
9. An impeller (12) as claimed in claim 7 or 8, **characterised in that** the multiple layers are dual layers comprising a pol-

polymer and an anodised layer.

10. An impeller (12) as claimed in any of the claims 1 to 9,
characterised in that
the polymer is a thermoplastic. 5
11. An impeller (12) as claimed in claim 10,
characterised in that
the polymer is a reinforced thermoplastic. 10
12. An impeller (12) as claimed in claim 11,
characterised in that
the thermoplastic is reinforced by glass fibre. 15
13. An impeller (12) as claimed in claim 11,
characterised in that
the thermoplastic is reinforced carbon fibre. 20
14. An impeller (12) as claimed in any of the claims 1 to 9,
characterised in that
the polymer comprises Polyphthalamid, Polyetherketon,
Polyetherkethonekethon, Polyetheretherketon,
Polytetrafluorethylen or Thermoplastic Polyimid. 25
15. An impeller (12), as claimed in any of the claims 1
to 9,
characterised in that
the polymer-based ceramics comprises Polyphtha-
lamid, Polyetherketon, Polyetherkethonekethon, 30
Polyetheretherketon, Polytetrafluorethylen or Ther-
moplastic Polyimid.

35

40

45

50

55

FIG 1

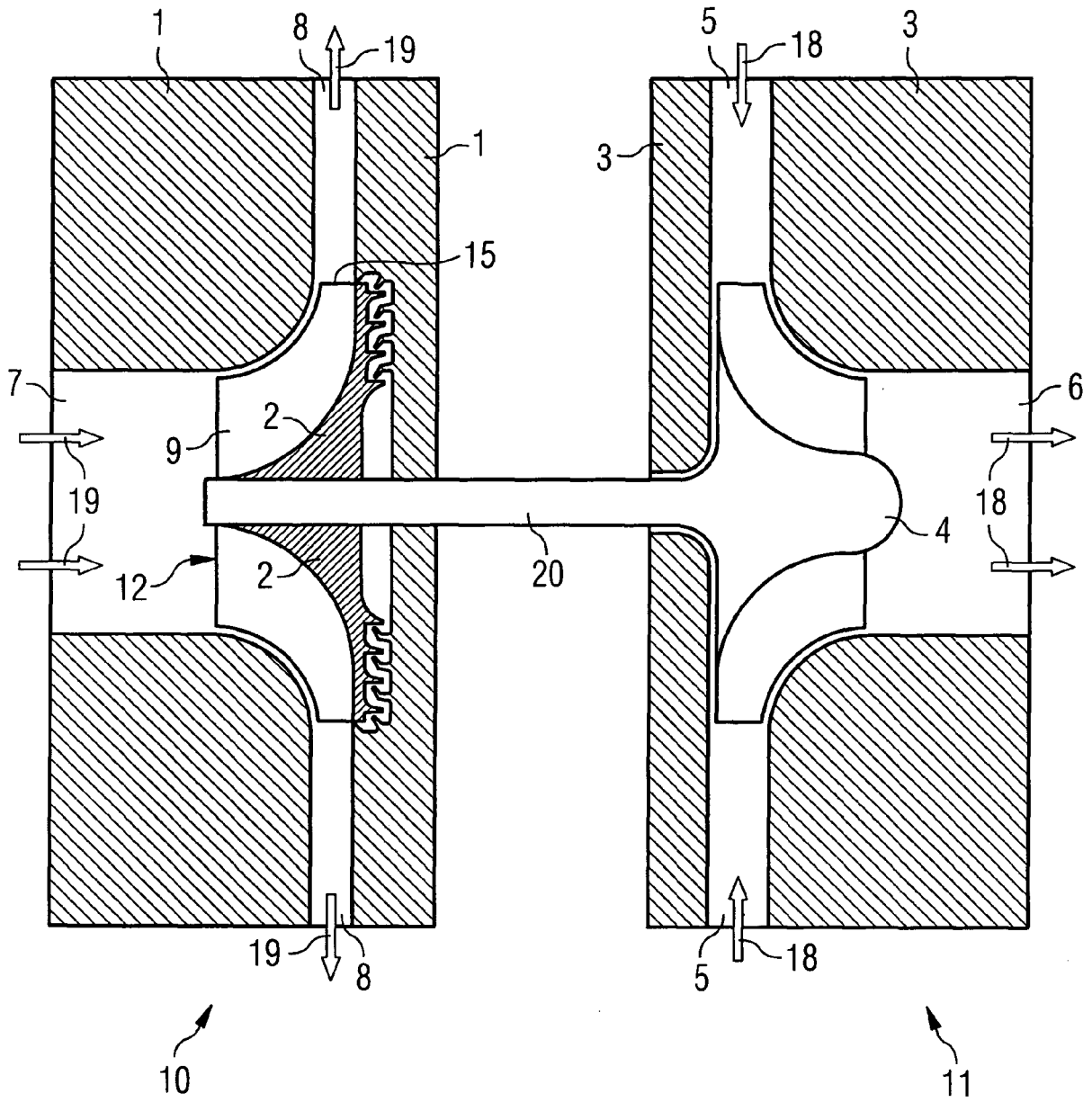

FIG 2

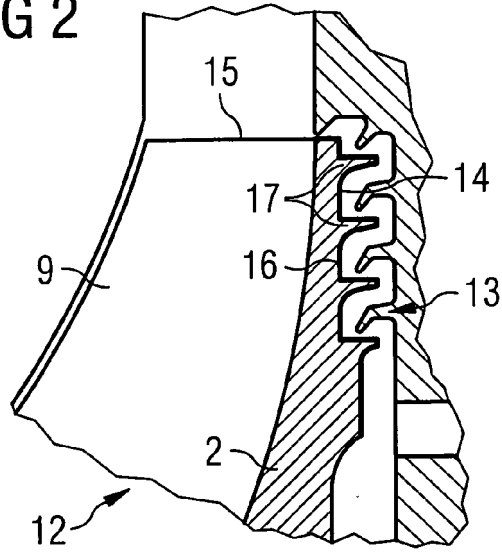

FIG 3

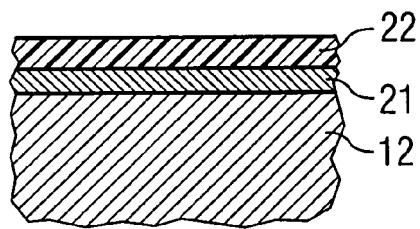
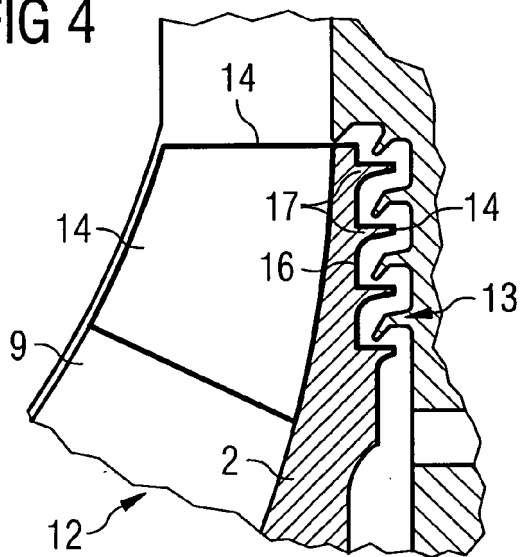

FIG 4





DOCUMENTS CONSIDERED TO BE RELEVANT			
Category	Citation of document with indication, where appropriate, of relevant passages	Relevant to claim	CLASSIFICATION OF THE APPLICATION (IPC)
X	US 6 155 780 A (ROUSE GREGORY C [US]) 5 December 2000 (2000-12-05) * the whole document *	1-4	INV. F01D5/04 F04D29/02 F04D29/28
X	----- US 2004/197212 A1 (ROBY STEVE [US]) 7 October 2004 (2004-10-07) * the whole document *	1-4	
X	----- DE 42 39 391 A1 (ELECTRO CHEM ENG GMBH [CH]) 9 June 1993 (1993-06-09) * the whole document *	1	
X	----- FR 2 451 997 A1 (MOTOREN TURBINEN UNION [DE]) 17 October 1980 (1980-10-17) * the whole document *	1	
A	----- WO 2006/126993 A (HONEYWELL INT INC [US]; RENAUD PHILLIPPE M [FR]; WILSON MARC J [FR]) 30 November 2006 (2006-11-30) * the whole document *	1	
The present search report has been drawn up for all claims			TECHNICAL FIELDS SEARCHED (IPC)
			F01D F04D
Place of search		Date of completion of the search	Examiner
Munich		18 September 2007	Giorgini, Gabriele
CATEGORY OF CITED DOCUMENTS		T : theory or principle underlying the invention E : earlier patent document, but published on, or after the filing date D : document cited in the application L : document cited for other reasons & : member of the same patent family, corresponding document	
X : particularly relevant if taken alone Y : particularly relevant if combined with another document of the same category A : technological background O : non-written disclosure P : intermediate document			

1
EPO FORM 1503 03 82 (P04C01)

**ANNEX TO THE EUROPEAN SEARCH REPORT
ON EUROPEAN PATENT APPLICATION NO.**

EP 07 00 8235

This annex lists the patent family members relating to the patent documents cited in the above-mentioned European search report. The members are as contained in the European Patent Office EDP file on
The European Patent Office is in no way liable for these particulars which are merely given for the purpose of information.

18-09-2007

Patent document cited in search report		Publication date	Patent family member(s)	Publication date
US 6155780	A	05-12-2000	NONE	

US 2004197212	A1	07-10-2004	NONE	

DE 4239391	A1	09-06-1993	CH 690174 A5	31-05-2000
			JP 5261852 A	12-10-1993
			US 5487825 A	30-01-1996

FR 2451997	A1	17-10-1980	DE 2910932 A1	25-09-1980
			JP 55128603 A	04-10-1980

WO 2006126993	A	30-11-2006	NONE	

REFERENCES CITED IN THE DESCRIPTION

This list of references cited by the applicant is for the reader's convenience only. It does not form part of the European patent document. Even though great care has been taken in compiling the references, errors or omissions cannot be excluded and the EPO disclaims all liability in this regard.

Patent documents cited in the description

- US 4277222 A [0006] [0019]