

(19)



(11)

EP 2 003 626 A1

(12)

EUROPEAN PATENT APPLICATION

(43) Date of publication:
17.12.2008 Bulletin 2008/51

(51) Int Cl.:
G07F 11/42 (2006.01)

(21) Application number: **07425292.5**

(22) Date of filing: **21.05.2007**

(84) Designated Contracting States:
**AT BE BG CH CY CZ DE DK EE ES FI FR GB GR
 HU IE IS IT LI LT LU LV MC MT NL PL PT RO SE
 SI SK TR**
 Designated Extension States:
AL BA HR MK RS

(71) Applicant: **F.A.S. International S.p.A.**
36015 Schio (Vicenza) (IT)

(72) Inventor: **Ribello, Angelo**
36034 Malo (VI) (IT)

(74) Representative: **Perani, Aurelio et al**
Perani Mezzanotte & Partners
Piazza San Babila, 5
20122 Milano (IT)

(54) **Safety mechanism for refrigerated vending machine**

(57) The present invention concerns a refrigerated vending machine 1, for example for food products, comprising a locking member 62 and an actuator 61 operati-

tionally associated with the front panel 4 and with the trays 5 of the vending machine 1 so as to prevent, when the front panel 4 is closed, the trays 5 from sliding towards it and damaging it.

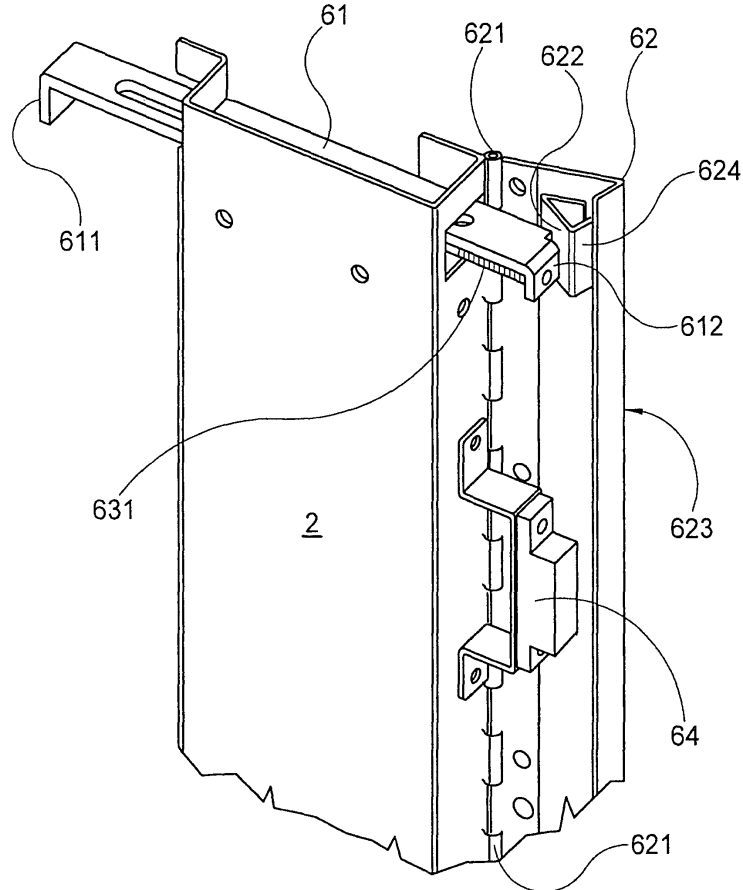

FIG.2

EP 2 003 626 A1

Description

[0001] The present invention relates to a safety mechanism for a refrigerated vending machine.

[0002] Refrigerated vending machines are generally composed of a frame having, formed inside it, a space which is open at the front, for storing the products to be dispensed, which are usually arranged on support trays equipped with selective dispensing means known in the art.

[0003] The front opening of the vending machine is closed by a front panel, generally comprising a sheet of glass or transparent material arranged in a surrounding support rim; the front panel may be hinged on the frame so that it can be easily opened in order to replenish the vending machine.

[0004] Usually dispensing of the product is performed by means of gravity, namely the selected product is pushed beyond the front edge of the tray and is allowed to fall, through the gap present between the trays and the front panel, into a receiving space which can be accessed by the users.

[0005] In order to facilitate replenishing of the vending machine and loading of the products on the trays, the latter are usually arranged on slides which allow displacement thereof outwards so that, when the front panel is open, it is possible to selectively extract the trays in order to replenish them with products.

[0006] During transportation of the vending machine from the manufacturer to the distributor and to the location for end use, the vending machines are subject to vibrations and mechanical stresses which push the trays out of their normal working position. It may therefore happen that these stresses push the trays against the transparent part of the front panel, damaging it.

[0007] This problem is of particular concern only during transportation since, during operation, the machines are arranged level and are usually not subject to high mechanical stresses.

[0008] For these reasons, in order to prevent accidental damage to the front panel following an unexpected movement of the trays against it, it is customary to arrange between the outer edge of the trays and the inner edge of the front panel a layer of soft material, for example a sheet of expanded polystyrene able to dampen the impacts or prevent unwanted movements of the trays.

[0009] The use of an intermediate sheet, however, involves having to dispose of the sheet at the time of installation. Since installation is usually performed in offices or in public places, it would be desirable to provide a safety device incorporated in the vending machine itself.

[0010] In view of the state of the art described, the object of the present invention is to provide a vending machine in which the risk of damage to the front closing panel is lower than in the vending machines known in the art.

[0011] In accordance with the present invention, this object is achieved by means of a vending machine in

accordance with Claim 1.

[0012] The characteristic features and advantages of the present invention will become clear from the following detailed description of a practical embodiment provided by way of a non-limiting example with reference to the accompanying drawings in which:

- Figure 1 shows a partial perspective view of a portion of a vending machine comprising safety means according to the present invention;
- Figure 2 shows a partial perspective view of a preferred embodiment of the safety means according to the present invention;
- Figure 3 shows a top plan view of a second preferred embodiment of the safety means according to the present invention;
- Figure 4 shows a top plan view of a third preferred embodiment of the safety means according to the present invention;
- Figure 5 shows a schematic view, from above, of a refrigerated vending machine, in the closed condition, comprising the safety means according to the present invention;
- Figure 6 shows a schematic top plan view of the vending machine according to Figure 5, in the semi-open condition with locking of the trays;
- Figure 7 shows a schematic top plan view of the vending machine according to Figure 5, in the semi-open condition without locking of the trays;
- Figure 8 shows a schematic top plan view of the vending machine according to Figure 5, in the open condition, with the trays partially extracted;
- Figure 9 shows a schematic top plan view of the vending machine according to Figure 5, in the semi-closed condition, with the trays partially retracted.

[0013] The figures show a refrigerated vending machine 1 comprising a frame 2 which defines a space 3 for storing the products to be dispensed and a front opening for access to this space 3; the front opening can be closed by a front panel 4 (visible solely in Figures 5 to 9) arranged movably relative to the frame 2.

[0014] The front panel 4 is usually transparent so as to allow a user to see what is arranged inside the space 3.

[0015] Inside the space 3 the vending machine 1 comprises one or more trays 5 which are usually rectangular or circular and in which a plurality of movable compartments 51 for housing the products to be dispensed are defined. The movement of the compartments 51 in order to deliver to the user the prechosen product is achieved by means of systems known in the art, for example by means of a spiral device, such as that shown in the figures, which therefore will not be further described.

[0016] The vending machine 1 comprises one or more trays 5 sliding between an inner position and an outer position, a front panel 4 movable between a closed position and an open position, an actuator 61 movable between an outer position and an inner position and a lock-

ing member 62 movable between a first position and a second position, all being operationally associated with each other so that, when the front panel 4 is in the closed position, the trays 5 are forced to remain in the outer position, effectively preventing the trays 5 from damaging the front panel 4 itself.

[0017] During the course of the present description, reference will be made to "positions" between which the parts kinematically linked together (i.e. front panel 4, actuator 61, locking member 62, trays 5) are movable, a particular technical effect being associated with each reference position.

[0018] These reference positions do not represent just a single physical point, but also a section (in some cases angular) of the travel path of each part, the length of which will depend on the characteristics of the vending machine 1 on which these parts will be provided in practice.

[0019] Since, for each part, the technical effects associated with the reference positions are mutually exclusive, the sections of the travel paths must not overlap each other. The locking member 62 is movable between a first position, where it has a constraining action which prevents the movement of the trays 5 from the inner position to the outer position, and a second position, where it has a constraining action preventing the movement of the actuator 61 into the outer position.

[0020] The trays 5 are movable between an inner position corresponding to the position assumed during normal use of the vending machine, where they allow the movement of the locking member 62 from the second position into the first position, and an outer position, complementary thereto, where they have a constraining action which prevents the locking member 62 from moving from the second position into the first position; an example of this position is that where the trays 5 project outwards from the space 3.

[0021] The actuator 61 is movable between an outer position, where it allows the movement of the locking member 62 from the first position into the second position, and an inner position, complementary thereto, where it has a constraining action which prevents the locking member 62 from moving from the first position into the second position.

[0022] The front panel 4 is movable between a closed position, where it has a constraining action which prevents the actuator 61 from moving from the inner position into the outer position, and an open position, where it does not constrain the actuator 61 in any position.

[0023] The locking member 62 therefore acts as a device for "switching" between the movement of the trays 5 and the movement of the actuator 61, preventing the trays 5 from assuming the outer position and the actuator 61 from assuming the inner position simultaneously.

[0024] This constraining action prevents the movement of the trays 5 into the outer position when the front panel 4 is closed and, advantageously, also prevents closing of the front panel 4 when the trays 5 are in the outer position. When the trays 5 are in the inner position

and the actuator 61 is in the outer position, the locking member 62 is able to move from the first position into the second position and vice versa.

[0025] The movement of the locking member 62 from the second position into the first position may advantageously be performed by means of the action of the actuator 61; the reverse movement may advantageously be performed only by means of the action of an external operator. In this way greater control of the moment when the trays 5 are released is ensured; at the same time, closing of the front panel 4 may be performed only if the trays 5, advantageously only if all the trays 5, are in their inner position.

[0026] The actuator 61 advantageously projects from the frame 2, namely when it is in the outer position it occupies part of the space which is occupied by the front panel 4 when the latter is in the closed position.

[0027] The outer end 611 of the actuator 61 may come into contact with the front panel 4; its inner end 612, which is advantageously situated inside the frame 2 and/or the space 3, may come into contact with the locking member 62.

[0028] In the practical embodiment shown in the figures, the actuator 61 is substantially straight, being arranged horizontally and/or is able to be displaced along its longitudinal axis.

[0029] Advantageously, the axis of displacement of the actuator 61 is parallel to the axis of displacement of the trays 5.

[0030] The locking member 62 comprises a first actuating surface 622, which receives the thrusting force of the actuator 61 so as to move from the second position into the first position, and a stop surface 623, which acts as an abutting surface for a corresponding stop surface 53 provided on the trays 5, so as to keep the trays 5 in the inner position.

[0031] In the embodiment shown in the figures, the locking member 62 is formed by a section bar, which is advantageously hinged about a pin 621, for example defining a vertical axis, and the actuating surface 622 converts the translatory movement of the actuator 61 into a rotational movement about the pin 621.

[0032] In the example shown in the figures, the section bar 62 is in the form of an asymmetrical V, with one of the sides of the V (preferably the long side) which performs the function of a rotating arm and the other of the sides of the V which comprises the stop surface 623.

[0033] In the preferred embodiments according to Figures 3 and 4, the end of the side which is not hinged comprises the actuating surface 622, which receives the thrusting force from the inner end 612 of the actuator 61; however, it is also possible to form the actuating surface 622 as a separate part 624 (see Figure 2).

[0034] Advantageously, the section bar 62 may be formed by folding a metal plate of suitable size.

[0035] The surface 55 of the trays 5 which is directed towards the locking member 62 is that which prevents the locking member from moving into the first position,

since it acts against a corresponding stop surface 625 of the locking member 62.

[0036] The stop surface 53 advantageously coincides with the edge of the trays 5, directed towards the front panel 4. Alternatively, the surface 53 may be one of the two sides of a seat formed in the vicinity of the corner of the trays 5 situated close to the locking member 62. In this case, the surface 55 may be formed on the other side of this seat.

[0037] The vending machine may comprise resilient recall means acting on the actuator 61 so as to keep it in the outer position, for example a coil spring 631 (visible in Figure 3) and/or resilient recall means acting on the locking member 62 so as to keep it in the first position, for example a leaf spring 632 (visible in Figure 4).

[0038] In this case, it is possible to envisage suitable means (not shown) for limiting the travel movement of the section outwards, under the thrust of the leaf spring 632.

[0039] Furthermore, it is possible to envisage retaining means 64 which are able to releasably retain the locking member 62 in the second position, once this position has been reached. These retaining means 64 may be formed, for example, by one or more magnets or electromagnets, although other methods (e.g. a double strip of material with small hooks and loops, such as Velcro®) are possible.

[0040] The retaining means 64 are advantageously stronger than the recall means mounted on the locking member 62, but only when in a close position.

[0041] With reference to Figures 5 to 9, the operating principle of the vending machine 1 according to the invention is described.

[0042] When the vending machine 1 is in the configuration according to Figure 5, the front panel 4 is closed, the actuator 61 is in the inner position, the locking member 62 is in the first position and the trays 5 are in the inner position. The trays 5 are unable to move into the outer position, and therefore damage to the front panel 4 is prevented.

[0043] After opening of the front panel 4, the situation shown in Figure 6 exists: the front panel 4 is now in an open position since the locking member 62 can move from the first position into the second position. The actuator 61, pushed by its resilient recall means 631, is in fact still in contact with the front panel 4, but is now in an outer position.

[0044] At this point, an operator is able to operate the locking member 62 and move it, overcoming the force of the recall means 632, from the first position into the second position, and fix it to the retaining means 64 in the second position (Figure 7). The trays 5 are able to move from the inner position into the outer position.

[0045] Figure 8 shows the vending machine 1 which is completely open: the front panel 4 is in an open position: the actuator 61 is in an outer position, the locking member 62 is in the second position and the trays 5 are in an outer position.

[0046] Closing of the vending machine is performed by means of the following operations: the trays 5 are brought back into the inner position (visible in Figures 5, 6 and 7) and the front panel 4 is closed. When the front panel reaches a closed position, it presses against the actuator 61, moving it into the inner position. The actuator 61 in turn presses against the locking member 62, moving it into the first position, without the need for manual action.

[0047] Should, however, the trays 5 not be completely inserted in their seats, namely should they be still situated in an outer position, the locking member 62 would not be able to move into the first position, preventing in turn the actuator 61 from moving into the outer position and preventing closing of the outer panel 4. This situation is shown in Figure 9.

[0048] A second problem which may arise with vending machines which have sliding trays 5 occurs when the trays 5, after a product replenishing operation, are not all correctly arranged in their seats. In this case it could happen that a tray 5 which is situated in an outer position may interfere with the trajectory of a product which is falling towards the receiving space. The impact between the falling product and the projecting tray 5 may have undesirable effects such as: damage to the falling product, the product getting caught between the front panel and the projecting tray and/or dispensing of a product, positioned on the projecting tray 5, different from the desired one.

[0049] The vending machine described is able to solve, not only the problem of preventing impacts caused by the trays 5 against the front panel 4, but this problem as well.

[0050] In the example of embodiment shown in the figures, when the actuator 61 pushes the section bar from the second position into the first position, the leaf spring 632 causes the section bar itself to snap into the second position, as soon as the combined action of the actuator 61 and of the leaf spring 632 manages to overcome the force of the retaining element 64.

[0051] Advantageously, the vending machine 1 comprises an actuator 61 for each locking member 62 and a locking member 62 for one only, for some or, preferably, for all the trays 5; it is possible to envisage, moreover, an independent locking member 62 for each tray 5 or, as can be seen in the figures, a locking member 62 having a length such that it is able to constrain all the trays 5 at the same time. Preferably a configuration will be adopted such as to prevent closing of the front panel 4 also even if only one of the trays 5 is in the outer position.

[0052] In a preferred embodiment, the front panel 4 is hinged on one of the sides of the vending machine 1, advantageously on the side opposite to the side containing the product selection electronics, and the actuator 61 and the locking member 62 are arranged in the vicinity of the front opening, on the opposite side; however, it is conceivable to arrange these parts also on the same side on which the front panel 4 is hinged, using, if necessary, for the actuator 61 a rotating part which acts against a

suitable cam, or other devices for converting the movement of the front panel 4 into a movement of the locking member 62.

[0053] The vending machine 1 comprises generally also devices for selecting the product, for collecting the money, for monitoring correct operation, for refrigerating the products, and other devices.

[0054] Obviously, a person skilled in the art, in order to meet unforeseen and specific requirements, may make numerous modifications and variations to the configurations described above, all of which moreover are contained within the scope of protection of the invention as defined by the following claims.

Claims

1. Vending machine (1) for dispensing products, comprising:

- a frame (2) provided with a front opening and defining inside it a storage space (3);
- one or more trays (5) able to receive said products and slidably supported in the frame (2) between an inner position, corresponding to the position for normal use, and an outer position;
- a front panel (4) movably supported by said frame (2) between a closed position, where it closes said front opening, and an open position, where it allows access to the storage space (3) through the front opening;

characterized in that it comprises:

- a locking member (62) operationally associated with said trays (5) and movable between a first position, where it prevents the trays (5) from moving into the outer position, and a second position, where it allows the trays (5) to move into the outer position;
- an actuator (61) operationally associated with said locking member (62) and said front panel (4); said actuator (61) being movable between an inner position, where it prevents the locking member (62) from moving into the second position, and an outer position, where it does not prevent the locking member (62) from moving into the second position.

2. Vending machine (1) according to the preceding claim, in which said one or more trays (5) in said outer position have a constraining action which prevents said locking member (62) from moving into said first position so as to prevent said actuator (61) from moving into said inner position.

3. Vending machine (1) according to any one of the preceding claims, in which said front panel (4) in the

closed position has a constraining action which prevents said actuator (61) from moving into said outer position.

4. Vending machine (1) according to any one of the preceding claims, in which said actuator (61) in the outer position has a constraining action which prevents said front panel (4) from moving into said closed position.

5. Vending machine (1) according to any one of the preceding claims, comprising recall means (631) acting on the actuator (61) so as to keep it in the outer position.

6. Vending machine (1) according to any one of the preceding claims, in which the actuator (61) is substantially straight and may move in its longitudinal direction between said inner and outer positions.

7. Vending machine (1) according to any one of the preceding claims, in which said actuator (61) in the outer position occupies part of the space occupied by said front panel (4) in the closed position.

8. Vending machine (1) according to any one of the preceding claims, comprising recall means (631) acting on the locking member (61) so as to keep it in the first position.

9. Vending machine (1) according to any one of the preceding claims, comprising retaining means (64) able to releasably retain the locking member (61) in the second position.

10. Vending machine (1) according to any one of the preceding claims, in which the locking member (61) is a section bar (62) which is hinged on the frame (2) in the vicinity of said front opening along a vertical axis.

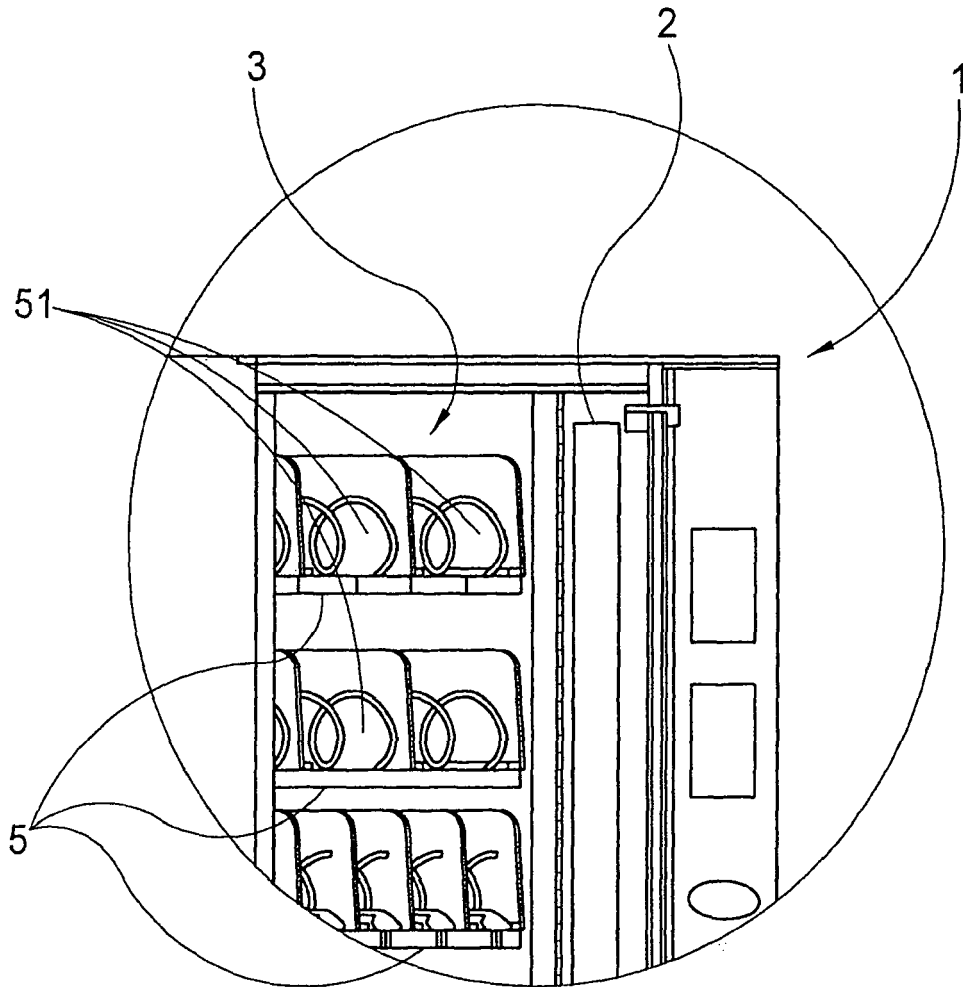

FIG. 1

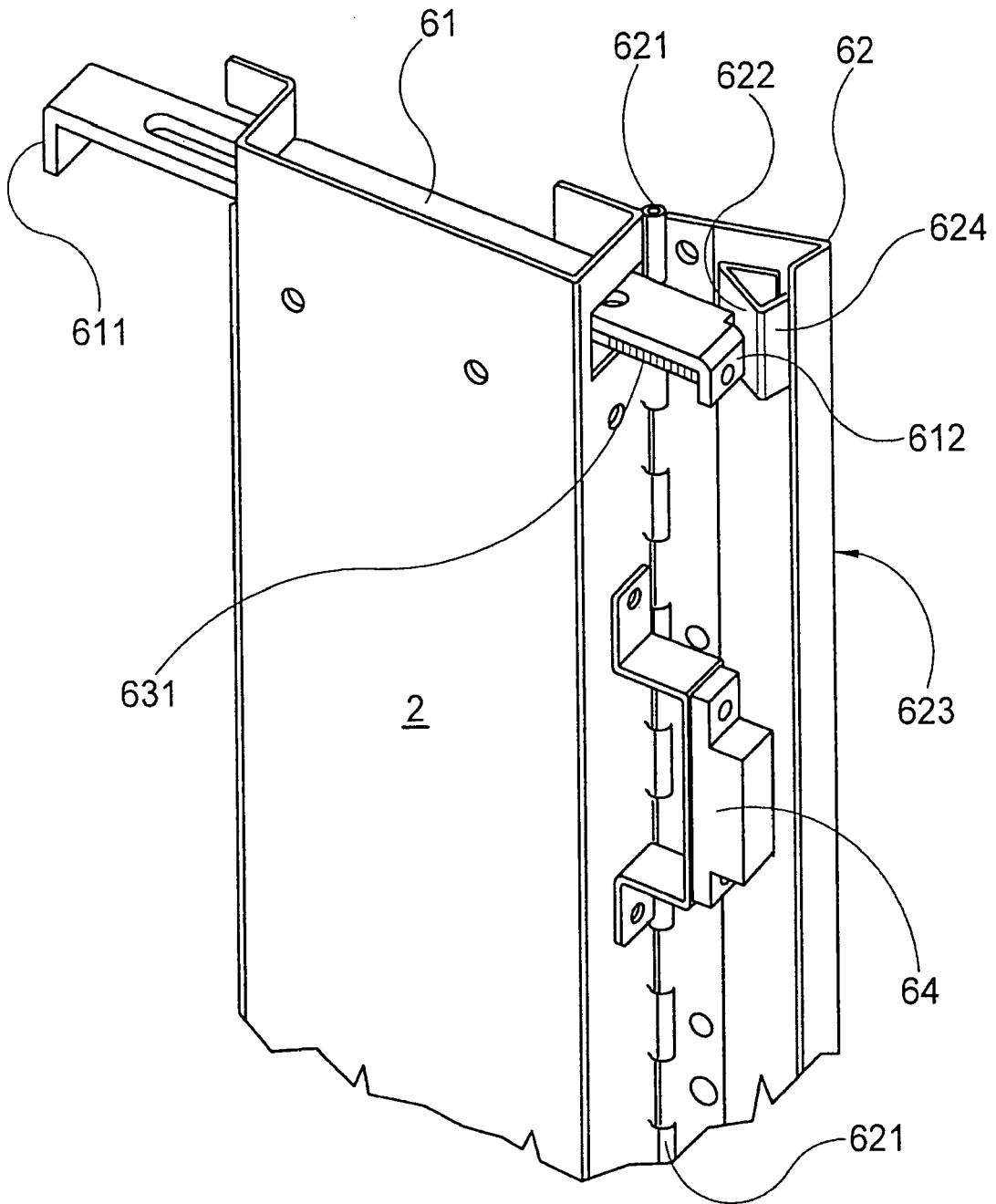

FIG. 2

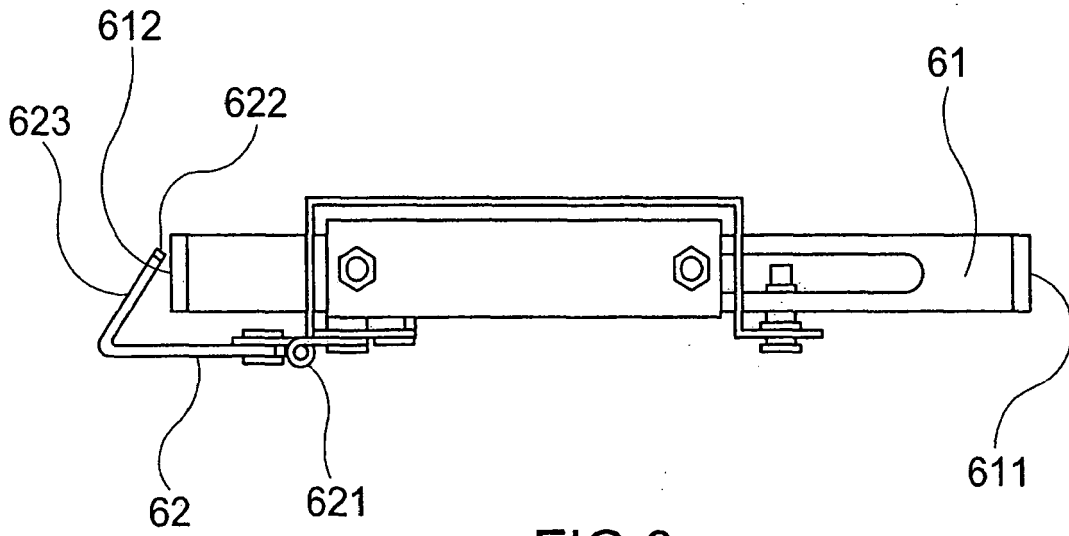

FIG.3

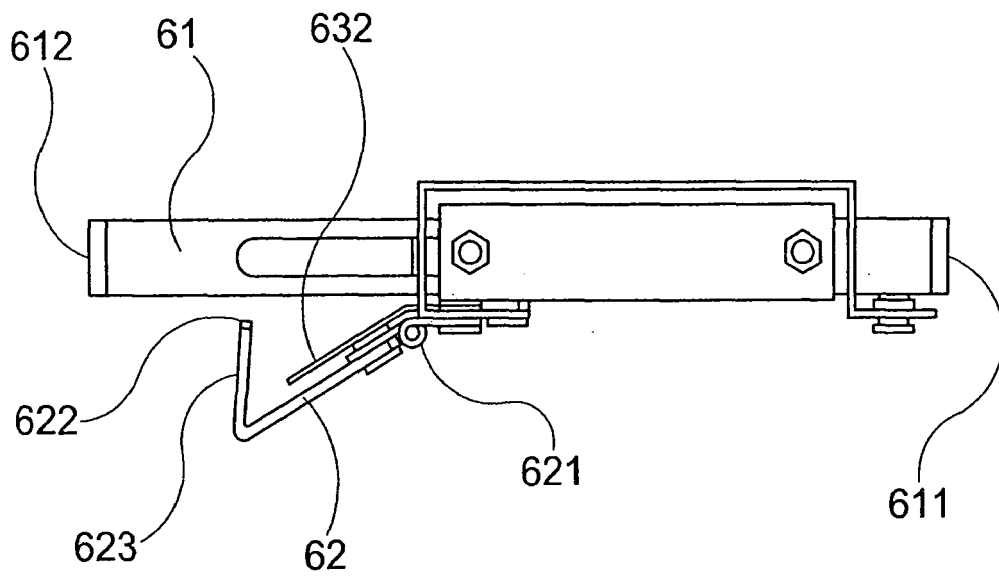

FIG.4

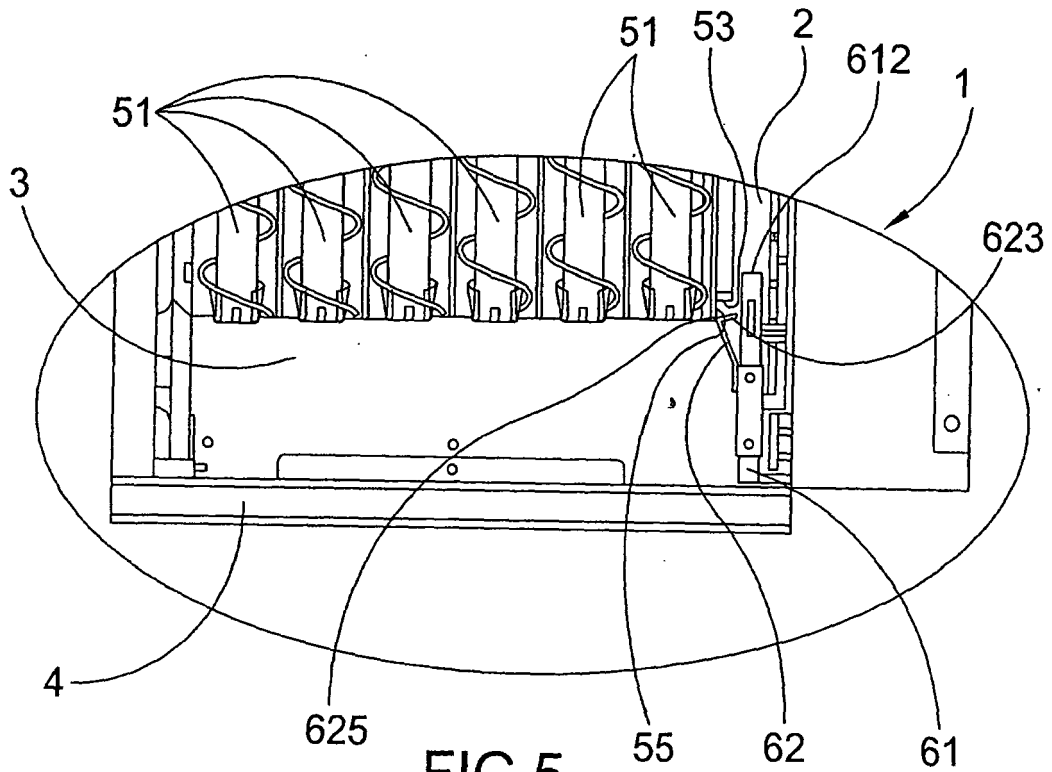

FIG. 5

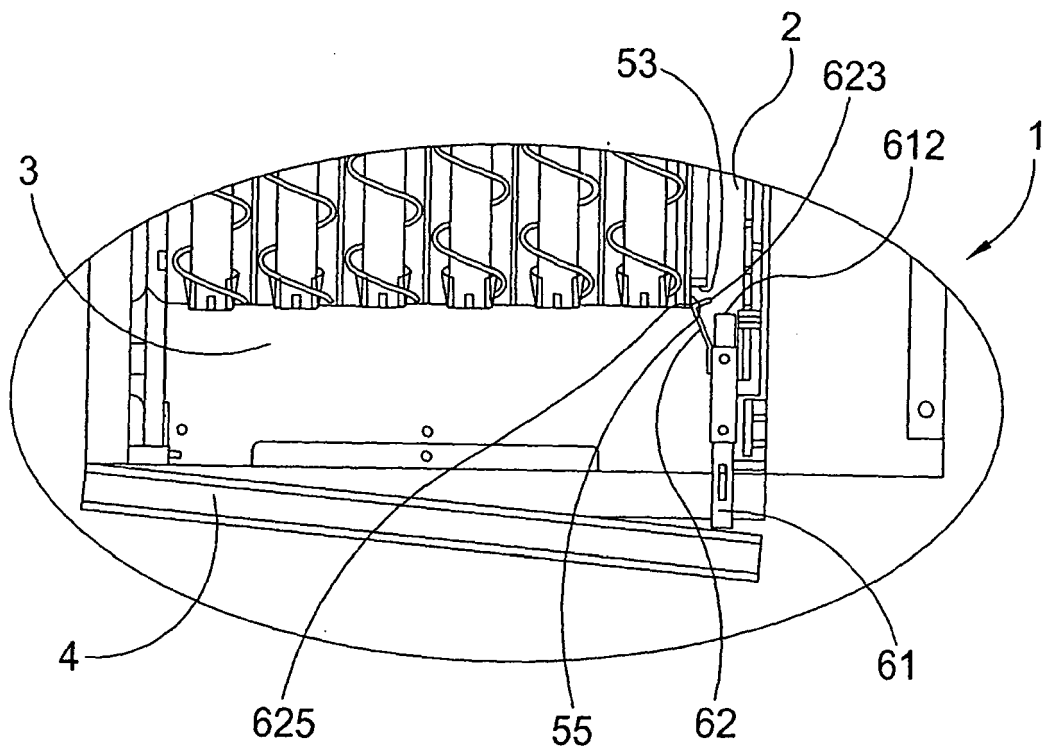

FIG. 6

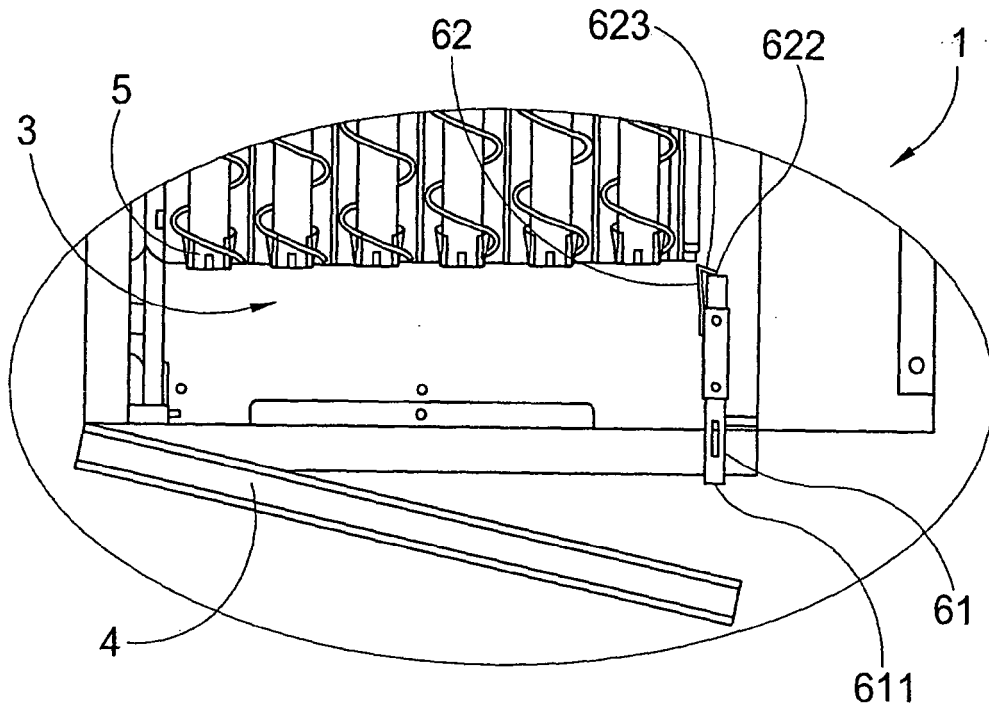

FIG. 7

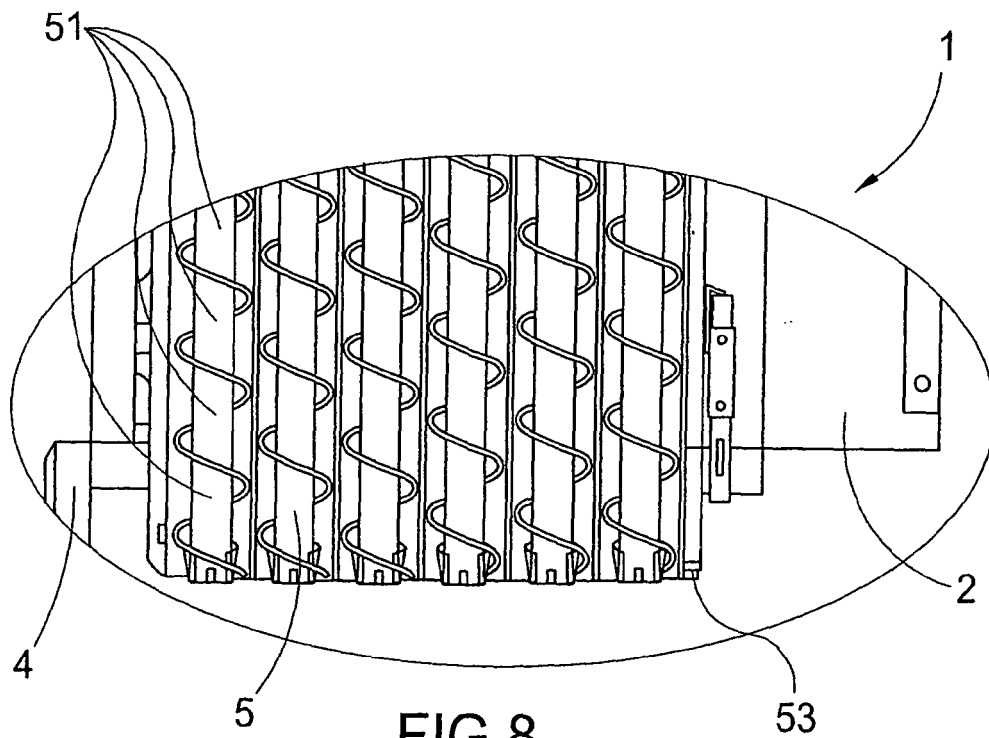

FIG. 8

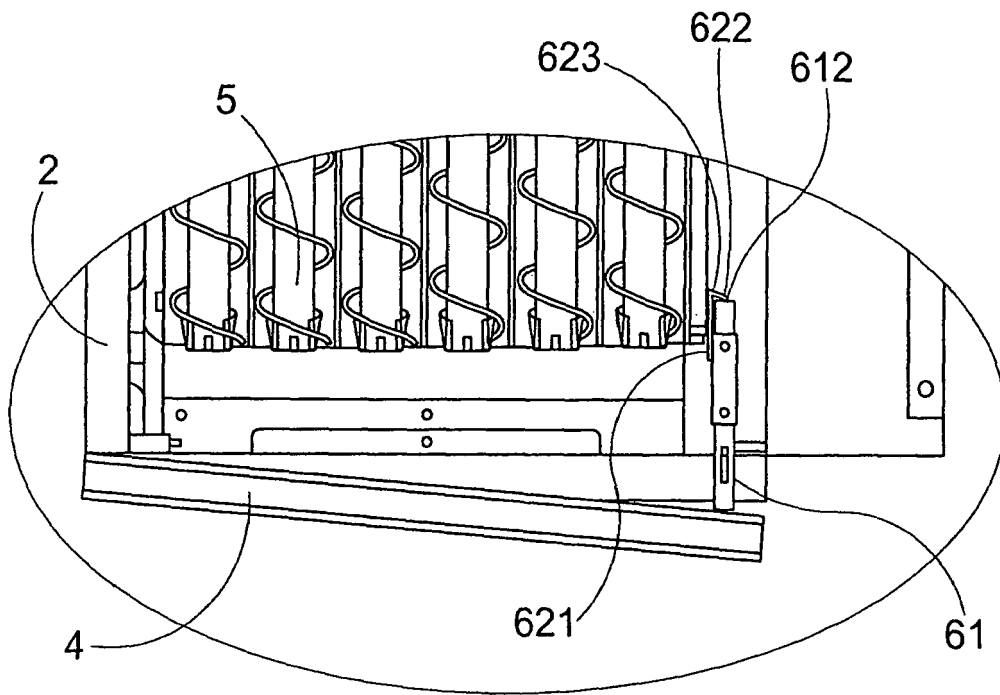

FIG.9



DOCUMENTS CONSIDERED TO BE RELEVANT			
Category	Citation of document with indication, where appropriate, of relevant passages	Relevant to claim	CLASSIFICATION OF THE APPLICATION (IPC)
X	US 4 046 440 A (COX ROBERT N ET AL) 6 September 1977 (1977-09-06) * column 1, line 34 - column 2, line 10 * * column 3, line 11 - column 5, line 54 * * column 2, line 50, paragraph 57 * * column 4, line 44, paragraph 57; figures 1-5 *	1-10	INV. G07F11/42
X	----- US 4 209 211 A (ALFORD JAMES R [US]) 24 June 1980 (1980-06-24) * figures 2-7 * * column 1, line 23 - column 2, line 21 * * column 3, line 10 - column 6, line 9 *	1-10	
A	----- US 4 023 704 A (PITEL IRVING ET AL) 17 May 1977 (1977-05-17) * column 3, line 27 - line 45; figure 2 * reference 88 in fig. 2	1,6	
A	----- US 4 138 174 A (COX ROBERT N ET AL) 6 February 1979 (1979-02-06) * column 1, line 24 - column 2, line 68; figures 5-9 * * column 3, line 55 - column 4, line 27 * -----	1	
The present search report has been drawn up for all claims			TECHNICAL FIELDS SEARCHED (IPC) G07F
Place of search The Hague		Date of completion of the search 14 November 2007	Examiner Guivol, Ouri
CATEGORY OF CITED DOCUMENTS X : particularly relevant if taken alone Y : particularly relevant if combined with another document of the same category A : technological background O : non-written disclosure P : intermediate document		T : theory or principle underlying the invention E : earlier patent document, but published on, or after the filing date D : document cited in the application L : document cited for other reasons & : member of the same patent family, corresponding document	

2
EPC FORM 1503 03.02 (P04C01)

ANNEX TO THE EUROPEAN SEARCH REPORT
ON EUROPEAN PATENT APPLICATION NO.

EP 07 42 5292

This annex lists the patent family members relating to the patent documents cited in the above-mentioned European search report. The members are as contained in the European Patent Office EDP file on The European Patent Office is in no way liable for these particulars which are merely given for the purpose of information.

14-11-2007

Patent document cited in search report		Publication date	Patent family member(s)	Publication date
US 4046440	A	06-09-1977	NONE	

US 4209211	A	24-06-1980	CA 1123396 A1	11-05-1982
			JP 55047595 A	04-04-1980

US 4023704	A	17-05-1977	CA 1014529 A1	26-07-1977
			FR 2266231 A1	24-10-1975
			GB 1498525 A	18-01-1978
			JP 1228523 C	19-09-1984
			JP 50134500 A	24-10-1975
			JP 59003797 B	26-01-1984

US 4138174	A	06-02-1979	NONE	
