



(11) **EP 2 019 058 A8**

(12) **CORRECTED EUROPEAN PATENT APPLICATION**

(15) Correction information:
Corrected version no 1 (W1 A2)
Bibliography INID code(s) 72

(51) Int Cl.:
B65H 1/04 (2006.01) B65H 9/00 (2006.01)

(48) Corrigendum issued on:
18.03.2009 Bulletin 2009/12

(43) Date of publication:
28.01.2009 Bulletin 2009/05

(21) Application number: **08075667.9**

(22) Date of filing: **26.07.2008**

(84) Designated Contracting States:
AT BE BG CH CY CZ DE DK EE ES FI FR GB GR HR HU IE IS IT LI LT LU LV MC MT NL NO PL PT RO SE SI SK TR
Designated Extension States:
AL BA MK RS

(71) Applicant: **Komori Corporation**
Sumida-ku
Tokyo (JP)

(72) Inventor: **Saito, Nobuaki**
c/o Tsukuba Plant, Komori Corporation
Tsukuba-shi, Ibaraki (JP)

(30) Priority: **27.07.2007 JP 2007195585**

(74) Representative: **Wenzel & Kalkoff**
Grubes Allee 26
22143 Hamburg (DE)

(54) **Position adjusting method and apparatus for adjustment target portion in sheet processing machine**

(57) In a position adjusting method for an adjustment target portion in a sheet processing machine including a pile board (301,401) which is lifted and lowered with a sheet stacked thereon, and the adjustment target portion (61-66), a position of which is adjusted in accordance with a size of the sheet on the pile board, the pile board is lifted with the sheet stacked thereon, and the adjustment target portion is moved in a direction to further separate from a center of the sheet on the pile board as the pile board is lifted. A position adjusting apparatus (100) is also disclosed.

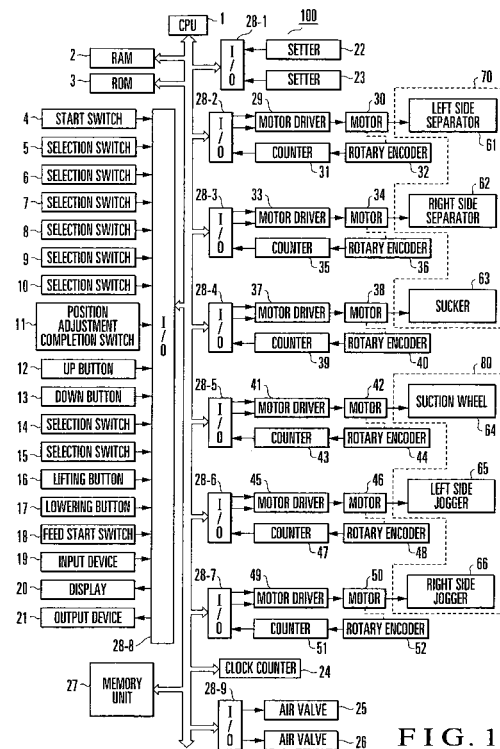

FIG. 1

EP 2 019 058 A8