



(11) **EP 2 022 351 B1**

(12) **EUROPEAN PATENT SPECIFICATION**

(45) Date of publication and mention of the grant of the patent:
25.04.2012 Bulletin 2012/17

(51) Int Cl.:
A24D 3/02 (2006.01)

(21) Application number: **08161235.0**

(22) Date of filing: **28.07.2008**

(54) **An apparatus for processing at least one strip of filters material in the tobacco industry**

Vorrichtung zur Verarbeitung von mindestens einem Streifen aus Filtermaterialien in der Tabakindustrie

Appareil de traitement d'au moins une bande de matériau à filtres dans l'industrie du tabac

(84) Designated Contracting States:
DE FR GB NL PL

• **Balletti, Leonardo**
40068 San Lazzaro di Savena (Bologna) (IT)

(30) Priority: **07.08.2007 IT BO20070569**

(74) Representative: **Bianciardi, Ezio et al**
Bugnion S.p.A.
Via di Corticella, 87
40128 Bologna (IT)

(43) Date of publication of application:
11.02.2009 Bulletin 2009/07

(73) Proprietor: **G.D S.p.A.**
40133 Bologna (IT)

(56) References cited:
EP-A1- 0 941 673 EP-A1- 1 692 957
EP-A2- 0 654 224 EP-A2- 0 715 816
EP-A2- 1 559 333

(72) Inventors:
• **Eusepi, Ivan**
40013 Castelmaggiore (Bologna) (IT)

EP 2 022 351 B1

Note: Within nine months of the publication of the mention of the grant of the European patent in the European Patent Bulletin, any person may give notice to the European Patent Office of opposition to that patent, in accordance with the Implementing Regulations. Notice of opposition shall not be deemed to have been filed until the opposition fee has been paid. (Art. 99(1) European Patent Convention).

Description

[0001] The present invention relates to an apparatus for processing at least one strip of filter material in the tobacco industry.

[0002] Filter manufacturing machines for smoking products, in particular cigarettes, are fitted with an apparatus for processing a strip of filtering material, for example cellulose acetate, unwound from a bale and fed by drive rollers along a determinate path. At the outlet of this apparatus the strip is fed to a section of a manufacturing machine for the formation of the single cigarette filters.

[0003] The above-mentioned processing comprises, in order, from the upstream end to the downstream end of the above-mentioned path, an operation for the traction or stretching of the strip and an operation for the treatment of the strip by means of additives comprising, for example, a plasticizing material.

[0004] In particular, the above-mentioned operation for stretching (prevalently longitudinal but also transversal) of the strip, is realised by stretching means comprising two pairs of rollers substantially tangential to each other along the above-mentioned path.

[0005] The tangential speed of the rollers defining the downstream pair is greater than the tangential speed of the rollers defining the upstream pair, in order to subject the strip in the section between the two pairs of rollers to a determinate tension.

[0006] The aim of this operation is to render the strip of filtering material more homogeneous longitudinally and transversally and, finally, to enable a production of filters with determinate characteristics which are constant over time.

[0007] An apparatus for producing strips of filter material according to this construction has been disclosed in EP1559333. Such document discloses a succession of stations, operating on an advancing continuous strip of filter tow, which comprises a first station where the filter tow is stretched, a subsequent second station in which the stretched tow is exposed to relaxation, and a subsequent third station in which a plasticizing material is applied to the relaxed filter tow. The stretching and relaxing effect are induced in the continuous tow by means of a succession of couples of rollers rotating a different speeds.

[0008] The stretching means according to the prior art have not been able to provide a uniform tensioning action on the strip, or in other words to subject the single fibres to a tension which tends to straighten them along the longitudinal axis of the strip itself.

[0009] It is also noted that, according to a characteristic of cellulose acetate, when a strip composed of fibres of that material is subject to a determinate tension it tends, following the so-called "blooming" phenomenon, to expand, thereby increasing its thickness.

[0010] Non-uniform stretching results in the production of a strip with a variable thickness and consequently a production of filters having a filtering capacity and a filling

capacity which is non-uniform and variable during the same production cycle. In addition, a non-efficient stretching results in a non-optimum use of the strip unwound from the bale and, consequently, a waste of material.

[0011] The purpose of the present invention is to provide an apparatus for processing at least one strip of filter material which eliminates the above-mentioned shortcomings, and, in particular, stretching means able to produce a more homogeneous and voluminous strip in order to reduce the waste of material.

[0012] According to the present invention an apparatus is provided for the processing of at least one strip of filter material in the tobacco industry, comprising the characteristics according to one or more of the attached claims.

[0013] The present invention is described with reference to the accompanying drawings, which are provided merely by way of example without restricting the scope of the inventive concept, and in which:

- Figure 1 illustrates a schematic front view of a filter manufacturing machine fitted with an apparatus for the processing of at least one strip of filter material realised according to the present invention;
- Figures 2 to 5 illustrate respective variants of the apparatus in Figure 1;
- Figure 2a illustrates schematically and at a larger scale a detail of Figure 2.

[0014] With reference to Figure 1, the numeral 1 denotes in its entirety a filter manufacturing machine for smoking products, in particular for cigarettes.

[0015] The machine 1 comprises an apparatus 2 for processing a strip 3 of filter material, generally cellulose acetate, advanced along a determinate processing path P in the direction indicated by the arrow F.

[0016] The apparatus 2 is placed between a feeder unit 4, comprising a pair of unwinding rollers 5, 6, cooperating together, which engage the strip 3 coming from a bale 7, and a section or unit, schematically shown as block 8, for the formation of single filters for cigarettes from the strip 3. The rollers 5 and 6 may be idle or motorized.

[0017] The apparatus 2 includes, along path P, means for stretching the strip 3, and a unit, schematically shown as block 9, for the treatment of the strip 3 by means of additives comprising, for example, plasticizing material.

[0018] The above-mentioned stretching means, indicated in their entirety with numeral 10, comprise a first unit 11 and a second unit 12 for longitudinal traction of the strip 3, between which a unit 13 is fitted for loosening or relaxing the strip 3.

[0019] The above-mentioned first traction unit 11 comprises a first pair of rollers 14 and 15 cooperating together, motorized by actuator means, not illustrated, with a tangential speed V1 substantially equal to that of the unwinding rollers 5 and 6 and, downstream of them, after

a section t1, a second pair of rollers 16 and 17 cooperating together, motorized by actuator means, not illustrated, with a tangential speed V2 greater than the speed V1 of the first pair of rollers 14 and 15.

[0020] The relaxation unit 13 of the strip 3 comprises the second pair of rollers 16 and 17 in combination with a pair of rollers 18 and 19 cooperating together and distanced from above-mentioned second pair of rollers 16 and 17 by a section t2 and motorized by respective actuator means, not illustrated, at a tangential speed V3 less than the speed V2 of the rollers 16 and 17.

[0021] The second unit 12 for the longitudinal traction of strip 3 comprises a first pair of rollers, consisting of the above-mentioned rollers 18 and 19 and, downstream of them, after a section t3, a second pair of rollers 20 and 21 cooperating together, motorized by actuator means, not illustrated, with a tangential speed V4 greater than the speed V3 of the above-mentioned rollers 18 and 19 of the first pair of the second traction unit.

[0022] As a result of the above, the strip 3 is subject in the section t1 to a longitudinal traction, in the section t2 to a relaxation and in the section t3 to a further longitudinal traction.

[0023] In practice, it has been seen that this double stretching step, interrupted by a relaxation step, enables a uniform tensioning of the fibres making up the strip 3 and, consequently, a uniform blooming of this strip.

[0024] With reference to Figure 2, the apparatus 2 illustrated differs from that of Figure 1 in that the pairs of rollers 14, 15 and 18, 19 are replaced by respective pairs of idle rollers 22, 23 and 24, 25.

[0025] The idle rollers 22, 23 and 24, 25 forming the above-mentioned pairs are maintained in reciprocal contact along the path P by pressing means, not illustrated, for example of the elastic or pneumatic type, in order to exercise a deforming action on the strip 3, as illustrated in Figure 2a, and to constitute means of braking the advance of the strip 3 itself drawn by the downstream rollers. The apparatus 2 illustrated in Figure 3 differs from that of Figure 1 in that along the path P upstream of the first pair of rollers 14 and 15 there is a pair of idle rollers 22, 23 perfectly similar to the rollers 22, 23 of Figure 2, and the rollers 18 and 19 of Figure 1 are replaced by two rollers 26 and 27 equal to the rollers 24 and 25 of Figure 2.

[0026] As a result of the above, before the relaxation at the section t2, the strip 3 is subject to two successive stretching actions by the rollers 14 and 15 rotating at a tangential speed V1 and the rollers 16 and 17 rotating at a tangential speed V2 and defining an additional traction unit denoted with numeral 11'.

[0027] The apparatus 2 illustrated in Figure 4 is deduced from that illustrated in Figure 2, from which it differs solely by the fact that the strip 3 at the outlet from the pair of rollers 20, 21 is subject to a further stretching action by an additional traction unit denoted with numeral 12' and comprising two rollers 28, 29 cooperating together and motorised by actuator means, not illustrated, with a tangential speed V5 greater than the speed V4.

[0028] Lastly, the apparatus 2 illustrated in Figure 5 can be deduced from that illustrated in Figure 3, from which it differs in that the idle rollers 26 and 27 are replaced by respective rollers 30 and 31 motorised by respective actuator means, not illustrated, at a tangential speed V6 with an intermediate value between the tangential speed V2 of the rollers 16, 17 and the speed V4 of the rollers 20, 21.

[0029] Lastly, it is noted that the tangential speed of rotation of the above-mentioned units 11, 11' and 12, 12' for longitudinal traction of the strip 3 have increasing values from upstream to downstream along the path P.

[0030] The present invention includes all the variants according to which at least one intermediate step of stretching or relaxation of the strip 3 is inserted between two initial and final stretching steps of the strip 3.

Claims

1. An apparatus for processing at least one strip of filter material in the tobacco industry, comprising means for stretching (10) the strip (3) and **characterised in that** the stretching means (10) comprise, along a path (P) for the advance and processing of the strip (3), two terminal units for stretching the strip (3) between which is fitted at least one additional intermediate unit for stretching or relaxation of the strip (3).
2. The apparatus according to claim 1, **characterised in that** the stretching means (10) comprise, along the path (P), at least two longitudinal traction units (11, 12) of the strip (3), and a loosening-relaxation unit (13) of the strip (3) placed between the two longitudinal traction units (11, 12).
3. The apparatus according to claim 2, **characterised in that** each of the two longitudinal traction units (11, 12) comprise, respectively from upstream to downstream of the path P, a first pair of rollers (14-15, 22-23; 18-19, 24-25) and a second pair of rollers (16-17; 20-21) substantially tangential to each other, the rollers of the second pair (16-17; 20-21) having a tangential speed greater than that of the first pair (14-15, 22-23; 18-19, 24-25).
4. The apparatus according to claim 3, **characterised in that** the loosening-relaxation unit (13) comprises the second pair of rollers (16-17) and the pair of rollers (18-19; 24-25) fitted downstream of the rollers (16-17), the rollers (18-19; 24-25) having a tangential speed lower than that of the second pair (16-17).
5. The apparatus according to claim 4, **characterised in that** the pair of rollers (24-25) are idle rollers around their axes and braking rollers for the strip (3).
6. The apparatus according to claim 4, **characterised**

in that the pair of rollers (18-19) are motorized rollers.

7. The apparatus according to any of the foregoing claims from 1 to 6, **characterised in that** the stretching means (10) comprise, along the path P, at least two successive units (11, 11') for longitudinal traction of the strip (3) fitted upstream of the loosening unit (13).
8. The apparatus according to any of the foregoing claims from 1 to 7, **characterised in that** the stretching means comprise, along the path P, at least two successive units (12, 12') for longitudinal traction of the strip (3) fitted downstream of the loosening unit (13).
9. The apparatus according to any of the foregoing claims from 1 to 8, **characterised in that** the traction units (11, 11'; 12, 12') have an increasing tangential speed along the path P.

Patentansprüche

1. Vorrichtung zur Verarbeitung von mindestens einem Streifen aus Filtermaterialien in der Tabakindustrie, umfassend Mittel (10) zum Strecken des Streifens (3) und **dadurch gekennzeichnet, dass** die Streckmittel (10) entlang einer Bahn (P) für das Vorrücken und das Verarbeiten des Streifens (3) zwei Einheiten zum Strecken des Streifens (3) umfassen, zwischen denen mindestens eine zusätzliche Zwischeneinheit zum Strecken oder zur Relaxation des Streifens (3) angeordnet ist.
2. Vorrichtung nach Anspruch 1, **dadurch gekennzeichnet, dass** die Streckmittel (10) entlang der Bahn (P) mindestens zwei longitudinale Einheiten (11, 12) zum Ziehen des Streifens (3) und eine Einheit (13) zum Lökern/zur Relaxation des Streifens (3) umfassen, die zwischen den zwei longitudinalen Einheiten (11, 12) zum Ziehen positioniert ist.
3. Vorrichtung nach Anspruch 2, **dadurch gekennzeichnet, dass** jede der zwei longitudinalen Zieheinheiten (11, 12) jeweils der Bahn P vor- und nachgelagert ein erstes Paar Rollen (14-15, 22-23; 18-19, 24-25) und ein zweites Paar Rollen (16-17; 20-21) umfasst, die im Wesentlichen tangential zueinander sind, wobei die Rollen des zweiten Paares (16-17; 20-21) eine Tangentialgeschwindigkeit aufweisen, die größer als die des ersten Paares (14-15, 22-23; 18-19, 24-25) ist.
4. Vorrichtung nach Anspruch 3, **dadurch gekennzeichnet, dass** die Lockerungs-Relaxations-Einheit (13) das zweite Paar Rollen (16-17) und das Paar

Rollen (18-19; 24-25) umfasst, das den Rollen (16-17) nachgelagert angeordnet ist, wobei die Rollen (18-19; 24-25) eine Tangentialgeschwindigkeit aufweisen, die geringer als die des zweiten Paares (16-17) ist.

5. Vorrichtung nach Anspruch 4, **dadurch gekennzeichnet, dass** das Paar Rollen (24-25) Losrollen um ihre Achsen und Bremsrollen für den Streifen (3) sind.
6. Vorrichtung nach Anspruch 4, **dadurch gekennzeichnet, dass** das Paar Rollen (18-19) motorisierte Rollen sind.
7. Vorrichtung nach einem der vorangehenden Ansprüche 1 bis 6, **dadurch gekennzeichnet, dass** die Streckmittel (10) entlang der Bahn P mindestens zwei aufeinanderfolgende Einheiten (11, 11') zum longitudinalen Ziehen des Streifens (3) umfassen, die der Lockerungseinheit (13) vorgelagert angeordnet sind.
8. Vorrichtung nach einem der vorangehenden Ansprüche 1 bis 7, **dadurch gekennzeichnet, dass** die Streckmittel entlang der Bahn P mindestens zwei aufeinanderfolgende Einheiten (12, 12') zum longitudinalen Ziehen des Streifens (3) umfassen, die der Lockerungseinheit (13) nachgelagert angeordnet sind.
9. Vorrichtung nach einem der vorangehenden Ansprüche 1 bis 8, **dadurch gekennzeichnet, dass** die Zieheinheiten (11, 11'; 12, 12') entlang der Bahn P eine ansteigende Tangentialgeschwindigkeit haben.

Revendications

1. Appareil de traitement d'au moins une bande de matériau à filtres dans l'industrie du tabac, comprenant des moyens pour étirer (10) la bande (3), et **caractérisé en ce que** les moyens d'étirage (10) présentent, le long d'un parcours (P) d'acheminement et de traitement de la bande (3), deux unités terminales pour étirer la bande (3) avec, entre elles, au moins une unité intermédiaire supplémentaire pour étirer ou pour détendre la bande (3).
2. Appareil selon la revendication 1, **caractérisé en ce que** les moyens d'étirage (10) comprennent, le long du parcours (P), au moins deux unités de traction longitudinale (11, 12) de la bande (3), et une unité de relâchement-détente (13) de la bande (3) positionnée entre les deux unités de traction longitudinale (11, 12).

3. Appareil selon la revendication 2, **caractérisé en ce que** chacune des deux unités de traction longitudinale (11, 12) comprend, respectivement de l'amont à l'aval du parcours P, une première paire de rouleaux (14-15, 22-23 ; 18-19, 24-25) et une seconde paire de rouleaux (16-17 ; 20-21) essentiellement tangentiels l'un à l'autre, les rouleaux de la seconde paire (16-17 ; 20-21) ayant une vitesse tangentielle supérieure à la vitesse de la première paire (14-15, 22-23 ; 18-19, 24-25). 5
10
4. Appareil selon la revendication 3, **caractérisé en ce que** l'unité de relâchement-détente (13) comprend la seconde paire de rouleaux (16-17) et la paire de rouleaux (18-19 ; 24-25) installés en aval des rouleaux (16-17), les rouleaux (18-19 ; 24-25) ayant une vitesse tangentielle inférieure à la vitesse de la seconde paire (16-17). 15
5. Appareil selon la revendication 4, **caractérisé en ce que** la paire de rouleaux (24-25) sont des rouleaux libres autour de leurs axes et des rouleaux de freinage pour la bande (3). 20
6. Appareil selon la revendication 4, **caractérisé en ce que** la paire de rouleaux (18-19) consiste en des rouleaux motorisés. 25
7. Appareil selon l'une quelconque des revendications précédentes 1 à 6, **caractérisé en ce que** les moyens d'étirage (10) comprennent, le long du parcours P, au moins deux unités consécutives (11, 11') pour la traction longitudinale de la bande (3), situées en amont de l'unité de relâchement (13). 30
35
8. Appareil selon l'une quelconque des revendications précédentes 1 à 7, **caractérisé en ce que** les moyens d'étirage comprennent, le long du parcours P, au moins deux unités consécutives (12, 12') pour la traction longitudinale de la bande (3), situées en aval de l'unité de relâchement (13). 40
9. Appareil selon l'une quelconque des revendications précédentes 1 à 8, **caractérisé en ce que** les unités de traction (11, 11' ; 12, 12') ont une vitesse tangentielle croissante le long du parcours P. 45

50

55

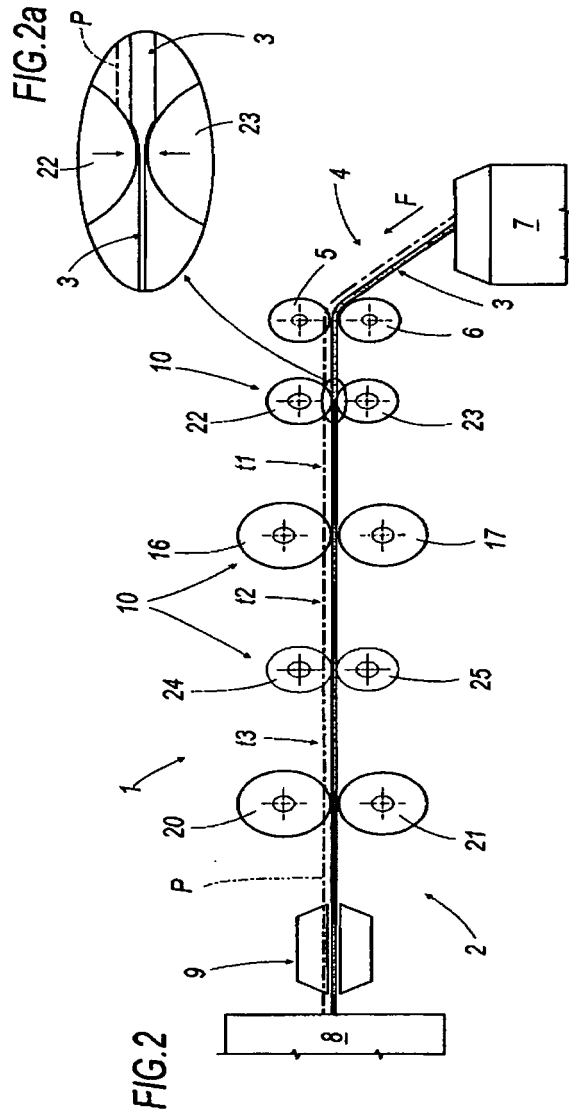
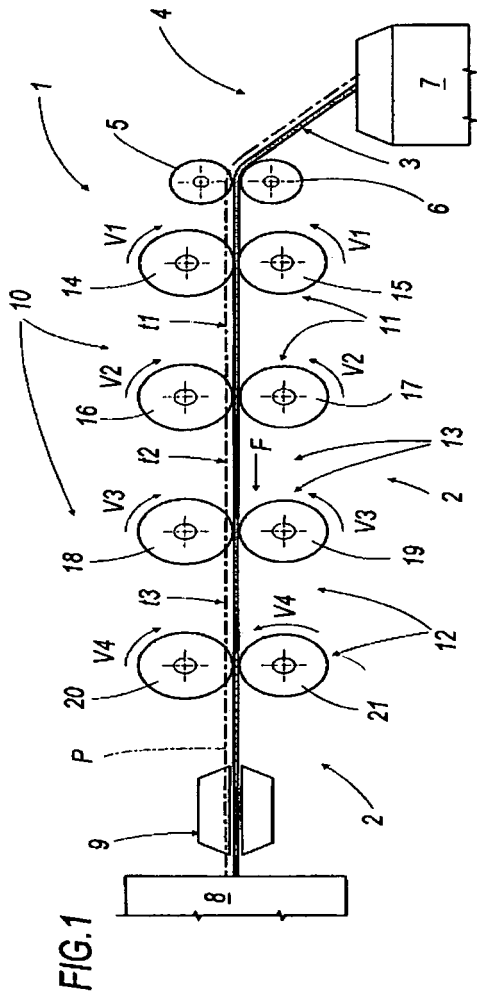

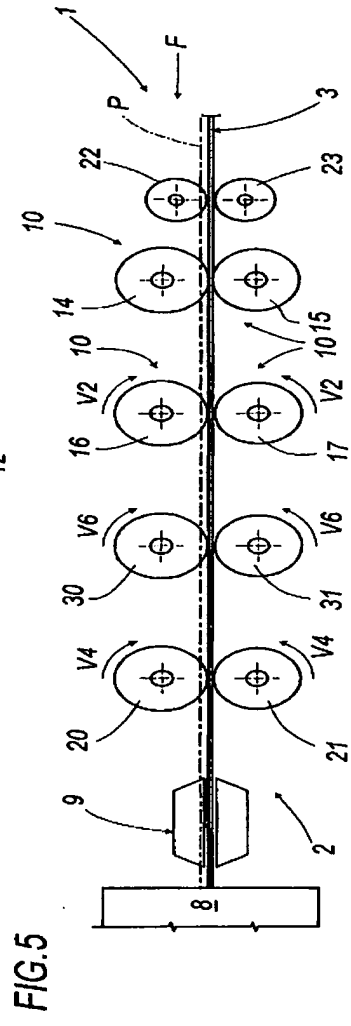
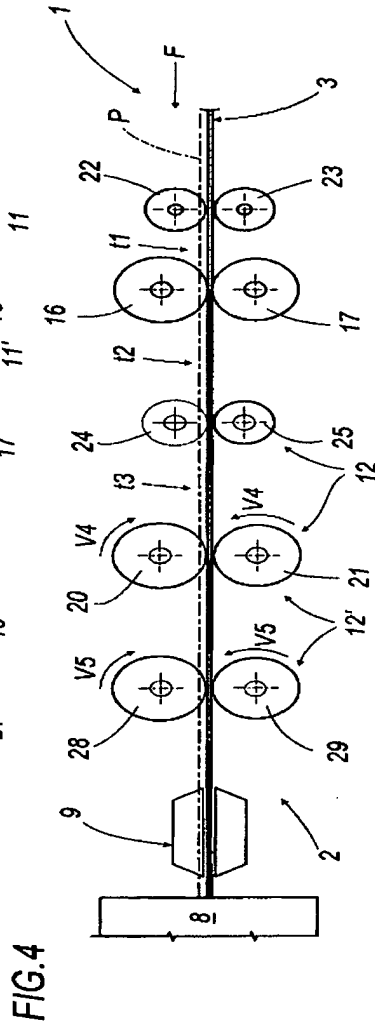
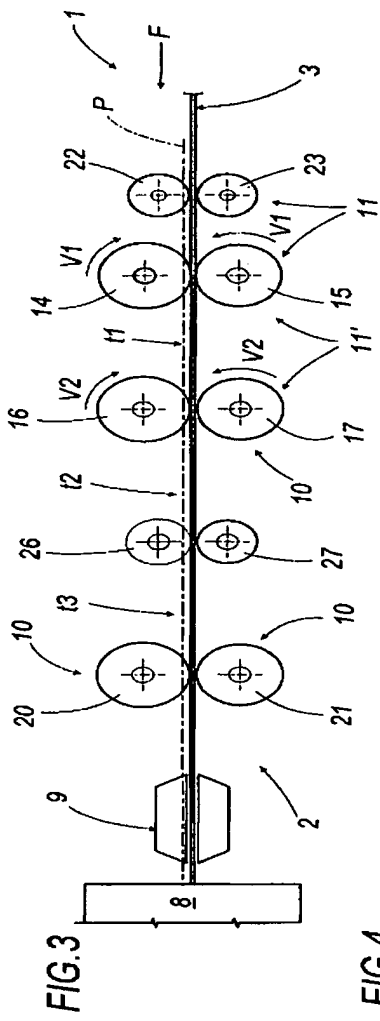

REFERENCES CITED IN THE DESCRIPTION

This list of references cited by the applicant is for the reader's convenience only. It does not form part of the European patent document. Even though great care has been taken in compiling the references, errors or omissions cannot be excluded and the EPO disclaims all liability in this regard.

Patent documents cited in the description

- EP 1559333 A [0007]