



(12) **EUROPEAN PATENT APPLICATION**

(43) Date of publication:
18.02.2009 Bulletin 2009/08

(51) Int Cl.:
H05B 6/06 (2006.01)

(21) Application number: **07016159.1**

(22) Date of filing: **17.08.2007**

(84) Designated Contracting States:
AT BE BG CH CY CZ DE DK EE ES FI FR GB GR HU IE IS IT LI LT LU LV MC MT NL PL PT RO SE SI SK TR
 Designated Extension States:
AL BA HR MK RS

- **Buck, Bernd**
91635 Windelsbach (DE)
- **Echtler, Werner**
90763 Fürth (DE)
- **Leikam, Jürgen**
91161 Hilpoltstein (DE)

(71) Applicant: **Electrolux Home Products Corporation N.V.**
1930 Zaventem (BE)

(74) Representative: **Schröer, Gernot H. et al**
Patentanwälte Meissner, Bolte & Partner
Bankgasse 3
90402 Nürnberg (DE)

(72) Inventors:
 • **Hoffmann, Harald**
91541 Rothenburg ob der Tauber (DE)

(54) **Cooking appliance, especially domestic cooking appliance**

(57) The invention relates to a cooking appliance (1), especially to a domestic cooking appliance, having at least one induction heating element (2, 3, 4, 5) and a control unit (6), wherein the control unit (6) has at least one adjustment knob (7) by which a shaft (8) can be rotated which is connected to an adjustment device (9) for a cooking parameter, which is part of the control unit (6).

To allow an easy use and a good mechanical feedback in adjusting cooking parameters, the invention is characterized in that the adjustment device (9) comprises a resistance element which is connected to an analogue/digital converter (10), wherein the digital signal of the analogue/digital converter (10) is communicating with a control element (11) by means of a bus system (12).

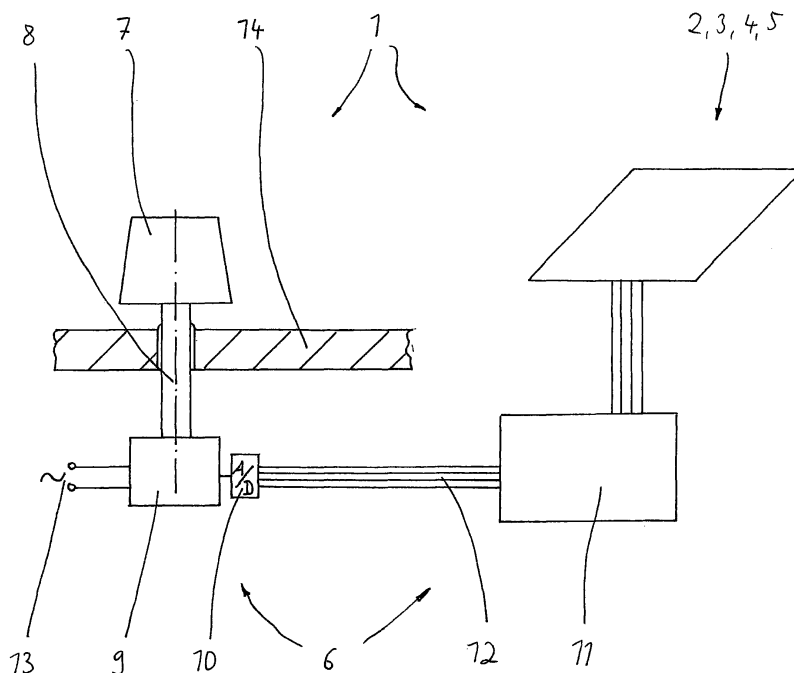

FIG 2

Description

[0001] The invention relates to a cooking appliance, especially to a domestic cooking appliance, having at least one induction heating element and a control unit, wherein the control unit has at least one adjustment knob by which a shaft can be rotated which is connected to an adjustment device for a cooking parameter, which is part of the control unit.

[0002] Cooking appliances of this kind are known. Reference is made to DE 297 01 430 U1. There, an induction hob is disclosed. The heating intensity is adjusted by an adjustment knob which rotates a shaft. The shaft is connected to an adjustment device and regulates the heating intensity of the hob.

[0003] Another well-know design of induction hobs are using a touch electronic or an electronic knob system. Instead of a rotary system there is no mechanical corresponding of the position of the power level of the induction hob.

[0004] Therefore, it is an object of the invention to further develop a cooking appliance, especially a domestic cooking appliance, of the kind mentioned above having at least one induction heating element and at least one adjustment knob by which a shaft can be rotated, so that it allows an easy use and a good mechanical feedback in adjusting cooking parameters. Also, is should become possibly to easy connect the device with the cooperating electronic components to allow an easy assembly and cheap production.

[0005] A solution of this object according to the invention is **characterized in that** the adjustment device comprises a resistance element which is connected to an analogue/digital converter, wherein the digital signal of the analogue/digital converter is communicating with a control element by means of a bus system.

[0006] The resistance element can be connected to means for supplying a stable voltage.

[0007] The resistance element is preferably a resistance potentiometer. This can have a defined minimum and maximum position.

[0008] Alternatively, the resistance element can be a resistance switch.

[0009] Furthermore, in an alternative solution, the adjustment device can comprise a rotating pulse encoder emitting at least two signals and means for evaluating the signals in order to determine the direction of rotation and the amount or angle of rotation.

[0010] In a preferred embodiment the adjustment knob and/or the shaft and/or the adjustment device and/or the resistance potentiometer and/or the resistance switch and/or the rotary pulse encoder have or has a defined minimum position and/or a defined maximum position, which can especially be defined by mechanical limiting or stopping means.

[0011] Preferably, a plurality of induction heating elements is arranged in the appliance. The appliance can have a panel-shaped stove or cooking top; this is bene-

ficially a ceramic or glass ceramic stove top.

[0012] The shaft usually penetrates the stove top. Then, the shaft is preferably sealed against the stove top by a seal device.

5 **[0013]** A plurality of adjustment knobs, shafts and adjustment devices can be arranged in a common frame.

[0014] The induction hob according to the invention using rotaries combines the advantages of an easy to use appliance with high performance and high safety for the user.

10 **[0015]** For the user which is not familiar with the touch controls or endless turn able knobs but is safety-conscious this combines several advantages:

15 The system is easy to use. It has a good mechanical feedback.

[0016] The electronic features can be implemented like an automatic boost function.

20 **[0017]** Safety functions can easily be established like low glass temperatures, pot detection or automatic power off.

[0018] The full advantages of the induction heating can be used like fast heat-up, high power and high efficiency.

25 **[0019]** Also, children lock functions can be employed.

[0020] An advantage of the system is the position depending control of power levels of the induction hob. In comparison to endless rotaries this input system gives mechanical feedback via the limitation on minimum and maximum positions. The power level can be adjusted via a display or the printing on knobs or the glass ceramic top.

30 **[0021]** In the drawings an embodiment of the invention is depicted.

35 FIG 1 shows a perspective exploded view of a domestic cooking appliance with four induction heating elements and

40 FIG 2 shows schematically the control unit for the cooking appliance with an adjustment knob and the electronic components of the device.

[0022] In the figures a domestic cooking appliance 1 is depicted. It has four induction heating elements 2, 3, 4, and 5. For adjusting the operational parameters of the heating elements, especially the power of the elements 2, 3, 4, 5, a control unit 6 is supplied.

[0023] The control unit 6 has a plurality of adjustments knobs 7; the number corresponds to the number of heating elements 2, 3, 4, 5. Each adjustment knob 7 has a shaft 8 which penetrated a stove top 14, which is made from glass ceramic.

[0024] The shaft 8 is connected to an adjustment device 9 (see especially FIG 2). The adjustment device 9 is connected to means 13 which supply a stable voltage.

55 **[0025]** As the adjustment device 9 is a potentiometer in the depicted embodiment a respective voltage is outputted from the adjustment device 9 to an analogue/dig-

ital converter 10 which transfers the outputted analogue voltage into a digital signal.

[0026] The potentiometer 9 has a minimum and a maximum turning position, i. e. the knob 7 can be turned between two extreme positions. Thus, the use of the system is convenient for user which have problems in using cooking appliances having touch control elements or endless turn able knobs only.

[0027] The transferred digital signal which is outputted from the analogue/digital converter 10 it fed to a control element 11 by means of a bus system 12. Bus systems as such are well known in the prior art. The control element 11 in turn is in electrical connection with the heating elements 2, 3, 4, 5.

[0028] The four adjustment knobs 7 with their adjustment devices 9 are mounted in a frame 16 which is mounted in turn in the hob below the ceramic stove top 14.

[0029] To make sure that liquids spilled on the stove top 14 do not influence the function of the electronic components, the bores in the stove top 14 for the shafts 8 are sealed in a suitable manner by a seal device 15.

[0030] The mentioned and depicted electrical and electronic elements are known in the prior art and are thus not explained in detail here. The man skilled in the art will have no problems in selecting suitable elements to implement the suggested concept.

[0031] Thus, the invention suggests an induction hob with rotaries. These rotaries are changing the mechanical position of the rotaries into an electrical signal.

[0032] This can be solved by a potentiometer or a resistance switch which is supported with a stable voltage.

[0033] The position of the rotary is calculated via an analogue/digital converter into a digital signal. This signal is used to communicate via a bus system to the induction electronics.

[0034] The hob can be supported with at least one rotary to control the at least one induction zone. The body of the rotary is preferably mounted in the inner side of the hob and is contacted via wires or via direct contact to the electronic that evaluates the position of the rotaries.

[0035] The axes of the rotaries are guided through the glass ceramic to the knobs on the top of the hob. The gaskets (seals) are protecting the hob against liquids. Sealing elements for hobs are also known as such; the man skilled in the art will find suitable solutions in the prior art.

[0036] In an embodiment not shown, the adjustment device 9 can comprise also a rotating pulse encoder instead of a resistance element or potentiometer. Such an encoder usually generates at least two pulsed signals and these signals are evaluated and serve to determine the direction of rotation and the amount or angle of rotation by incrementing or decrementing

Reference Numerals

[0037]

1	Cooking Appliance
2	Induction heating element
3	Induction heating element
4	Induction heating element
5	Induction heating element
6	Control unit
7	Adjustment knob
8	Shaft
9	Adjustment device
10	Analogue/digital converter
11	Control element
12	Bus system
13	Means for supplying a stable voltage
14	Stove top
15	Seal device
16	Frame

Claims

1. Cooking appliance (1), especially domestic cooking appliance, having at least one induction heating element (2, 3, 4, 5) and a control unit (6), wherein the control unit (6) has at least one adjustment knob (7) by which a shaft (8) can be rotated which is connected to an adjustment device (9) for a cooking parameter, which is part of the control unit (6), **characterized in that** the adjustment device (9) comprises a resistance element which is connected to an analogue/digital converter (10), wherein the digital signal of the analogue/digital converter (10) is communicating with a control element (11) by means of a bus system (12).
2. Cooking appliance according to claim 1, **characterized in that** the resistance element is connected to means (13) for supplying a stable voltage.
3. Cooking appliance according to claim 1 or 2, **characterized in that** the resistance element is a resistance potentiometer.
4. Cooking appliance according to claim 1 or 2, **characterized in that** the resistance element is a resistance switch.
5. Cooking appliance according to one of claims 1 to 4, **characterized in that** the adjustment knob (7) and/or the shaft (8) and/or the adjustment device (9) and/or the resistance potentiometer and/or the resistance switch has a defined minimum position and/or a defined maximum position, especially defined by mechanical limiting or stopping means.
6. Cooking appliance according to at least one of claims 1 to 5, **characterized in that** a plurality of induction heating elements (2, 3, 4, 5) is arranged in the appliance.

7. Cooking appliance according to at least one of claims 1 to 6, **characterized in that** the appliance has a panel-shaped cooking or stove top (14), in particular a ceramic or glass ceramic cooking top. 5
8. Cooking appliance according to claim 7, **characterized in that** the shaft (8) penetrates the cooking or stove top (14). 10
9. Cooking appliance according to claim 8, **characterized in that** the shaft (8) is sealed against the cooking top (14) by a seal device (15). 15
10. Cooking appliance according to at least one of claims 1 to 9, **characterized in that** a plurality of adjustment knobs (7), shafts (8) and adjustment devices (9) are arranged in a common frame (16). 20
11. Cooking appliance (1), especially domestic cooking appliance, in particular according to one of the preceding claims, having at least one induction heating element (2, 3, 4, 5) and a control unit (6), wherein the control unit (6) has at least one adjustment knob (7) by which a shaft (8) can be rotated which is connected to an adjustment device (9) for a cooking parameter, which is part of the control unit (6), **characterized in that** the adjustment device (9) comprises a rotating pulse encoder emitting at least two signals and means for evaluating the signals in order to determine the direction of rotation and the amount or angle of rotation. 25 30

35

40

45

50

55

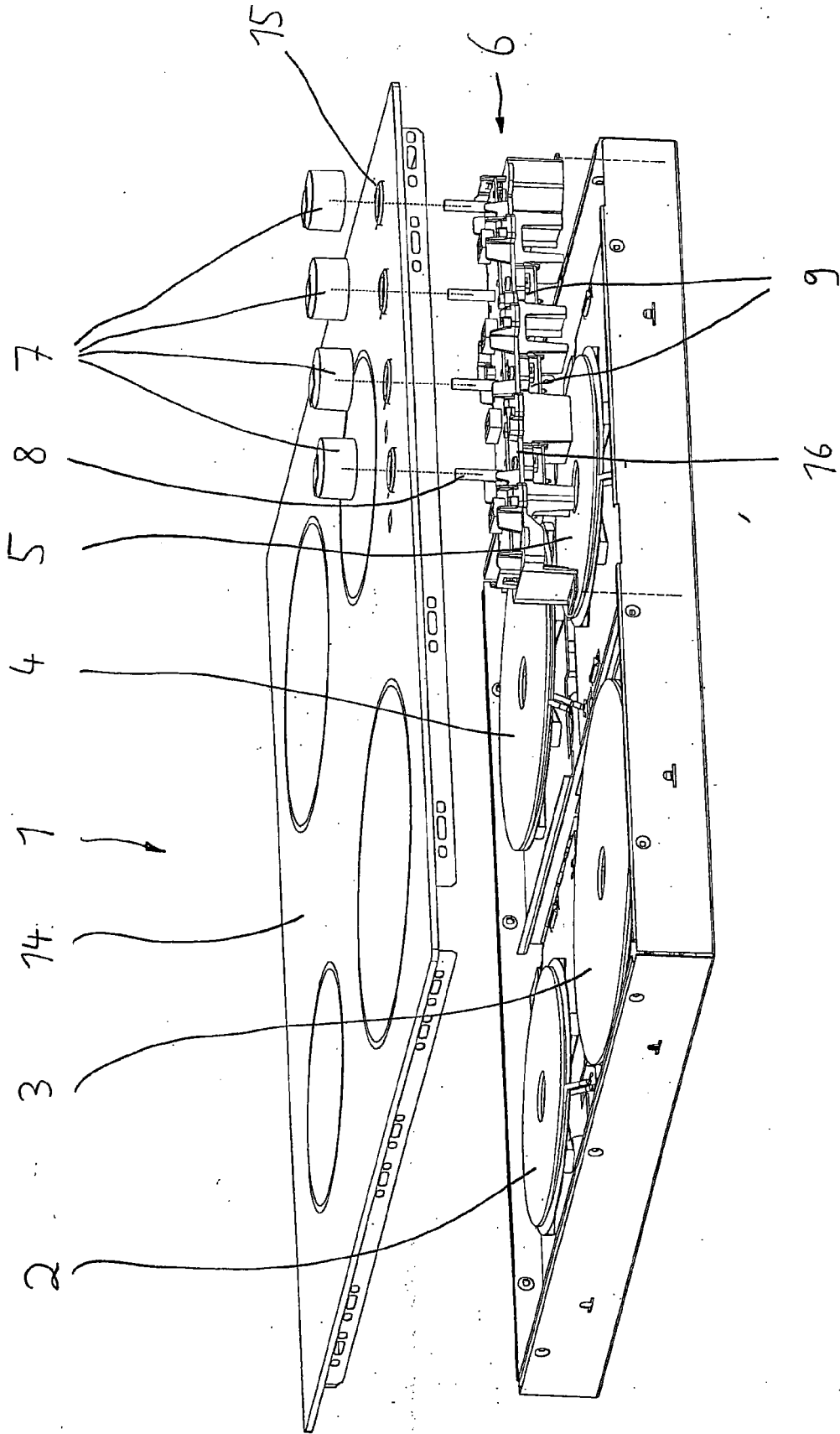

FIG 1

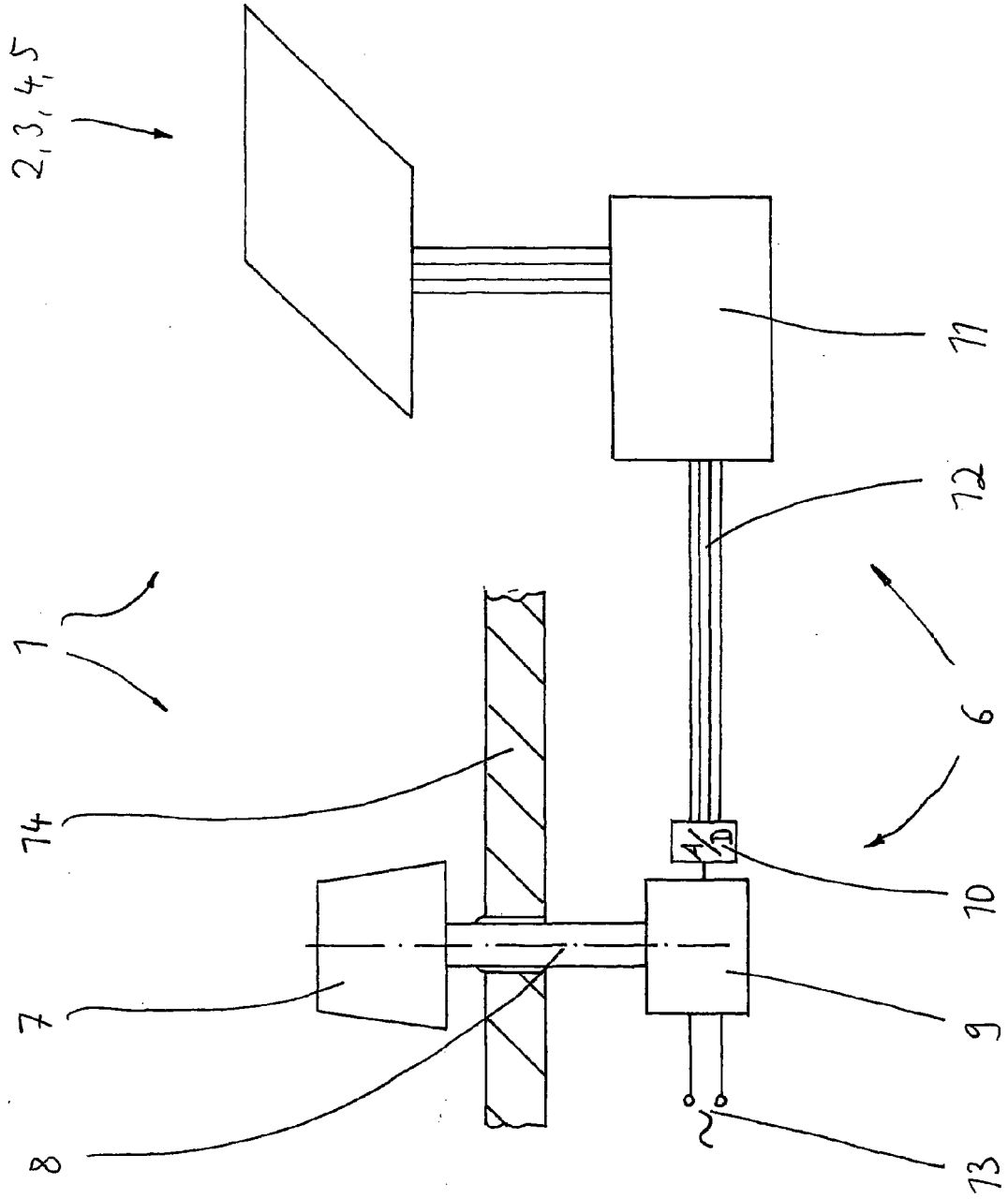

FIG 2



DOCUMENTS CONSIDERED TO BE RELEVANT			
Category	Citation of document with indication, where appropriate, of relevant passages	Relevant to claim	CLASSIFICATION OF THE APPLICATION (IPC)
X	US 2005/247693 A1 (FISHER GARY [US] ET AL FISHER GARY [US] ET AL) 10 November 2005 (2005-11-10)	1-3,6,7	INV. H05B6/06
Y	* paragraphs [0008], [0015], [0017], [0029]; figure 1 *	5,8,10	
X	US 2006/025874 A1 (HUFFINGTON JEFF [US] ET AL) 2 February 2006 (2006-02-02)	11	TECHNICAL FIELDS SEARCHED (IPC) H05B
Y	* paragraphs [0027] - [0032], [0036], [0052], [0053]; figures 1-4 *	5	
X	US 2003/094448 A1 (SHUKLA SANJAY [US] ET AL) 22 May 2003 (2003-05-22)	1-3,7	
Y	* paragraphs [0005], [0006], [0008], [0021] - [0028], [0042] *		
Y	EP 0 318 645 A (TOKYO SHIBAURA ELECTRIC CO [JP]) 7 June 1989 (1989-06-07)	1,2,6,7	
Y	* column 1, paragraph 1; figures 1,2 * * column 5, line 26 - line 34 *		
Y	DE 198 34 641 A1 (CHERRY GMBH [DE]) 17 February 2000 (2000-02-17)	1,2,6,7	
Y	* column 1, line 15 - line 20 * * column 4, line 17 - line 26; figures *		
Y	US 2005/269311 A1 (ARNTZ TIMOTHY J [US] ET AL) 8 December 2005 (2005-12-08)	8,10	
A	* paragraphs [0015], [0016]; figure 1 *		
A	EP 1 675 435 A (BRANDT IND [FR]) 28 June 2006 (2006-06-28)	1,6	
A	* paragraphs [0025], [0032]; figure 1 *		
A	DE 43 38 082 A1 (BOSCH SIEMENS HAUSGERAETE [DE]) 11 May 1995 (1995-05-11)	1	
	* abstract; figures *		
The present search report has been drawn up for all claims			
Place of search The Hague		Date of completion of the search 11 February 2008	Examiner Verdoedt, Luk
CATEGORY OF CITED DOCUMENTS		T : theory or principle underlying the invention E : earlier patent document, but published on, or after the filing date D : document cited in the application L : document cited for other reasons & : member of the same patent family, corresponding document	
X : particularly relevant if taken alone Y : particularly relevant if combined with another document of the same category A : technological background O : non-written disclosure P : intermediate document			

**ANNEX TO THE EUROPEAN SEARCH REPORT
ON EUROPEAN PATENT APPLICATION NO.**

EP 07 01 6159

This annex lists the patent family members relating to the patent documents cited in the above-mentioned European search report. The members are as contained in the European Patent Office EDP file on
The European Patent Office is in no way liable for these particulars which are merely given for the purpose of information.

11-02-2008

Patent document cited in search report	Publication date	Patent family member(s)	Publication date
US 2005247693 A1	10-11-2005	NONE	
US 2006025874 A1	02-02-2006	NONE	
US 2003094448 A1	22-05-2003	NONE	
EP 0318645 A	07-06-1989	CA 1304137 C DE 3873700 D1 DE 3873700 T2 US 4900884 A	23-06-1992 17-09-1992 21-01-1993 13-02-1990
DE 19834641 A1	17-02-2000	WO 0008531 A1 EP 1103021 A1 ES 2229758 T3	17-02-2000 30-05-2001 16-04-2005
US 2005269311 A1	08-12-2005	CA 2506249 A1	04-12-2005
EP 1675435 A	28-06-2006	FR 2879724 A1	23-06-2006
DE 4338082 A1	11-05-1995	EP 0655584 A1	31-05-1995

REFERENCES CITED IN THE DESCRIPTION

This list of references cited by the applicant is for the reader's convenience only. It does not form part of the European patent document. Even though great care has been taken in compiling the references, errors or omissions cannot be excluded and the EPO disclaims all liability in this regard.

Patent documents cited in the description

- DE 29701430 U1 [0002]