



(11) **EP 2 029 457 B9**

(12) **CORRECTED EUROPEAN PATENT SPECIFICATION**

(15) Correction information:  
**Corrected version no 1 (W1 B1)**  
**Corrections, see**  
**Description Paragraph(s) 7**

(51) Int Cl.:  
**B65D 85/804 (2006.01)**

(86) International application number:  
**PCT/EP2007/054986**

(48) Corrigendum issued on:  
**15.09.2010 Bulletin 2010/37**

(87) International publication number:  
**WO 2007/137974 (06.12.2007 Gazette 2007/49)**

(45) Date of publication and mention  
of the grant of the patent:  
**24.03.2010 Bulletin 2010/12**

(21) Application number: **07729424.7**

(22) Date of filing: **23.05.2007**

(54) **COFFEE CAPSULE WITH A DEFORMABLE SEALING ELEMENT**

KAFFEEKAPSEL MIT EINEM VERFORMBAREN VERSIEGELUNGSELEMENT

CAPSULE DE CAFÉ POURVUE D'UN ÉLÉMENT DE FERMETURE HERMÉTIQUE DÉFORMABLE

(84) Designated Contracting States:  
**AT BE BG CH CY CZ DE DK EE ES FI FR GB GR**  
**HU IE IS IT LI LT LU LV MC MT NL PL PT RO SE**  
**SI SK TR**  
Designated Extension States:  
**AL BA HR MK RS**

(73) Proprietor: **Nestec S.A.**  
**1800 Vevey (CH)**

(72) Inventor: **SIMANSKI, Bernd**  
**58636 Iserlohn (DE)**

(30) Priority: **29.05.2006 CH 8642006**

(74) Representative: **Borne, Patrice Daniel**  
**Nestec S.A.**  
**Avenue Nestlé 55**  
**1800 Vevey (CH)**

(43) Date of publication of application:  
**04.03.2009 Bulletin 2009/10**

(56) References cited:  
**EP-A1- 1 654 966 FR-A1- 2 617 389**

**EP 2 029 457 B9**

Note: Within nine months of the publication of the mention of the grant of the European patent in the European Patent Bulletin, any person may give notice to the European Patent Office of opposition to that patent, in accordance with the Implementing Regulations. Notice of opposition shall not be deemed to have been filed until the opposition fee has been paid. (Art. 99(1) European Patent Convention).

## Description

### Technical field of the invention

**[0001]** The present invention relates to a portion packaging with a deformable sealing element.

### Prior art

**[0002]** The prior art discloses a multiplicity of such portion packagings and devices for the extraction of a drink. For example, EP 0 512 470 discloses a portion packaging for producing a drink with a corresponding device.

**[0003]** However, many portion packagings and their associated devices have the disadvantage that the tightness between portion packaging and device cannot always be ensured.

This has a disadvantageous effect on the quality of the drink to be prepared.

**[0004]** FR 2616389 relates to a filter cartridge for preparing a beverage comprising a filtering bottom and a cup-shaped plastic body with a thick rim which becomes incrustated by a seat of the beverage device.

**[0005]** EP1654966A1, upon which the two-part from of claim 1 is based, relates to a capsule with a plain or hollow sealing member which is deformable under the pressure of an enclosing member of the beverage producing device.

### Summary of the invention

**[0006]** It is an object of the invention to design a portion packaging and a device for producing a drink in such a manner that high fluid tightness between portion packaging and device can be produced, and that the portion packaging can be used with devices of the prior art.

**[0007]** It is a further object of the invention that only the portion packaging designed according to the invention and not portion packagings of the prior art can be used in the device according to the invention.

A portion packaging with the features of Patent Claim 1 achieves this object. Advantageous refinements of the invention are indicated in the dependent claims.

A portion packaging for receiving a substance generally comprises a curved base and a transition region integrally formed on this base, a side wall which is integrally formed on this transition region and extends conically, and an edge which is integrally formed on this side wall and protrudes outwards and which can also be referred to as a flange. The base, the transition region and the side wall form a cavity for receiving a substance, in particular coffee. The cavity has an opening which is closable with a film and is used for pouring in the substance, such as, for example, coffee powder. According to the invention, a deformable sealing element is integrally formed on the portion packaging.

**[0008]** The deformable sealing element can be deformed by means of a holding-down device and/or a

counterpart of a corresponding extraction device before and/or during an extraction operation. The deformation is such that a fluid-tight contact can be produced between the holding-down device, the counterpart and the sealing element.

**[0009]** The fluid-tight contact permits a drink to be extracted from a substance under high pressure. This is particularly advantageous if, for example, a coffee drink is to be extracted from ground coffee.

**[0010]** The deformation or squeezing of the sealing element has the advantage over a different type of deformation, such as, for example, a resilient deformation of a sealing element, that greater tightness is achieved between capsule and holding-down device.

**[0011]** When the holding-down device is closed, there is a spacing between a lower edge of the holding-down device and the protruding edge of the portion packaging. The spacing preferably has a height of 0.05 mm to 0.5 mm.

The height extends from the surface of the protruding edge as far as the lower edge of the holding-down device.

**[0012]** A spacing of this type has the advantage that the pressure arising during the extraction can spread as far as the sealing point.

**[0013]** The sealing element is preferably arranged essentially on the outer border of the protruding edge and is in the form of a rollover edge.

**[0014]** An arrangement and configuration of this type makes it possible for a portion packaging according to the present invention to be produced in a particularly simple and therefore cost-effective manner.

**[0015]** The rollover edge essentially has an elliptical or oval cross-sectional shape. The rollover edge is integrally formed with a first region on the outer border of the protruding edge. The first region has a rounded shape and protrudes downwards, i.e. in the direction of the counterpart. A second region is integrally formed on the first region in such a manner that the second region is arranged essentially at right angles to the surface of the protruding edge. A third region is integrally formed on the second region, the third region having a rounded shape. A fourth region is integrally formed on the third region and extends essentially parallel to the second region. The fourth region can in this case be connected to the outer border of the protruding edge or can be free-standing or can be rolled inwards, the free end then being surrounded by the four regions.

**[0016]** Alternatively, the first region can also protrude upwards, i.e. away from the counterpart. The configuration of the second region, the third region and the fourth region are designed in the same manner as described above.

**[0017]** The rollover edge with the elliptical or round cross section extends preferably up to 1/3 downwards from the protruding side edge, i.e. in the direction of the counterpart, and up to 2/3 upwards, i.e. away from the counterpart. Other ratios are, of course, also possible, in particular it is conceivable for the ratio to be 1:1. However,

the ratio may also be 1/5 to 4/5.

**[0018]** The rollover edge preferably has a height of 0.5 mm to 2.5 mm. A height of 1.0 mm to 1.8 mm is particularly preferred. The width of the rollover edge preferably lies in the range of from 0.3 mm to 0.8 mm. A width of 0.5 mm to 0.7 mm is particularly preferred.

**[0019]** The distance from the side wall as far as the rollover edge, which distance essentially corresponds to the width of the protruding edge or flange, is preferably between 1 mm and 5 mm. A distance of 1.5 mm and 3 mm is particularly preferred.

**[0020]** In particular, the second region, the third region and the fourth region can be deformed by a corresponding sealing region of the holding-down device.

**[0021]** This elliptical or oval cross-sectional shape can be deformed particularly readily and a good sealing action can be obtained, which has a positive effect on the extraction operation.

**[0022]** The height of the rollover edge is preferably greater than the width of the rollover edge, with the height extending in the direction of actuation of the holding-down device.

**[0023]** During the deformation operation, the fourth region can be conducted into the inside of the rounded shape of the first region. This brings about a particularly good sealing action. In the process, the rollover edge is deformed, i.e. irreversibly deformed or squeezed. In this case, a complete return of the rollover edge into its original form after the holding-down device is removed is impossible. However, it is also possible for the deformation of the rollover edge or of the sealing element to be only partially plastic. In this case, the deformation accordingly has a plastic and also an elastic component. Parts of the rollover edge can therefore return into their original form after the holding-down device is removed.

**[0024]** Furthermore, it is possible for the rollover edge which is integrally formed on the outer border of the protruding region to only have one region. This region essentially assumes a round cross-sectional shape. A spiral cross-sectional shape is also conceivable.

**[0025]** In addition, the sealing element can be arranged on the side wall and can be essentially configured as a bead.

**[0026]** Furthermore, the sealing element can be arranged on the protruding side edge and can be essentially configured as a bead.

**[0027]** The portion packaging is preferably produced from aluminium or an aluminium alloy. In addition, the portion packaging can be provided on its inside and/or outside with a layer composed of plastic or of other materials.

**[0028]** In general, the sealing element can be made of aluminium and/or plastic and/or rubber-elastic material. In that case, the portion packaging can partially or entirely be made of plastic material. For instance, the sealing element can be made of an aluminium support and a rubber-elastic external lining that improves fluid tightness.

**[0029]** The portion packaging preferably has an average wall thickness of 0.05 mm to 0.12 mm. An average wall thickness of 0.07 mm to 0.10 mm is particularly preferred.

5 **[0030]** The portion packaging is preferably produced by means of a deep-drawing process, in particular, when the portion packaging comprises aluminium or aluminium alloy. This permits efficient and cost-effective production of the portion packaging.

10 **[0031]** When in plastic, the portion packaging can also be produced by thermoforming or injection moulding.

**[0032]** A device for producing a drink by extraction of the same from a substance contained in a portion packaging, the portion packaging being insertable into the device, comprises at least one holding-down device and a counterpart with a punching plate. The holding-down device and/or the counterpart are equipped with means for the sealing deformation of parts of the portion packaging. A depression which is complementary to, the sealing element is arranged in a lower region of the holding-down device and/or a depression which is complementary to the sealing element is arranged in the counterpart. However, the depressions can also be arranged just on one of the two elements, i.e. either on the holding-down device or on the counterpart. The sealing therefore takes place without additional elements, such as, for example, a rubber ring, etc.

#### Brief description of the figures

30

**[0033]** The invention is described in more detail below with reference to the drawing, in which:

35

Fig. 1 shows an exemplary embodiment of a portion packaging and elements of a device according to the present invention before the extraction operation;

40

Fig. 2 shows the exemplary embodiment of Figure 1 shortly before the extraction operation; and

45

Fig. 3 shows the exemplary embodiment of Figure 1 during the extraction operation.

#### Description of an exemplary embodiment

50

**[0034]** An example of a portion packaging according to the present invention and elements of an example of a device according to the present invention are shown in Figure 1. The portion packaging is shown here as a coffee capsule 1.

55

**[0035]** The coffee capsule 1 serves to receive ground coffee for the preparation of a coffee drink. A transition region 12 is integrally formed on a curved base 11. A side wall 13 is integrally formed on the transition region 12. An outwardly protruding edge 14 is integrally formed on the side wall 13. The outwardly protruding edge 4 is configured in the shape of a circular disc ring and has a

planar surface. The outwardly protruding edge 14 may also be referred to as a flange. The base 11, the transition region 12 and the side wall 13 form a cavity 15 with an opening. The cavity 15 serves to receive the substance, here coffee powder, which can be poured through the opening. The opening is closable with a film. Furthermore, a deformable sealing element 3 is arranged on the portion packaging, in the preferred exemplary embodiment the sealing element 3 is arranged on the outside of the protruding edge 14. The portion packaging is configured in a rotationally symmetrical manner with respect to a central axis A-A.

**[0036]** In the present exemplary embodiment, the curvature of the curved base extends into the cavity 15.

**[0037]** In the present exemplary embodiment, the sealing element 3 is configured as a rollover edge which essentially has an elliptical or oval cross-sectional shape. The rollover edge is integrally formed with a first region 31 on the outer border of the protruding edge 14. The first region 31 in cross section has a rounded shape which is essentially semicircular. The first region extends downwards from the protruding edge 14.

**[0038]** A second region 32 which extends essentially at right angles to the surface of the protruding edge 14 is integrally formed on the first region 31. In addition, the second region 32 extends over the protruding edge 14. Accordingly, part of the rollover edge extends below the protruding edge 14 while another part of the rollover edge extends above the protruding edge 14.

**[0039]** A third region 33 is integrally formed on the second region 32. The third region 33 in cross section has a rounded cross-sectional shape which is essentially semicircular.

**[0040]** A fourth region 34 is integrally formed on the third region 33. The fourth region 34 is essentially parallel to the second region 32. In the present exemplary embodiment, the end of the fourth region is free-standing, i.e. it is not connected to the protruding side edge 14.

**[0041]** In the preferred exemplary embodiment, the height of the rollover edge has a greater size than the width of the rollover edge.

**[0042]** A cavity 35 which is bounded by the four regions 31, 32, 33, 34 is formed by the described configuration of the rollover edge.

**[0043]** The device of the present invention serves to produce a drink, such as, for example, coffee. In this case, the above-described coffee capsule 1 can be inserted into the device. The device comprises at least one holding-down device 2 and a counterpart 4 with a punching plate 5 onto which the coffee capsule 1 is placed.

**[0044]** The holding-down device 2 is movable axially with respect to the counterpart 4 and the coffee capsule 1 placed onto it.

**[0045]** In the present exemplary embodiment, the holding-down device 2 has a hollow-cylindrical shape with an annular base surface with an outside 23 and an inside 24. A lower edge 22 forms a lower end of the holding-down device 2. A sealing region 21 is arranged on

the lower edge 22 in the vicinity of the outside 23 and extends into the holding-down device 2. The sealing region 21 has in this case a shape which is essentially complementary to the rollover edge seal of the coffee capsule 1, and a sealing action is obtained on account of the deformation of the rollover edge and by means of the shaping of the sealing region. The sealing region 21 extends over the entire circumference of the hollow-cylindrical holding-down device 2.

**[0046]** The counterpart 4 has a supporting surface 42 and a depression 41. The depression 41 has a shape which is complementary to the rollover edge seal of the coffee capsule 1. The depression 41 of the counterpart 4 and the sealing region 21 of the holding-down device 2 are aligned concentrically with respect to each other.

**[0047]** The coffee capsule 1 is then placed onto the supporting surface 42 in such a manner that the rollover edge comes to lie in the depression 41 and that the opening which is closed with the film rests on the supporting surface 42 and on the punching plate 5. The coffee capsule 1 is now likewise concentric with respect to the depression 41 and to the sealing region 21. That is to say, the central axis of the coffee capsule, the central axis of the holding-down device and the central axis of the counterpart are concentric with respect to one another.

**[0048]** After a capsule is inserted, the holding-down device is moved along the central axis A-A towards the supporting surface 42. In the process, the sealing region 21 of the holding-down device strikes against the rollover edge of the capsule. This can readily be seen in Figure 2.

**[0049]** The punching plate 5 serves, inter alia, together with the holding-down device to deform the film which closes the cavity 15. Furthermore, there are mechanical elements which pierce the coffee capsule in the region of the base, so that the extraction fluid can penetrate the capsule. These operations are known to a person skilled in the art, and so a description thereof is superfluous.

**[0050]** Figure 3 shows the holding-down device 2 in its end position. If the holding-down device 2 is in this position, the drink can be extracted, here from the coffee powder. It can clearly be seen in this figure that the free-standing, fourth region 34 of the rollover edge has moved along the internal contour of the first region 31. This deformation of the rollover edge achieves fluid-tight contact between the holding-down device 2 and the counterpart 4. This produces a space 8 which is closed in a fluid-tight manner with respect to the environment.

**[0051]** It can be likewise be seen in Figure 3 that there is a spacing 7 between the protruding edge 14 of the coffee capsule 1 and the lower edge 22 of the holding-down device. There is no contact between the lower edge 22 of the holding-down device 2 and the protruding edge 14 of the coffee capsule 1. The spacing 7 preferably has a height of 0.05 mm to 0.5 mm. A height of 0.1 mm to 0.3 mm is particularly preferred. The height extends from the surface of the protruding edge 14 as far as the lower edge of the holding-down device 2.

**[0052]** By pressurization of the space during the ex-

traction of the drink, the increased pressure in the space 8 can spread through the spacing 7 as far as the rollover edge seal. In the process, the pressure can enter the interior space 35 of the rollover edge seal, with the individual regions then being deformed outwards. This deformation is limited by the holding-down device 2, the counterpart 4 and a mechanical outer element (not shown) which touches the second region 32 of the rollover edge. This deformation achieves particularly effective sealing.

**[0053]** The holding-down device 2 can be made movable using mechanical means and/or hydraulic means. In a preferred example, the holding-down device is first moved by way of a mechanical actuator, i.e., a cam, knee joint or other lever mechanism, followed by a final hydraulic closure. The final hydraulic closure is obtained by the holding-down device 2 comprising a movable piston forming at least the sealing region 21 and lower edge 22 of the device and mounted on a fixed support of the device.

#### List of reference numbers

#### [0054]

1	Coffee capsule
2	Holding-down device
3	Sealing element, rollover edge of capsule, deforming seal
4	Counterpart
5	Punching plate
7	Spacing
8	Space
11	Base
12	Transition region
13	Side wall
14	Protruding edge
15	Cavity
21	Sealing region
22	Lower edge
31	First region
32	Second region
33	Third region
34	Fourth region

#### Claims

1. Portion packaging for receiving a substance to produce a drink comprising a cavity for receiving a substance, a side wall (13) and an edge (14) which is integrally formed on this side wall (13) and protrudes outwards, wherein the cavity (15) has an opening, which is closed by a film (5) wherein a deformable sealing element (3) is arranged on the portion pack-

aging **characterized in that** the sealing element (3) is configured as a rollover edge which essentially has an elliptical or oval cross-sectional shape, and the height of the rollover edge is greater than the width thereof.

2. Portion packaging according to Claim 1, **characterized in that** the deformable sealing element (3) can be deformed by means of a holding-down device (2) and/or a counterpart (5) of a corresponding extraction device before and/or during an extraction operation in such a manner that a fluid-tight contact can be produced between the holding-down device (2), the counterpart (5) and the sealing element (3).

3. Portion packaging according to Claim 1, **characterized in that**, when the holding-down device (2) is closed, there is a spacing (7) between a lower edge (22) of the holding-down device (2) and the protruding edge (14) of the portion packaging.

4. Portion packaging according to Claim 3, **characterized in that** the spacing (7) has a height of preferably 0.05 mm to 0.5 mm, with the height extending from the surface of the protruding edge (14) as far as the lower edge of the holding-down device (2).

5. Portion packaging according to Claim 1, **characterized in that**, the rollover edge is integrally formed with a first region (31) on the outer border of the protruding edge (14), the first region (31) having a rounded shape and protruding downwards, and **in that** a second region (32) is integrally formed on the first region (31) such that the second region (32) is arranged essentially at right angles to the surface of the protruding edge (14), and **in that** a third region (33) is integrally formed on the second region (32), the third region (33) having a rounded shape, and **in that** a fourth region (34) is integrally formed on the third region (33), the fourth region (34) extending essentially parallel to the second region (32), and **in that** fourth region (32) is connected to the outer border of the protruding edge or is free-standing.

6. Portion packaging according to Claim 1, **characterized in that** the rollover edge is integrally formed with a first region (31) on the outer border of the protruding edge (14), the first region (31) having a rounded shape and protruding upwards, and **in that** a second region (32) is integrally formed on the first region (31) such that the second region (32) is arranged essentially at right angles to the surface of the protruding edge (14), and **in that** a third region (33) is integrally formed on the second region (32), the third region (33) having a rounded shape, and **in that** a fourth region (34) is integrally formed on the third region (33), the fourth region (34) extending essentially parallel to the second region (32), and **in**

- that fourth region (32) is connected to the outer border of the protruding edge or is free-standing.
7. Portion packaging according to Claim 5 or 6, **characterized in that** the second region (32), the third region (33) and the fourth region (34) can be deformed by a corresponding sealing region (21) of the holding-down device (2).
  8. Portion packaging according to one of Claims 5 to 7, **characterized in that**, during the deformation operation, the fourth region (34) is conducted into the inside of the rounded shape of the first region (31).
  9. Portion packaging according to Claim 1, **characterized in that** the rollover edge is integrally formed on the outer border of the protruding edge (14), and **in that** the rollover edge has one region (41), the one region (41) assuming an essentially round cross-sectional shape.
  10. Portion packaging according to Claim 9, **characterized in that** the rollover edge extends upwards and/or downwards from the protruding edge.
  11. Portion packaging according to one of the preceding claims, **characterized in that** the portion packaging is made from aluminium or an aluminium alloy.
  12. Portion packaging according to Claim 11, **characterized in that** the portion packaging is provided on its inside and/or outside with a layer composed of plastic.
  13. Portion packaging according to one of the preceding claims, **characterized in that** the portion capsule has an average wall thickness of 0.05 mm to 0.12 mm.
  14. Method for producing a portion packaging according to any of the preceding claims, **characterized in that** the portion capsule is produced by means of a deep-drawing process.
  15. Device for producing a drink by extraction of the same from a substance contained in a portion packaging according to any of the claims 1-13 the portion packaging being insertable into the device, comprising at least one holding-down device (2) and a counterpart (4) with a punching plate (5), the holding-down device (2) and/or the counterpart (4) being equipped with means for deforming the sealing element of the portion packaging, **characterized in that** a depression (21) which is complementary to the sealing element is arranged in a lower region of the holding-down device (2), and/or **in that** a depression (41) which is complementary to the sealing element is arranged in the counterpart, the depression (s) producing the sealing deformation of the portion packaging.
16. Use of the portion packaging according to Claim 1 in a device according to Claim 15 for the extraction of a drink.

#### Patentansprüche

1. Portionspackung zum Aufnehmen eines Stoffes zum Herstellen eines Getränks, die einen Hohlraum zum Aufnehmen eines Stoffes, eine Seitenwand (13) und einen Rand (14) aufweist, der integral auf dieser Seitenwand (13) ausgebildet ist und nach außen vorsteht, wobei der Hohlraum (15) eine Öffnung hat, die durch eine Folie (5) verschlossen ist, wobei ein verformbares Versiegelungselement (3) auf der Portionspackung angeordnet ist, **dadurch gekennzeichnet, dass** das Versiegelungselement (3) als ein umgebündelter Rand ausgebildet ist, der im Wesentlichen eine elliptische oder ovale Querschnittsform hat, und die Höhe des umgebündelten Rands größer als seine Breite ist.
2. Portionspackung gemäß Anspruch 1, **dadurch gekennzeichnet, dass** das verformbare Versiegelungselement (3) mit Hilfe einer Niederhaltevorrichtung (2) und/oder eines Gegenstücks (5), das einer Extraktionsvorrichtung entspricht, vor und/oder während eines Extraktionsbetriebs in einer derartigen Weise verformt werden kann, dass ein fluidichter Kontakt zwischen der Niederhaltevorrichtung (2), dem Gegenstück (5) und dem Versiegelungselement (3) hergestellt werden kann.
3. Portionspackung gemäß Anspruch 1, **dadurch gekennzeichnet, dass** es einen Zwischenraum (7) zwischen einem unteren Rand (22) der Niederhaltevorrichtung (2) und dem vorstehenden Rand (14) der Portionspackung gibt, wenn die Niederhaltevorrichtung (2) geschlossen ist.
4. Portionspackung gemäß Anspruch 3, **dadurch gekennzeichnet, dass** der Zwischenraum (7) eine Höhe von vorzugsweise 0,05 mm bis 0,5 mm hat, wobei die Höhe sich von der Oberfläche des vorstehenden Rands (14) so weit wie der untere Rand der Niederhaltevorrichtung (2) erstreckt.
5. Portionspackung gemäß Anspruch 1, **dadurch gekennzeichnet, dass** der umgebündelte Rand integral mit einem ersten Bereich (31) auf der Außengrenze des vorstehenden Rands (14) ausgebildet ist, wobei der erste Bereich (31) eine abgerundete Form hat und nach unten vorsteht, und **dadurch, dass** ein zweiter Bereich (32) integral auf dem ersten Bereich (31) ausgebildet ist, so dass der zweite Be-

- reich (32) im Wesentlichen in rechten Winkeln zu der Oberfläche des vorstehenden Rands (14) angeordnet ist, und **dadurch**, dass ein dritter Bereich (33) integral auf dem zweiten Bereich (32) ausgebildet ist, wobei der dritte Bereich (33) eine abgerundete Form hat, und **dadurch**, dass ein vierter Bereich (34) integral auf dem dritten Bereich (33) ausgebildet ist, wobei der vierte Bereich (34) sich im Wesentlichen parallel zu dem zweiten Bereich (32) erstreckt, und **dadurch**, dass der vierte Bereich (32) mit der Außengrenze des vorstehenden Rands verbunden ist oder freistehend ist.
6. Portionspackung gemäß Anspruch 1, **dadurch gekennzeichnet, dass** der umgebündelte Rand integral mit einem ersten Bereich (31) auf der Außengrenze des vorstehenden Rands (14) ausgebildet ist, wobei der erste Bereich (31) eine abgerundete Form hat und nach oben vorsteht, und **dadurch**, dass ein zweiter Bereich (32) integral auf dem ersten Bereich (31) ausgebildet ist, so dass der zweite Bereich (32) im Wesentlichen in rechten Winkeln zu der Oberfläche des vorstehenden Rands (14) angeordnet ist, und **dadurch**, dass ein dritter Bereich (33) integral auf dem zweiten Bereich (32) ausgebildet ist, wobei der dritte Bereich (33) eine abgerundete Form hat, und **dadurch**, dass ein vierter Bereich (34) integral auf dem dritten Bereich (33) ausgebildet ist, wobei der vierte Bereich (34) sich im Wesentlichen parallel zu dem zweiten Bereich (32) erstreckt, und **dadurch**, dass der vierte Bereich (32) mit der Außengrenze des vorstehenden Rands verbunden ist oder freistehend ist.
7. Portionspackung gemäß Anspruch 5 oder 6, **dadurch gekennzeichnet, dass** der zweite Bereich (32), der dritte Bereich (33) und der vierte Bereich (34) durch einen entsprechenden Versiegelungsbereich (21) der Niederhaltevorrichtung (2) verformt werden können.
8. Portionspackung gemäß einem Ansprüche 5 bis 7, **dadurch gekennzeichnet, dass** der vierte Bereich (34) während des Verformungsvorgangs in das Innere der abgerundeten Form des ersten Bereichs (31) geführt wird.
9. Portionspackung gemäß Anspruch 1, **dadurch gekennzeichnet, dass** der umgebündelte Rand integral auf der Außengrenze des vorstehenden Rands (14) ausgebildet ist, und **dadurch**, dass der Überschlagrand einen Bereich (41) hat, wobei der eine Bereich (41) eine im Wesentlichen runde Querschnittform annimmt.
10. Portionspackung gemäß Anspruch 9, **dadurch gekennzeichnet, dass** der umgebündelte Rand sich von dem vorstehenden Rand nach oben und/oder nach unten erstreckt.
11. Portionspackung gemäß einem der vorhergehenden Ansprüche, **dadurch gekennzeichnet, dass** die Portionspackung aus Aluminium oder einer Aluminiumlegierung hergestellt ist.
12. Portionspackung gemäß Anspruch 11, **dadurch gekennzeichnet, dass** die Portionspackung auf ihrer Innenseite und/oder Außenseite mit einer aus Kunststoff bestehenden Schicht versehen ist.
13. Portionspackung gemäß einem der vorhergehenden Ansprüche, **dadurch gekennzeichnet, dass** die Portionskapsel eine durchschnittliche Wanddicke von 0,05 mm bis 0,12 mm hat.
14. Verfahren zur Herstellung einer Portionspackung gemäß einem der vorhergehenden Ansprüche, **dadurch gekennzeichnet, dass** die Portionskapsel mit Hilfe eines Tiefziehverfahrens hergestellt wird.
15. Vorrichtung zur Herstellung eines Getränks durch Aufguss desselben aus einem Stoff, der in einer Portionspackung gemäß einem der Ansprüche 1-13 enthalten ist, wobei die Portionspackung in die Vorrichtung einsetzbar ist, welche wenigstens eine Niederhaltevorrichtung (2) und ein Gegenstück (4) mit einer Stanzplatte (5) aufweist, wobei die Niederhaltevorrichtung (2) und/oder das Gegenstück (4) mit Einrichtungen zum Verformen des Versiegelungselements der Portionspackung ausgestattet sind, **dadurch gekennzeichnet, dass** eine Vertiefung (21), die komplementär zu dem Versiegelungselement ist, in einem unteren Bereich der Niederhaltevorrichtung (2) angeordnet ist, und/oder **dadurch**, dass eine Vertiefung (41), die komplementär zu dem Versiegelungselement ist, in dem Gegenstück angeordnet ist, wobei die Vertiefung(en) die Versiegelungsverformung der Portionspackung erzeugen.
16. Verwendung der Portionspackung gemäß Anspruch 1 in einer Vorrichtung gemäß Anspruch 15 für die Extraktion eines Getränks.

#### Revendications

1. Emballage de portion pour recevoir une substance pour produire une boisson comprenant une cavité pour recevoir une substance, une paroi latérale (13) et un rebord (14) qui est intégralement formé sur cette paroi latérale (13) et fait saillie vers l'extérieur, la cavité (15) ayant une ouverture qui est fermée par un film (5), un élément d'étanchéité déformable (3) étant disposé sur l'emballage de portion, **caractérisé en ce que** l'élément d'étanchéité (3) est configuré comme un rebord de prolongement qui a

- essentiellement une forme elliptique ou ovale en coupe transversale, et la hauteur du rebord de prolongement est plus grande que sa largeur.
2. Emballage de portion selon la revendication 1, **caractérisé en ce que** l'élément d'étanchéité déformable (3) peut être déformé par un dispositif de maintien vers le bas (2) et/ou un pendant (5) d'un dispositif d'extraction correspondant avant et/ou pendant une opération d'extraction de telle façon qu'un contact imperméable à un fluide peut être produit entre le dispositif de maintien vers le bas (2), le pendant (5) et l'élément d'étanchéité (3). 5
  3. Emballage de portion selon la revendication 1, **caractérisé en ce que**, lorsque le dispositif de maintien vers le bas (2) est fermé, il y a un espace (7) entre un rebord inférieur (22) du dispositif de maintien vers le bas (2) et le rebord faisant saillie (14) de l'emballage de portion. 10
  4. Emballage de portion selon la revendication 3, **caractérisé en ce que** l'espace (7) a une hauteur de 0,05 mm à 0,5 mm de préférence, avec la hauteur s'étendant de la surface du rebord faisant saillie (14) jusqu'au rebord inférieur du dispositif de maintien vers le bas (2). 15
  5. Emballage de portion selon la revendication 1, **caractérisé en ce que** le rebord de prolongement est intégralement formé avec une première région (31) sur le bord extérieur du rebord faisant saillie (14), la première région (31) ayant une forme arrondie et s'étendant vers le bas, et **en ce que** une deuxième région (32) est intégralement formée sur la première région (31) de sorte que la deuxième région (32) est disposée essentiellement à angles droits par rapport à la surface du rebord faisant saillie (14), et **en ce que** une troisième région (33) est intégralement formée sur la deuxième région (32), la troisième région (33) ayant une forme arrondie, et **en ce que** une quatrième région (34) est intégralement formée sur la troisième région (33), la quatrième région (34) s'étendant essentiellement parallèlement à la deuxième région (32), et **en ce que** la quatrième région (32) est connectée au bord extérieur du rebord faisant saillie ou est libre. 20
  6. En emballage de protection selon la revendication 1, **caractérisé en ce que** le rebord de prolongement est intégralement formé avec une première région (31) sur le bord extérieur du rebord faisant saillie (14), la première région (31) ayant une forme arrondie et s'étendant vers le haut, et **en ce que** une deuxième région (32) est intégralement formée sur la première région (31) de sorte que la deuxième région (32) est disposée essentiellement à angles droits par rapport à la surface du rebord faisant saillie (14), et **en ce que** une troisième région (33) est intégralement formée sur la deuxième région (32), la troisième région (33) ayant une forme arrondie, et **en ce que** une quatrième région (34) est intégralement formée sur la troisième région (33), la quatrième région (34) s'étendant essentiellement parallèlement à la deuxième région (32), et **en ce que** la quatrième région (32) est connectée au bord extérieur du rebord faisant saillie ou est libre. 25
  7. Emballage de portion selon la revendication 5 ou 6, **caractérisé en ce que** la deuxième région (32), la troisième région (33) et la quatrième région (34) peuvent être déformées par une région d'étanchéité correspondante (21) du dispositif de maintien vers le bas (2). 30
  8. Emballage de portion selon l'une des revendications 5 à 7, **caractérisé en ce que**, pendant l'opération de déformation, la quatrième région (34) est conduite dans l'intérieur de la forme arrondie de la première région (31). 35
  9. Emballage de portion selon la revendication 1, **caractérisé en ce que** le rebord de prolongement est intégralement formée sur le bord extérieur du rebord faisant saillie (14), et **en ce que** le rebord de prolongement a une région (41), ladite région (41) ayant une coupe transversale de forme essentiellement ronde. 40
  10. Emballage de portion selon la revendication 9, **caractérisé en ce que** le rebord de prolongement s'étend vers le haut et/ou vers le bas à partir du rebord faisant saillie. 45
  11. Emballage de portion selon l'une des revendications précédentes, **caractérisé en ce que** l'emballage de portion est fabriqué à partir d'aluminium ou d'un alliage d'aluminium. 50
  12. Emballage de portion selon la revendication 11, **caractérisé en ce que** l'emballage de portion comporte à l'intérieur et/ou à l'extérieur une couche composée de plastique. 55
  13. Emballage de portion selon l'une des revendications précédentes, **caractérisé en ce que** un capsule de portion a une épaisseur de paroi moyenne de 0,05 mm à 0,12 mm.
  14. Procédé pour produire un emballage de portion selon l'une des revendications précédentes, **caractérisé en ce que** la capsule de portion est produite selon une opération d'emboutissage.

15. Dispositif pour produire une boisson par extraction de celle-ci à partir d'une substance contenue dans un emballage de portion selon l'une des revendications 1 à 13, l'emballage de portion étant insérable dans le dispositif, comprenant au moins un dispositif de maintien vers le bas (2) et un pendant (4) avec une poinçonneuse (5), le dispositif de maintien vers le bas (2) et/ou le pendant (4) étant équipé de moyen (s) pour déformer l'élément d'étanchéité de l'emballage de portion,
- caractérisé en ce que** un creux (41) qui est complémentaire de l'élément d'étanchéité est disposé dans une région inférieure du dispositif de maintien vers le bas (2), et/ou **en ce que** un creux (41) qui est complémentaire de l'élément d'étanchéité est disposé dans le pendant, la ou les dépressions produisant la déformation d'étanchéité de l'emballage de portion.
16. Utilisation de l'emballage de portion selon la revendication 1 dans un dispositif selon la revendication 15 pour l'extraction d'une boisson.

5

10

15

20

25

30

35

40

45

50

55

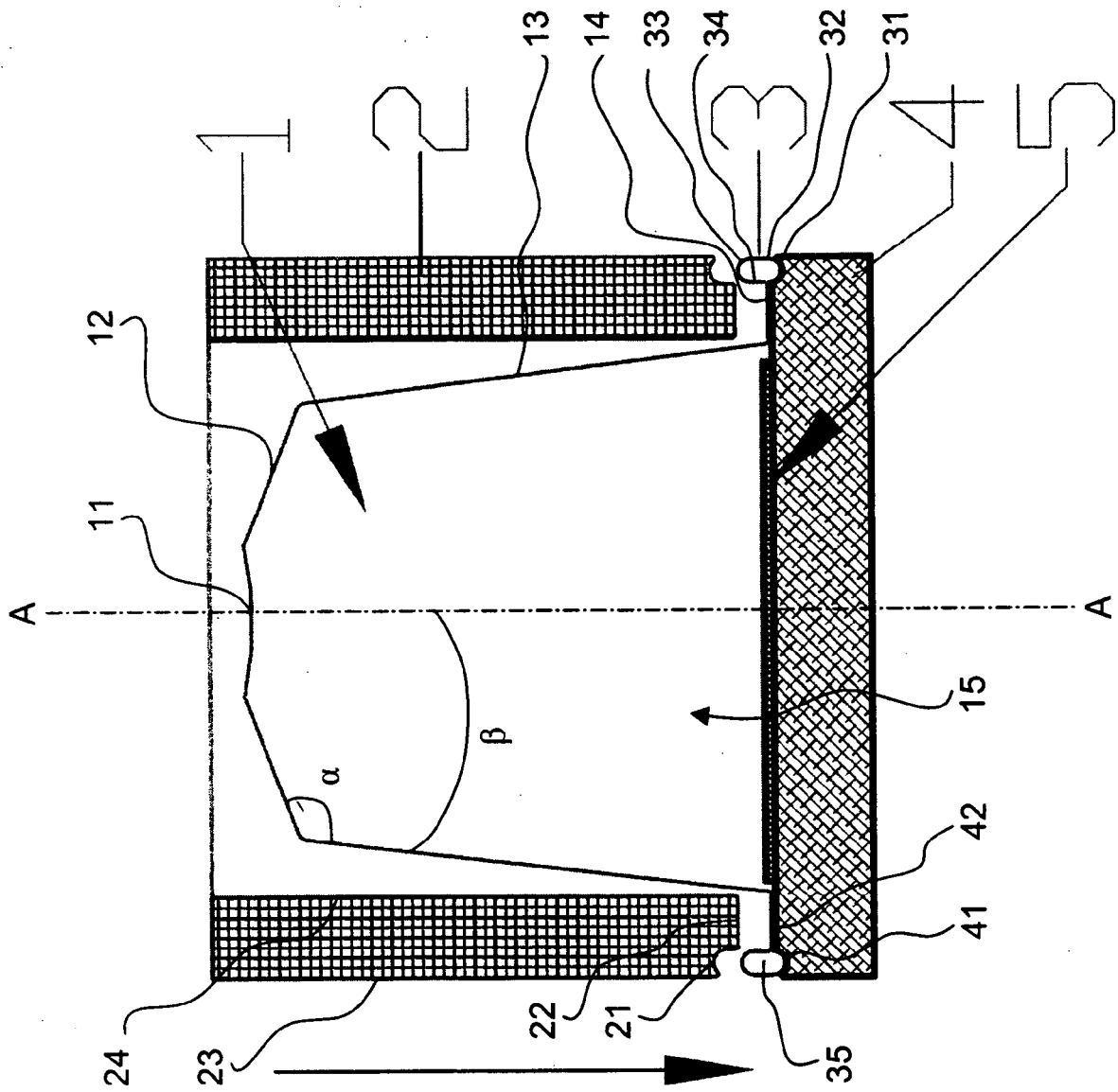

FIG. 1



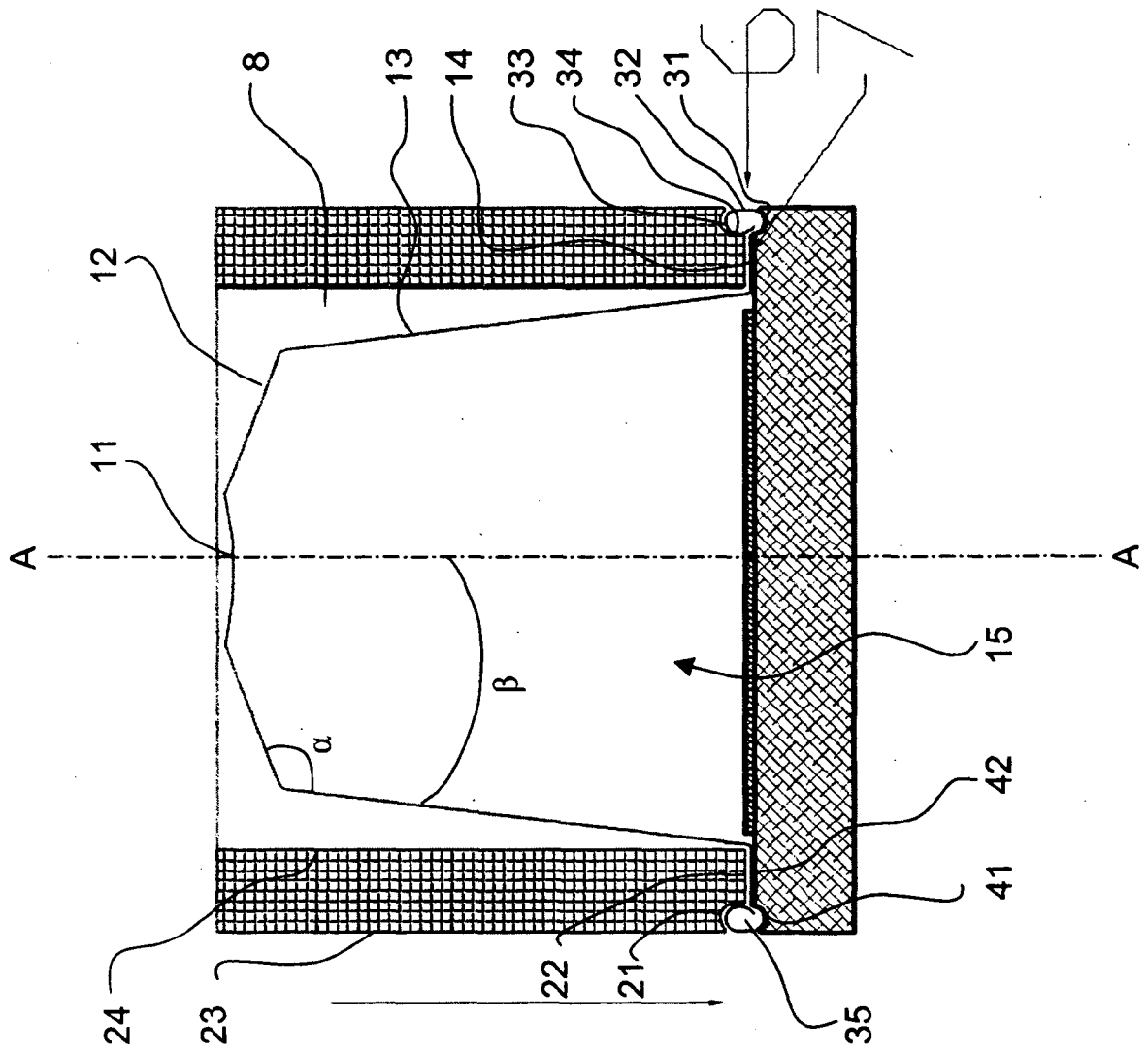

FIG. 3

**REFERENCES CITED IN THE DESCRIPTION**

*This list of references cited by the applicant is for the reader's convenience only. It does not form part of the European patent document. Even though great care has been taken in compiling the references, errors or omissions cannot be excluded and the EPO disclaims all liability in this regard.*

**Patent documents cited in the description**

- EP 0512470 A [0002]
- FR 2616389 [0004]
- EP 1654966 A1 [0005]