



(11) **EP 2 031 208 A8**

(12) **CORRECTED EUROPEAN PATENT APPLICATION**

(15) Correction information:
Corrected version no 1 (W1 A3)
Corrections, see
Bibliography INID code(s) 71

(51) Int Cl.:
F01P 5/02 (2006.01) **F04D 19/00** (2006.01)
F04D 29/32 (2006.01) **F04D 29/38** (2006.01)

(48) Corrigendum issued on:
06.02.2013 Bulletin 2013/06

(88) Date of publication A3:
14.11.2012 Bulletin 2012/46

(43) Date of publication A2:
04.03.2009 Bulletin 2009/10

(21) Application number: **08162261.5**

(22) Date of filing: **12.08.2008**

(84) Designated Contracting States:
AT BE BG CH CY CZ DE DK EE ES FI FR GB GR HR HU IE IS IT LI LT LU LV MC MT NL NO PL PT RO SE SI SK TR
Designated Extension States:
AL BA MK RS

(72) Inventors:
• **Paggi, Bruno**
24047 Treviglio (Bergamo) (IT)
• **Benzoni, Giuseppe**
24020 Fino del Monte (Bergamo) (IT)

(30) Priority: **21.08.2007 IT MI20071681**

(74) Representative: **Ottazzo, Marco Francesco**
Agostino et al
Barzanò & Zanardo Milano S.p.A.
Via Borgonuovo, 10
20121 Milano (IT)

(71) Applicant: **SAME DEUTZ-FAHR GROUP S.p.A.**
24047 Treviglio (Bergamo) (IT)

(54) **Axial fan for cooling the underhood of a farm machine**

(57) Herein described is an axial fan for cooling the underhood of a farm machine, of the type made up of a rotor (10) provided with a plurality of blades (12) with a wing profile and a substantially radial development constrained against the central hub (14) of the rotor (10) at one of their first ends. Each blade (12) is made up of a first element or main profile (18) and by at least a second element or flap (20) arranged in proximity to the inlet edge (18') of the first element or main profile (18). A blading profile of such type allows pitch setting the blades with considerable angles of attack and obtaining high dynamic values, avoiding the occurrence of separations of the boundary layer from the top layer of the blade profile itself at the same time.

Fig. 1

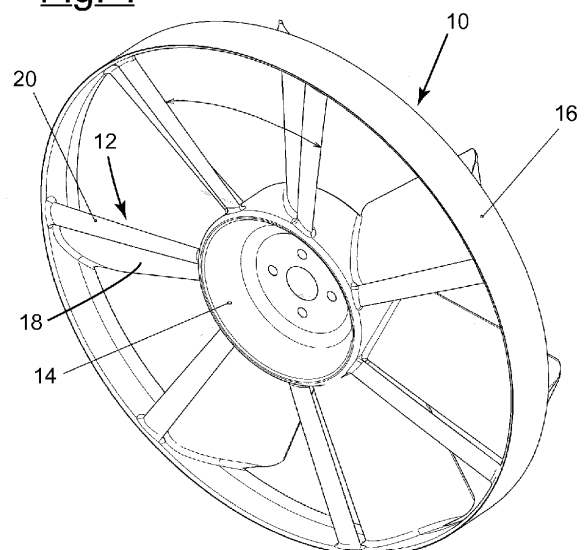

EP 2 031 208 A8