

(19)



(11)

**EP 2 033 690 A1**

(12)

**EUROPEAN PATENT APPLICATION**

(43) Date of publication:  
**11.03.2009 Bulletin 2009/11**

(51) Int Cl.:  
**A63B 22/02 (2006.01)**

(21) Application number: **07017525.2**

(22) Date of filing: **07.09.2007**

(84) Designated Contracting States:  
**AT BE BG CH CY CZ DE DK EE ES FI FR GB GR HU IE IS IT LI LT LU LV MC MT NL PL PT RO SE SI SK TR**

Designated Extension States:  
**AL BA HR MK RS**

(72) Inventor: **Wang, Leao**  
**Taiping City,**  
**Taichung Hsien,**  
**Taiwan 411 (TW)**

(74) Representative: **Reichel, Wolfgang**  
**Reichel und Reichel**  
**Parkstrasse 13**  
**60322 Frankfurt (DE)**

(71) Applicant: **Wang, Leao**  
**Taiping City,**  
**Taichung Hsien,**  
**Taiwan 411 (TW)**

**(54) Cushioning mechanism for a treadmill**

(57) A cushioning mechanism for a treadmill having a pair of C-shaped rigid connection elements (30) and a pair of pivotal rigid cushioning elements (40) that are interposed between the bottom surface of both sides of the platform frame (20) and the base bars (12). The pivotal rigid cushioning element (40) includes a guidewheel (41) at one end thereof. In this way, the guidewheel (41) is

movable on the surface of the base bar (12) when the platform frame (20) is moved up and down by the external forces applied to it. Accordingly, the cushioning and restoring effects can be achieved. Moreover, a resistance-adjusting element is provided at the bottom of the guidewheel (41). A free adjustment of the cushioning force may be achieved by the inclination of the resistance-adjusting element.

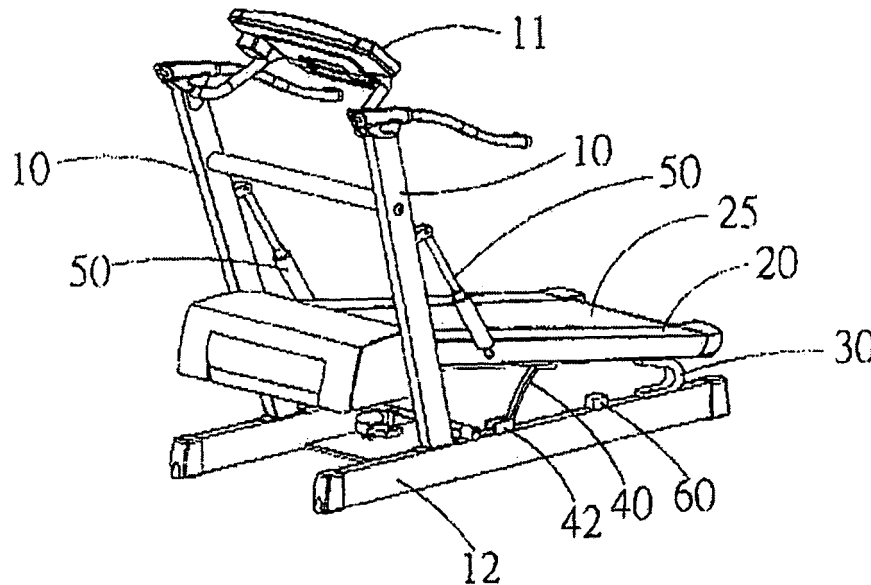

**FIG. 1**

**EP 2 033 690 A1**

**Description**

## BACKGROUND OF THE INVENTION

## 1. Field of the invention

**[0001]** The invention relates to a cushioning mechanism for a treadmill, and more particularly, to a cushioning mechanism having a compact configuration while achieving an optimal shock-absorbing effect.

## 2. Description of the Prior Art

**[0002]** A cushioning mechanism of a treadmill is adapted to support a platform frame. A vibration action is created when the platform frame is exposed to a continuous treading force by an operator thereon. A reaction force will, in turn, act on the feet of the operator, thereby giving him a little discomfort now and again. This discomfort can be relieved by the cushioning mechanism.

**[0003]** Accordingly, a few rows of resilient pads are provided between the platform frame and the base frame of the treadmill to achieve an expected shock-absorbing effect. Such a conventional configuration can be easily obtained from e.g. US 6077200, 5746682, etc.

**[0004]** However, the aforementioned construction is prone to trouble with respect to its assembly, maintenance, and replacement. In particular, the disassembly and assembly of the continuous moving belt and the platform often frustrate do-it-yourselfers during the maintenance of the treadmill. Finally, they often have no choice but to turn to professional mechanic for help.

**[0005]** It is an object of the present invention to provide a cushioning mechanism for a treadmill, ensuring a complete cushioning and restoring effect.

**[0006]** This object is achieved by a cushioning mechanism for a treadmill as indicated in independent claim 1.

**[0007]** Advantageous embodiments of the invention are defined in the dependent claims.

## SUMMARY OF THE INVENTION

**[0008]** Thus, based on the above described drawbacks of the prior art, the designer would like to employ a mechanism exposed to the outside of the main body of the treadmill for an easy assembly while achieving the same effects. In this way, maintenance and replacement operations can be considerably simplified. Thus, a pair of  $\supset$ -shaped rigid connection elements and a pair of pivotal rigid cushioning elements that are interposed between the bottom surface of both sides of the platform frame and the base bars. Moreover, an auxiliary supporting element is pivotally interposed between both sides of the platform frame and the handle frame assembly, respectively. As a result, a complete cushioning and restoring effect can be ensured. In this way, the drawbacks of the prior art in use can be eliminated. This is the main object of the invention.

**[0009]** Another object of the invention is to provide the means such that the user can adjust the cushioning force of the cushioning element by himself. In this way, the user can perform an operator-oriented adjustment according to personal operation habits for ensuring a comfortable operation. Accordingly, a resistance-adjusting element is provided at the bottom of the guidewheel. A free personal adjustment of the cushioning force may be achieved by the inclination of the resistance-adjusting element.

## BRIEF DESCRIPTION OF THE DRAWINGS

**[0010]** Preferred embodiments of the present invention will now be described in more detail with reference to the accompanying drawings, in which:

FIG. 1 is a perspective drawing of a preferred embodiment of the invention;

FIG. 2 is a side view of the resistance-adjusting element in accordance with the invention that is located in a nearly horizontal position;

FIG. 3 is an operational side view according to the state of FIG. 2;

FIG. 4 is a side view of the resistance-adjusting element in accordance with the invention that is located in an inclined position;

FIG. 5 is an operational side view according to the state of FIG. 4;

FIG. 6 is a schematic drawing of another preferred embodiment of the invention; and

FIG. 7 is a schematic drawing of a further preferred embodiment of the invention.

## DETAILED DESCRIPTION OF THE PREFERRED EMBODIMENT

**[0011]** Referring to FIGS. 1, 2 and 3, a treadmill in accordance with the invention includes a handle frame assembly 10 and a platform frame 20.

**[0012]** The handle frame assembly 10 is positioned at both sides of a front end of the platform frame 20. An electronic console 11 is installed at a top side of the handle frame assembly 10 while two base bars 12 are attached to a bottom end of the handle frame assembly 10.

**[0013]** The platform frame 20 is pivotally mounted near a bottom portion of the handle frame assembly 10. A continuous moving belt 25 works in cooperation with a motor 21, a belt 22, a front roller 23, and a rear roller 24 to ensure a circulating operation.

**[0014]** A pair of  $\supset$ -shaped rigid connection elements 30 and a pair of pivotal rigid cushioning elements 40 are

interposed between the bottom surface of both sides of the platform frame 20 and the base bars 12. The pivotal rigid cushioning element 40 includes a guidewheel 41 at one end thereof. In this way, the guidewheel 41 is movable on the surface of the base bar 12 when the platform frame 20 is moved up and down by the external forces applied to it (see FIG. 3 & Fig. 5). Accordingly, the cushioning and restoring effects can be achieved.

**[0015]** Moreover, a resistance-adjusting element 42 is provided at the bottom of the guidewheel 41. A free adjustment of the cushioning force may be achieved by the inclination of the resistance-adjusting element 42. An auxiliary supporting element 50 is pivotally interposed between both sides of the platform frame 20 and the handle frame assembly 10, respectively. As a result, a complete cushioning and restoring effect can be ensured.

**[0016]** In a few words, the sliding resistance created by the resistance adjusting element 42 and acting on the guidewheel 41 is smaller when the inclination of the resistance adjusting element 42 approaches to the horizontal position, as shown in FIGS. 2 and 3. To the contrary, the sliding resistance acting on the guidewheel 41 will be increased, as shown in FIGS. 4 and 5.

**[0017]** In addition, the  $\supset$ -shaped rigid connection elements 30 can also achieve the cushioning effect. In other words, the  $\supset$ -shaped rigid connection elements 30 regain their original shape after being compressed or deformed by the external forces applied thereto. Accordingly, an optimal cushioning action may be achieved by the cooperation of the  $\supset$ -shaped rigid connection elements 30, the pivotal rigid cushioning elements 40 and the auxiliary supporting elements 50.

**[0018]** In order to ensure the use safety, a soft stop element 60 can be attached to the surface of the base bars 12, respectively. In case of overload on the platform frame 20 or damage of relevant elements, the soft stop element 60 can act against the downward movement of the platform frame 20. In this way, the operator's safety can be assured.

**[0019]** Referring to FIG. 6, which is a schematic drawing of another preferred embodiment of the invention, the pivotal rigid cushioning element 40, may be made of a plurality of arched steel plates for increasing the whole strength. Likewise, the pivotal rigid cushioning elements 40 may be symmetrically designed in  $\cap$ -form for enhancing the whole effect thereof.

**[0020]** Many changes and modifications in the above-described embodiments of the invention can, of course, be carried out without departing from the scope thereof. Accordingly, to promote the progress in science and the useful arts, the invention is disclosed and is intended to be limited only by the scope of the appended claims.

## Claims

1. A cushioning mechanism for a treadmill comprising:

a) a handle frame assembly (10) positioned at both sides of a front end of a platform frame (20), an electronic console (11) being installed at a top side of the handle frame assembly (10) while two base bars (12) being attached to a bottom end thereof;

b) said platform frame (20) pivotally mounted near a bottom portion of the handle frame assembly (10), a continuous moving belt (25) working in cooperation with a motor (21), a belt (22), a front roller (23), and a rear roller (24) to ensure a circulating operation;

c) a pair of  $\supset$ -shaped rigid connection elements (30) and a pair of pivotal rigid cushioning elements (40) interposed between the bottom surface of both sides of the platform frame (20) and the base bars (12), the pivotal rigid cushioning elements (40) each having a guidewheel (41) at one end thereof such that the guidewheel (41) is movable on the surface of the base bar (12) when the platform frame (20) is moved up and down by the external forces applied to it;

d) a resistance-adjusting element (42) is provided at the bottom of the guidewheel (41) such that a free adjustment of the cushioning force may be achieved by the inclination of the resistance-adjusting element (42); and

e) an auxiliary supporting element (50) pivotally interposed between both sides of the platform frame (20) and the handle frame assembly (10), respectively.

2. The cushioning mechanism for an electric treadmill as claimed in claim 1 wherein a soft stop element (60) is attached to the surface of the base bars (12), respectively

3. The cushioning mechanism for an electric treadmill as claimed in claim 1 wherein a pivotal rigid cushioning element (40) is made of a plurality of arched steel plates.

4. The cushioning mechanism for an electric treadmill as claimed in claim 1 wherein the pivotal rigid cushioning elements (40) are symmetrically designed in  $\cap$ -form.

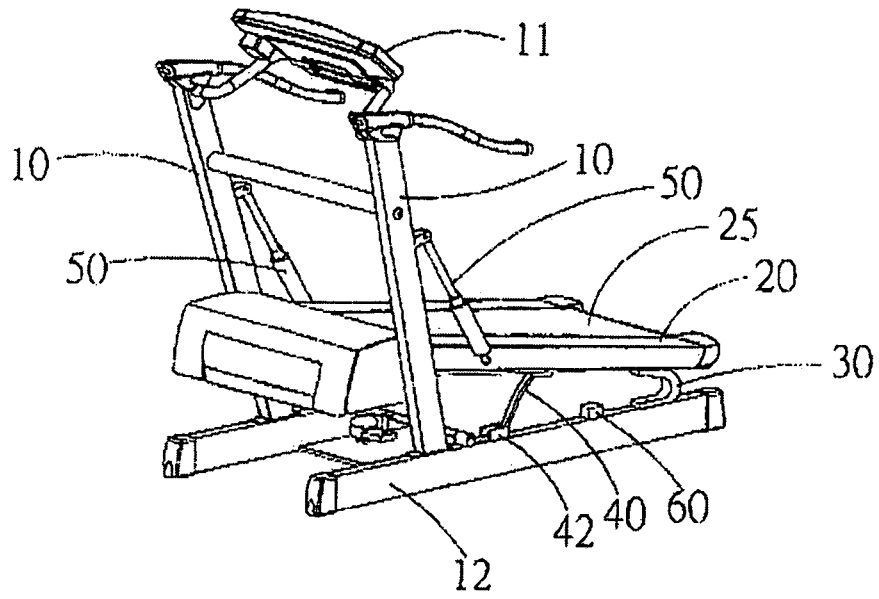

FIG.1

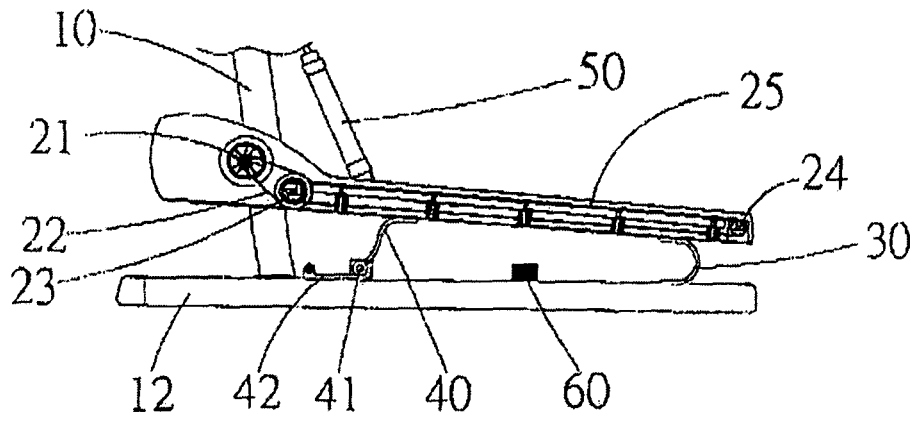

FIG. 2

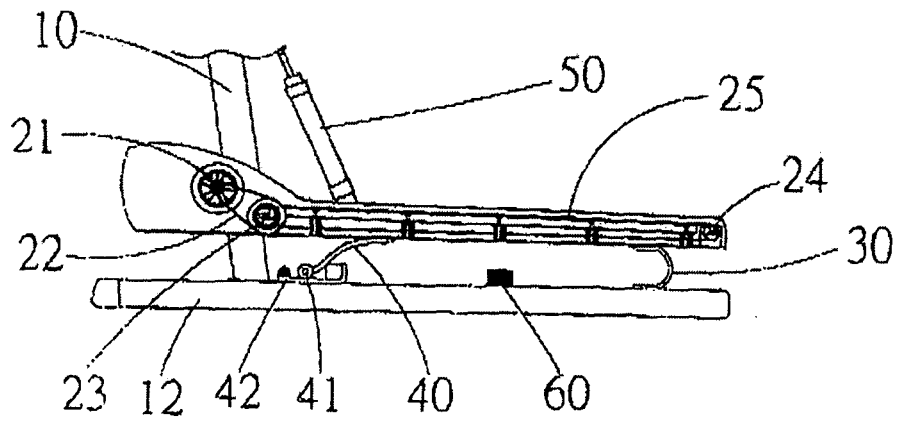

FIG. 3

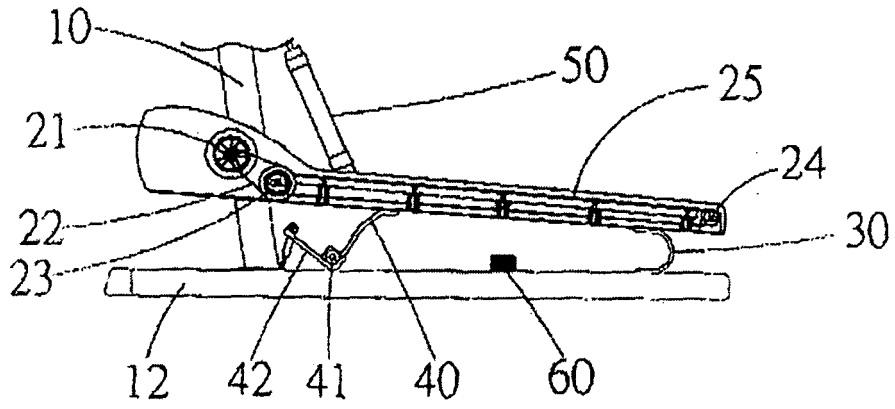

FIG. 4

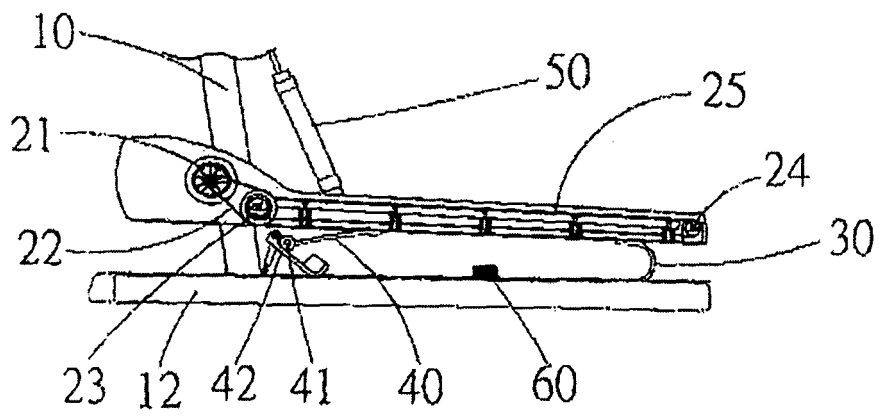

FIG. 5

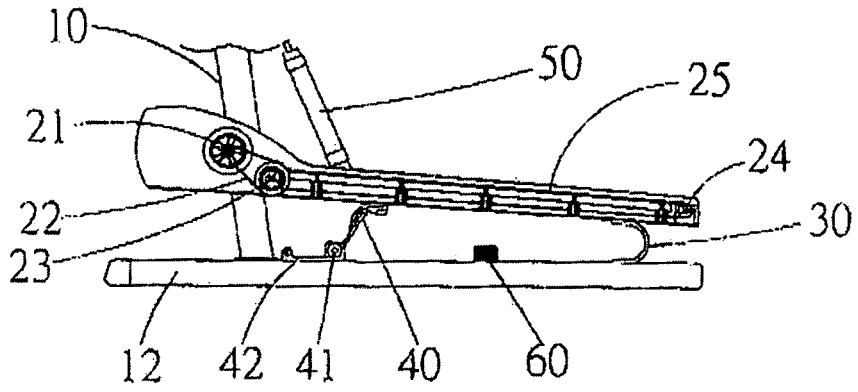

FIG. 6

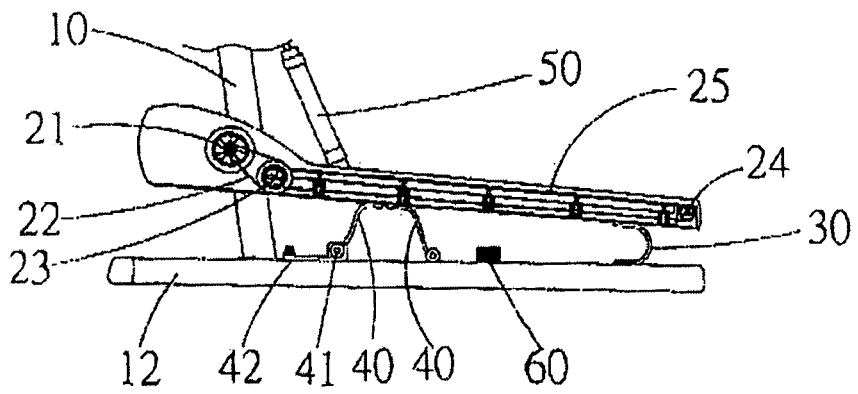

FIG. 7



| DOCUMENTS CONSIDERED TO BE RELEVANT   |   |   |   |
|---|---|---|---|
| Category  | Citation of document with indication, where appropriate, of relevant passages   | Relevant to claim   | CLASSIFICATION OF THE APPLICATION (IPC) |
| A   | EP 1 743 677 A (BRUNSWICK CORP [US])<br>17 January 2007 (2007-01-17)<br>* paragraph [0006] - paragraph [0007] *<br>* paragraph [0023] - paragraph [0024] *<br>* paragraph [0027] - paragraph [0028];<br>figures 1-6 * | 1-4   | INV.<br>A63B22/02                       |
| A   | DE 203 08 961 U1 (CHANG HUANG TUNG [TW])<br>21 August 2003 (2003-08-21)<br>* page 2, line 4 - line 10 *<br>* page 3, line 11 - page 4, line 1; figure 1 *   | 1-4   |   |
| A   | US 6 893 383 B1 (CHANG CHIH YUAN [TW] ET AL)<br>17 May 2005 (2005-05-17)<br>* column 2, line 35 - column 3, line 38;<br>figures 1,2,4 *   | 1-4   |   |
|   |   |   | TECHNICAL FIELDS SEARCHED (IPC)         |
|   |   |   | A63B                                    |
| The present search report has been drawn up for all claims  |   |   |   |
| Place of search   |   | Date of completion of the search  | Examiner                                |
| The Hague   |   | 28 January 2008   | Michels, Norbert                        |
| CATEGORY OF CITED DOCUMENTS   |   |   |   |
| X : particularly relevant if taken alone<br>Y : particularly relevant if combined with another document of the same category<br>A : technological background<br>O : non-written disclosure<br>P : intermediate document |   | T : theory or principle underlying the invention<br>E : earlier patent document, but published on, or after the filing date<br>D : document cited in the application<br>L : document cited for other reasons<br>.....<br>& : member of the same patent family, corresponding document |   |

2  
EPO FORM 1503 03.02 (P04C01)

**ANNEX TO THE EUROPEAN SEARCH REPORT  
ON EUROPEAN PATENT APPLICATION NO.**

EP 07 01 7525

This annex lists the patent family members relating to the patent documents cited in the above-mentioned European search report. The members are as contained in the European Patent Office EDP file on The European Patent Office is in no way liable for these particulars which are merely given for the purpose of information.

28-01-2008

| Patent document cited in search report | Publication date | Patent family member(s) | Publication date |
|--|------------------|-------------------------|------------------|
| EP 1743677                             | A                | CA 2550791 A1           | 15-01-2007       |
|  |                  | CN 1895701 A            | 17-01-2007       |
|  |                  | US 2007015636 A1        | 18-01-2007       |
| -----                                  |                  |                         |                  |
| DE 20308961                            | U1               | NONE                    |                  |
| -----                                  |                  |                         |                  |
| US 6893383                             | B1               | NONE                    |                  |
| -----                                  |                  |                         |                  |

EPO FORM P0459

For more details about this annex : see Official Journal of the European Patent Office, No. 12/82

**REFERENCES CITED IN THE DESCRIPTION**

*This list of references cited by the applicant is for the reader's convenience only. It does not form part of the European patent document. Even though great care has been taken in compiling the references, errors or omissions cannot be excluded and the EPO disclaims all liability in this regard.*

**Patent documents cited in the description**

- US 6077200 A [0003]
- US 5746682 A [0003]