

(19)



(11)

EP 2 033 693 A1

(12)

EUROPEAN PATENT APPLICATION

(43) Date of publication:
11.03.2009 Bulletin 2009/11

(51) Int Cl.:
A63B 51/14 (2006.01)

(21) Application number: **07115593.1**

(22) Date of filing: **04.09.2007**

(84) Designated Contracting States:
**AT BE BG CH CY CZ DE DK EE ES FI FR GB GR
 HU IE IS IT LI LT LU LV MC MT NL PL PT RO SE
 SI SK TR**
 Designated Extension States:
AL BA HR MK RS

• **Lin, Po-Hsiu**
Taipei City 106 (TW)

(72) Inventor: **Tsai-Tien, L**
804, Kaohsiung City (TW)

(74) Representative: **Chaillot, Geneviève et al**
Cabinet CHAILLOT,
B.P. No. 74
92703 Colombes Cédex (FR)

(71) Applicants:
 • **Li, Chun-Chieh**
Kaohsiung City 804 (TW)

(54) Height adjusting device for use in string pulling block of stringing machine

(57) A height adjusting device for use in string pulling block of string machine comprises a rod member (1) combining with a string pulling block (c) of the stringing machine for moving relative to the rod member (1), a titled coupling seat (2) mounted on the upper side of a base (a) of the stringing machine, wherein the coupling seat

(2) includes a rail (21) arranged thereon, with which the rod member (1) is axially connected for moving along the rail (21), such that a string inserted between a frame (d) and a string puller (c1) of the string pulling block (c) is in a horizontal state, thus avoiding the friction of the frame (d) and the string to protect the string and the frame (d) from harm.

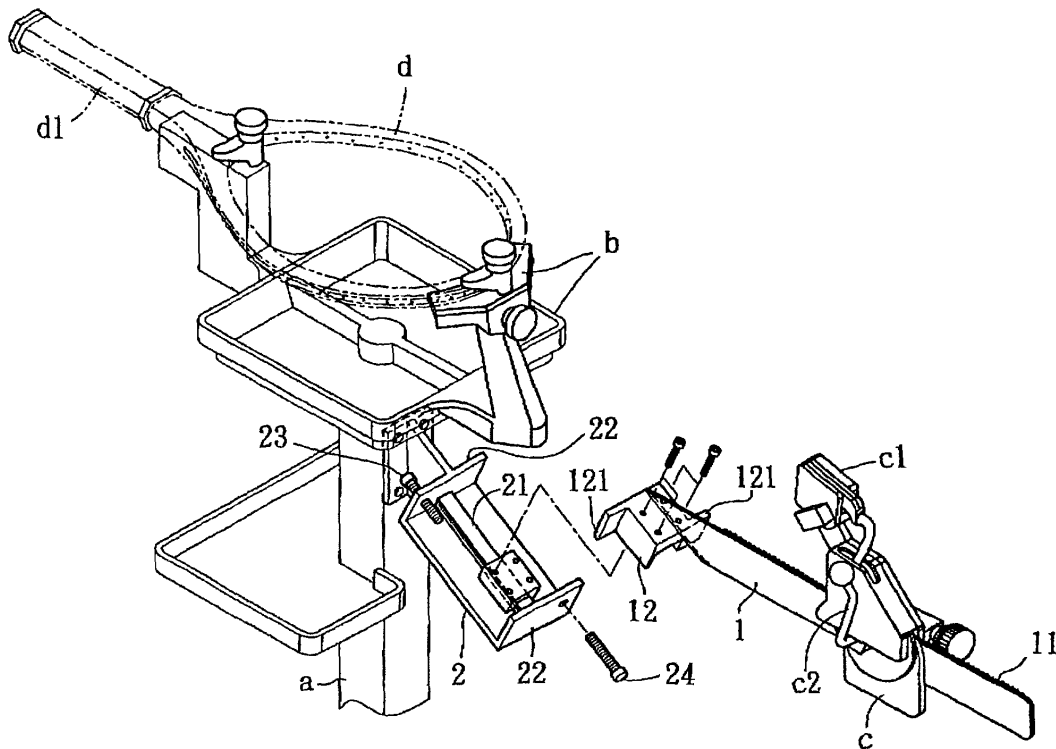

FIG. 5

EP 2 033 693 A1

Description**BACKGROUND OF THE INVENTION**Field of the Invention

[0001] The present invention relates to a height adjusting device for use in string pulling block of string machine that may improve the stringing quality and facilitate the height adjustment of the string pulling block.

Description of the Prior Arts

[0002] Tennis and badminton are both a healthy and intellectual sport. To develop the skill of playing tennis or badminton, a racket and strings with a precise pound number are both an indispensable winning factor in a tennis or badminton game. Besides, the string method of racket also influences the service lives of racket and strings.

[0003] A prior art string machine comprises a base a, a holder b and a string pulling block c (as shown in FIG. 1), wherein the holder b is axially connected to the top of the base a for 360 degree rotation and positioning, and the string pulling block c includes a string puller c1 and a lever c2 both arranged thereon. A rod member 10 for combining with the string pulling block c is coupled onto the upper side of the base a (as illustrated in FIG. 2) and includes racks 101 arranged thereon, such that the string pulling block c may move along the racks 11. In other words, the string pulling block c may move relative to the rod member 10.

[0004] In operation, the frame d is supported by the holder b, and the string e is fixed between the string puller c1 of the string pulling block c and the frame d (as shown in FIG. 2), thereafter, the pound number of the string is set, and by rotating the lever c2, the set pound number of the string is achieved, thereby assembling the longitudinal and lateral strings e of the frame d in turns.

[0005] However, such a prior art string machine still has the following defects:

1. Easily harming the frame d and the string e: Since the various kinds of frames d are not provided with the same thickness, yet the heights of the holders b and the string pulling blocks c are fixed, after inserting the string e between the string puller c1 of the string pulling block c and the frame d, causing an included angle θ therebetween (as illustrated in FIG. 2), hence as pulling the string e, the force of the frame d is unequal because of a friction, obtaining an imprecise pound number. Furthermore, the string e or the frame d is easily broken because of the friction between the through holes formed in the frame d and the string e.

2. Disadvantageous operation: Since the various kinds of frames d are not provided with the same thickness, yet the heights of the holders b and the

string pulling blocks c are fixed, during the rotation of the frame d, a grip d1 of the frame d contacts with the string puller c1 (as illustrated in FIGS. 3 and 4), resulting in an disadvantageous operation.

[0006] The present invention has arisen to mitigate and/or obviate the afore-described disadvantages.

SUMMARY OF THE INVENTION

[0007] The primary object of the present invention is to provide a height adjusting device for use in string pulling block of string machine that may protect strings and a frame from harm.

[0008] Another object of the present invention is to provide a height adjusting device for use in string pulling block of string machine that may avoid the contact of the frame and a string puller during the rotation of the frame.

[0009] In accordance with one aspect of the present invention, there is provided a height adjusting device for use in string pulling block of string machine comprising a rod member and a coupling seat, and the string machine including a base, a holder and a string pulling block (its structure is the same as above-mentioned description, therefore further remarks would be omitted), wherein

the rod member is constructed in the form of an elongated plate for combining with the string pulling block and includes racks arranged thereon such that the string pulling block may move along the racks, and includes a tilted sliding member, cross section of which is in the shape of an inverted U, coupled at one end thereof and having two biasing tabs disposed at the cater-cornered sides thereof

the tilted coupling seat is mounted on the upper side of the base of the stringing machine and includes a rail arranged thereon, by using the sliding member, the rod member is axially connected with the rail for obliquely moving along the rail upward and downward, thus adjusting the height of the string pulling block, in addition, the coupling seat including two side plates for corresponding to each other is used to receive the rail therein such that the sliding member may be limited to slide on the rail between the two sides of the sliding member, one of the side plates contains a micro-adjustable screw screwed therein, and another of the side plates involves an adjusting screw screwed therein, and the micro-adjustable screw and the adjusting screw are in response to the biasing tabs of the sliding member individually.

[0010] In assembly, a frame is supported by the holder, and a string is fixed between a string puller of the string pulling block and the frame. Thereafter, the pound number of the string is set, in the meantime, since the string is in an extension state, the sliding member of the rod member obliquely moves upward by way of the string pulling block, thereby the string inserted between the frame and the string puller is almost in a horizontal state, and one of the biasing tabs abuts against the micro-ad-

justable screw of the coupling seat, then the micro-adjustable screw is rotated for having a micro adjustment to let the string become horizontal. Finally, by rotating a lever, the set pound number of the string is obtained, thus assembling the longitudinal and lateral strings e of the frame d in turns.

[0011] If turning the frame to face the string, the string outside the frame becomes loose, therefore the sliding member obliquely and downwardly moves toward another biasing tab which is biased against the adjusting screw of the coupling seat. To avoid a grip contacting with the string puller of the string pulling block during the rotation of the frame, the adjusting screw is rotated, simultaneously, the heights of the sliding member, the rod member and the string pulling block are descended without causing the grip to contact with the string puller, facilitating rotation in different directions.

[0012] The present invention will become more obvious from the following description when taken in connection with the accompanying drawings, which show, for purpose of illustrations only, the preferred embodiment in accordance with the present invention.

BRIEF DESCRIPTION OF THE DRAWINGS

[0013]

FIG. 1 is a perspective diagram illustrating the exploded components of a prior art string machine;
 FIG. 2 is a side diagram illustrating an angle occurring between a frame of the prior art string machine and a string;
 FIG. 3 is a top plane diagram illustrating a grip contacting with a string puller of a string pulling block after the rotation of the frame of the prior art string machine;
 FIG. 4 is a side diagram according to FIG. 3;
 FIG. 5 is a perspective diagram illustrating the exploded components of a height adjusting device for use in string pulling block of string machine according to the present invention;
 FIG. 6 is an assembly side diagram illustrating a rod member of the height adjusting device for use in string pulling block of string machine according to the present invention moving upward;
 FIG. 7 is an operational side diagram of the height adjusting device for use in string pulling block of string machine according to the present invention;
 FIG. 8 is an assembly side diagram illustrating the rod member of the height adjusting device for use in string pulling block of string machine according to the present invention moving downward.

DETAILED DESCRIPTION OF THE PREFERRED EMBODIMENT

[0014] Referring to FIG. 5, a height adjusting device for use in string pulling block of string machine in accord-

ance with the present invention comprises a rod member 1 and a coupling seat 2, and the string machine including a base a, a holder b and a string pulling block c (its structure is the same as above-mentioned description, therefore further remarks would be omitted), wherein the rod member 1 (as shown in FIGS. 5 and 6) is constructed in the form of an elongated plate for combining with the string pulling block c and includes racks 11 arranged thereon, such that the string pulling block c may move along the racks 11, and includes a tilted sliding member 12, cross section of which is in the shape of an inverted U, coupled at one end thereof and having two biasing tabs 121 disposed at the cater-cornered sides thereof (as illustrated in FIG. 5);

the titled coupling seat 2 (as shown in FIGS. 5 and 6) is mounted on the upper side of the base a of the stringing machine and includes a rail 21 arranged thereon, by using the sliding member 12, the rod member 1 is axially connected with the rail 21 for obliquely moving along the rail 21 upward and downward (as illustrated in FIG. 7), thus adjusting the height of the string pulling block c, in addition, the coupling seat 2 including two side plates 22 for corresponding to each other is used to receive the rail 21 therein such that the sliding member 12 may be limited to slide on the rail 21 between the two sides 22 of the sliding member 12, one of the side plates 22 contains a micro-adjustable screw 23 screwed therein, and another of the side plates 22 involves an adjusting screw 24 screwed therein, and the micro-adjustable screw 23 and the adjusting screw 24 are in response to the biasing tabs 121 of the sliding member 12 individually.

[0015] In assembly, a frame d is supported on the holder b, and a string e is fixed between a string puller c 1 of the string pulling block c and the frame d (as shown in FIG. 6). Thereafter, the pound number of the string is set, in the meantime, since the string e is in an extension state, the sliding member 12 of the rod member 1 obliquely moves upward by way of the string pulling block c, thereby the string e inserted between the frame d and the string puller c1 is almost in a horizontal state, and one of the biasing tabs 121 abuts against the micro-adjustable screw 23 of the coupling seat 2, then the micro-adjustable screw 23 is rotated for having a micro adjustment to let the string e become horizontal. Finally, by rotating a lever c2, the set pound number of the string e is obtained, thus assembling the longitudinal and lateral strings of the frame d in turns.

[0016] If turning the frame d to face the string e, the string e outside the frame d becomes loose, therefore the sliding member 12 obliquely and downwardly moves toward another biasing tab 121 which is biased against the adjusting screw 24 of the coupling seat 2 (as shown in FIG. 8). To avoid a grip d1 contacting with the string puller c1 of the string pulling block c during the rotation of the frame d, the adjusting screw 24 is rotated, simultaneously, the heights of the sliding member 12, the rod member 1 and the string pulling block c are descended without causing the grip d1 to contact with the string puller

c1 facilitating rotation in different directions.

[0017] It can be clearly seen from the preceding accounts on the features of the present invention that the height adjusting device for use in string pulling block of string machine of the present invention has the following advantages:

1. Protecting the string e and the frame d from harm: Since the heights of the rod member 1, the string pulling block c may be adjustable, enabling to adjust the frame d to move at different heights, such that the string e inserted between the frame d and the string puller c 1 is in a horizontal state. In other words, no any angle occurs between the frame d and the string e, thus avoiding the contact of the string e and the through holes formed in the frame d, and the friction of the frame d and string e.

2. Avoiding the contact of the frame d and the string puller c1 during the rotation of the frame d, accordingly by rotating the adjusting screw 24 backward, the heights of the sliding member 12, the rod member 1 and the string pulling block c may be further descended, and the grip d1 doesn't contact with the string puller c1 of the string pulling block c, facilitating the rotation in different directions.

[0018] On the other hand, the micro adjustments of the heights of the sliding member 12, the rod member 1 and the string pulling block c may be achieved by means of an electronic controlling system, causing a precise position.

[0019] The invention is not limited to the above embodiment but various modifications thereof may be made. It will be understood by those skilled in the art that various changes in form and detail may made without departing from the scope and spirit of the present invention.

Claims

1. A height adjusting device for use in string pulling block of string machine comprising:

a rod member (1) combining with a string pulling block (c) of the stringing machine for moving relative to said rod member (1), a titled coupling seat (2) mounted on the upper side of a base (a) of the stringing machine, wherein said coupling seat (2) includes a rail (21) arranged thereon, with which said rod member (1) is axially connected for moving along said rail (21), thereby adjusting the height of said string pulling block (c).

2. The height adjusting device for use in string pulling block of string machine as claimed in claim 1, wherein said rod member (1) includes a titled sliding member (12), cross section of which is in the shape of an

inverted U, coupled at one end thereof and may be limited to slide on said rail (21).

3. The height adjusting device for use in string pulling block of string machine as claimed in claim 2, wherein said sliding member (12) includes two biasing tabs (121) disposed at the cater-cornered sides thereof.

4. The height adjusting device for use in string pulling block of string machine as claimed in claim 1, wherein said coupling seat (2) including two side plates (22) for corresponding to each other is used to receive said rail (21) therein.

5. The height adjusting device for use in string pulling block of string machine as claimed in claim 4, wherein one of said side plates (22) contains a micro-adjustable screw (23) screwed therein, and another of said side plates (22) involves an adjusting screw (24) screwed therein.

6. The height adjusting device for use in string pulling block of string machine as claimed in claim 5, wherein said micro-adjustable screw (23) and said adjusting screw (24) are in response to said biasing tabs (121) of said sliding member (12) individually.

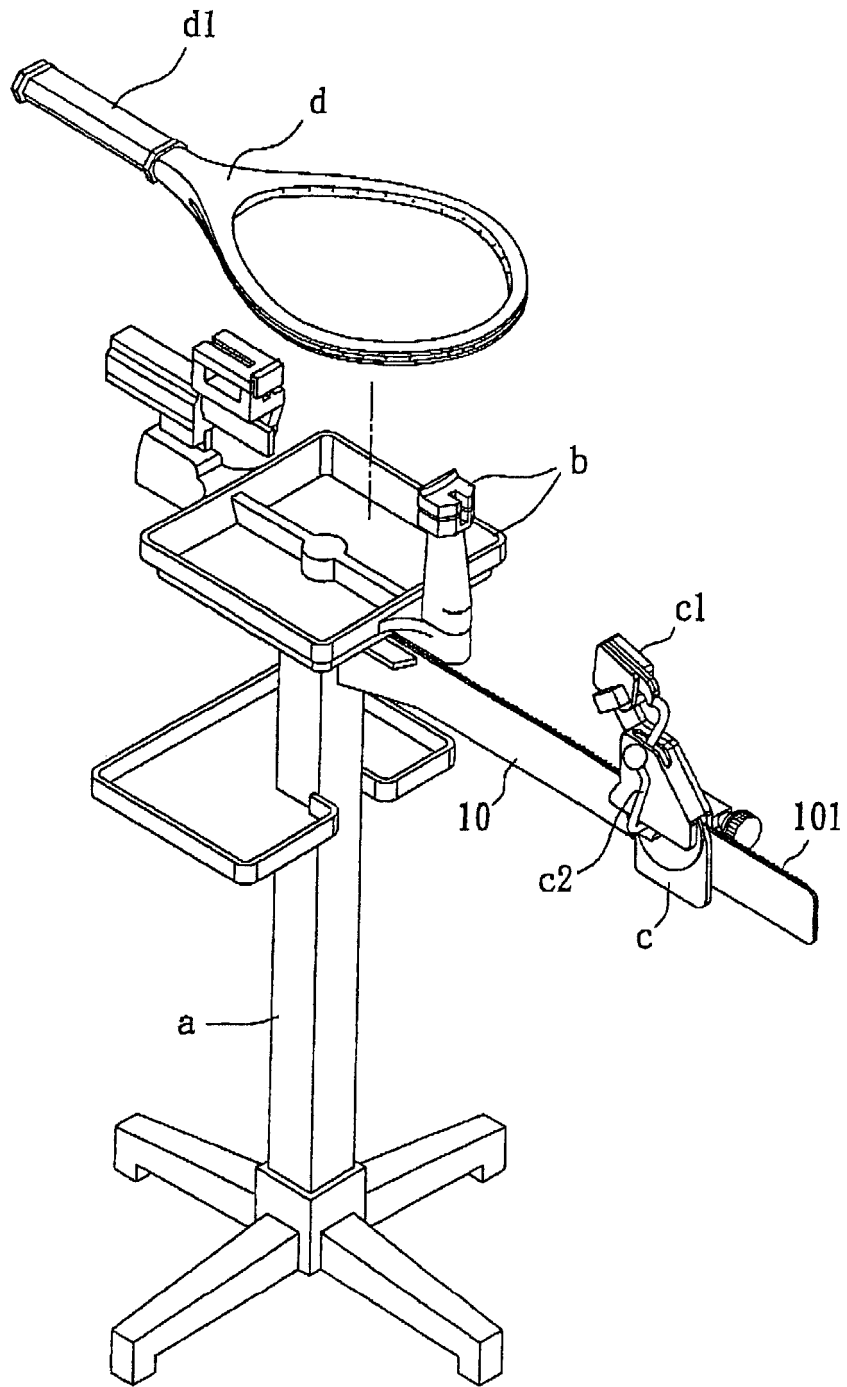

FIG. 1
PRIOR ART

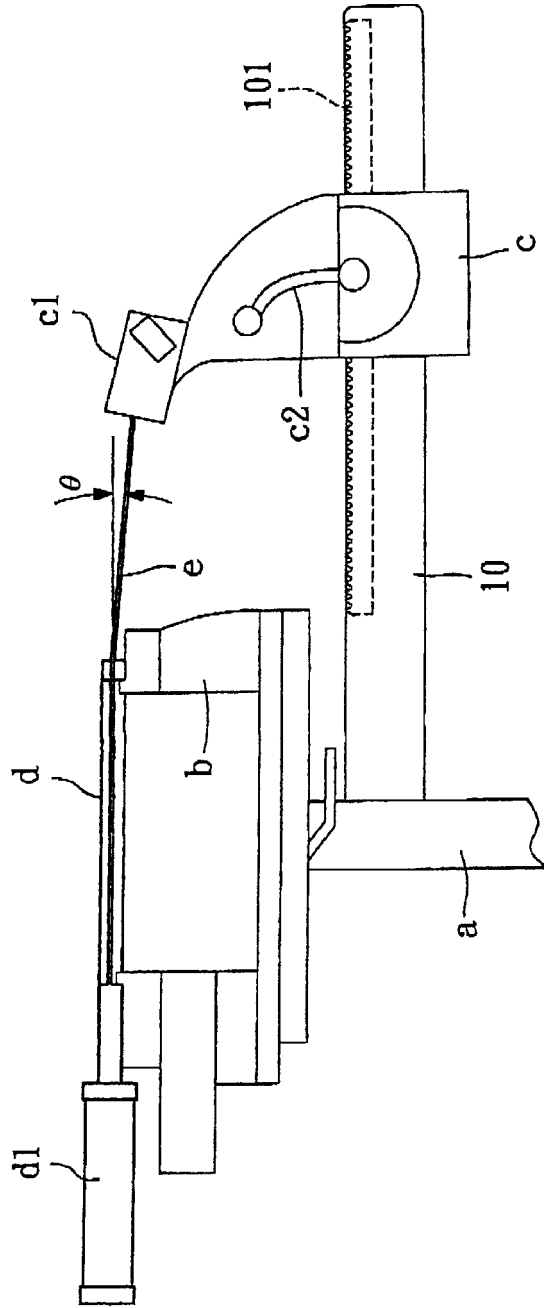

FIG. 2
PRIOR ART

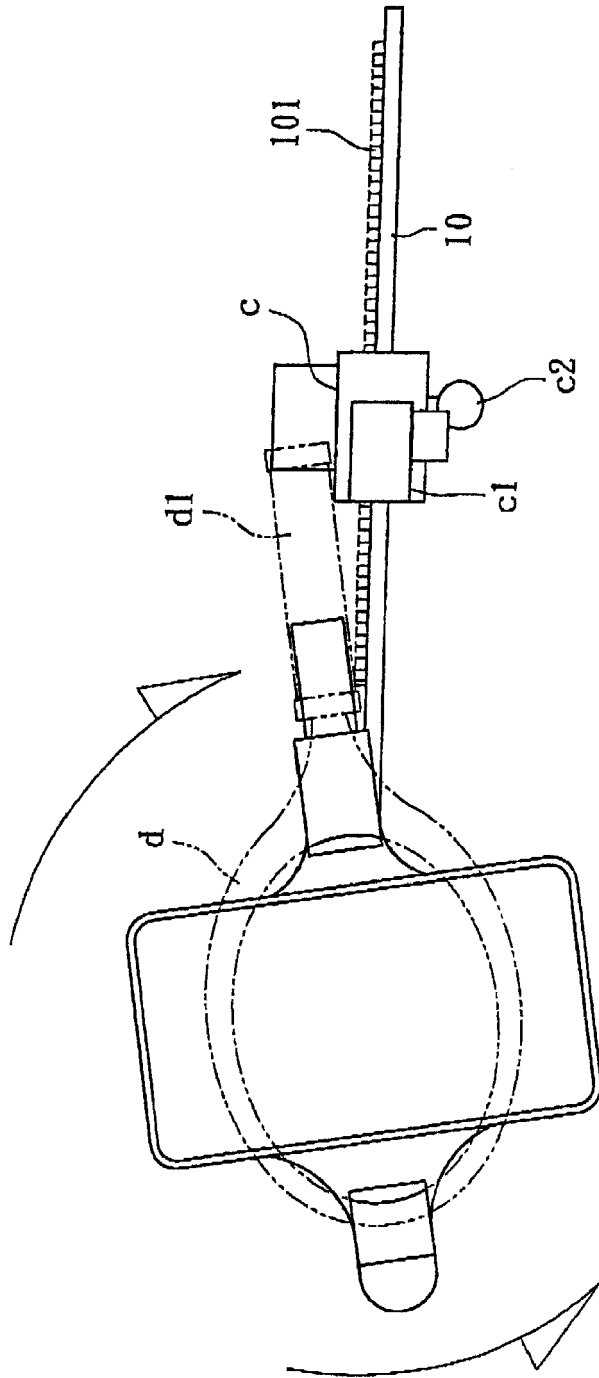

FIG. 3
PRIOR ART

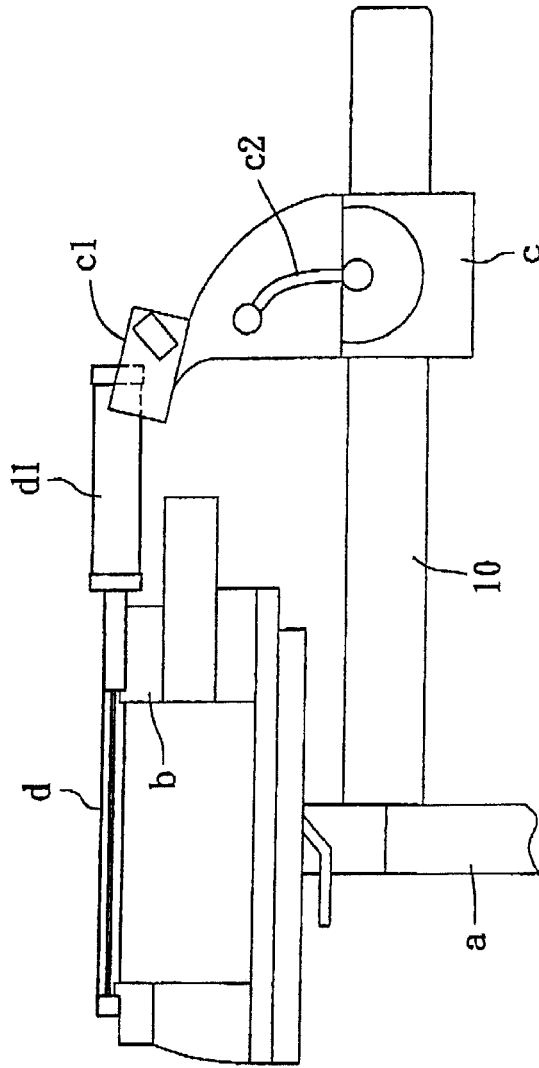

FIG. 4

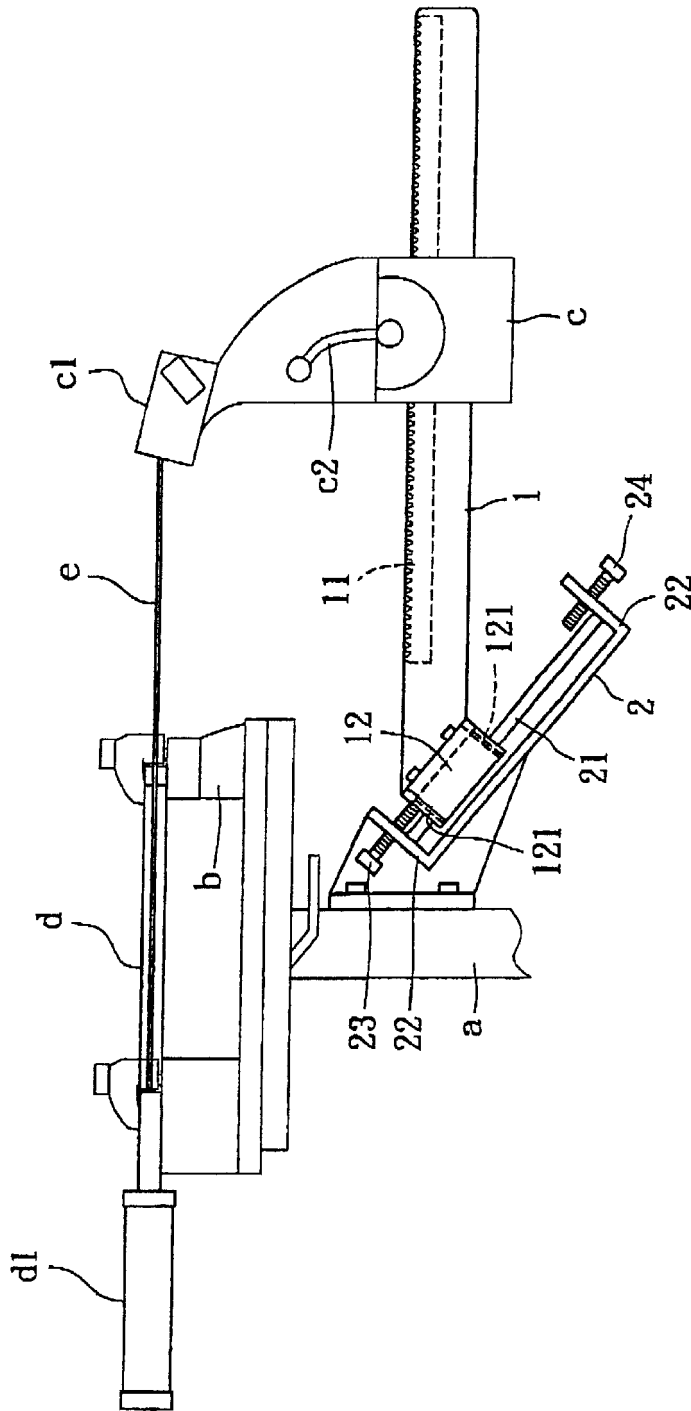

FIG. 6

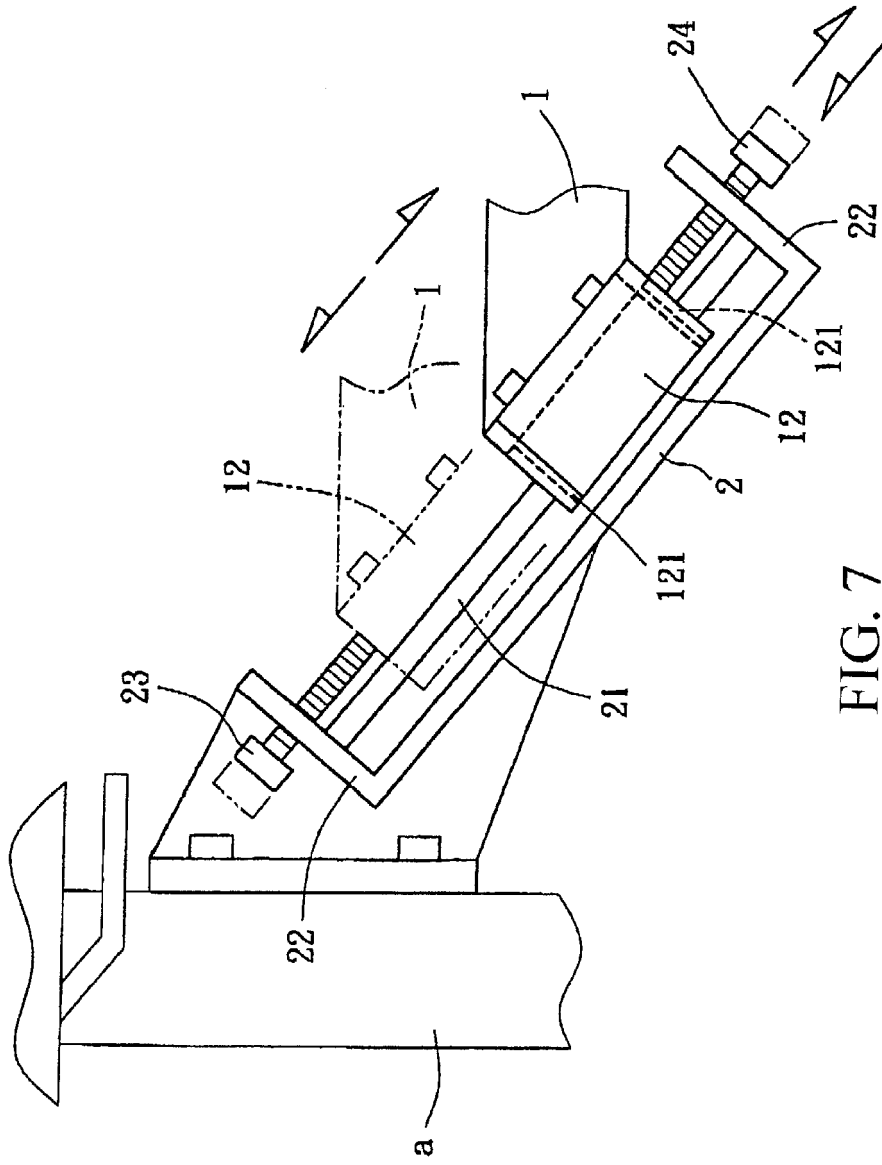

FIG. 7

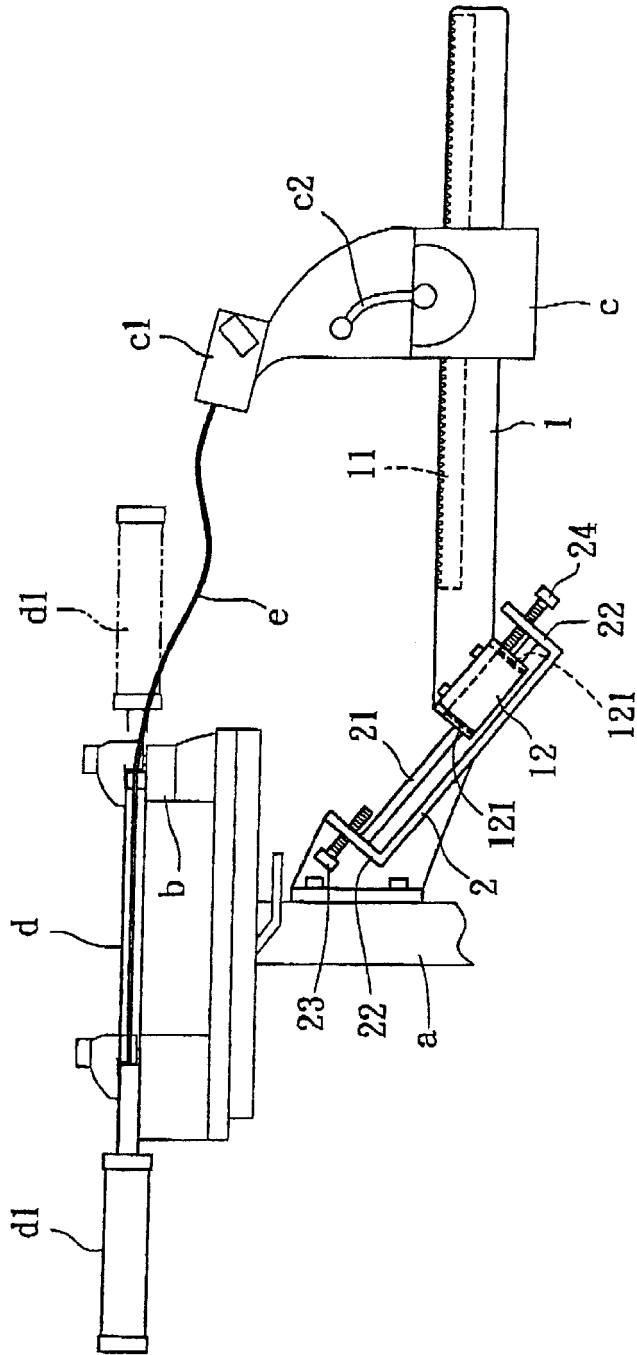

FIG. 8



DOCUMENTS CONSIDERED TO BE RELEVANT			
Category	Citation of document with indication, where appropriate, of relevant passages	Relevant to claim	CLASSIFICATION OF THE APPLICATION (IPC)
A	US 5 733 212 A (WISE HERBERT H [US] ET AL) 31 March 1998 (1998-03-31) * figure 15 *	1	INV. A63B51/14
A	----- WO 95/11728 A (PRINCE SPORTS GROUP INC [US]) 4 May 1995 (1995-05-04) * abstract; figures 5,7 * -----	1	
			TECHNICAL FIELDS SEARCHED (IPC)
			A63B
The present search report has been drawn up for all claims			
Place of search		Date of completion of the search	Examiner
The Hague		10 January 2008	Tejada Biarge, Diego
<p>CATEGORY OF CITED DOCUMENTS</p> <p>X : particularly relevant if taken alone Y : particularly relevant if combined with another document of the same category A : technological background O : non-written disclosure P : intermediate document</p> <p>T : theory or principle underlying the invention E : earlier patent document, but published on, or after the filing date D : document cited in the application L : document cited for other reasons & : member of the same patent family, corresponding document</p>			

2

EPO FORM 1503 03/82 (P04/C01)

**ANNEX TO THE EUROPEAN SEARCH REPORT
ON EUROPEAN PATENT APPLICATION NO.**

EP 07 11 5593

This annex lists the patent family members relating to the patent documents cited in the above-mentioned European search report. The members are as contained in the European Patent Office EDP file on The European Patent Office is in no way liable for these particulars which are merely given for the purpose of information.

10-01-2008

Patent document cited in search report	Publication date	Patent family member(s)	Publication date
US 5733212 A	31-03-1998	AU 732425 B2	26-04-2001
		AU 4735197 A	05-05-1998
		EP 0942775 A1	22-09-1999
		US 6227990 B1	08-05-2001
		WO 9815323 A1	16-04-1998

WO 9511728 A	04-05-1995	AU 8090194 A	22-05-1995
		US 5568921 A	29-10-1996

EPO FORM P0459

For more details about this annex : see Official Journal of the European Patent Office, No. 12/82