



(11) **EP 2 033 740 A3**

(12) **EUROPEAN PATENT APPLICATION**

(88) Date of publication A3:  
**20.05.2009 Bulletin 2009/21**

(51) Int Cl.:  
**B25B 23/10 (2006.01)**

(43) Date of publication A2:  
**11.03.2009 Bulletin 2009/11**

(21) Application number: **08252647.6**

(22) Date of filing: **07.08.2008**

(84) Designated Contracting States:  
**AT BE BG CH CY CZ DE DK EE ES FI FR GB GR HR HU IE IS IT LI LT LU LV MC MT NL NO PL PT RO SE SI SK TR**  
Designated Extension States:  
**AL BA MK RS**

- **Parel, Thomas**  
**Anderson, South Carolina 29621 (US)**
- **Macias, Lilia**  
**Anderson, South Carolina 29621 (US)**
- **Evatt, Thomas**  
**Six Mile, South Carolina 29682 (US)**
- **Harrison, Ryan**  
**Anderson, South Carolina 29621 (US)**
- **Ohi, Taku**  
**Greer, South Carolina 29650 (US)**

(30) Priority: **09.08.2007 US 964123 P**  
**01.08.2008 US 184562**

(71) Applicant: **Techtronic Industries Company Limited**  
**Tsuen Wan, New Territories (HK)**

(74) Representative: **Martin, David John et al**  
**Marks & Clerk LLP**  
**5th Floor**  
**14 South Parade**  
**Leeds**  
**LS1 5QS (GB)**

(72) Inventors:  
• **McCraken, Robert**  
**Anderson, South Carolina 29625 (US)**

(54) **Screw guide**

(57) A screw guide (10) and a method of driving a screw (48) into a work surface utilizing a driving tool (11) and a screw guide (10). The screw guide (10) having a body (12) configured to be coupled with a rotating clamp

(14) of the rotary tool, the body (12) defining a chamber for receiving a screw (48), and a support member (16) coupled with the body (12) and configured to maintain the screw (48) in an orientation substantially parallel with the axis (18) of the rotating clamp (14).

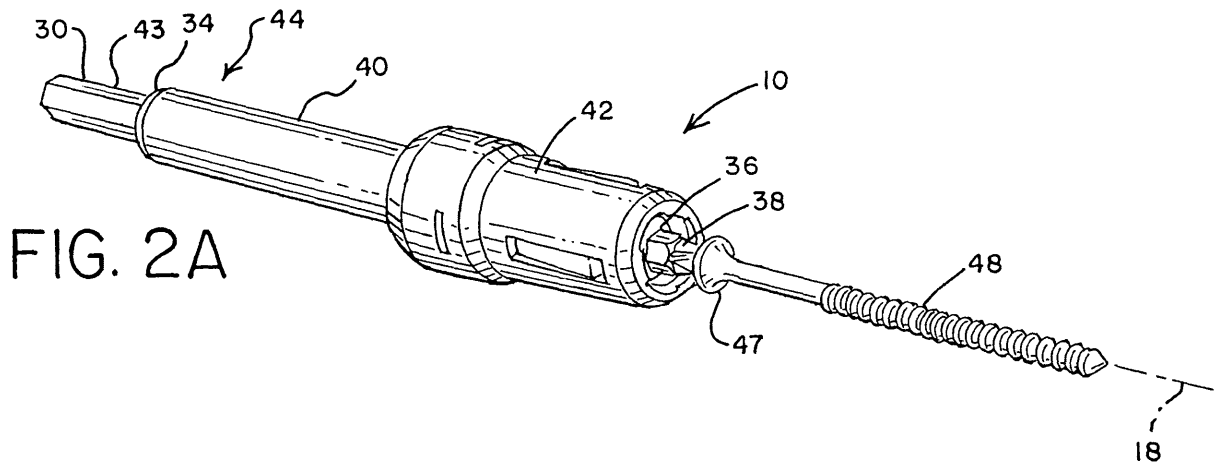

**FIG. 2A**

**EP 2 033 740 A3**



EUROPEAN SEARCH REPORT

Application Number  
EP 08 25 2647

DOCUMENTS CONSIDERED TO BE RELEVANT			
Category	Citation of document with indication, where appropriate, of relevant passages	Relevant to claim	CLASSIFICATION OF THE APPLICATION (IPC)
X	US 5 791 207 A (AHD00T NED M [US]) 11 August 1998 (1998-08-11) * claim 1 * * column 2, line 17 * * column 3, line 24 * * figures 1-4 *	1-4, 19	INV. B25B23/10
A		8,9,21, 22	
X	----- US 3 965 950 A (MACDONALD MURDO A) 29 June 1976 (1976-06-29) * column 1, line 30 * * column 3, lines 50-61 * * figures 1,6-9 *	1,5, 20-22	
A		11	
X	----- FR 1 388 819 A (ROHM GUENTER HORST) 12 February 1965 (1965-02-12) * claim 2 * * column 2, line 15 * * figure *	1	
A		11	
A	----- DE 12 41 380 B (ALFRED SCHLOTTER; HORST WEISSENHORN) 24 May 1967 (1967-05-24) * figures 1,2 * * the whole document * -----	1	TECHNICAL FIELDS SEARCHED (IPC) B25B B23P
6 The present search report has been drawn up for all claims			
Place of search The Hague		Date of completion of the search 15 April 2009	Examiner Klein, A
CATEGORY OF CITED DOCUMENTS X : particularly relevant if taken alone Y : particularly relevant if combined with another document of the same category A : technological background O : non-written disclosure P : intermediate document		T : theory or principle underlying the invention E : earlier patent document, but published on, or after the filing date D : document cited in the application L : document cited for other reasons ..... & : member of the same patent family, corresponding document	

EPO FORM 1503 03 82 (P04G01)

**ANNEX TO THE EUROPEAN SEARCH REPORT  
ON EUROPEAN PATENT APPLICATION NO.**

EP 08 25 2647

This annex lists the patent family members relating to the patent documents cited in the above-mentioned European search report. The members are as contained in the European Patent Office EDP file on The European Patent Office is in no way liable for these particulars which are merely given for the purpose of information.

15-04-2009

Patent document cited in search report		Publication date	Patent family member(s)	Publication date
US 5791207	A	11-08-1998	NONE	
-----				
US 3965950	A	29-06-1976	NONE	
-----				
FR 1388819	A	12-02-1965	NONE	
-----				
DE 1241380	B	24-05-1967	BE 607060 A1	01-12-1961
			CH 393222 A	31-05-1965
-----				

EPO FORM P0459

For more details about this annex : see Official Journal of the European Patent Office, No. 12/82