

(19)



(11)

EP 2 042 462 A1

(12)

EUROPEAN PATENT APPLICATION

(43) Date of publication:
01.04.2009 Bulletin 2009/14

(51) Int Cl.:
B66B 11/00 (2006.01) B66B 11/08 (2006.01)

(21) Application number: **09150612.1**

(22) Date of filing: **12.09.2000**

(84) Designated Contracting States:
CH DE FR LI NL

(72) Inventor: **Mitsui, Atsushi**
Tokyo 100-8310 (JP)

(62) Document number(s) of the earlier application(s) in accordance with Art. 76 EPC:
00957123.3 / 1 319 627

(74) Representative: **HOFFMANN EITLE**
Patent- und Rechtsanwälte
Arabellastraße 4
81925 München (DE)

(71) Applicant: **Mitsubishi Denki Kabushiki Kaisha**
Chiyoda-ku
Tokyo, 100-8310 (JP)

Remarks:

This application was filed on 15-01-2009 as a divisional application to the application mentioned under INID code 62.

(54) **Elevator apparatus**

(57) An elevator apparatus comprising:
 a hoistway (31) having a hoistway wall (31a to 31c)
 a driving machine (36) disposed in an upper portion inside said hoistway (31), having:
 a driving machine body (37); and
 a drive sheave (36) rotated by said driving machine body (37) around
 a rotating shaft extending in a vertical direction;
 a main rope having a car (34) end portion and a counterweight end portion secured to an upper portion inside said hoistway (31), an intermediate portion being wound around said drive sheave (38)
 a car (34) having mutually opposite first and second side surfaces (34a,34b), being suspended inside said hoistway (31) by said main rope (39) between said drive sheave (39) and said car end portion (39a) so as to be raised and lowered inside said hoistway (31) by said driving machine (36);
 a counterweight (35) disposed between said first side surface and said hoistway wall, being suspended inside said hoistway (31) by said main rope (39) between said drive sheave (38) and said counterweight end portion so as to be raised and lowered inside said hoistway (31) by said driving machine (36).

FIG. 7

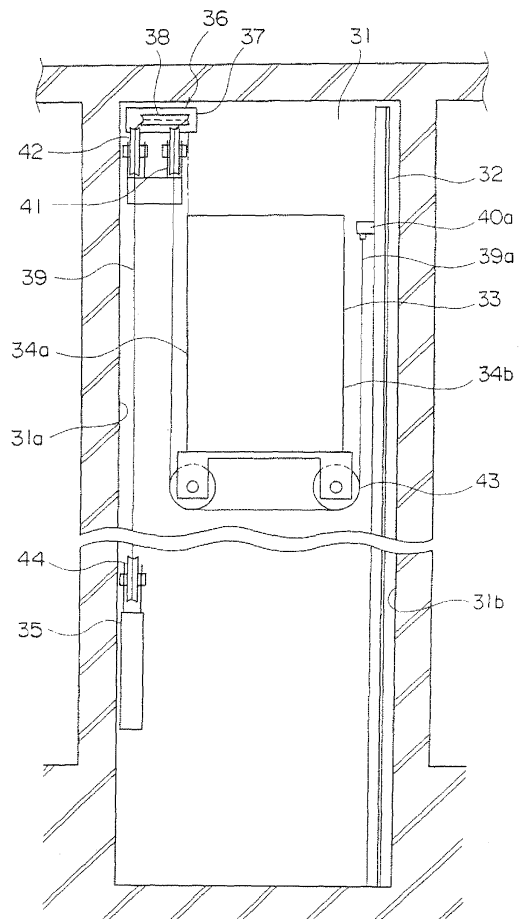

EP 2 042 462 A1

Description

TECHNICAL FIELD

[0001] The present invention relates to an elevator apparatus in which a driving machine is disposed in an upper portion inside a hoistway.

BACKGROUND ART

[0002] Conventional machine-roomless elevators of a type in which a driving machine is disposed in a pit in a hoistway are often adopted. However, in this type, countermeasures against flooding of the pit have been required.

[0003] In contrast to this, in a type in which the driving machine is disposed in an upper portion inside the hoistway, particularly in the case of one-to-one roping, if the position of the center of gravity of a car is to be suspended, it is necessary to ensure proportionate space between the car and a top portion of the hoistway since the main ropes are connected to an upper beam of the car, increasing the height dimensions of the hoistway.

DISCLOSURE OF THE INVENTION

[0004] The present invention aims to solve the above problems and an object of the present invention is to provide an elevator apparatus enabling increases in height dimensions of a hoistway to be suppressed while disposing a driving machine in an upper portion inside the hoistway.

[0005] According to one aspect of the present invention, there is provided an elevator apparatus including: a hoistway having a hoistway wall; a driving machine disposed in an upper portion inside the hoistway, having: a driving machine body; and a drive sheave rotated by the driving machine body around a rotating shaft extending in a vertical direction; a main rope group wound around the drive sheave; and a car and a counterweight suspended inside the hoistway by the main rope group so as to be raised and lowered inside the hoistway by the driving machine, wherein first and second main rope connection portions are disposed on the car so as to be positioned on opposite sides of the car in a vertical plane of projection, first and second car return sheaves are disposed above the first and second main rope connection portions in an upper portion inside the hoistway, a counterweight return sheave is disposed above the counterweight in an upper portion inside the hoistway, and the main rope group has a first main rope, a first end portion of which passes through the first car return sheave and is connected to the first main rope connection portion and a second end portion of which passes through the counterweight return sheave and is connected to the counterweight, and a second main rope, a first end portion of which passes through the second car return sheave and is connected to the second main rope con-

nection portion and a second end portion of which passes through the counterweight return sheave and is connected to the counterweight.

[0006] According to another aspect of the present invention, there is provided an elevator apparatus including: a hoistway having a hoistway wall; a driving machine disposed in an upper portion inside the hoistway, having: a driving machine body; and a drive sheave rotated by the driving machine body around a rotating shaft extending in a vertical direction; a main rope having a car end portion and a counterweight end portion secured to an upper portion inside the hoistway, an intermediate portion being wound around the drive sheave; a car having mutually opposite first and second side surfaces, being suspended inside the hoistway by the main rope between the drive sheave and the car end portion so as to be raised and lowered inside the hoistway by the driving machine; a counterweight disposed between the first side surface and the hoistway wall, being suspended inside the hoistway by the main rope between the drive sheave and the counterweight end portion so as to be raised and lowered inside the hoistway by the driving machine; a car return sheave disposed in an upper portion inside the hoistway and around which the main rope is wound, for guiding the main rope from the drive sheave to the car; and a counterweight return sheave disposed in an upper portion inside the hoistway and around which the main rope is wound, for guiding the main rope from the drive sheave to the counterweight, wherein the driving machine is disposed above a corner portion of a rear portion of the car on a side near the counterweight, and the car and counterweight return sheaves are disposed above a space between the first side surface and the hoistway wall.

BRIEF DESCRIPTION OF THE DRAWINGS

[0007]

Figure 1 is a general plan showing an elevator apparatus according to Embodiment 1 of the present invention;
 Figure 2 is a side elevation showing the elevator apparatus in Figure 1;
 Figure 3 is a perspective showing a construction of first and second main ropes from Figure 1;
 Figure 4 is a general plan showing an elevator apparatus according to Embodiment 2 of the present invention;
 Figure 5 is a side elevation showing the elevator apparatus in Figure 4;
 Figure 6 is a general plan showing an elevator apparatus according to Embodiment 3 of the present invention; and
 Figure 7 is a side elevation showing the elevator apparatus in Figure 6.

BEST MODE FOR CARRYING OUT THE INVENTION

[0008] Preferred embodiments of the present invention will now be explained with reference to the drawings.

Embodiment 1

[0009] Figure 1 is a general plan showing an elevator apparatus according to Embodiment 1 of the present invention, and Figure 2 is a side elevation showing the elevator apparatus in Figure 1.

[0010] In the figures, a hoistway 1 has hoistway walls 1a to 1c. A pair of car guide rails 2 and a pair of counterweight guide rails 3 are installed inside the hoistway 1. A car 4 is guided by the car guide rails 2 so as to be raised and lowered inside the hoistway 1. A counterweight 5 is guided by the counterweight guide rails 3 so as to be raised and lowered inside the hoistway 1. The counterweight 5 is disposed behind the car 4.

[0011] A driving machine (a hoisting machine) 6 for raising and lowering the car 4 and the counterweight 5 is disposed horizontally in an upper portion inside the hoistway 1. The driving machine 6 is disposed above a first corner portion of a rear portion of the car 4. The driving machine 6 also has a driving machine body 7 and a drive sheave 8. The drive sheave 8 is rotated by the driving machine body 7 around a rotating shaft extending in a vertical direction.

[0012] First and second main rope connection portions 9 and 10 are disposed on both sides of a lower portion of the car 4. The first and second main rope connection portions 9 and 10 are disposed symmetrically about the position of the center of gravity of the car 4 so as to be positioned on opposite sides of the car 4 in a vertical plane of projection.

[0013] First and second car return sheaves 11 and 12 are disposed in an upper portion inside the hoistway 1 above the first and second main rope connection portions 9 and 10. A counterweight return sheave 13 is disposed in an upper portion inside the hoistway 1 above the counterweight 5. These return sheaves 11 to 13 are each rotatable around a rotating shaft extending in a horizontal direction.

[0014] The first and second car return sheaves 11 and 12 are disposed between the hoistway walls 1a and 1b and a region projected vertically from the car 4, and the first and second car return sheaves 11 and 12 are parallel to each of the hoistway walls 1a and 1b. A direction-changing pulley 14 rotatable around a rotating shaft extending in a vertical direction is disposed above a second corner portion of the rear portion of the car 4.

[0015] A main rope group 15 for suspending the car 4 and the counterweight 5 inside the hoistway 1 is wound around the drive sheave 8. The main rope group 15 has a plurality of first main ropes 16 and a plurality of second main ropes 17. These main ropes 16 and 17 are each composed of a synthetic fiber rope.

[0016] First end portions of the first main ropes 16 pass

through the first car return sheave 11 and are connected to the first main rope connection portion 9, and second end portions pass through the counterweight return sheave 13 and are connected to an upper portion of the counterweight 5. First end portions of the second main ropes 17 pass through the direction-changing pulley 14 and the second car return sheave 12 and are connected to the second main rope connection portion 10, and second end portions pass through the counterweight return sheave 13 and are connected to an upper portion of the counterweight 5.

[0017] In other words, the first main ropes 16 and the second main ropes 17 connected to the counterweight 5 are branched off in two directions at the drive sheave 8 and connected to the car 4.

[0018] Figure 3 is a perspective showing a construction of the first and second main ropes 16 and 17 from Figure 1. In the figure, an inner strand layer 24 having a plurality of inner strands 22 and filler strands 23 disposed in gaps between these inner strands 22 is disposed around a core wire 21. Each of the inner strands 22 is composed of a plurality of aramid fibers and an impregnating material such as polyurethane or the like. The filler strands 23 are composed of a polyamide, for example.

[0019] An outer strand layer 26 having a plurality of outer strands 25 is disposed around an outer circumference of the inner strand layer 24. Each of the outer strands 25 is composed of a plurality of aramid fibers and an impregnating material such as polyurethane or the like in a similar manner to the inner strands 22.

[0020] A friction-reducing coating layer 27 for preventing abrasion of the strands 22 and 25 due to friction among the strands 22 and 25 in the sheaves such as the drive sheave 11, etc., is disposed between the inner strand layer 24 and the outer strand layer 26. A protective coating layer 28 is also disposed on an outer circumferential portion of the outer strand layer 26.

[0021] The car 4 and the counterweight 5 are suspended inside the hoistway 1 by a plurality of main ropes 12 having the above construction. The synthetic fiber rope has a high coefficient of friction compared to a steel rope and is superior in flexibility.

[0022] In an elevator apparatus of this kind, because the main rope group 15 is distributed into the first and second main ropes 16 and 17, and the car 4 is suspended by the first and second main rope connection portions 9 and 10 disposed on both sides thereof, the car 4 can be stably suspended at its center of gravity.

[0023] Furthermore, since the first and second main rope connection portions 9 and 10 are disposed on both sides of the car 4, it is not necessary to dispose connection portions for the main rope group 15 on an upper portion of the car 4. Consequently, the dimensions of the upper portion of the car 4 can be reduced, enabling suppression of increases in height dimensions of the hoistway 1 while disposing the driving machine 6 in the upper portion inside the hoistway 1.

[0024] In addition, because the first and second car

return sheaves 11 and 12 are disposed between the hoistway walls 1a and 1b and the region projected vertically from the car 4, the first and second car return sheaves 11 and 12 do not come into contact with the car 4. Consequently, increases in height dimensions of the hoistway 1 can be suppressed.

[0025] Increases in height dimensions of the hoistway 1 can be further suppressed if lower ends of the first and second car return sheaves 11 and 12 are disposed so as to be lower than a car ceiling position when the car 4 is positioned at a maximum point of upward motion, .

[0026] Furthermore, since the counterweight 5 is disposed behind the car 4, the driving machine 6 is disposed above the first corner portion of the rear portion of the car 4, and the direction-changing pulley 14 is disposed above the second corner portion of the rear portion of the car 4, the equipment can be disposed utilizing space inside the hoistway 1 effectively and can be easily adapted to changes in frontage dimensions and depth dimensions of the car 4.

[0027] Because first and second main ropes 16 and 17 composed of a synthetic fiber rope having a high coefficient of friction and superior flexibility are used, diameters of the drive sheave 8, the return sheaves 11 to 13, and the pulley 14 can be reduced, enabling suppression of increases in height dimensions of the hoistway 1.

Embodiment 2

[0028] Figure 4 is a general plan showing an elevator apparatus according to Embodiment 2 of the present invention, and Figure 5 is a side elevation showing the elevator apparatus in Figure 4.

[0029] In the figures, a first direction-changing pulley 18 rotatable around a rotating shaft extending in a vertical direction is disposed above the second corner portion of the rear portion of the car 4. The first and second main ropes 16 and 17 are wound around the first direction-changing pulley 18 and are branched off at the first direction-changing pulley 18.

[0030] A second direction-changing pulley 19 rotatable around a rotating shaft extending in a vertical direction is disposed between the first direction-changing pulley 18 and the first car return sheave 11. The first main ropes 16 pass from the first direction-changing pulley 18, through the second direction-changing pulley 19 and the first car return sheave 11, and are connected to the first main rope connection portion 9. The rest of the construction is similar to that of Embodiment 1.

[0031] In an elevator apparatus of this kind, since the first and second main ropes 16 and 17 are branched off at the first direction-changing pulley 18, in addition to effects similar to those of Embodiment 1, winding angles of the first and second main ropes 16 and 17 onto the drive sheave 8 can be made the same, and sufficient winding angles can be achieved.

Embodiment 3

[0032] Figure 6 is a general plan showing an elevator apparatus according to Embodiment 3 of the present invention, and Figure 7 is a side elevation showing the elevator apparatus in Figure 6.

[0033] In the figures, a hoistway 31 has hoistway walls 31a to 31c. A pair of car guide rails 32 and a pair of counterweight guide rails 33 are installed inside the hoistway 31. A car 34 is guided by the car guide rails 32 so as to be raised and lowered inside the hoistway 31. The car 34 has mutually opposite first and second side surfaces 34a and 34b.

[0034] A counterweight 35 is guided by the counterweight guide rails 33 so as to be raised and lowered inside the hoistway 31. The counterweight 35 is disposed between the first side surface 34a of the car 34 and the hoistway walls 31a.

[0035] A driving machine (a hoisting machine) 36 for raising and lowering the car 34 and the counterweight 35 is disposed horizontally in an upper portion inside the hoistway 31. The driving machine 36 is disposed above a first corner portion of a rear portion of the car 34. The driving machine 36 also has a driving machine body 37 and a drive sheave 38. The drive sheave 38 is rotated by the driving machine body 37 around a rotating shaft extending in a vertical direction.

[0036] The car 34 and the counterweight 35 are suspended inside the hoistway 31 by main ropes 39 composed of a synthetic fiber rope. The main ropes 39 have car end portions 39a and counterweight end portions 39b secured to car and counterweight rope fastener portions 40a and 40b in an upper portion inside the hoistway 31, intermediate portions being wound around the drive sheave 38. The construction of the main ropes 39 is similar to that in Figure 3.

[0037] The car 34 is suspended inside the hoistway 31 by the main ropes 39 between the drive sheave 38 and the car end portions 39a. The counterweight 35 is suspended inside the hoistway 31 by the main ropes 39 between the drive sheave 38 and the counterweight end portions 39b.

[0038] A car return sheave 41 for guiding the main ropes 39 from the drive sheave 38 to the car 34 and a counterweight return sheave 42 for guiding the main ropes 39 from the drive sheave 38 to the counterweight 35 are disposed in upper portions inside the hoistway 31. The car and counterweight return sheaves 41 and 42 are disposed above a space between the first side surface 34a of the car 34 and the hoistway wall 31a.

[0039] A pair of rotatable car suspension sheaves 43 around which the main ropes 39 are wound are disposed on a lower portion of the car 34. A rotatable counterweight suspension sheave 44 around which the main ropes 39 are wound is disposed on an upper portion of the counterweight 35.

[0040] In an elevator apparatus of this kind, since the car and counterweight return sheaves 41 and 42 are dis-

posed between the first side surface 34a of the car 34 and the hoistway wall 31a in a vertical plane of projection, planar dimensions of the hoistway 31 can be reduced. Furthermore, winding angles of the main ropes 39 onto the drive sheave 38 can be sufficiently ensured.

5

PREFERRED EMBODIMENTS OF THE INVENTION

[0041]

1. An elevator apparatus comprising:

a hoistway having a hoistway wall;
a driving machine disposed in an upper portion inside said hoistway, having:

10

a driving machine body; and
a drive sheave rotated by said driving machine body around

15

a rotating shaft extending in a vertical direction;
a main rope group wound around said drive sheave; and
a car and a counterweight suspended inside said hoistway by said main rope group so as to be raised and lowered inside said hoistway by said driving machine,

20

25

wherein first and second main rope connection portions are disposed on said car so as to be positioned on opposite sides of said car in a vertical plane of projection,
first and second car return sheaves are disposed above said first and second main rope connection portions in an upper portion inside said hoistway,
a counterweight return sheave is disposed above said counterweight in an upper portion inside said hoistway, and
said main rope group has:

30

35

a first main rope, a first end portion of which passes through said first car return sheave and is connected to said first main rope connection portion and a second end portion of which passes through said counterweight return sheave and is connected to said counterweight; and
a second main rope, a first end portion of which passes through said second car return sheave and is connected to said second main rope connection portion and a second end portion of which passes through said counterweight return sheave and is connected to said counterweight.

40

45

50

2. The elevator apparatus according to 1, wherein said first and second car return sheaves are disposed between said hoistway wall and a region projected vertically from said car.

55

3. The elevator apparatus according to 2, wherein said counterweight is disposed behind said car, and said driving machine is disposed above a first corner portion of a rear portion of said car.

4. The elevator apparatus according to 3, wherein a direction-changing pulley being rotatable around a rotating shaft extending in a vertical direction is disposed in an upper portion inside said hoistway, said first and second main ropes are branched off at said drive sheave, and said second main rope is wound around said direction-changing pulley.

5. The elevator apparatus according to 1, wherein a first direction-changing pulley being rotatable around a rotating shaft extending in a vertical direction is disposed in an upper portion inside said hoistway, said first and second main ropes are wound around said first direction-changing pulley and branched off at said first direction-changing pulley, and a second direction-changing pulley being rotatable around a rotating shaft extending in a vertical direction around which said first main rope is wound is disposed between said first direction-changing pulley and said first car return sheave.

6. The elevator apparatus according to 1, wherein said first and second main ropes are composed of a synthetic fiber rope.

7. An elevator apparatus comprising:

a hoistway having a hoistway wall;
a driving machine disposed in an upper portion inside said hoistway, having:

a driving machine body; and
a drive sheave rotated by said driving machine body around

a rotating shaft extending in a vertical direction;
a main rope having a car end portion and a counterweight end portion secured to an upper portion inside said hoistway, an intermediate portion being wound around said drive sheave;
a car having mutually opposite first and second side surfaces, being suspended inside said hoistway by said main rope between said drive sheave and said car end portion so as to be raised and lowered inside said hoistway by said driving machine;
a counterweight disposed between said first side surface and said hoistway wall, being suspended inside said hoistway by said main rope between said drive sheave and said counterweight end portion so as to be raised and lowered inside said hoistway by said driving machine;

a car return sheave disposed in an upper portion inside said hoistway and around which said main rope is wound, for guiding said main rope from said drive sheave to said car; and

a counterweight return sheave disposed in an upper portion inside said hoistway and around which said main rope is wound, for guiding said main rope from said drive sheave to said counterweight,

wherein said driving machine is disposed above a corner portion of a rear portion of said car on a side near said counterweight, and said car and counterweight return sheaves are disposed above a space between said first side surface and said hoistway wall.

8. The elevator apparatus according to 7, wherein said main rope is composed of a synthetic fiber rope.

Claims

1. An elevator apparatus comprising:

a hoistway (31) having a hoistway wall (31a to 31c);

a driving machine (36) disposed in an upper portion inside said hoistway (31), having:

a driving machine body (37); and

a drive sheave (38) rotated by said driving machine body (37) around

a rotating shaft extending in a vertical direction;

a main rope having a car (34) end portion and a counterweight end portion secured to an upper portion inside said hoistway (31), an intermediate portion being wound around said drive sheave (38);

a car (34) having mutually opposite first and second side surfaces (34a, 34b), being suspended inside said hoistway (31) by said main rope (39) between said drive sheave (38) and said car end portion (39a) so as to be raised and lowered inside said hoistway (31) by said driving machine (36);

a counterweight (35) disposed between said first side surface and said hoistway wall, being suspended inside said hoistway (31) by said main rope (39) between said drive sheave (38) and said counterweight end portion so as to be raised and lowered inside said hoistway (31) by said driving machine (36);

a car return sheave (41) disposed in an upper portion inside said hoistway (31) and around which said main rope (39) is wound,

for guiding said main rope (39) from said drive sheave (38) to said car (34); and a counterweight return sheave (42) disposed in an upper portion inside said hoistway (31) and around which said main rope (39) is wound, for guiding said main rope (39) from said drive sheave (38) to said counterweight (35),

wherein said driving machine (36) is disposed above a corner portion of a rear portion of said car (34) on a side near said counterweight (35), and said car and counterweight return sheaves (41) are disposed above a space between said first side surface (34a) and said hoistway wall (31a).

2. The elevator apparatus according to Claim 1, wherein said main rope (39) is composed of a synthetic fiber rope.

FIG. 3

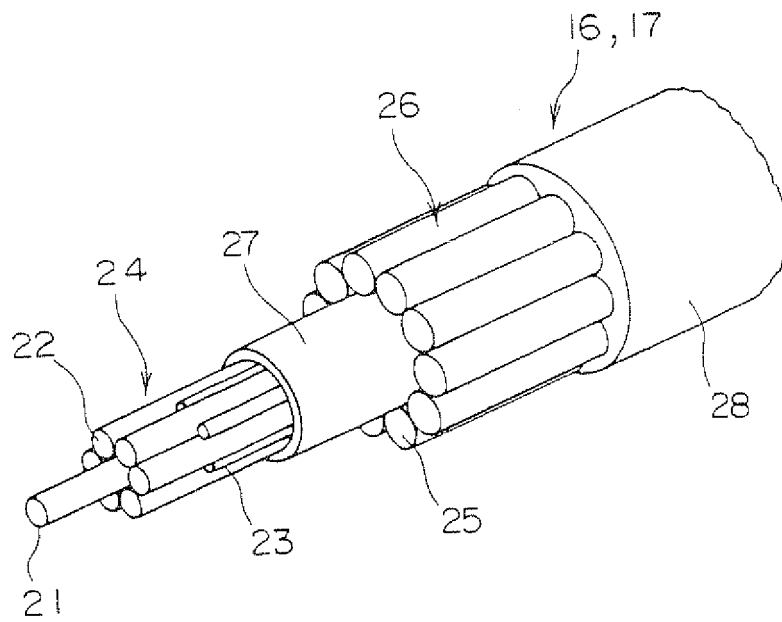

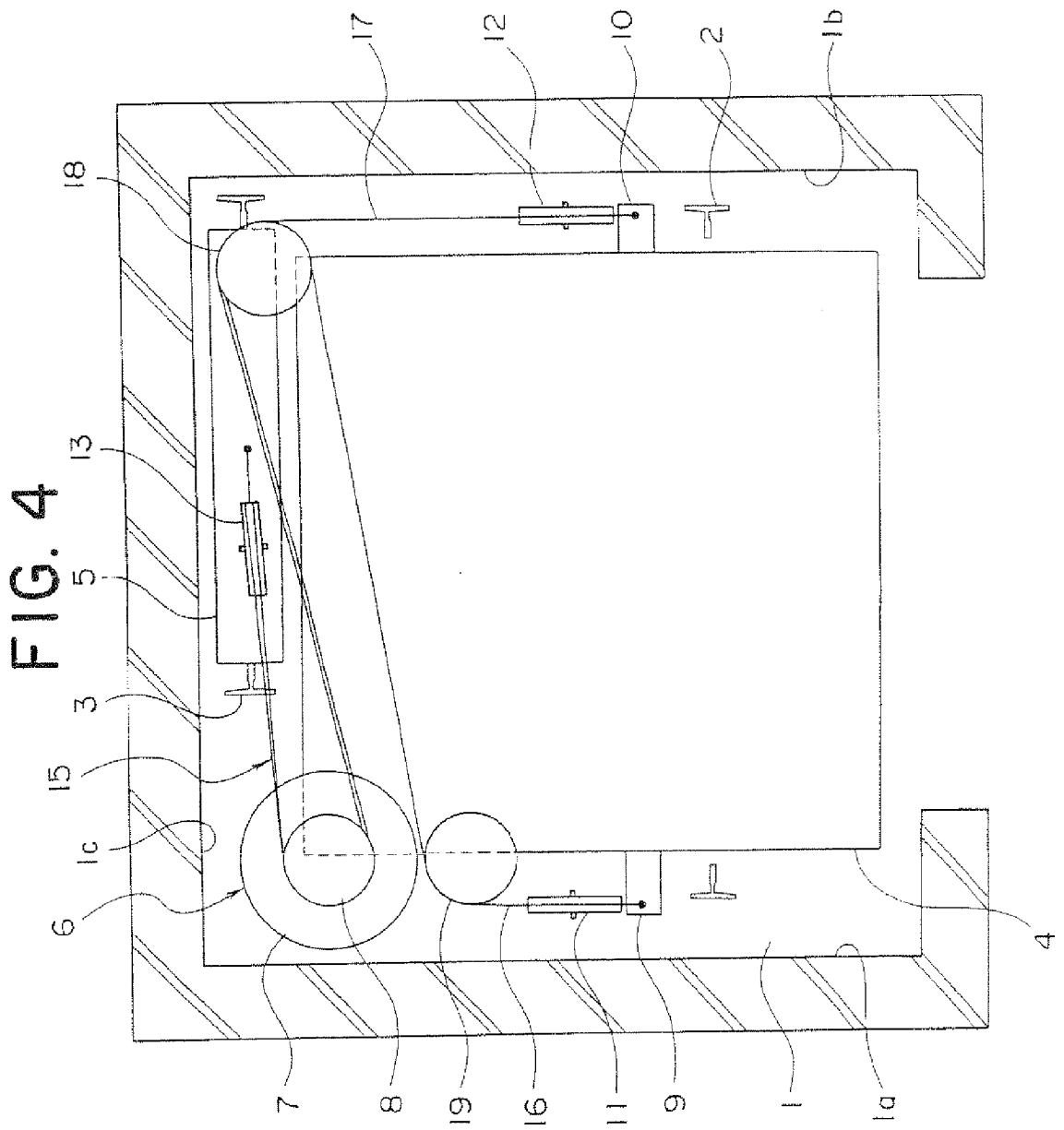

FIG. 5

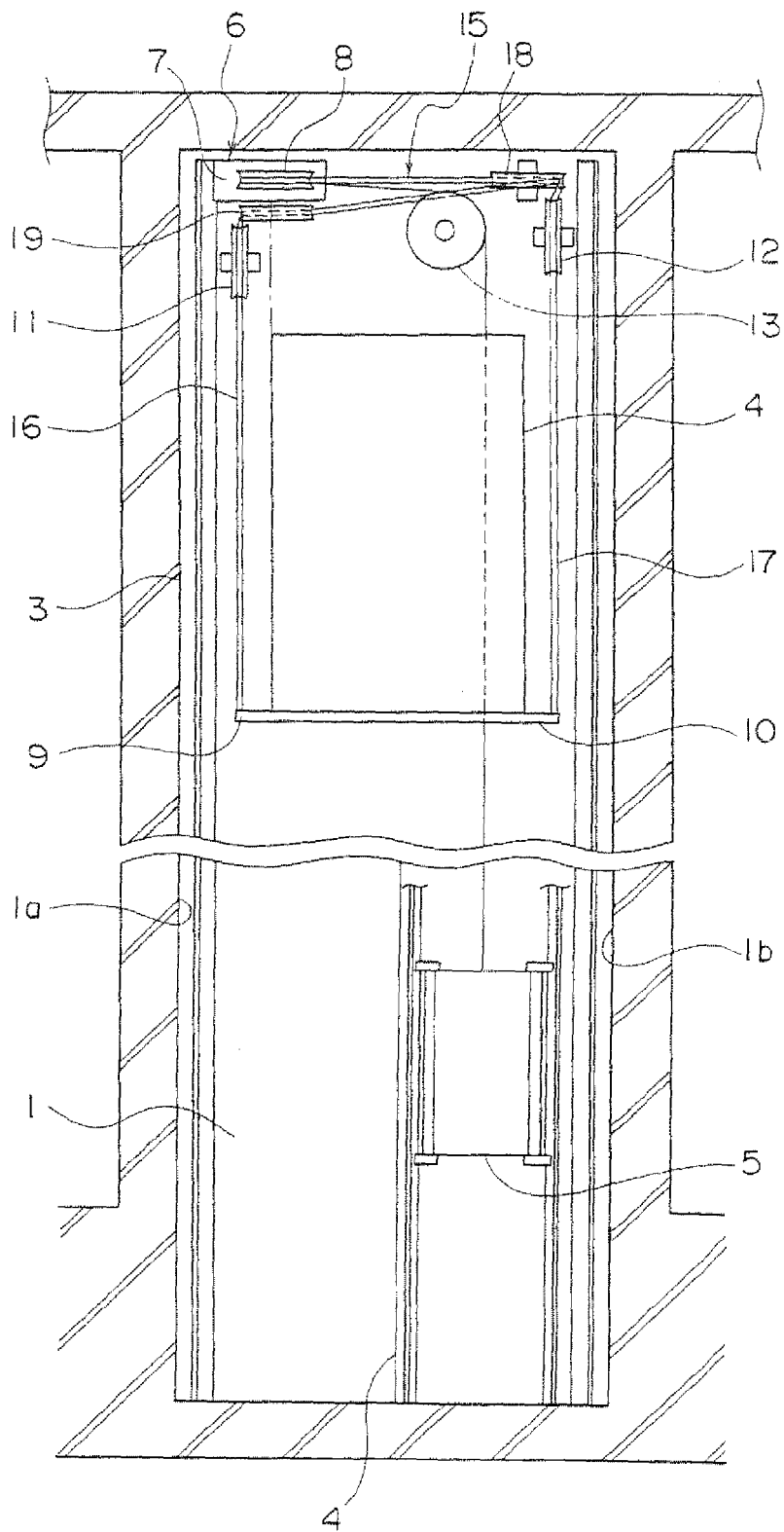

FIG. 6

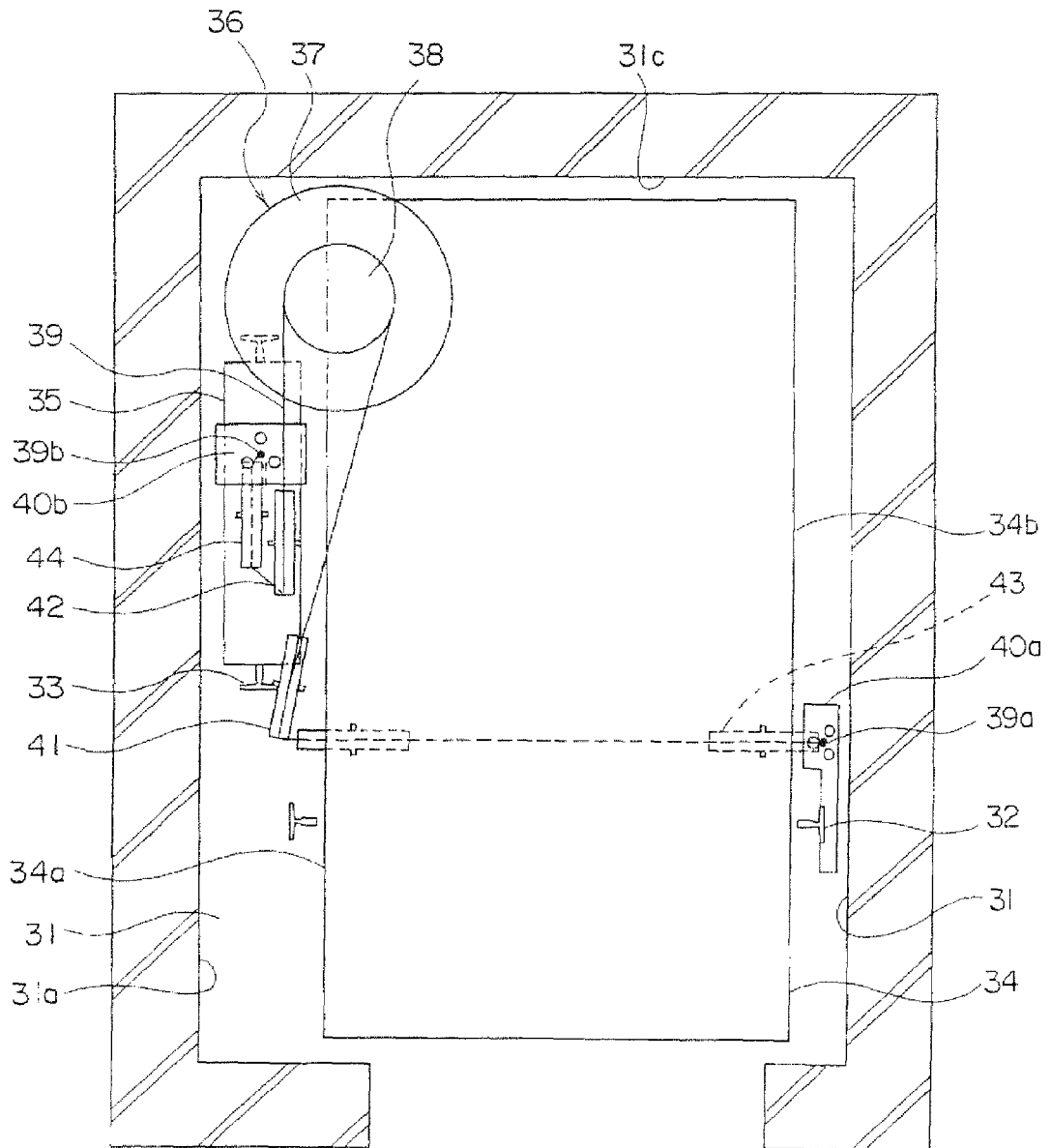
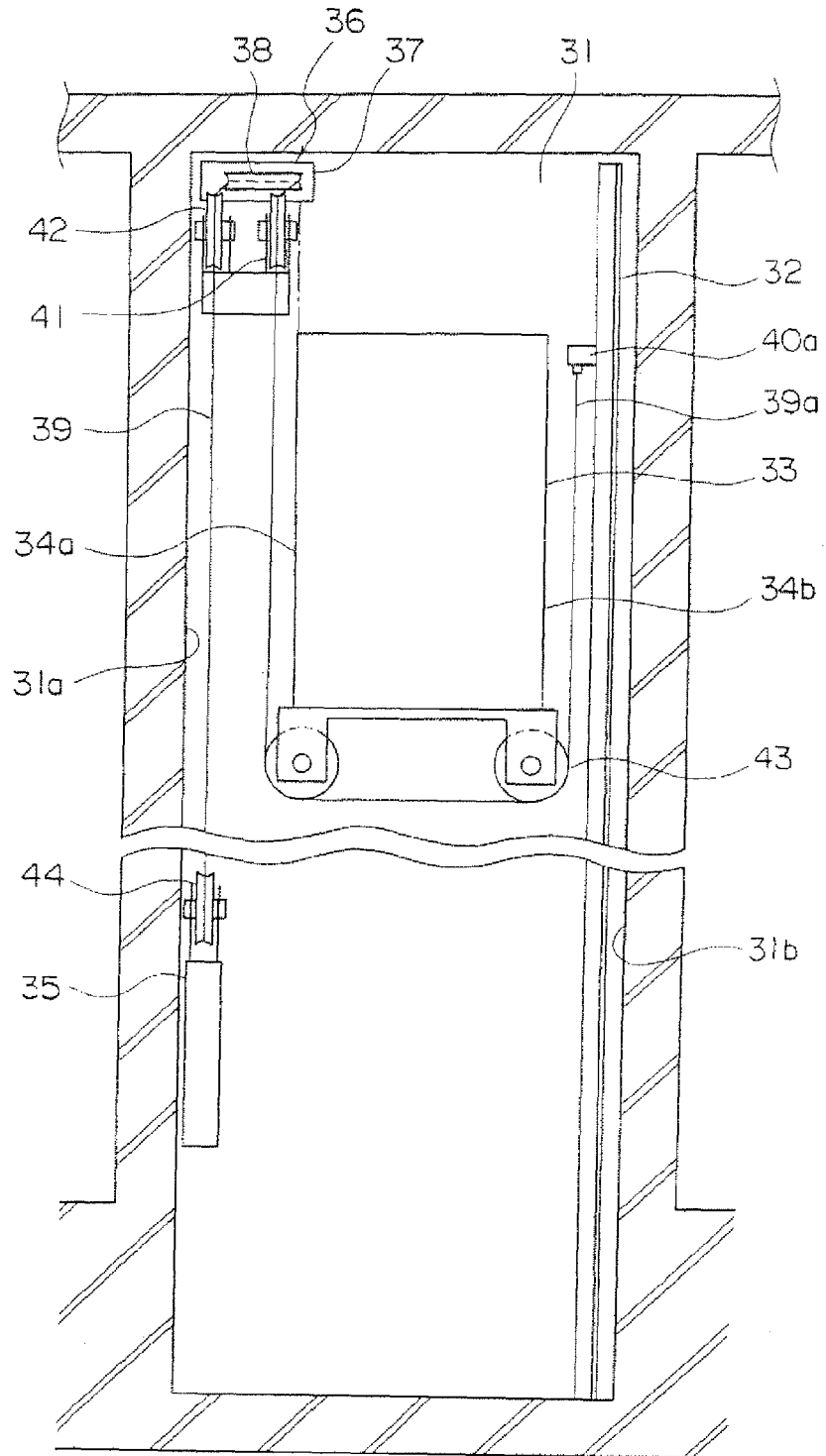

FIG. 7





EUROPEAN SEARCH REPORT

Application Number
EP 09 15 0612

DOCUMENTS CONSIDERED TO BE RELEVANT			
Category	Citation of document with indication, where appropriate, of relevant passages	Relevant to claim	CLASSIFICATION OF THE APPLICATION (IPC)
A	EP 1 018 480 A (MITSUBISHI ELECTRIC CORP [JP]) 12 July 2000 (2000-07-12) * paragraph [0041] - paragraph [0046]; figures 15-17 *	1,2	INV. B66B11/00 B66B11/08
A	EP 0 731 209 A (INVENTIO AG [CH]) 11 September 1996 (1996-09-11) * abstract *	2	
			TECHNICAL FIELDS SEARCHED (IPC)
			B66B
The present search report has been drawn up for all claims			
Place of search The Hague		Date of completion of the search 17 February 2009	Examiner Janssens, Gerd
CATEGORY OF CITED DOCUMENTS X : particularly relevant if taken alone Y : particularly relevant if combined with another document of the same category A : technological background O : non-written disclosure P : intermediate document		T : theory or principle underlying the invention E : earlier patent document, but published on, or after the filing date D : document cited in the application L : document cited for other reasons & : member of the same patent family, corresponding document	

EPO FORM 1503 03 82 (P04G01) 2

**ANNEX TO THE EUROPEAN SEARCH REPORT
ON EUROPEAN PATENT APPLICATION NO.**

EP 09 15 0612

This annex lists the patent family members relating to the patent documents cited in the above-mentioned European search report. The members are as contained in the European Patent Office EDP file on
The European Patent Office is in no way liable for these particulars which are merely given for the purpose of information.

17-02-2009

Patent document cited in search report		Publication date	Patent family member(s)	Publication date
EP 1018480	A	12-07-2000	CN 1260319 A	19-07-2000
			DE 60012588 D1	09-09-2004
			DE 60012588 T2	04-08-2005
			JP 4191331 B2	03-12-2008
			JP 2000255933 A	19-09-2000
			KR 20000052619 A	25-08-2000

EP 0731209	A	11-09-1996	AR 001155 A1	24-09-1997
			AT 181977 T	15-07-1999
			AU 700649 B2	14-01-1999
			AU 4584896 A	19-09-1996
			BR 9600892 A	30-12-1997
			CA 2169431 A1	07-09-1996
			CN 1134484 A	30-10-1996
			CZ 9600649 A3	11-09-1996
			DE 59602355 D1	12-08-1999
			DK 731209 T3	17-01-2000
			ES 2136335 T3	16-11-1999
			HK 1011391 A1	28-04-2000
			HU 9600548 A2	28-05-1997
			JP 3824698 B2	20-09-2006
			JP 8261972 A	11-10-1996
			NO 960880 A	09-09-1996
			NZ 286035 A	24-06-1997
			PL 313088 A1	16-09-1996
			RU 2148117 C1	27-04-2000
TR 960867 A2	21-10-1996			
ZA 9601733 A	10-09-1996			
