

(19)



(11)

EP 2 043 124 A1

(12)

EUROPEAN PATENT APPLICATION

(43) Date of publication:
01.04.2009 Bulletin 2009/14

(51) Int Cl.:
H01H 13/705 (2006.01)

(21) Application number: **07117582.2**

(22) Date of filing: **28.09.2007**

(84) Designated Contracting States:
**AT BE BG CH CY CZ DE DK EE ES FI FR GB GR
 HU IE IS IT LI LT LU LV MC MT NL PL PT RO SE
 SI SK TR**
 Designated Extension States:
AL BA HR MK RS

(74) Representative: **Rickard, David John et al**
Ipulse
26 Mallinson Road
London
SW11 1BP (GB)

(71) Applicant: **Research In Motion Limited**
Waterloo, Ontario N2L 3W8 (CA)

Remarks:
 Amended claims in accordance with Rule 137(2)
 EPC.

(72) Inventor: **Chen, Chao**
Waterloo Ontario N2T 2T8 (CA)

(54) Keypad for a wireless device

(57) A keypad for a wireless device is disclosed. The keypad comprises one or more key stems, each key stem having an upper key stem surface. The keypad also comprises one or more keycaps configured to be mounted over the one or more key stems, each keycap having a

lower keycap surface for bonding to the upper key stem surface of each key stem with adhesive. The upper key stem surface includes at least one depression and at least one groove along a perimeter of the upper key stem surface. The depression and groove can help reduce the risk of adhesive flow to undesirable areas.

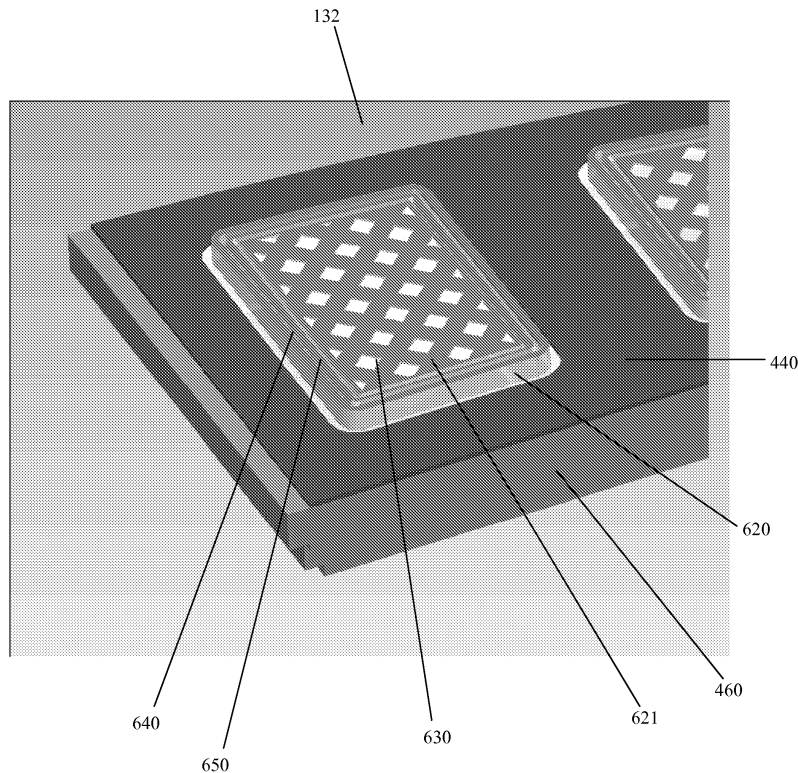

FIG. 4

EP 2 043 124 A1

Description

[0001] This application relates generally to the field of wireless devices, and more specifically, to a keypad for a wireless device.

[0002] Current wireless mobile communication devices include microprocessors, memory, soundcards, speakers, headphones, and run one or more software applications in addition to providing for voice communications. Examples of software applications used in these wireless devices include micro-browsers, address books, email clients, instant messaging ("IM") clients, and wavetable instruments. Additionally, wireless devices have access to a plurality of services via the Internet. A wireless device may, for example, be used to browse web sites on the Internet, to transmit and receive graphics, and to execute streaming audio and/or video applications. Such wireless devices may operate on a cellular network, on a wireless local area network ("WLAN"), or on both of these types of networks.

[0003] One problem with current wireless devices pertains to the performance of the device's keypad. In particular, the keys of the keypad are often stiff, making them difficult for a user to depress to initiate an input or selection. The keypad of a wireless device typically includes the following components: keycaps, clear (or translucent or white in colour) silicon rubber key stems coupled by a clear (or translucent or white in colour) silicon rubber web, clear plastic light guides, an opaque (e.g., black) polycarbonate ("PC") film for light shielding (e.g., located on top of the web), and opaque (e.g., black) plastic elements for light shielding (e.g., located to the sides of the light guides). These components are typically united or bonded together by an adhesive such as glue. In a typical implementation, the keycaps are glued to the key stems, the glue being applied between the flat lower surface of each keycap and the flat upper surface of each key stem. However, excess glue may flow away from the keycap and key stem and contact the PC film. If the glue comes into contact with the PC film, it may cause the PC film to become bonded to the web (that is coupled to the key stems). This may cause the web to stiffen or strengthen. This stiffening of the web is problematic as it can cause stiffening of the keys of the keypad. In fact, it has been estimated that more than 95% of stiff key problems in keypads of wireless devices are caused by excess adhesive flowing from between the keycaps and key stems.

[0004] A need therefore exists for an improved keypad for a wireless device. Accordingly, a solution that addresses, at least in part, the above and other shortcomings is desired.

GENERAL

[0005] In one embodiment that may be provided a keypad for a wireless device, comprising: at least one key stem coupled by a web, the key stem having an upper key stem surface, the web for allowing the key stem to

independently travel when pressure is applied to the upper key stem surface thereof; and, for each key stem, a keycap configured to be mounted over the key stem, the keycap having a lower keycap surface configured to be bonded to the upper key stem surface of the key stem with an adhesive; wherein the upper key stem surface has formed therein a depression and a groove along a perimeter of the upper key stem surface and substantially enclosing the depression. The Keypad may comprise any one or more of the features described herein in combination with one or more other features described herein, or separate from some features notwithstanding that they may be described together or separately.

[0006] In another embodiment there may be provided a wireless device having a keypad as described herein.

BRIEF DESCRIPTION OF THE DRAWINGS

[0007] Features and advantages of the embodiments of the present application will become apparent from the following detailed description, taken in combination with the appended drawings, in which:

[0008] FIG. 1 is a front view illustrating an example of a wireless device in accordance with an embodiment of the application;

[0009] FIG. 2 is a block diagram illustrating the wireless device of FIG. 1;

[0010] FIG. 3 is a block diagram illustrating a memory of the wireless device of FIG. 1;

[0011] FIG. 4 is a partial perspective view illustrating a keypad for a wireless device in accordance with an embodiment of the application with the keycaps removed; and,

[0012] FIG. 5 is a partial perspective cross section view illustrating the keypad of FIG. 4 in accordance with an embodiment of the application with the keycaps in place.

[0013] It will be noted that throughout the appended drawings, like features are identified by like reference numerals.

DESCRIPTION OF PREFERRED EMBODIMENTS

[0014] In the following description, details are set forth to provide an understanding of the application. In some instances, certain software, circuits, structures and techniques have not been described or shown in detail in order not to obscure the application.

[0015] FIG. 1 is a front view illustrating an example of a wireless device **100** in accordance with an embodiment of the application. The wireless device **100** includes a case **150**, a liquid crystal display ("LCD") **122**, a graphical user interface ("GUI") **180** displayed on the LCD **122**, a lens **105** mounted over the LCD **122** for protection thereof, a speaker **134**, a keypad (or keyboard) **132**, a thumbwheel (or trackwheel) **110**, various select buttons **120**, and various inputs/outputs (e.g., power connector jack, data interface ports, headphones jack, etc.) **160**. Internally, the wireless device **100** typically includes one or

more circuit boards (not shown in FIG. 1), a CPU or microprocessor **138**, memory **124**, **126**, **200**, a battery **156**, an antenna (not shown), etc., which are operatively coupled to the various inputs/outputs **160**, the keypad **132**, the display screen **122**, the speaker **134**, etc., as will be described below.

[0016] FIG. 2 is a block diagram illustrating the wireless device **100** of FIG. 1. The wireless device **100** may operate over a wireless network **220**. The wireless network **220** may include antenna, base stations, access points, transceivers, supporting radio equipment, etc., as known to those of ordinary skill in the art, for supporting wireless communications between the wireless device **100** and other devices (not shown). The wireless network **220** may be coupled to a wireless network gateway (not shown) and to a local area network (not shown) to which the other devices (e.g., data processing systems, computers, etc.) may be coupled.

[0017] The wireless device **100** may be a two-way communication device having at least voice and advanced data communication capabilities, including the capability to communicate with other devices. Depending on the functionality provided by the device **100**, it may be referred to as a data messaging device, a two-way pager, a cellular telephone with data messaging capabilities, a wireless Internet appliance, a data communication device (with or without telephony capabilities), a Wi-Fi device, a WLAN device, a dual-mode (i.e., Wi-Fi and cellular) device, or a portable audio device. The device **100** may communicate with any one of a plurality of transceiver stations (not shown) within its geographic coverage area.

[0018] The wireless device **100** has a communication subsystem **111**, which includes a RF receiver, a RF transmitter, and associated components, such as one or more antenna elements (e.g., embedded or internal), local oscillators ("LOs"), and a processing module such as a digital signal processor ("DSP") (all not shown). As will be apparent to those skilled in the field of communications, the particular design of the communication subsystem **111** depends on the communication network **220** in which the device **100** is intended to operate.

[0019] The device **100** may be capable of cellular network access and hence the device **100** may have a subscriber identity module (or "SIM" card) **162** for inserting into a SIM interface ("IF") **164** in order to operate on the cellular network (e.g., a global system for mobile communication ("GSM") network).

[0020] The device **100** may be a battery-powered device and so it may also include a battery IF **154** for receiving one or more rechargeable batteries **156**. The battery (or batteries) **156** provides electrical power to most if not all electrical circuitry in the device **100**, and the battery IF **154** provides for a mechanical and electrical connection for it. The battery IF **154** is coupled to a regulator (not shown) which provides regulated power to the circuitry of the device **100**.

[0021] The wireless device **100** includes a microproc-

essor **138** which controls overall operation of the device **100**. Communication functions, including at least data and voice communications, are performed through the communication subsystem **111**. The microprocessor **138** also interacts with additional device subsystems such as the display **122**, a flash memory **124** or other persistent store, a random access memory ("RAM") **126**, auxiliary input/output ("I/O") subsystems **128**, a serial port (e.g., a universal serial bus ("USB") port) **131**, the keypad **132**, the clickable thumbwheel **110**, the speaker **134**, a microphone **136**, a short-range communications subsystem **141**, and other device subsystems **142**. Some of the subsystems shown in FIG. 2 perform communication-related functions, whereas other subsystems may provide "resident" or on-device functions. Some subsystems, such as the keypad **132** and display **122**, for example, may be used for both communication-related functions, such as entering a text message for transmission over a communication network, and device-resident functions such as a calculator or task list. Operating system software modules (i.e., **202** in FIG. 3) used by the microprocessor **138** may be stored in a persistent store such as the flash memory **124**, which may alternatively be a read-only memory ("ROM") or similar storage element (not shown). Those skilled in the art will appreciate that the operating system, specific device applications, or parts thereof, may be temporarily loaded into a volatile store such as RAM **126**.

[0022] The microprocessor **138**, in addition to its operating system functions, preferably enables execution of software applications on the device **100**. A predetermined set of applications which control basic device operations, including at least data and voice communication applications, will normally be installed on the device **100** during its manufacture. A preferred application that may be loaded onto the device **100** may be a personal information manager ("PIM") application having the ability to organize and manage data items relating to the user such as, but not limited to, instant messaging ("IM"), email, calendar events, voice mails, appointments, and task items. Naturally, one or more memory stores are available on the device **100** and SIM **162** to facilitate storage of PIM data items and other information.

[0023] The PIM application preferably has the ability to send and receive data items via the wireless network **220**. In a preferred embodiment, PIM data items are seamlessly integrated, synchronized, and updated via the wireless network **220**, with the wireless device user's corresponding data items stored and/or associated with a host computer system (not shown) thereby creating a mirrored host computer on the device **100** with respect to such items. This is especially advantageous where the host computer system is the wireless device user's office or home computer system. Additional applications may also be loaded onto the device **100** through the network **220**, the auxiliary I/O subsystem **128**, the serial port **131**, the short-range communications subsystem **141**, or other device subsystems **142**, and installed by a user in

RAM **126** or non-volatile flash memory **124** for execution by the microprocessor **138**. Such flexibility in application installation increases the functionality of the device **100** and may provide enhanced on-device functions, communication-related functions, or both. For example, secure communication applications may enable electronic commerce functions and other such financial transactions to be performed using the wireless device **100**.

[0024] In a data communication mode, a received signal such as a text message, an email message, or web page download will be processed by the communication subsystem **111** and input to the microprocessor **138**. The microprocessor **138** will preferably further process the signal for output to the display **122** and/or to the auxiliary I/O device **128**. A user of the wireless device **100** may also compose data items, such as email messages, for example, using the keypad **132** in conjunction with the display **122**, and possibly the auxiliary I/O device **128**. The keypad **132** may be, but need not be, a complete alphanumeric keyboard and/or a telephone-type keypad. These composed items may be transmitted over a communication network **220** through the communication subsystem **111** or the short range communication subsystem **141**.

[0025] For voice communications, the overall operation of the wireless device **100** is substantially similar, except that the received signals would be output to the speaker **134** and signals for transmission would be generated by the microphone **136**. Alternative voice or audio I/O subsystems, such as a voice message recording subsystem, may also be implemented on the device **100**. Although voice or audio signal output is preferably accomplished primarily through the speaker **134**, the display **122** may also be used to provide, for example, an indication of the identity of a calling party, duration of a voice call, or other voice call related information.

[0026] The serial port **131** shown in FIG. 2 is normally implemented in a personal digital assistant ("PDA") type communication device for which synchronization with a user's desktop computer is a desirable, albeit optional, component. The serial port **131** enables a user to set preferences through an external device or software application and extends the capabilities of the device **100** by providing for information or software downloads to the device **100** other than through a wireless communication network **220**. The alternate download path may, for example, be used to load an encryption key onto the device **100** through a direct and thus reliable and trusted connection to thereby provide secure device communication.

[0027] The short-range communications subsystem **141** shown in FIG. 2 is an additional optional component which provides for communication between the device **100** and different systems or devices, which need not necessarily be similar devices. For example, the short-range communications subsystem **141** may include an infrared device and associated circuits and components, or a Bluetooth™ communication module, to provide for communication with similarly-enabled systems and de-

vices. (Bluetooth™ is a registered trademark of Bluetooth SIG, Inc.)

[0028] FIG. 3 is a block diagram illustrating a memory **200** of the wireless device **100** of FIG. 1. The microprocessor **138** is coupled to the memory **200**. The memory **200** has various hardware and software components for storing information (e.g., instructions, data, database tables, test parameters, etc.) for enabling operation of the device **100** and may include flash memory **124**, RAM **126**, ROM (not shown), disk drives (not shown), etc. In general, the memory **200** may include a variety of storage devices typically arranged in a hierarchy of storage as understood to those skilled in the art.

[0029] According to one embodiment, the wireless device **100** may be a multi-tasking wireless communications device configured for sending and receiving data items and for making and receiving voice calls. In addition, the microprocessor **138** of the wireless device **100** is typically coupled to one or more devices or subsystems (e.g., **110**, **120**, **132**) for receiving user commands or queries and for displaying the results of these commands or queries to the user on the display **122**. To provide a user-friendly environment to control the operation of the device **100**, operating system ("O/S") software modules **202** resident on the device **100** provide a basic set of operations for supporting various applications typically operable through the GUI **180** and supporting GUI software modules **204**. For example, the O/S **202** provides basic input/output system features to obtain input from the auxiliary I/O **128**, the keypad **132**, the clickable thumbwheel **110**, and the like, and for facilitating output to the user through the display **122**, the speaker **134**, etc. Though not shown, one or more applications for managing communications or for providing personal digital assistant like functions may also be included. According to one embodiment, the wireless device **100** is provided with hardware and/or software modules **206** for facilitating and implementing various additional functions.

[0030] A user may interact with the wireless device **100** and its various software modules **202**, **204**, **206**, using the GUI **180**. GUIs are supported by common operating systems and provide a display format which enables a user to choose commands, execute application programs, manage computer files, and perform other functions by selecting pictorial representations known as icons, or items from a menu through use of an input or pointing device such as a thumbwheel **110** and keypad **132**. In general, a GUI is used to convey information to and receive commands from users and generally includes a variety of GUI objects or controls, including icons, toolbars, drop-down menus, pop-up menus, text, dialog boxes, buttons, and the like.

[0031] A user typically interacts with a GUI **180** presented on a display **122** by using an input or pointing device (e.g., a thumbwheel **110**, a keypad **132**, etc.) to position a pointer or cursor over an object (i.e., "pointing" at the object) and by "clicking" on the object such as by depressing the thumbwheel **110** or by depressing a but-

ton on the keypad **132**. This is often referred to as a point-and-click operation or a selection operation. Typically, the object may be hi-lighted (e.g., shaded) when it is pointed at. As will be discussed in more detail below, stiffening of the keys of the keypad **132** can make the keys difficult for a user to depress to initiate an input or selection, thereby affecting the user's interaction with GUI **180**.

[0032] Typically, a GUI based system presents application, system status, and other information to the user in "windows" appearing on the display **122**. A window is a more or less rectangular area within the display **122** in which a user may view an application or a document. Such a window may be open, closed, displayed full screen, reduced to an icon, increased or reduced in size, or moved to different areas of the display **122**. Multiple windows may be displayed simultaneously, such as: windows included within other windows, windows overlapping other windows, or windows tiled within the display area.

[0033] FIG. 4 is a partial perspective view illustrating a keypad **132** for a wireless device **100** in accordance with an embodiment of the application. In FIG 4 the keycaps are removed. FIG. 5 is a partial perspective cross section view illustrating the keypad **132** of FIG. 4 including the keycaps in accordance with an embodiment of the application. The keypad **132** of a wireless device **100** typically includes the following components: keycaps **410**, clear (or translucent or white in colour) silicon rubber key stems **620** coupled by a clear (or translucent or white in colour) silicon rubber web **430**, clear plastic light guides **480**, a substantially opaque (e.g., black) polycarbonate ("PC") film **440** for light shielding proximate to the web **430** (e.g., located on top of the web **430**), and opaque (e.g., black) plastic elements (e.g., frame, shield, etc.) **460** for light shielding (e.g., located to the sides of the light guides **480**). Some of these components may be united or bonded together by an adhesive. The adhesive may be any form of glue, paste, resin, cement or any other substance that can bind one element to another. Many types of adhesive can exist in a liquid or semi-liquid state and, when in that state, can flow. Some types of adhesive can also assume a substantially solid form in which the adhesive does not substantially flow. Examples of adhesives that may be used in the implementations described below include instant glue and ultraviolet light-cured glue.

[0034] In a typical implementation, the keycaps **410** are shaped or otherwise configured to be placed in proximity to and mounted over key stems **620**, and to be bonded to key stems **620**. Each lower keycap surface **411** may be bonded to a respective upper surface **621** of a key stem **620** with an adhesive such as glue, the glue being applied in a liquid or semi-liquid state between the lower surface **411** of each keycap **410** and the upper surface **621** of each key stem **620**. As it becomes more solid, the glue bonds a lower keycap surface **411** to a respective upper surface **621** of a key stem **620**. Because

the glue is delivered in a state in which it can flow, excess glue may flow away from the keycap **410** and key stem **620** and contact the surrounding PC film **440**. If the glue comes into contact with the PC film **440**, it may cause the PC film **440** to become bonded to the web **430** (that is coupled to the key stems **620**). This may cause the web **430** to stiffen or strengthen. This stiffening of the web **430** is problematic as it can cause stiffening of the keys of the keypad **132**.

[0035] The present application provides a keypad **132** that includes features that reduce adhesive overflow onto the web **430** and hence reduce the occurrence of stiff keypad keys.

[0036] As depicted in FIG. 4, an upper surface **621** of key stem **620** is bonded to lower surface **411** of keycap **410**. As depicted in FIG. 5, the upper surface **621** of each key stem **620** has features that reduce adhesive overflow. In the exemplary embodiment depicted in FIG. 5, shallow (e.g., approximately 0.05 mm deep) depressions **630** are included in the upper surface **621** of each key stem **620**. The depressions **630**, which are depicted in FIG. 5 as square, but which can be any shape, act to slow down the flow of adhesive (i.e., make it more difficult for the adhesive to move). The depressions **630** thereby reduce adhesive overflow, including overflow that may result in the event that excess adhesive is applied.

[0037] FIG. 5 also depicts two grooves (e.g., approximately 0.15 mm deep) **640**, **650** that are included in the upper surface **621** of each key stem **620** along the edges (i.e., the perimeter) of the key stem **620**. The grooves **640**, **650** guide the flow of any adhesive that is applied to the upper surface **621**. In the event that excess adhesive is applied, the excess adhesive flows along the grooves **640**, **650** rather than flowing to or over the edge of the upper key stem surface **621** where it may contact the PC film **440** or any other component where adhesive does not belong. Adhesive may also tend to enter the grooves **640**, **650** rather than flow to undesirable areas, thereby reducing the chance that adhesive will come into contact with the PC film **440** or any other component where adhesive does not belong.

[0038] As depicted in FIG. 5, the grooves **640**, **650** are substantially outside the depressions **630**. In other words, the grooves **640**, **650** are disposed between the edge of the upper key stem surface **621** and the depressions **630**, and the depressions **630** are generally not disposed between the edge of the upper key stem surface **621** and any of the grooves **640**, **650**. In the example implementation of FIG. 5, the grooves **640**, **650** completely surround or enclose the depressions **630**, although this application includes embodiments in which a groove does not form a closed curve, and thus a depression is substantially enclosed by a groove, although not completely enclosed.

[0039] According to one embodiment, the lower surface **622** of each key stem **620** is used to contact a signal generator (not shown) for transmitting a signal to the microprocessor **138** for indicating that the corresponding

key has been pressed by a user. According to one embodiment, the signal generator includes a dome membrane (not shown). The dome membrane may be, for example, a poly dome membrane or a metal dome membrane.

[0040] According to one embodiment, the web **430** is flexible allowing for travel of a key stem **620** when the keycap **410** bonded to the key stem **620** is pressed by a user (i.e., when pressure is applied to the upper key stem surface **621**). According to another embodiment, the key stems **620** and the web **430** are formed in one piece, and are made from the same materials, such as silicon (or silicone) rubber.

[0041] According to one embodiment, the keypad **132** includes a backlight (e.g., a light emitting diode ("LED")) (not shown) mounted in a pocket **470** formed in a light guide **480** located below the PC film **440** and adjacent to the key stem **620** for emitting light through the upper key stem surface **621** and keycap **410**. In this embodiment, the PC film **440** prevents light from being transmitted through the web **430** and/or other components between key stems **620**. In one embodiment, the light guides **480** and the opaque shielding elements **460** can be bonded together with adhesive, although this adhesive is not necessarily the same as the adhesive that bonds an upper key stem surface **621** to a keycap **410**.

[0042] According to another embodiment, rather than the clear light guides **480** and the opaque shielding elements **460** being bonded together with adhesive as described above, the shielding elements **460** may be formed over the light guides **480** in a double shot injection molding process. In particular, a first shot injection molding step may be used to form the clear light guides **480**. This may be followed by a second shot injection molding step which molds the opaque shielding elements **460** over the clear light guides **480**.

[0043] According to one embodiment, the depressions **630** added to the upper surface **621** of each key stem **620** may be one or more of a number of shapes (e.g., square, rectangular, triangular, round, polygonal, etc.). The depressions **630** need not be uniform in size or in shape, although the depressions **630** may be uniform in size, uniform in shape, or both. Although FIG. 5 depicts a grid made from a plurality of square depressions **630**, according to one embodiment, the depressions **630** may be arranged in one or more of a number of patterns (e.g., in rows, in arcs, in circles, randomly, etc.). Further, FIG. 5 depicts the grid of square depressions **630** at an angle with respect to the perimeter of the upper key stem surface **621**, but the application encompasses embodiments in which a grid of depressions aligns with the perimeter. Moreover, although embodiments have been described having a plurality of depressions **630**, the application encompasses embodiments having a single depression as well.

[0044] According to one embodiment, the grooves **640, 650** present substantially straight lines that are substantially a uniform distance from the edge along the pe-

rimeter of the upper surface **621**. Additional embodiments may include more or fewer than two grooves, and the grooves need not include straight lines or be any uniform distance from the edge of the upper surface **621**.

5 The grooves **640, 650** may be, but need not be, parallel to one another. One groove may completely or substantially enclose another, as depicted in FIG. 5, but the application includes embodiments in which the grooves cross one another. Further, an individual groove need not form a closed loop, and grooves along the perimeter of the upper surface **621** may comprise one or more un-

10 connected segments.

[0045] The application may provide one or more advantages. First, the depressions **630** added to each upper key stem surface **621** reduce the flow rate of adhesive which reduces overflow of excess adhesive onto the PC film **440**, hence reducing the occurrence of stiff keypad keys. Second, the grooves **640, 650** absorb excess adhesive, hence further reducing overflow of excess adhesive onto the PC film **440** and hence further reducing the occurrence of stiff keypad keys. Third, the presence of depressions **630** or grooves **640, 650** does not substantially interfere with bonding an upper surface **621** of the key stem **620** to a lower surface **411** of the keycap **410**.

20 **[0046]** The embodiments of the application described above are intended to be exemplary only. Those skilled in this art will understand that various modifications of detail may be made to these embodiments, all of which come within the scope of the application.

30

Claims

1. A keypad for a wireless device, comprising:

35

at least one key stem coupled by a web, the key stem having an upper key stem surface, the web for allowing the key stem to independently travel when pressure is applied to the upper key stem surface thereof; and, for each key stem, a keycap configured to be mounted over the key stem, the keycap having a lower keycap surface configured to be bonded to the upper key stem surface of the key stem with an adhesive;

45

wherein the upper key stem surface has formed therein a depression and a groove along a perimeter of the upper key stem surface and substantially enclosing the depression.

50

2. The keypad of claim 1 and further comprising a substantially opaque film proximate to the web.

55

3. The keypad of claim 2 wherein the film is a polycarbonate film.

4. The keypad of any one of claims 1 to 3 wherein the depression is a square depression.

- 5. The keypad of claim 4 wherein the square depression is a grid of square depressions.
- 6. The keypad of claim 5 wherein the grid of square depressions is at an angle with respect to the perimeter of the upper key stem surface. 5
- 7. The keypad of any preceding claim wherein the groove completely encloses the depression. 10
- 8. The keypad of any preceding claim, wherein the groove is a first groove, the keypad further comprising a second groove along the perimeter of the upper key stem surface, the second groove substantially enclosing the first groove. 15
- 9. The keypad of any preceding claim wherein the key stem and the web are formed in one piece.
- 10. The keypad of claim 9 wherein the key stem and the web are made from silicon rubber. 20
- 11. The keypad of claim 10 wherein the silicon rubber key stem and the silicon rubber web are translucent. 25
- 12. The keypad of any preceding claim wherein the keycap is bonded to the key stem with an adhesive which is one of instant glue and ultraviolet light-cured glue.
- 13. The keypad of any preceding claim wherein the depression is approximately 0.05 millimeters deep. 30
- 14. The keypad of any of claims 1 to 12 wherein the groove is approximately 0.15 millimeters deep. 35
- 15. The keypad of any preceding claim comprising a plurality of key stems coupled to each other by the web.
- 16. A wireless device having a keypad as claimed in any preceding claim. 40

Amended claims in accordance with Rule 137(2) EPC.

- 1. A keypad for a wireless device, comprising:

at least one key stem coupled by a web, the key stem having an upper key stem surface, the web for allowing the key stem to independently travel when pressure is applied to the upper key stem surface thereof; 50

a film applied over an upper surface of the web and below the upper key stem surface; and,

for each key stem, a keycap configured to be mounted over the key stem, the keycap having a lower keycap surface configured to be bonded to the upper key stem surface of the key stem 55

with an adhesive;

wherein the upper key stem surface has formed therein a depression for reducing potential overflow of the adhesive onto the film by reducing a flow rate of the adhesive and a groove along a perimeter of the upper key stem surface and substantially enclosing the depression into which adhesive may flow whereby to further reduce potential overflow of the adhesive onto the film.

2. The keypad of claim 1 wherein the film is a substantially opaque film to reduce light transmission through the web.

3. The keypad of claim 2 wherein the film is a polycarbonate film.

4. The keypad of any one of claims 1 to 3 wherein the depression is a square depression.

5. The keypad of claim 4 wherein the square depression is a grid of square depressions.

6. The keypad of claim 5 wherein the grid of square depressions is at an angle with respect to the perimeter of the upper key stem surface.

7. The keypad of any preceding claim wherein the groove completely encloses the depression.

8. The keypad of any preceding claim, wherein the groove is a first groove, the keypad further comprising a second groove along the perimeter of the upper key stem surface, the second groove substantially enclosing the first groove.

9. The keypad of any preceding claim wherein the key stem and the web are formed in one piece.

10. The keypad of claim 9 wherein the key stem and the web are made from silicon rubber.

11. The keypad of claim 10 wherein the silicon rubber key stem and the silicon rubber web are translucent.

12. The keypad of any preceding claim wherein the keycap is bonded to the key stem with an adhesive which is one of instant glue and ultraviolet light-cured glue.

13. The keypad of any preceding claim wherein the depression is approximately 0.05 millimeters deep.

14. The keypad of any of claims 1 to 12 wherein the groove is approximately 0.15 millimeters deep.

15. The keypad of any preceding claim comprising

a plurality of keys stems coupled to each other by the web.

16. A wireless device having a keypad as claimed in any preceding claim.

5

10

15

20

25

30

35

40

45

50

55

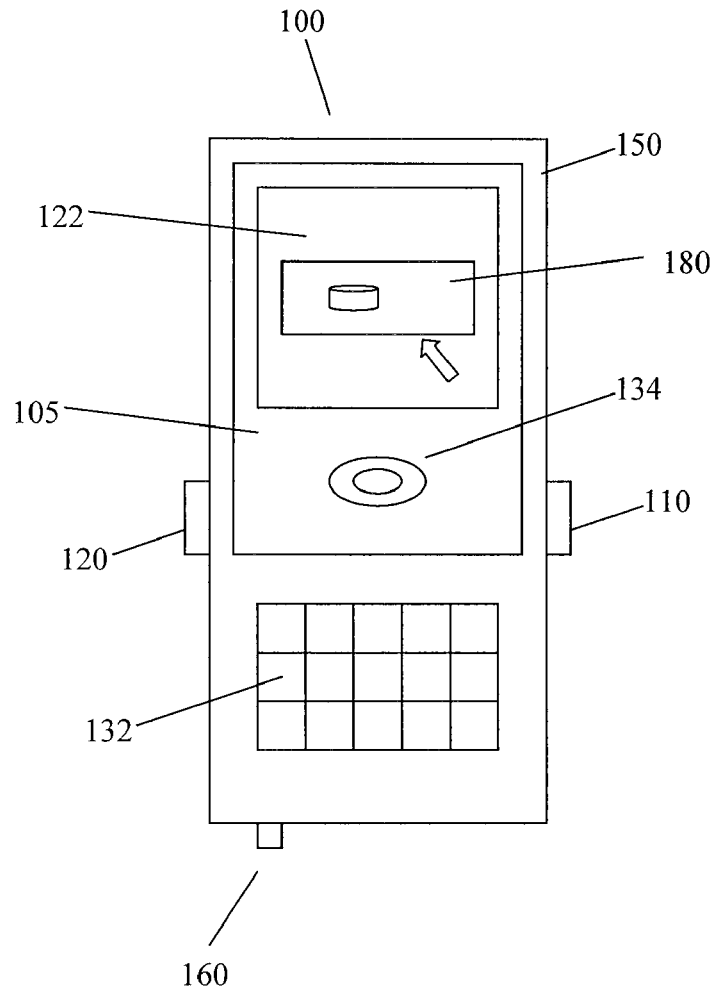

FIG. 1

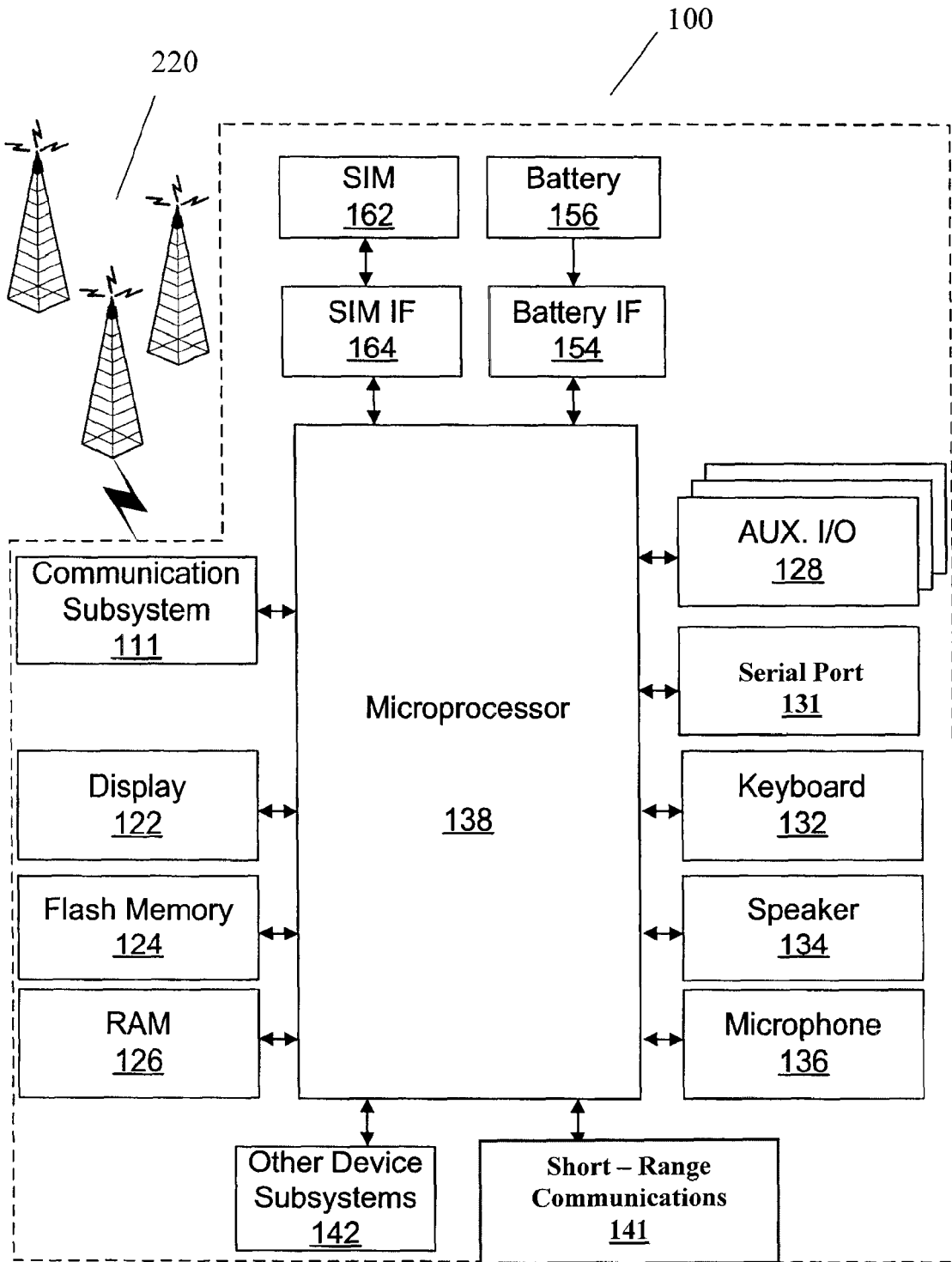

FIG. 2

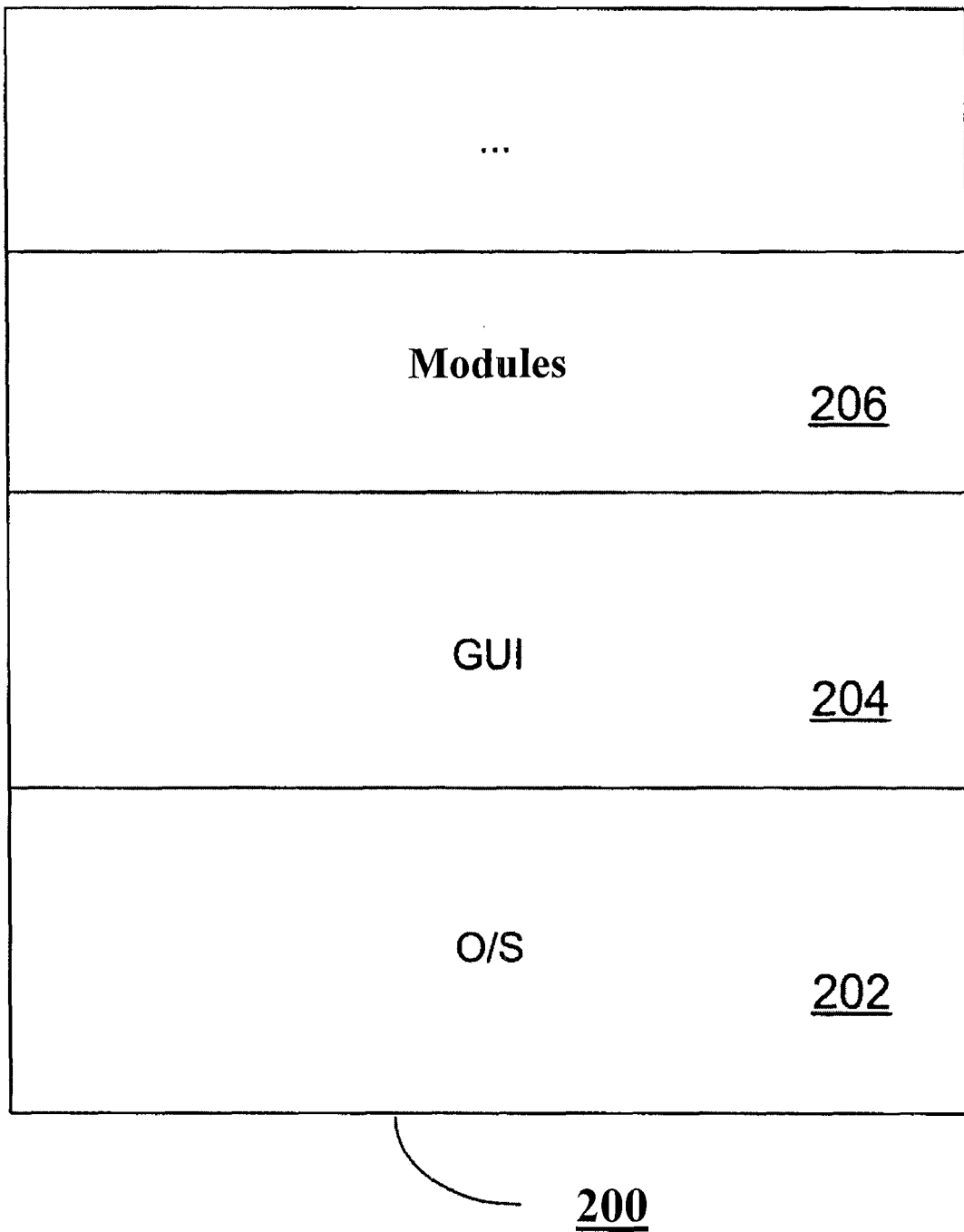

FIG. 3

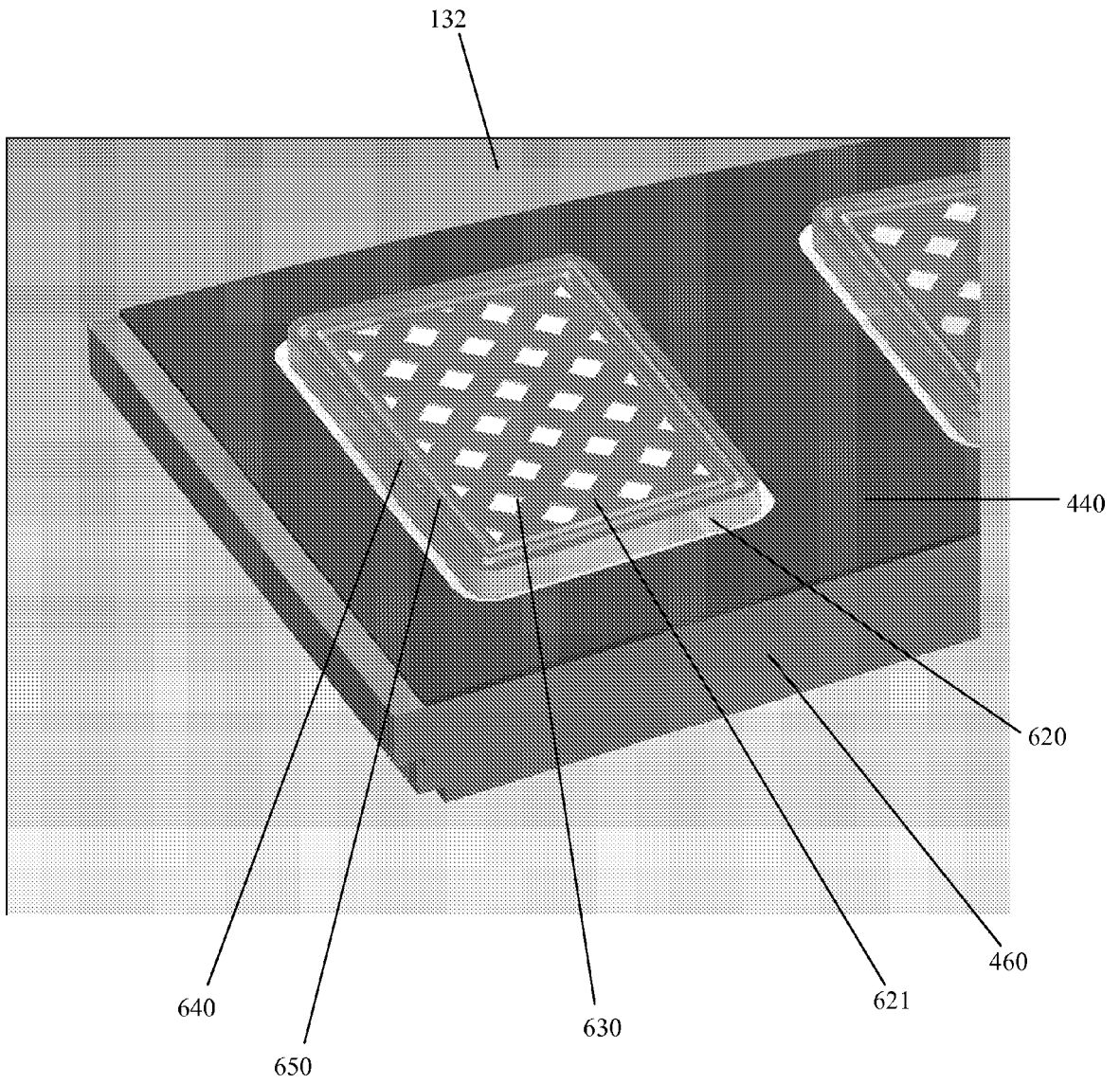

FIG. 4

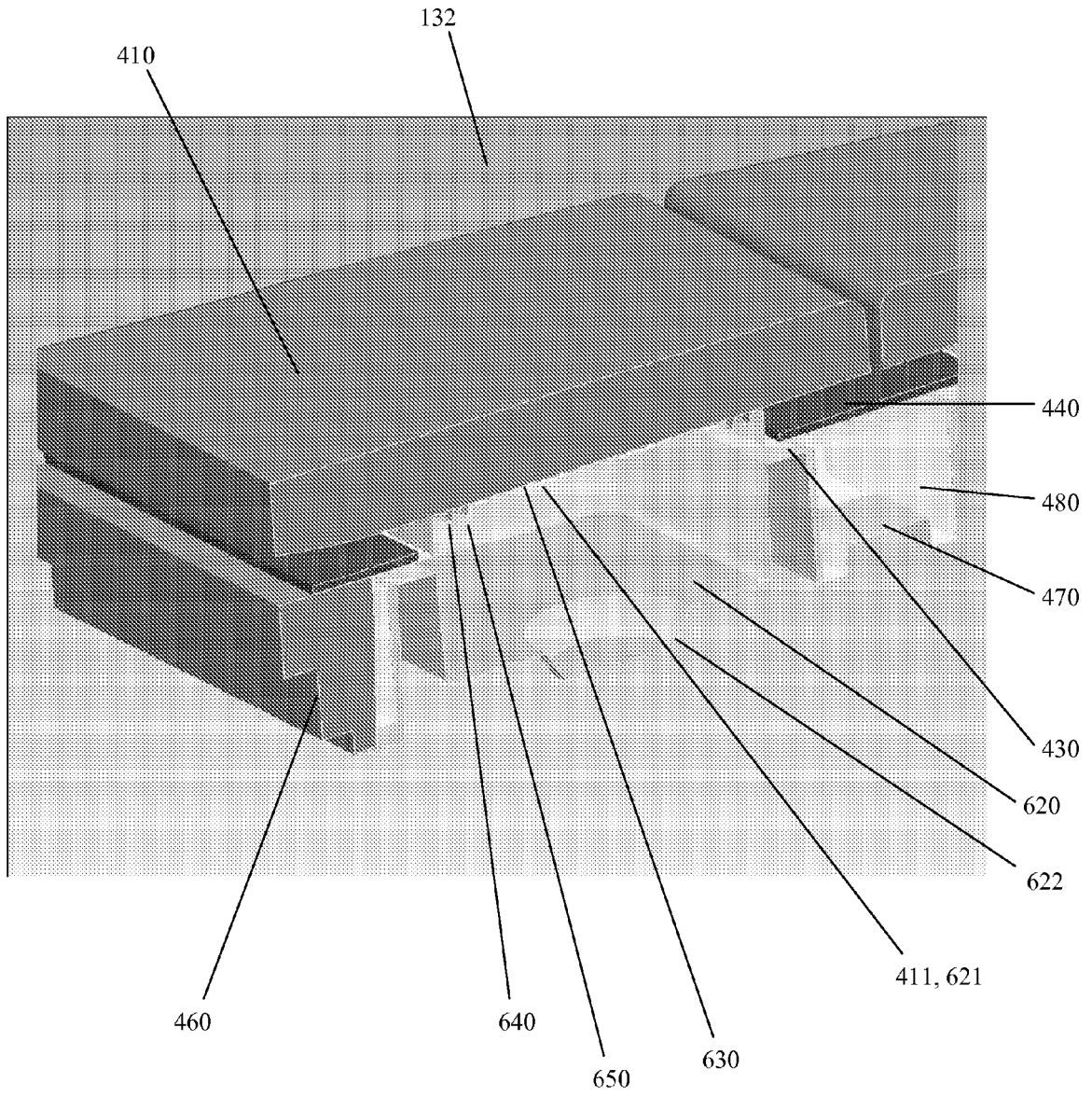

FIG. 5



DOCUMENTS CONSIDERED TO BE RELEVANT			
Category	Citation of document with indication, where appropriate, of relevant passages	Relevant to claim	CLASSIFICATION OF THE APPLICATION (IPC)
Y	US 2002/027065 A1 (KENMOCHI YOSHIO [JP]) 7 March 2002 (2002-03-07) * paragraph [0043] - paragraph [0049]; figures 1-3 *	1-16	INV. H01H13/705
Y	----- US 7 102 093 B1 (CHIU CHIN-TE [TW]) 5 September 2006 (2006-09-05) * column 2, line 39 - column 3, line 26; figures 3,4 *	1-16	
Y	----- JP 2005 050709 A (POLYMATECH CO LTD) 24 February 2005 (2005-02-24) * abstract *	1	
Y	----- JP 2003 297181 A (SUNARROW LTD) 17 October 2003 (2003-10-17) * abstract *	1	
A	----- EP 1 137 028 A (ALPS ELECTRIC CO LTD [JP]) 26 September 2001 (2001-09-26) * paragraph [0039] - paragraph [0099]; figures 1-12 *	1	
The present search report has been drawn up for all claims			TECHNICAL FIELDS SEARCHED (IPC)
			H01H
Place of search		Date of completion of the search	Examiner
Munich		12 March 2008	Nieto, José Miguel
CATEGORY OF CITED DOCUMENTS			
X : particularly relevant if taken alone		T : theory or principle underlying the invention	
Y : particularly relevant if combined with another document of the same category		E : earlier patent document, but published on, or after the filing date	
A : technological background		D : document cited in the application	
O : non-written disclosure		L : document cited for other reasons	
P : intermediate document		& : member of the same patent family, corresponding document	

1

EPO FORM 1503 03.82 (P/M/C01)

**ANNEX TO THE EUROPEAN SEARCH REPORT
ON EUROPEAN PATENT APPLICATION NO.**

EP 07 11 7582

This annex lists the patent family members relating to the patent documents cited in the above-mentioned European search report. The members are as contained in the European Patent Office EDP file on The European Patent Office is in no way liable for these particulars which are merely given for the purpose of information.

12-03-2008

Patent document cited in search report	Publication date	Patent family member(s)	Publication date
US 2002027065 A1	07-03-2002	NONE	
US 7102093 B1	05-09-2006	NONE	
JP 2005050709 A	24-02-2005	NONE	
JP 2003297181 A	17-10-2003	NONE	
EP 1137028 A	26-09-2001	CN 1314688 A	26-09-2001
		KR 20010090440 A	18-10-2001
		TW 503415 B	21-09-2002
		US 2001022270 A1	20-09-2001

EPO FORM P0459

For more details about this annex : see Official Journal of the European Patent Office, No. 12/82