



(11) **EP 2 050 682 A1**

(12) **EUROPEAN PATENT APPLICATION**

(43) Date of publication:  
**22.04.2009 Bulletin 2009/17**

(51) Int Cl.:  
**B65D 8/04 (2006.01)**

(21) Application number: **08166733.9**

(22) Date of filing: **16.10.2008**

(84) Designated Contracting States:  
**AT BE BG CH CY CZ DE DK EE ES FI FR GB GR HR HU IE IS IT LI LT LU LV MC MT NL NO PL PT RO SE SI SK TR**  
Designated Extension States:  
**AL BA MK RS**

(71) Applicant: **Stolzman, Michael D.**  
**Lake Forest, IL 60045 (US)**

(72) Inventor: **Kuzelka, Kenneth J.**  
**Lake Forest, IL 60045 (US)**

(30) Priority: **17.10.2007 US 974950**

(74) Representative: **Heikkinen, Esko Juhani**  
**Berggren Oy Ab**  
**P.O. Box 16**  
**FIN-00101 Helsinki (FI)**

(54) **Drum with sidewall threaded to plastic base or chime**

(57) A shipping and storage drum comprises a unitary base of synthetic resin comprising a circular center wall connected at a peripheral edge to a connecting ring having an upwardly opening threaded annular channel. A tubular fiberboard sidewall (12) defines a peripherally closed space (14) having open opposite upper (16) and lower (18) ends. The tubular sidewall lower end is threaded into the threaded annular channel to close the sidewall lower end. The shipping and storage drum may also comprise a chime (24) of synthetic resin comprising a connecting ring having a downwardly opening threaded annular channel receiving the upper end of the tubular sidewall, the chime for removably receiving a cover.

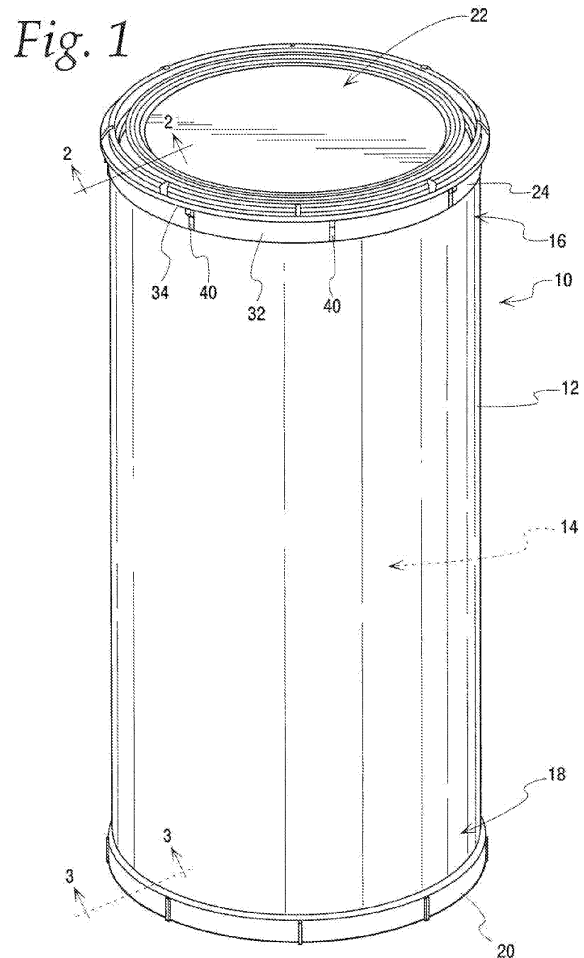

**EP 2 050 682 A1**

**Description**

## FIELD OF THE INVENTION

**[0001]** This invention relates to containers and, more particularly, to a drum with a sidewall threaded to a plastic base or chime.

## BACKGROUND OF THE INVENTION

**[0002]** In one form of conventional shipping and storage container, a tubular sidewall is formed of fibrous material or other material. Conventionally, metal retaining rings are provided at opposite ends of the sidewall for securing closure walls there across. Such metal retaining rings are relatively costly and heavy and are not fully satisfactory in the formation of a low cost shipping and storage container.

**[0003]** Ultimately, the container may be sent to, for example, an incinerator for destruction. If a metal retaining ring is used, then it is necessary to remove the metal from the incinerator.

**[0004]** Also, in the formation of such a prior container, a rolling operation is required to seal the retaining ring to the drum.

**[0005]** An alternative to such prior containers is described in U.S. Patent No. 4,805,798, which discloses a container in the form of a tubular fiber sidewall having a connecting ring molded of synthetic resin in situ in association with an end portion of the sidewall. Such a container requires a die press adapted to support the sidewall while molding the connecting ring to the sidewall.

**[0006]** Other alternatives are disclosed in Patent Nos. 5,160,061 and 5,215,207 which disclose a connecting ring adhered to a container sidewall by vibrational welding.

**[0007]** The present invention is directed to further improvements in shipping and storage containers.

## SUMMARY OF THE INVENTION

**[0008]** In accordance with the invention, there is disclosed a drum with a sidewall threaded to a plastic base or chime.

**[0009]** Broadly, there is disclosed a shipping and storage drum comprising a unitary base of synthetic resin comprising a circular center wall connected at a peripheral edge to a connecting ring having an upwardly opening threaded annular channel. A tubular sidewall defines a peripherally closed space having an upper end and a lower end. The lower end of the tubular sidewall is threaded into the threaded annular channel to close the lower end of the sidewall.

**[0010]** In accordance with the invention, the shipping and storage drum may also comprise a chime of synthetic resin comprising a connecting ring having a downwardly opening threaded annular channel receiving the upper end of the tubular sidewall, the chime for removably re-

ceiving a cover.

**[0011]** It is a feature of the invention that the sidewall is a fiberboard sidewall.

**[0012]** It is another feature of the invention to provide a sealant disposed in the channel.

**[0013]** It is a further feature of the invention that the threaded annular channel comprises opposite facing inner and outer walls each having a continuous thread. The inner wall thread may be offset from the outer wall thread.

**[0014]** It is still another feature of the invention that the thread is triangular in cross-section.

**[0015]** It is still another feature of the invention that the drum has a diameter in the range of about 30.5 to 76.2 cm (12 to 30 inches).

**[0016]** It is still a further feature of the invention that the annular channel has a thread extending at least two revolutions of the connecting ring.

**[0017]** There is disclosed in accordance with another aspect of the invention a shipping and storage drum comprising a unitary base of synthetic resin comprising a circular center wall connected at a peripheral edge to a connecting ring having an upwardly opening threaded annular channel. A tubular fiberboard sidewall defines a peripherally closed space having open opposite upper and lower ends. The tubular sidewall lower end is threaded into the threaded annular channel to close the sidewall lower end.

**[0018]** Further features and advantages of the invention will be readily apparent from the specification and from the drawings.

## BRIEF DESCRIPTION OF THE DRAWINGS

**[0019]**

Fig. 1 is a perspective view of a shipping and storage drum in accordance with the invention;

Fig. 2 is a partial, sectional view taken along the line 2-2 of Fig. 1; and

Fig. 3 is a sectional view taken along the line 3-3 of Fig. 1.

## DETAILED DESCRIPTION OF THE INVENTION

**[0020]** As illustrated in Figs. 1-3 of the drawings, a container in the form of a shipping and storage drum 10 includes a fibrous tubular sidewall 12, such as fiberboard. The sidewall 12 defines a right cylinder defining a peripherally closed space 14 and having an upper end 16 and a lower end 18. The sidewall 12 is formed by rolling paper layers around a forming tube with an adhesive between layers to bond the layers.

**[0021]** The space 14 is closed at a lower end by a bottom closure or base 20 fixedly secured to the sidewall lower end 18, as described below. The upper end of the space 14 is selectively closed by a second closure comprising a cover 22 removably secured to a chime 24. The

chime 24 is fixedly secured to the sidewall upper end 16, as described below. Particularly, in accordance with the invention, the connection of the sidewall 12 to the base 20 and chime 24 comprises a threaded connection.

**[0022]** Referring particularly to Fig. 2, the chime 24 comprises a connecting ring 26 having a downwardly opening annular channel 28 receiving the tubular sidewall upper end 16. The connecting ring 26 comprises an inner wall 30 spaced from an outer wall 32 facing one another in the channel 28. A flange 34 extends outwardly from a top end of the outer wall 32. An annular ring 36 extends upwardly above the channel 28. The annular ring 36 includes a threaded outer wall 38 for threadably receiving the cover 22 in a conventional manner. A plurality of support ribs 40 are spaced about the circumference of the outer wall 32 below the flange 34.

**[0023]** Although the chime 24 is illustrated including a threaded connection with the cover 22, the interconnection could be a self locking cover or use a locking band, as will be apparent.

**[0024]** In accordance with the invention, the connecting ring inner wall 30 includes an inner thread 42 disposed in the channel 28 facing the outer wall 32. Similarly, the outer wall 32 includes an outer thread 44 extending into the annular channel 28 facing the inner wall 30. The threads 42 and 44 are triangular in configuration to comprise a sharp thread. Each thread 42 and 44 extends about two revolutions of the annular channel 28 with the threads 42 and 44 being offset about 180° so that the threads of the inner thread 42 fall midway between threads of the outer thread 44, and vice versa, as is apparent.

**[0025]** The chime 24 is secured to the sidewall 12 by threading the sidewall 12 into the threaded annular channel 28. The threads 42 and 44 dig into the fiberboard sidewall 12 at the upper end 16. In the drawings, the channel 28 includes a draft for molding. However, the draft is somewhat exaggerated in the drawings.

**[0026]** A sealant of silicone or the like can be used to fill the channel 28, before or after threading, to create a water tight seal between the sidewall 12 and the chime 24.

**[0027]** Referring to Fig. 3, the base 20 comprises a circular center wall 50 connected at a peripheral edge to a connecting ring 52 having an upwardly opening annular channel 54. The connecting ring 52 comprises an inner wall 56 and an outer wall 58. The inner wall 56 includes an inner thread 60 in the annular channel 54 facing the outer wall 58. The outer wall 58 includes an outer thread 62 in the annular channel 54 facing the inner wall 56. The threads 60 and 62 are triangular in cross-section to comprise a sharp thread. The threads 60 and 62 are continuous and extend about two revolutions of the base 20 and are offset from one another, as with the threads of the chime 24, discussed above. The tubular sidewall lower end 18 is threaded into the annular channel 54 to close the lower end of the sidewall 18. As recited previously, a sealant could be used in the annular channel 54 before

or after threading the sidewall 12 to the base 20.

**[0028]** In the illustrated embodiment of the invention, the drum 10 comprises a shipping and storage drum with the sidewall 12 having a diameter in the range of about 30.5 to 76.2 cm (12 to 30 inches). The base 20 and chime 24 are molded of a synthetic resin, such as high density polyethylene.

**[0029]** Thus, in accordance with the invention, a drum 10 is provided consisting of two component elements, namely plastic and fiber. After the drum 10 has completed its useful life, the plastic and fiber parts can be separated and recycled, as necessary.

**[0030]** The drum provides positive securement of the chime 24 and base 20 to the sidewall 12 without having to mold the same directly thereon. Moreover, the securement is accomplished with a simple threading operation which is optionally supplemented with a sealant.

**[0031]** The disclosed embodiment of the invention is illustrative of the broad inventive concepts comprehended.

## Claims

1. A shipping and storage drum comprising:
  - a unitary base of synthetic resin comprising a circular center wall connected at a peripheral edge to a connecting ring having an upwardly opening threaded annular channel; and
  - a tubular sidewall (12) defining a peripherally closed space having an upper end (16) and a lower end (18),
- wherein the lower end of the tubular sidewall is threaded into the threaded annular channel to close the lower end of the sidewall.
2. The shipping and storage drum of claim 1 further comprising a chime (24) of synthetic resin comprising a connecting ring having a downwardly opening threaded annular channel receiving the upper end of the tubular sidewall, the chime for removable receiving a cover.
3. The shipping and storage drum of claim 1 or 2 wherein the sidewall is a fiberboard sidewall.
4. The shipping and storage drum of claim 1 or 2 wherein the sidewall is formed of paper.
5. The shipping and storage drum of any preceding claim further comprising a sealant disposed in the channel.
6. The shipping and storage drum of any preceding claim wherein the threaded annular channel comprises opposite facing inner and outer walls each

- having a continuous thread.
7. The shipping and storage drum of claim 6 wherein the inner wall thread is offset from the outer wall thread. 5
8. The shipping and storage drum of any preceding claim wherein the thread is triangular in cross section. 10
9. The shipping and storage drum of any preceding claim wherein the drum has a diameter in the range of about 30.5 to 76.2 cm (12 to 30 inches).
10. The shipping and storage drum of any preceding claim wherein the annular channel has a thread extending at least two revolutions of the connecting ring. 15
11. A shipping and storage drum comprising: 20
- a unitary base of synthetic resin comprising a circular center wall connected at a peripheral edge to a connecting ring having an upwardly opening threaded annular channel; and 25
- a tubular fiberboard sidewall (12) defining a peripherally closed space (14) having open opposite upper (16) and lower (18) ends,
- wherein the tubular sidewall lower end is threaded into the threaded annular channel to close the sidewall lower end. 30
12. The shipping and storage drum of claim 11 further comprising a chime (24) of synthetic resin comprising a connecting ring having a downwardly opening threaded annular channel receiving the upper end of the tubular sidewall, the chime for removable receiving a cover. 35
13. The shipping and storage drum of claim 11 or 12 wherein the sidewall is a fiberboard sidewall. 40
14. The shipping and storage drum of claim 11 or 12 wherein the sidewall is formed of paper. 45
15. The shipping and storage drum of any claim 11 to 14 further comprising a sealant disposed in the channel. 50
16. The shipping and storage drum of any claim 11 to 15 wherein the threaded annular channel comprises opposite facing inner and outer walls each having a continuous thread. 55
17. The shipping and storage drum of claim 16 wherein the inner wall thread is offset from the outer wall thread.
18. The shipping and storage drum of any claim 11 to 17 wherein the tread is triangular in cross section.
19. The shipping and storage drum of any claim 11 to 18 wherein the drum has a diameter in the range of about 30.5 to 76.2 cm (12 to 30 inches).
20. The shipping and storage drum of any claim 11 to 19 wherein the annular channel has a thread extending at least two revolutions of the connecting ring.

Fig. 1

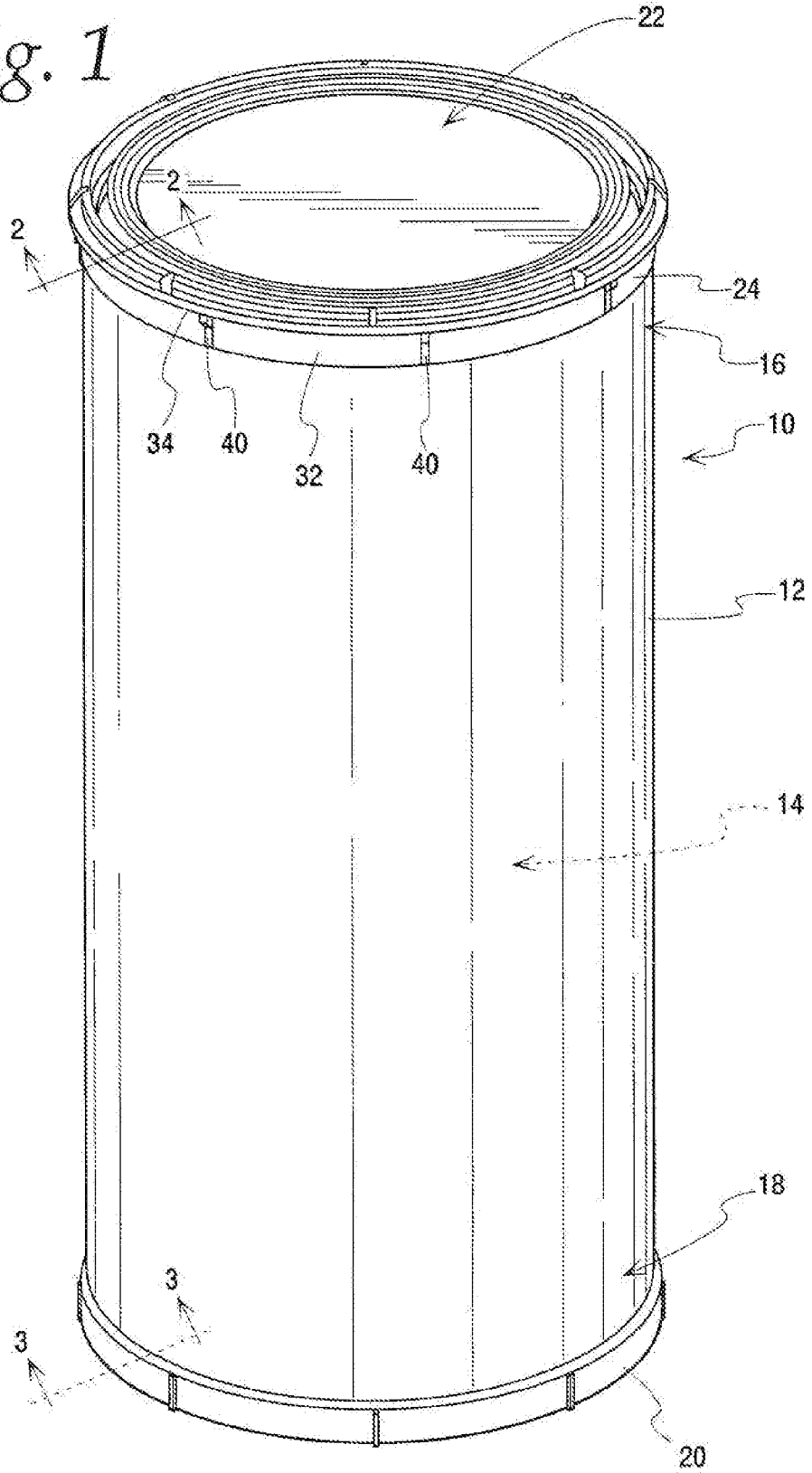

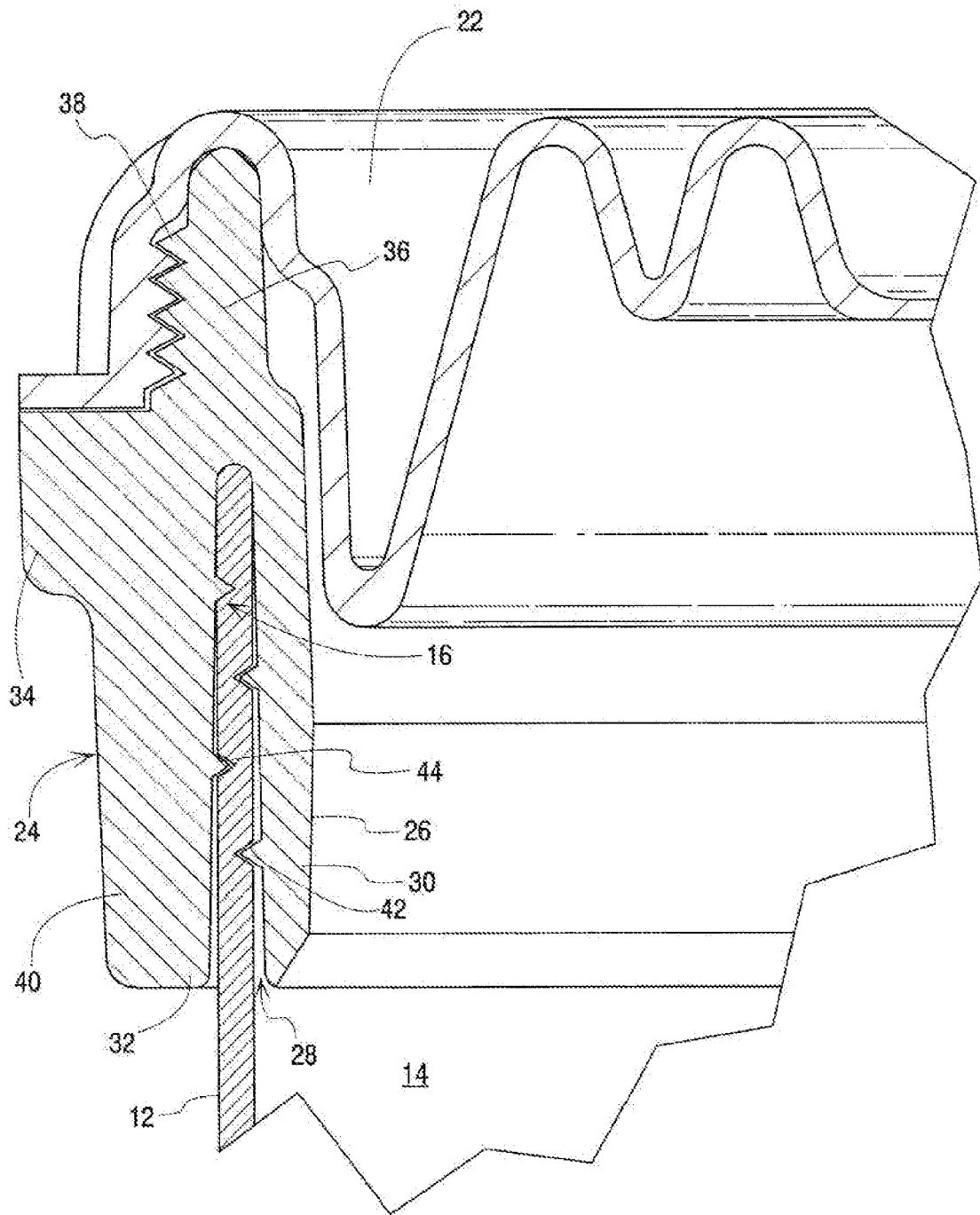

*Fig. 2*

Fig. 3

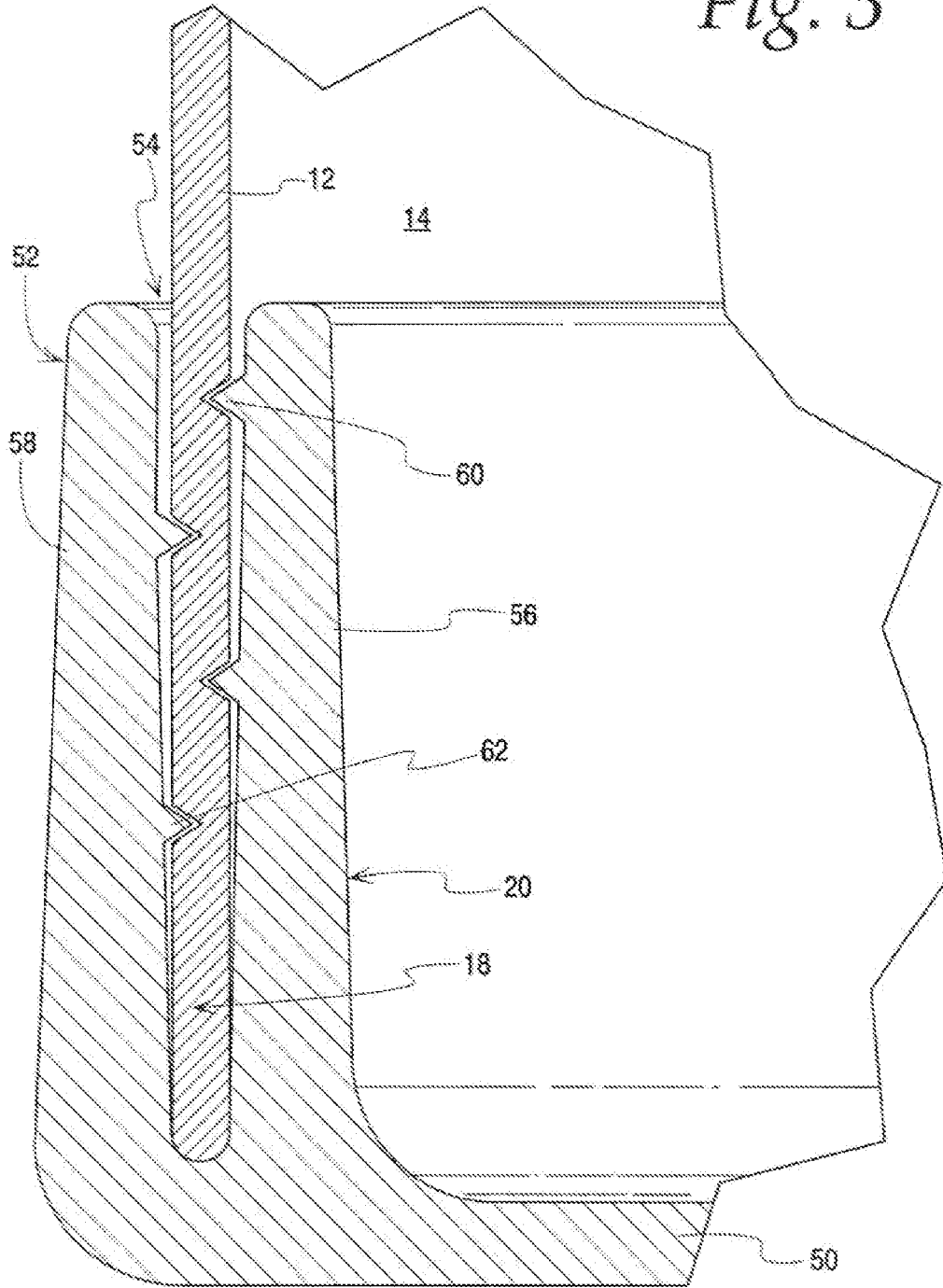



EUROPEAN SEARCH REPORT

Application Number  
EP 08 16 6733

DOCUMENTS CONSIDERED TO BE RELEVANT			
Category	Citation of document with indication, where appropriate, of relevant passages	Relevant to claim	CLASSIFICATION OF THE APPLICATION (IPC)
X A	US 4 241 864 A (KESSLER MILTON [US]) 30 December 1980 (1980-12-30) * abstract; figures *	1-5, 11-15 6-10, 16-20	INV. B65D8/04
A	WO 93/17920 A (AKERLUND & RAUSING LICENS AB [SE]) 16 September 1993 (1993-09-16) * abstract; figures *	1-5,9, 11-15,19	
A	GB 2 331 068 A (ASSOCIATED MARKETING DIRECTION [GB]) 12 May 1999 (1999-05-12) * abstract; figures *	1-4, 11-14	
A	US 6 325 231 B1 (KETTING WILLEM-HENDRIK [NL] ET AL) 4 December 2001 (2001-12-04) * abstract; figures *	1-4, 11-14	
A,D	US 5 215 207 A (STOLZMAN MICHAEL D [US]) 1 June 1993 (1993-06-01)		
A	US 4 700 867 A (DUTT HERBERT V [US] ET AL) 20 October 1987 (1987-10-20)		
			TECHNICAL FIELDS SEARCHED (IPC)
			B65D
The present search report has been drawn up for all claims			
Place of search		Date of completion of the search	Examiner
The Hague		8 January 2009	Serrano Galarraga, J
CATEGORY OF CITED DOCUMENTS			
X : particularly relevant if taken alone		T : theory or principle underlying the invention	
Y : particularly relevant if combined with another document of the same category		E : earlier patent document, but published on, or after the filing date	
A : technological background		D : document cited in the application	
O : non-written disclosure		L : document cited for other reasons	
P : intermediate document		& : member of the same patent family, corresponding document	

2  
EPO FORM 1503 03.82 (P04C01)



ANNEX TO THE EUROPEAN SEARCH REPORT  
ON EUROPEAN PATENT APPLICATION NO.

EP 08 16 6733

This annex lists the patent family members relating to the patent documents cited in the above-mentioned European search report. The members are as contained in the European Patent Office EDP file on  
The European Patent Office is in no way liable for these particulars which are merely given for the purpose of information.

08-01-2009

Patent document cited in search report		Publication date	Patent family member(s)	Publication date
US 4241864	A	30-12-1980	NONE	
WO 9317920	A	16-09-1993	SE 507647 C2 SE 9200677 A	29-06-1998 06-09-1993
GB 2331068	A	12-05-1999	GB 2318569 A	29-04-1998
US 6325231	B1	04-12-2001	AT 215481 T AU 750004 B2 AU 1670599 A BR 9814976 A CA 2310449 A1 CN 1279642 A CZ 20001863 A3 WO 9925622 A1 EP 1034117 A1 ES 2174523 T3 HU 0100109 A2 ID 24948 A IL 134690 A JP 2001523625 T PL 339923 A1 PT 1034117 T SK 7272000 A3 TR 200001394 T2	15-04-2002 04-07-2002 07-06-1999 03-10-2000 27-05-1999 10-01-2001 12-12-2001 27-05-1999 13-09-2000 01-11-2002 28-05-2001 31-08-2000 10-04-2003 27-11-2001 15-01-2001 30-09-2002 07-11-2000 21-11-2000
US 5215207	A	01-06-1993	NONE	
US 4700867	A	20-10-1987	NONE	

**REFERENCES CITED IN THE DESCRIPTION**

*This list of references cited by the applicant is for the reader's convenience only. It does not form part of the European patent document. Even though great care has been taken in compiling the references, errors or omissions cannot be excluded and the EPO disclaims all liability in this regard.*

**Patent documents cited in the description**

- US 4805798 A [0005]
- US 5160061 A [0006]
- US 5215207 A [0006]