

(19)



(11)

**EP 2 052 816 B1**

(12)

**EUROPEAN PATENT SPECIFICATION**

(45) Date of publication and mention of the grant of the patent:  
**11.12.2013 Bulletin 2013/50**

(51) Int Cl.:  
**B25G 1/06 (2006.01)**

(21) Application number: **08166276.9**

(22) Date of filing: **09.10.2008**

(54) **Control Device For Angle Adjustable Hand Tool**

Steuerungsvorrichtung für Handwerkzeug mit einstellbarem Winkel

Dispositif de commande pour outil manuel d'angle réglage

(84) Designated Contracting States:  
**AT BE BG CH CY CZ DE DK EE ES FI FR GB GR HR HU IE IS IT LI LT LU LV MC MT NL NO PL PT RO SE SI SK TR**

(30) Priority: **26.10.2007 CN 200710163486**

(43) Date of publication of application:  
**29.04.2009 Bulletin 2009/18**

(73) Proprietor: **Proxene Tools Co., Ltd. Kang Hsiang, Taichung County (TW)**

(72) Inventor: **Wu, Arthur Shen Kang Hsiang, Taichung (TW)**

(74) Representative: **Lang, Christian et al LangPatent Anwaltskanzlei Rosenheimer Strasse 139 81671 München (DE)**

(56) References cited:  
**EP-A1- 1 533 081 US-A1- 2004 083 861**  
**US-A1- 2004 144 218 US-B1- 6 216 317**  
**US-B1- 6 857 341 US-B2- 7 131 356**  
**US-B2- 7 168 346**

**EP 2 052 816 B1**

Note: Within nine months of the publication of the mention of the grant of the European patent in the European Patent Bulletin, any person may give notice to the European Patent Office of opposition to that patent, in accordance with the Implementing Regulations. Notice of opposition shall not be deemed to have been filed until the opposition fee has been paid. (Art. 99(1) European Patent Convention).

**Description****FIELD OF THE INVENTION****BACKGROUND OF THE INVENTION****(1) FIELD OF THE INVENTION**

[0001] The present invention relates to a control device for angle adjustable hand tool.

**(2) DESCRIPTION OF THE PRIOR ART**

[0002] A conventional angle adjustable hand tool is disclosed in US Pat. No. 7131356 which includes a spring and a positioning plate at the front end of the adjusting member and the positioning plate supports the driving head when the adjusting member is disengaged from the teeth of the driving head such that the driving head does not fall suddenly. However, extra parts are required and the assembly processes becomes complicated and difficult.

[0003] Another conventional angle adjustable hand tool is disclosed in US Pat. No. 7168346 which includes a button and a hole is defined in the center of the button so as to accommodate a second connection member. This requires a larger area for the button. When a small scale of hand tool is manufactured, the area button becomes a difficult part to be manufactured and a small area of button might be broken when drilling the hole at its center.

[0004] Further, EP 1533081, US 6857341, US 6216317, US 2004083861 and US 7131356 also disclose similar adjustable hand tool, which include a handle and a head that is angle-adjustable to the handle.

[0005] The present invention intends to provide a control device for an angle adjustable hand tool which includes a simple and compact structure and effectively control the driving head during the process for setting its angle.

**SUMMARY OF THE INVENTION**

[0006] The present invention relates to an angle adjustable hand tool which comprises a handle having a first connection end and a first hole is defined axially in the first connection end so as to receive a spring and a pawl therein. A second hole is defined in the first connection end and perpendicularly communicates with the first hole so as to receive another spring and button therein. A driving head includes a driving member and a second connection end which is pivotably connected to the first connection end and includes a second engagement end. The pawl is includes a first engagement end which is removably engaged with the second engagement end. At least one first flat surface is defined in a shank of the pawl and a first contact surface connects the at least one first flat surface. The button includes at least one second

flat surface which is matched with the at least one first flat surface of the pawl. A recess is defined in the button and located substantially perpendicular to the at least one second flat surface. A second contact surface connects the recess.

[0007] When the button is pushed, the second contact surface is disengaged from the first contact surface and the pawl is then located in the recess of the button so that the driving head can be pivoted and the second engagement end of the driving head moves over the first engagement end of the pawl to adjust the angle of the driving head relative to the handle. The first engagement end of the pawl is engaged with the second engagement end again when releasing the button.

[0008] The primary object of the present invention is to provide a control device for adjusting the driving head relative to the handle, the driving head is kept being engaged with a pawl when pivoting to a new angle. The control device is easily to be assembled and operated.

[0009] The present invention will become more obvious from the following description when taken in connection with the accompanying drawings which show, for purposes of illustration only, a preferred embodiment in accordance with the present invention.

**BRIEF DESCRIPTION OF THE DRAWINGS****[0010]**

Fig. 1 is an exploded view to show the control device of the angle adjustable hand tool of the present invention;

Fig. 1-1 shows the button and the spring for biasing the button;

Fig. 1-2 shows the pawl and the spring for biasing the pawl;

Fig. 2 shows that the pawl is engaged with the teeth of the driving head;

Fig. 3 shows a partial cross sectional view of the control device of the hand tool;

Fig. 3-1 is a cross sectional view taken along line a-a in Fig. 3;

Fig. 4 is an enlarged cross sectional view to show that the pawl is engaged with the teeth of the driving head;

Fig. 5 is a plain view to show the button is pushed and pawl is not positioned by the button;

Fig. 6 is a side partial cross sectional view to show that the button is pushed and the driving head is pivoted;

Fig. 6-1 is a cross sectional view taken along line b-b in Fig. 6;

Fig. 7 is an enlarged cross sectional view to show the pawl is located in the recess of the button when the button is pushed;

Fig. 8 is an exploded view to show another embodiment of the control device of the present invention; Fig. 8-1 shows the button and the spring for biasing

the button of the embodiment in Fig. 8;  
 Fig. 8-2 shows the pawl and the spring for biasing the pawl of the embodiment in Fig. 8;  
 Fig. 9 is a plain view to show the button is pushed and pawl is positioned by the button for the embodiment of Fig. 8;  
 Fig. 10 is a side partial cross sectional view to show that the button is not pushed and the pawl is engaged with the driving head for the embodiment of Fig. 8;  
 Fig. 10-1 is a cross sectional view taken along line c-c in Fig. 10;  
 Fig. 11 is a cross sectional view to show that the pawl is engaged with the teeth of the driving head;  
 Fig. 12 is a plain view to show the button is pushed and pawl is not positioned by the button for the embodiment of Fig. 8;  
 Fig. 13 is a side partial cross sectional view to show that the button is pushed and the driving head is pivoted for the embodiment of Fig. 8;  
 Fig. 14 is a cross sectional view taken along line d-d in Fig. 13;  
 Fig. 15 shows that the driving member is a ratchet driving member;  
 Fig. 16 shows that the driving member is a box end;  
 Fig. 17 is a plain view to show yet another embodiment of the hand tool;  
 Fig. 18 is a side view of the control device and the hand tool in Fig. 17, and  
 Fig. 19 shows that the pawl is engaged with the teeth in the pin for the hand tool in Fig. 17.

#### DETAILED DESCRIPTION OF THE PREFERRED EMBODIMENTS

**[0011]** Referring to Figs. 1 to 7, the angle adjustable hand tool of the present invention comprises a handle 10 having a first connection end 11 and a first hole 114 is defined axially in the first connection end 11. The first connection end 11 includes two protrusions 112 and a space 111 is defined between the two protrusions 112. A second hole 115 is defined in the first connection end 11 and perpendicularly communicates with the first hole 114. Two respective springs "A", "B" are received in the first and second holes 114, 115 respectively. A driving head 40 includes a driving member 41 such as an open end as show in Fig. 1 or a ratchet driving member as shown in Fig. 15 or a box end as shown in Fig. 16. A second connection end 42 which is pivotably connected between the two protrusions 112 of the first connection end 11 by extending a pin "C" through the two respective first pin holes 113 on the two protrusions 112 and the second pin hole 44 defined through the insertion of the driving head 40. The insertion includes a second engagement end 43 which includes teeth defined therein. The teeth are shaped to include a V-shaped space or U-shaped space defined between the teeth of the second engagement end 43.

**[0012]** A pawl 20 is movably received in the first hole

114 and biased by the spring "A", the pawl 20 includes a first engagement end 21 which is a wedge end and removably engaged with the teeth of the second engagement end 43. A first flat surface 22 is defined in a shank of the pawl 20 and a first contact surface 23 connects the at least one first flat surface 22. A first guide surface 25 connects the first contact surface 23 of the pawl 20.

**[0013]** A button 30 is engaged with the second hole 115 and biased by the spring "B". The button 30 includes a second flat surface 31 which is matched with the first flat surface 22 of the pawl 20. A recess 32 is defined in the button 30 and located substantially perpendicular to the second flat surface 31. A second guide surface 34 is connected between the recess 32 and a second contact surface 33. As shown in Fig. 4, the pawl 20 is pushed by the second contact surface 33 and the spring "B" so that the first engagement end 21 is engaged with the teeth of the second connection end 42 of the driving head 40.

**[0014]** As shown in Figs. 5, 6, 6-1 and 7, when the button 30 is pushed by the user, the button 30 is lowered and the second contact surface 33 is disengaged from the first contact surface 23, the pawl 20 is then located in the recess 32 of the button 30. The pawl 20 is not longer positioned by the second contact surface 33 so that the driving head 40 can be pivoted and the second engagement end 43 of the driving head 40 moves over the first engagement end 21 of the pawl 20 to adjust the angle of the driving head 40 relative to the handle 10. When releasing the button 30, the first engagement end 21 of the pawl 20 is engaged with the second engagement end 43 again and the pawl 20 is positioned by the button 30.

**[0015]** Figs. 8-14 show another embodiment of the control device of the present invention, wherein the pawl 20 includes a slot 24 defined axially therein so as to define two first flat surfaces 22 in two facing insides of the slot 24. Correspondingly, the button 30 includes two second flat surfaces 31 and the recess 32 is located at two respective ends of the two second flat surfaces 31. The shank of the button 30 is movably engaged with the slot 24 and the two second flat surfaces 31 are engaged with the first flat surfaces 22. By this way, the button 30 cannot rotate. The second contact surface 33 connects the recess 32 via the second guide surface 34 which is a curved and convex surface. The operation processes are the same as the first embodiment of the control device.

**[0016]** Figs. 17 to 19 show that the first connection end 11 of the handle 10 includes an insertion and the second connection end 42 of the driving head 40 includes two protrusions with a space defined therebetween so that the insertion of the first connection end 11 of the handle 10 is pivotably connected between the two protrusions of the second connection end 42 by the pin "C". The pawl 20 is movably inserted in the first hole in the first connection end 11 and the button 30 is perpendicularly engaged with the pawl 20 in the first connection end 11. The pin "C" includes a second engagement end "C1" which includes teeth and located in the space between the two

protrusions. The first engagement end 21 of the pawl 20 is engaged with the second engagement end "C1".

**[0017]** When the button 30 is pushed, the second contact surface 33 is disengaged from the first contact surface 23 of the pawl 20 and the pawl 20 is then located in the recess 32 of the button 30. The driving head 40 can be pivoted and the second engagement end C1 of the pin "C" moves over the first engagement end 21 of the pawl 20 to adjust the angle of the driving head 40 relative to the handle 10. The first engagement end 21 of the pawl 20 is engaged with the second engagement end "C1" again when releasing the button 30.

**[0018]** The pawl 20 and the button 30 are directly in contact with each other and the pawl 20 is activated when the button 30 is pushed so that the number of parts can be minimized and the driving head 40 does not drop suddenly when the button 30 is pushed.

## Claims

### 1. An angle adjustable hand tool comprising:

a handle (10) having a first connection end (11) and a first hole (114) defined axially in the first connection end (11), a second hole (115) defined in the first connection end (11) and perpendicularly communicating with the first hole (114), two respective springs (A, B) received in the first and second holes (114, 115) respectively;

a driving head (40) having a driving member (41) and a second connection end (42) which is pivotably connected to the first connection end (11); a second engagement end (43, C1) provided at the driving head (40) or at a pin (C);

a pawl (20) movably received in the first hole (114) and having a first engagement end (21) which is removably engaged with the second engagement end (43, C1), at least one first flat surface (22) defined in a shank of the pawl (20) and a first contact surface (23) connecting the at least one first flat surface (22);

a button (30) engaged with the second hole (115) and including at least one second flat surface (31) which is matched with the at least one first flat surface (22) of the pawl (20), a recess (32) defined in the button (30) and located substantially perpendicular to the at least one second flat surface (31), a second contact surface (33) connecting the recess (32), when the button (30) is pushed, the second contact surface (33) being disengaged from the first contact surface (23) and the pawl (20) is then located in the recess (32) of the button (30) so that the driving head (40) is pivoted and the second engagement end (43, C1) of the driving head (40) moves over the first engagement end (21) of the pawl

(20) to adjust the angle of the driving head (40) relative to the handle (10), the first engagement end (21) of the pawl (20) is engaged with the second engagement end (43) again when releasing the button (30).

2. The hand tool as claimed in claim 1, wherein the first connection end (11) of the handle (10) includes at least one first pin hole (113) and the second connection end (42) of the driving head (40) includes at least one second pin hole (44), a pin (C) extends through the at least one first pin hole (113) and at least one second pin hole (44).

3. The hand tool as claimed in claim 1, wherein the first connection end (11) includes two protrusions (112) and a space (111) is defined between the two protrusions (112), the second connection end (42) of the driving head (40) includes an insertion which is pivotably received in the space (111).

4. The hand tool as claimed in claim 1, wherein the pawl (20) includes a slot (24) defined axially therein so as to define two first flat surfaces (22) and one first contact surface (23).

5. The hand tool as claimed in claim 4, the button (30) includes two second flat surfaces (31) and the recess (32) is located at two respective ends of the two second flat surfaces (31), the second contact surface (33) connects the recess (32).

6. The hand tool as claimed in claim 1, wherein a first guide surface (25) connects the first contact surface (23) of the pawl (20).

7. The hand tool as claimed in claim 1, wherein a second guide surface (34) is connected between the recess (32) and the second contact surface (33).

8. The hand tool as claimed in claim 7, wherein the second guide surface (34) is a curved and convex surface.

9. The hand tool as claimed in claim 1, wherein the second engagement end (43) includes teeth defined therein.

10. The hand tool as claimed in claim 1, wherein the driving member (41) is an open end.

11. The hand tool as claimed in claim 1, wherein the driving member (41) is a box end.

## Patentansprüche

1. Winkeljustierbares Handwerkzeug, das umfasst:

- einen Griff (10), der ein erstes Verbindungsende (11) und ein erstes Loch (114) aufweist, das axial in dem ersten Verbindungsende (11) vorgesehen ist, wobei ein zweites Loch (115) in dem ersten Verbindungsende (11) vorgesehen ist und rechtwinklig mit dem ersten Loch (11A) in Verbindung steht, wobei zwei Federn (A, B) jeweils in dem ersten und dem zweiten Loch (114, 115) aufgenommen sind;
- einen Antriebskopf (40), der ein Antriebselement (41) und ein zweites Verbindungsende (42) aufweist, welches drehbar mit dem ersten Verbindungsende (11) verbunden ist;
- ein zweites Eingriffsende (43, C1), das an dem Antriebskopf (40) oder an einem Stift (C) vorgesehen ist;
- eine Klaue (20), die beweglich in dem ersten Loch (114) aufgenommen ist und die ein erstes Eingriffsende (21) aufweist, welches lösbar mit dem zweiten Eingriffsende (43, C1) in Eingriff steht, wobei mindestens eine erste ebene Fläche (22) in einem Schenkel der Klaue (20) vorgesehen ist und wobei eine erste Kontaktfläche (23) mit der mindestens einen ersten ebenen Fläche (22) verbunden ist;
- einen Knopf (30), der mit dem zweiten Loch (115) in Eingriff steht und mindestens eine zweite ebene Fläche (31) umfasst, die mit der mindestens einen ersten ebenen Fläche (22) der Klaue (20) ausgerichtet ist, wobei eine Ausnehmung (32) in dem Knopf (30) vorgesehen ist und im Wesentlichen rechtwinklig zu der mindestens einen zweiten ebenen Fläche (31) angeordnet ist, wobei eine zweite Kontaktfläche (33) mit der Ausnehmung (32) verbunden ist, wobei wenn der Knopf (30) gedrückt wird, die zweite Kontaktfläche (33) von der ersten Kontaktfläche (23) getrennt wird und die Klaue (20) dann in der Ausnehmung (32) des Knopfes (30) angeordnet ist, so dass der Antriebskopf (40) gedreht wird und sich das zweite Eingriffsende (43, C1) des Antriebskopfes (40) zu dem ersten Eingriffsende (21) der Klaue (20) bewegt, um den Winkel des Antriebskopfes (40) relativ zu dem Griff (10) zu justieren, wobei das erste Eingriffsende (21) der Klaue (20) mit dem zweiten Eingriffsende (43) wieder in Eingriff kommt wenn der Knopf (30) losgelassen wird.
2. Handwerkzeug nach Anspruch 1, wobei das erste Verbindungsende (11) des Griffs (10) mindestens ein erstes Stiftloch (113) umfasst und wobei das zweite Verbindungsende (42) des Antriebskopfes (40) mindestens ein zweites Stiftloch (44) umfasst, wobei sich ein Stift (10) durch das mindestens eine erste Stiftloch (113) und das mindestens eine zweite Stiftloch (44) erstreckt.
3. Handwerkzeug nach Anspruch 1, wobei das erste Verbindungsende (11) zwei Vorsprünge (112) umfasst und ein Raum (111) zwischen den zwei Vorsprünge (112) definiert ist, wobei das zweite Verbindungsende (42) des Antriebskopfes (40) einen Einschub umfasst, der drehbar in den Raum (111) aufgenommen ist.
4. Handwerkzeug nach Anspruch 1, wobei die Klaue (20) einen Schlitz (24) umfasst, der axial darin definiert ist, um zwei erste ebene Flächen (22) und eine erste Kontaktfläche (23) zu definieren.
5. Handwerkzeug nach Anspruch 4, wobei der Knopf (30) zwei zweite ebene Flächen (31) umfasst und wobei die Ausnehmung (32) an zwei entsprechenden Enden der zwei zweiten ebenen Flächen (31) angeordnet ist, wobei die zweite Kontaktfläche (33) mit der Ausnehmung (20) verbunden ist.
6. Handwerkzeug nach Anspruch 1, wobei eine erste Führungsfläche (25) mit der ersten Kontaktfläche (23) der Klaue (20) verbunden ist.
7. Handwerkzeug nach Anspruch 1, wobei eine zweite Führungsfläche (34) die Ausnehmung (32) und die zweite Kontaktfläche (33) verbindet.
8. Handwerkzeug nach Anspruch 7, wobei die zweite Führungsfläche (34) eine gebogene und konvexe Fläche ist.
9. Handwerkzeug nach Anspruch 1, wobei das zweite Eingriffsende (43) Zähne umfasst, die darin definiert sind.
10. Handwerkzeug nach Anspruch 1, wobei das Antriebselement (41) eines vom Typ Gabel ist.
11. Handwerkzeug nach Anspruch 1, wobei das Antriebselement (41) eines vom Typ Ring ist
- Revendications**
1. Outil à main à angle ajustable comprenant :
- une poignée (10) ayant une première extrémité de connexion (11) et un premier trou (114) défini axialement dans la première extrémité de connexion (11), un second trou (115) défini dans la première extrémité de connexion (11) et communiquant perpendiculairement avec le premier trou (114), deux ressorts respectifs (A, B) logés respectivement dans le premier et second trou (114, 115) ;
- une tête d'entraînement (40) ayant un élément d'entraînement (41) et une seconde extrémité

- de connexion (42) qui est reliée de manière pivotante à la première extrémité de connexion (11) ;  
 une seconde extrémité d'encliquetage (43, C1) prévue sur la tête d'entraînement (40) ou sur une cheville (C) ;  
 un cliquet (20) logé de manière mobile dans le premier trou (114) et ayant une première extrémité d'encliquetage (21) qui est encliquetée de manière amovible avec la seconde extrémité d'encliquetage (43, C1), au moins une première surface plate (22) définie dans une tige du cliquet (20) et une première surface de contact (23) reliée à au moins une première surface plate (22) ;  
 un bouton (30) encliqueté avec le second trou (115) et comprenant au moins une seconde surface plate (31) qui correspond à la première surface plate qui existe au moins (22) du cliquet (20), un évidement (32) défini dans le bouton (30) et situé substantiellement perpendiculairement à la seconde surface plate qui existe au moins (31), une seconde surface de contact (33) reliée à l'évidement (32) lorsque le bouton (30) est poussé, la seconde surface de contact (33) étant désengagée de la première surface de contact (23) et la tige (20) est ensuite située dans l'évidement (32) du bouton (30) si bien que la tête d'entraînement (40) est pivotée et la seconde extrémité d'encliquetage (43, C1) de la tête d'entraînement (40) se déplace sur la première extrémité d'encliquetage (21) du cliquet (20) pour ajuster l'angle de la tête d'entraînement (40) par rapport à la poignée (10), la première extrémité d'encliquetage (21) du cliquet (20) est encliquetée à nouveau avec la seconde extrémité d'encliquetage (43) lorsque le bouton (30) est relâché.
- 2.** Outil à main selon la revendication 1 dans lequel la première extrémité de connexion (11) de la poignée (10) comprend au moins un premier trou de cheville (113) et la seconde extrémité de connexion (42) de la tête d'entraînement (40) comprend au moins un second trou de cheville (44), une cheville (C) s'étend à travers le premier trou de cheville qui existe au moins (113) et au moins un second trou de cheville (44).
- 3.** Outil à main selon la revendication 1 dans lequel la première extrémité de connexion (11) comprend deux saillies (112) et un espace (111) est défini entre les deux saillies (112), la seconde extrémité de connexion (42) de la tête d'entraînement (40) comprend un insert qui est logé de manière pivotante dans l'espace (111).
- 4.** Outil à main selon la revendication 1 dans lequel le cliquet (20) comprend une fente (24) qui y est définie axialement de manière à définir deux premières surfaces plates (22) et une première surface de contact (23).
- 5.** Outil à main selon la revendication 4, le bouton (30) comprend deux secondes surfaces plates (31) et l'évidement (32) est situé à deux extrémités respectives des deux secondes surfaces plates (31), la seconde surface de contact (33) est reliée à l'évidement (32).
- 6.** Outil à main selon la revendication 1 dans lequel une première surface de guidage (25) est reliée à la première surface de contact (23) du cliquet (20).
- 7.** Outil à main selon la revendication 1 dans lequel une seconde surface de guidage (34) est reliée entre l'évidement (32) et la seconde surface de contact (33).
- 8.** Outil à main selon la revendication 7 dans lequel la seconde surface de guidage (34) est une surface courbée et convexe.
- 9.** Outil à main selon la revendication 1 dans lequel la seconde extrémité de connexion (43) comprend des dents qui y sont définies.
- 10.** Outil à main selon la revendication 1 dans lequel l'élément d'entraînement (41) est une extrémité ouverte.
- 11.** Outil à main selon la revendication 1 dans lequel l'élément d'entraînement (41) est une extrémité fermée.

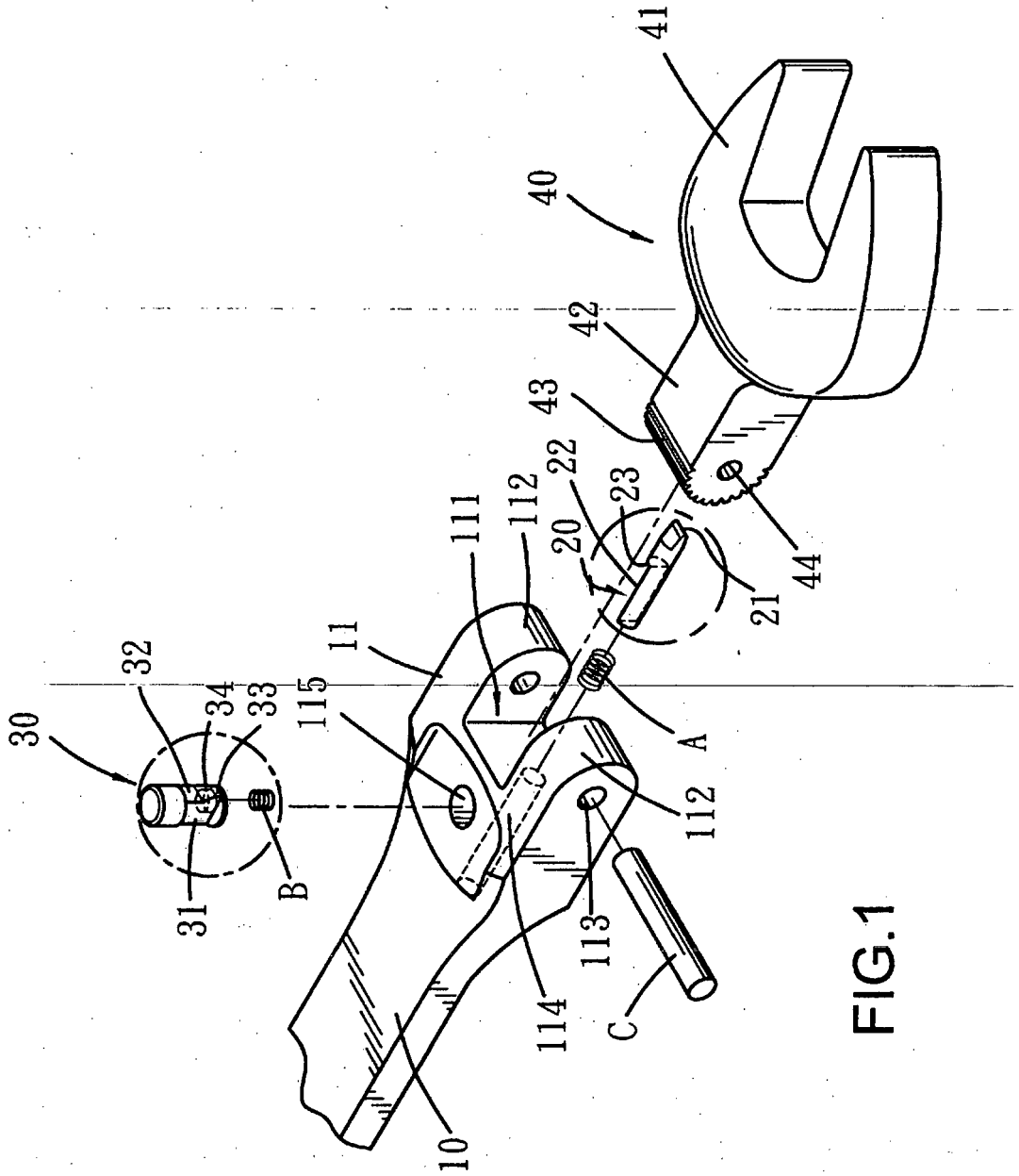

FIG.1

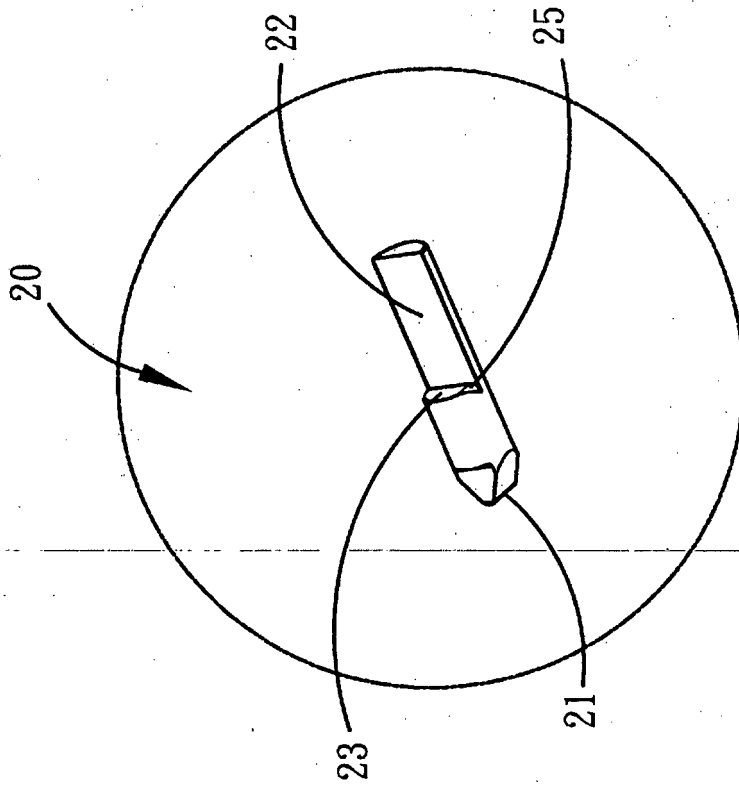

FIG.1-2

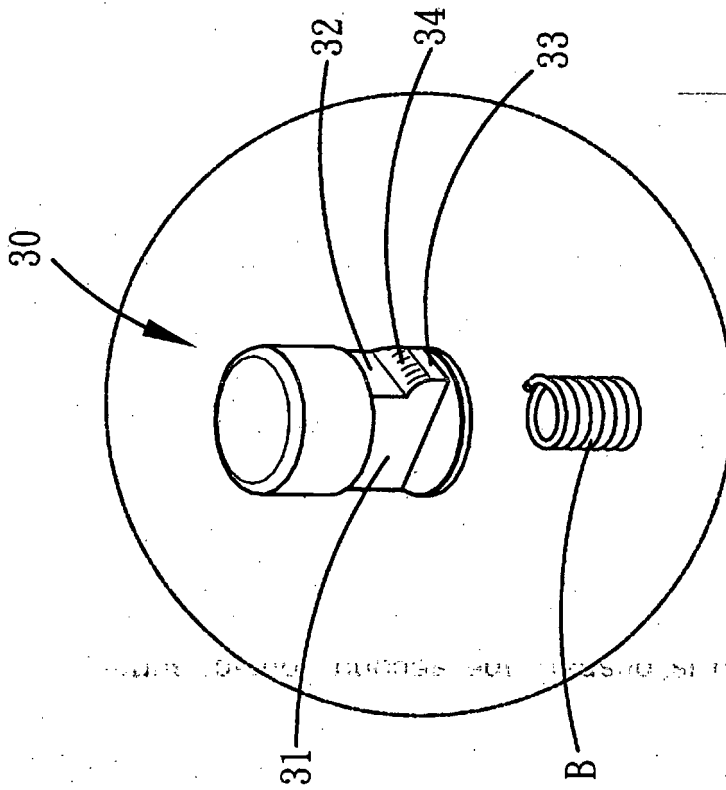
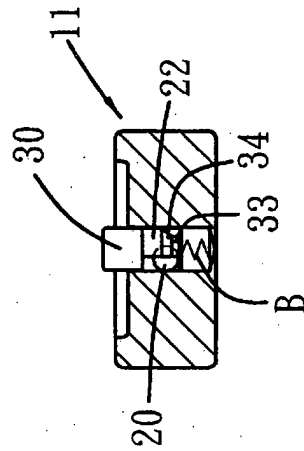
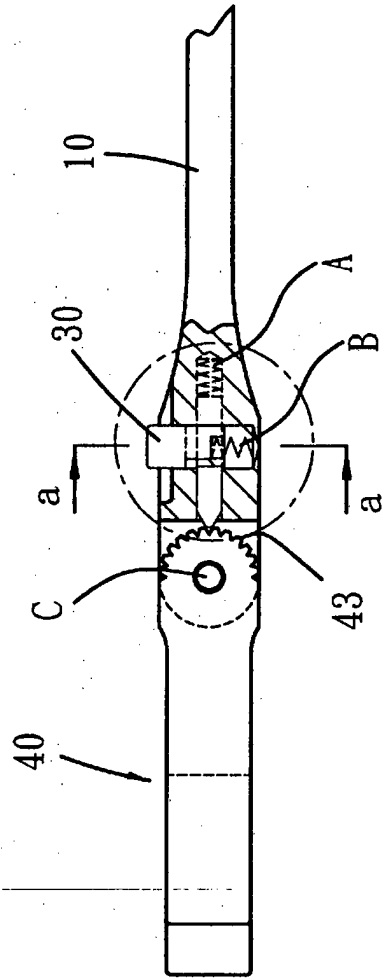
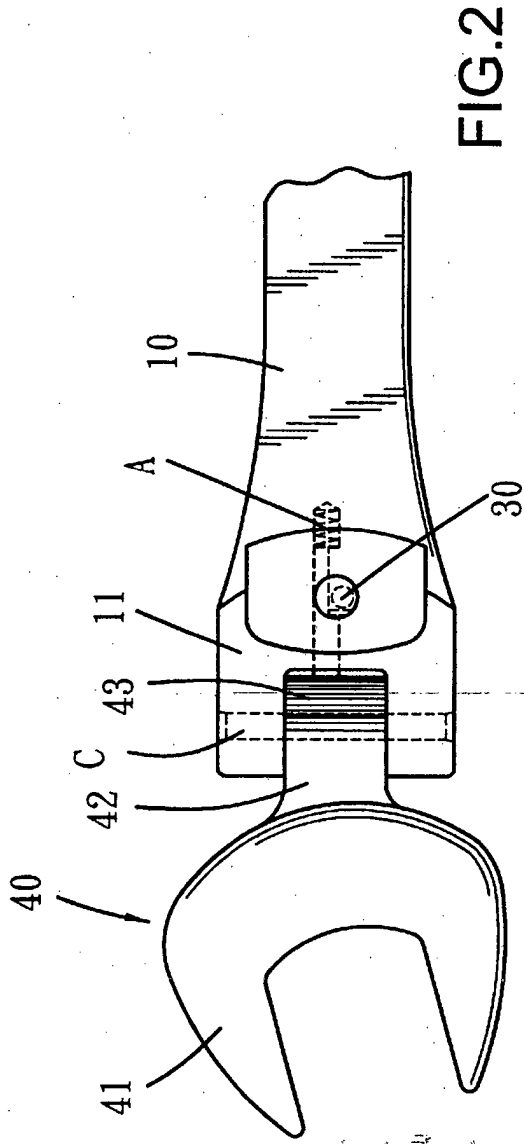

FIG.1-1



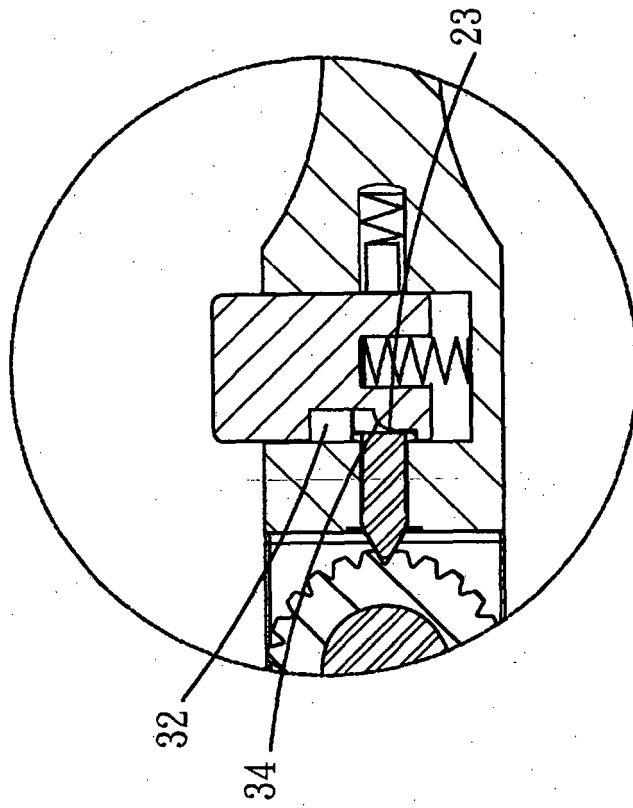

FIG.4

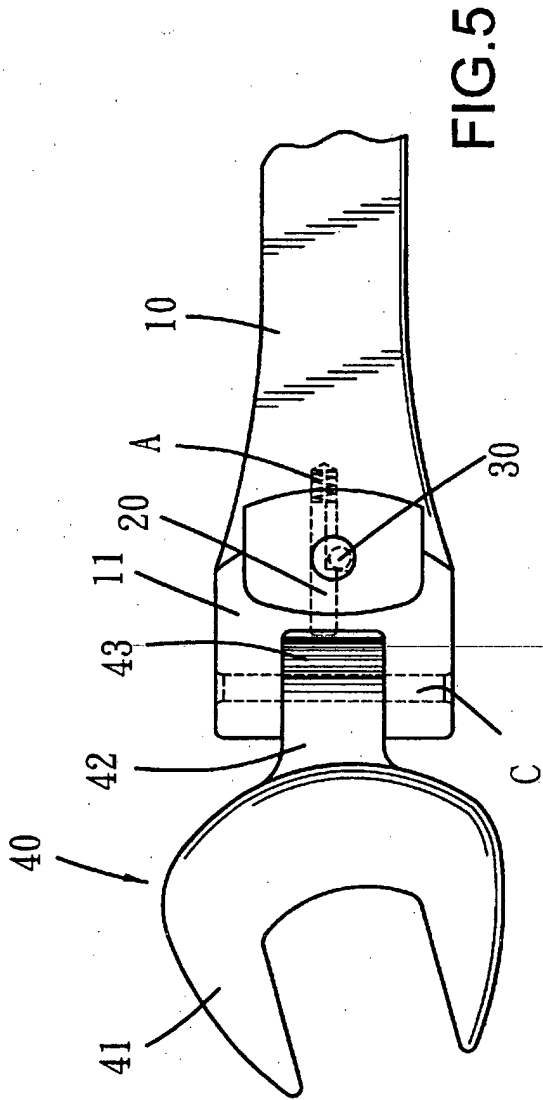

FIG. 5

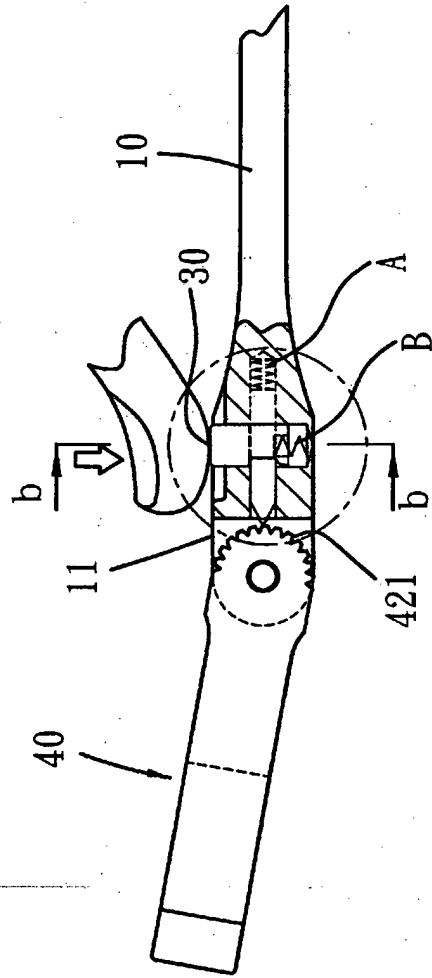

FIG. 6

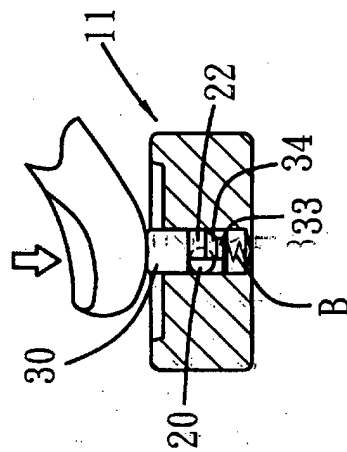

FIG. 6-1

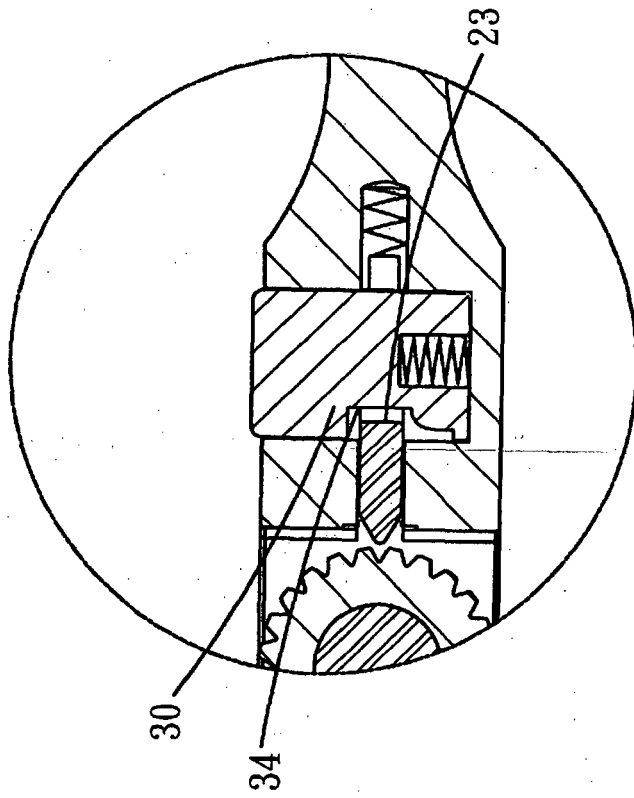

FIG. 7

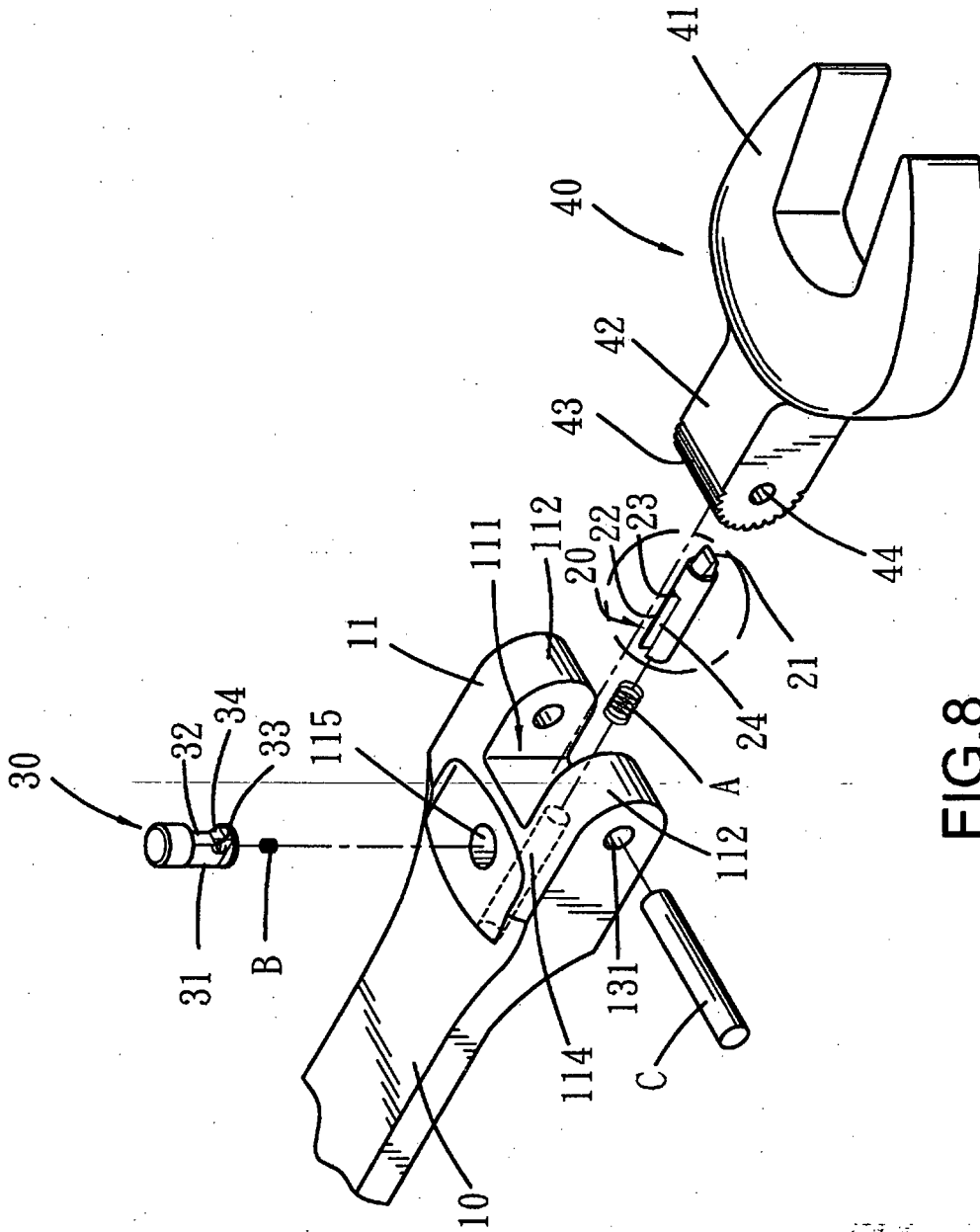

FIG.8

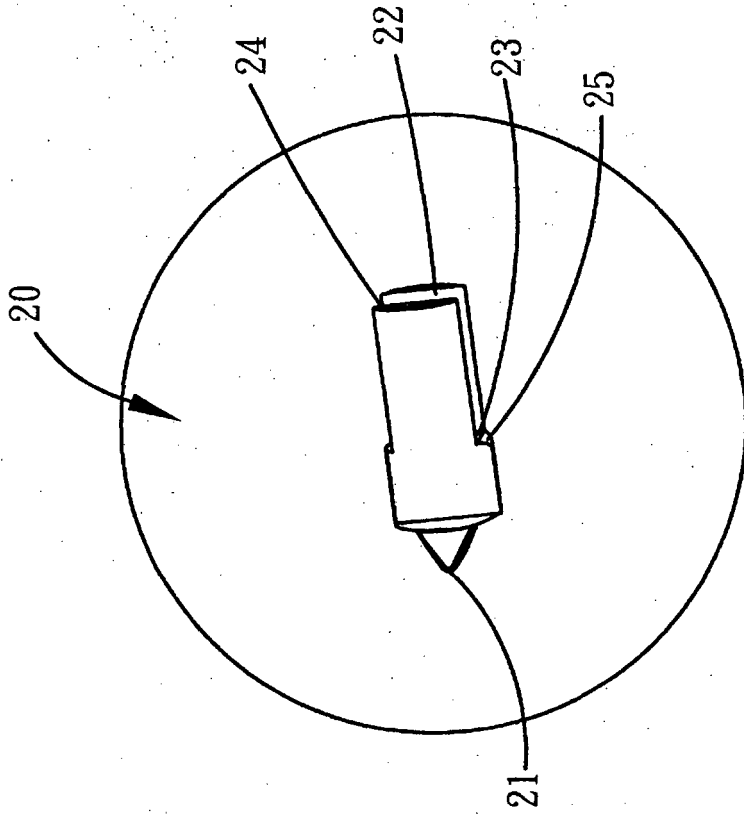

FIG. 8-2

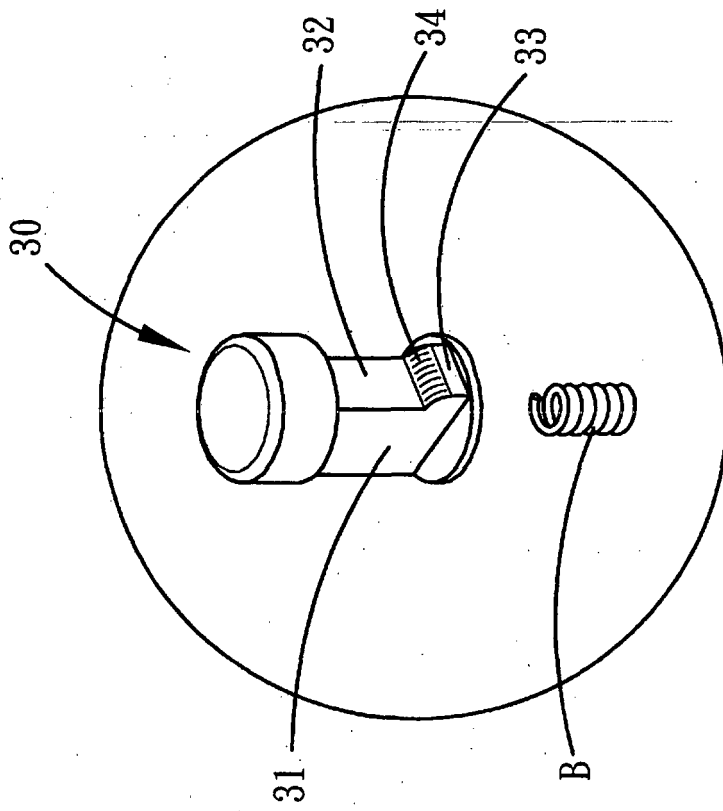
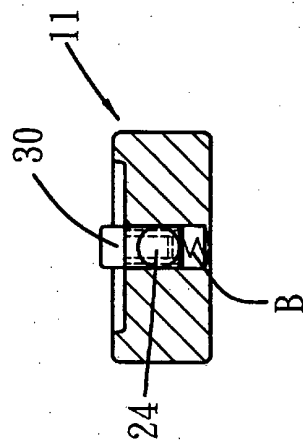
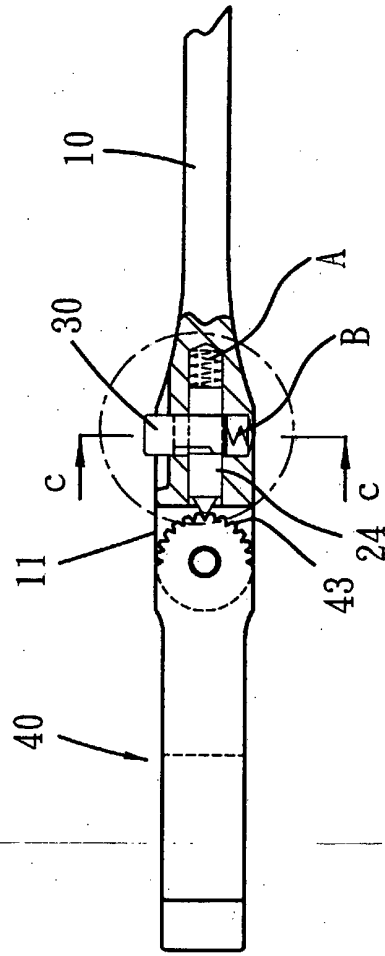
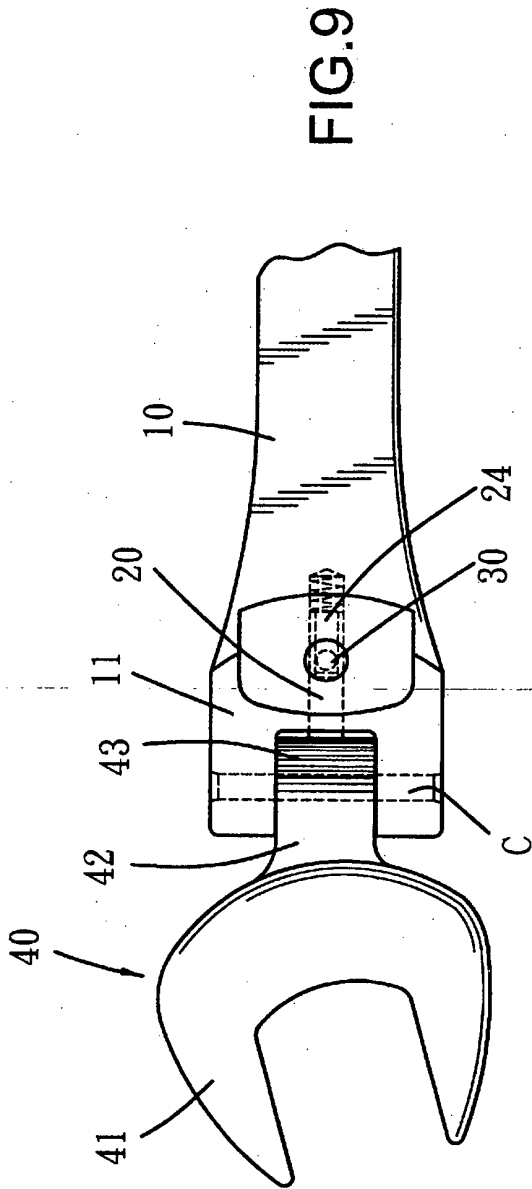

FIG. 8-1



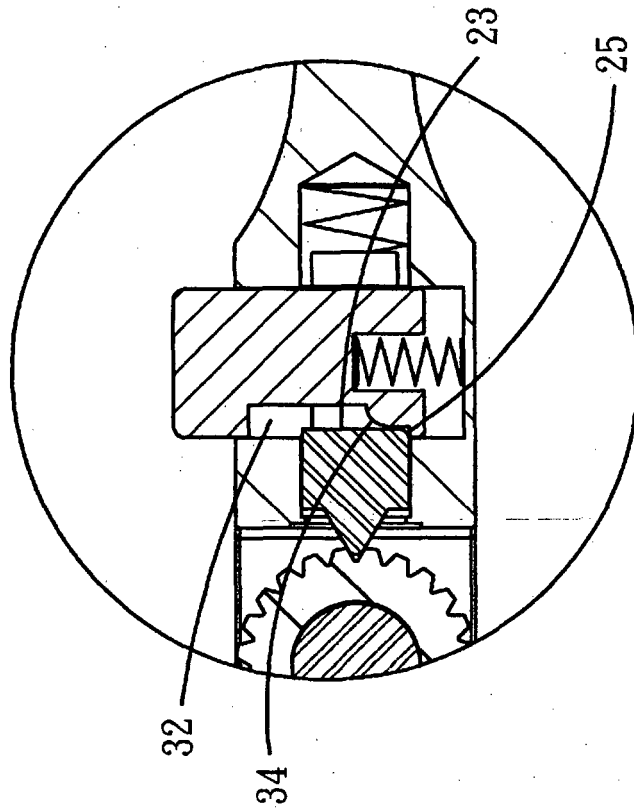
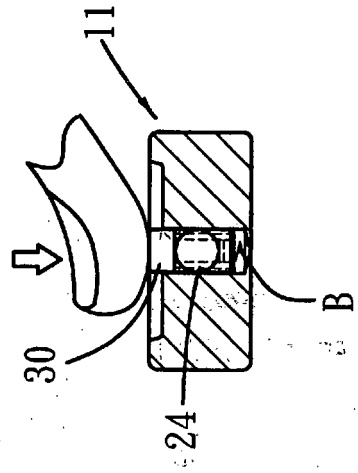
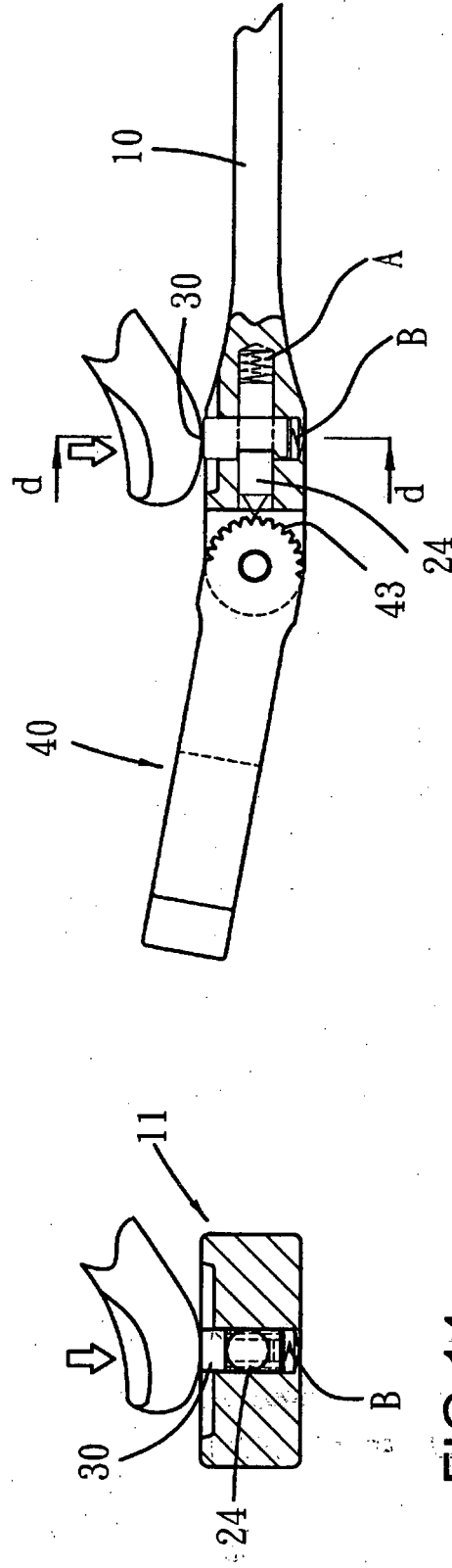
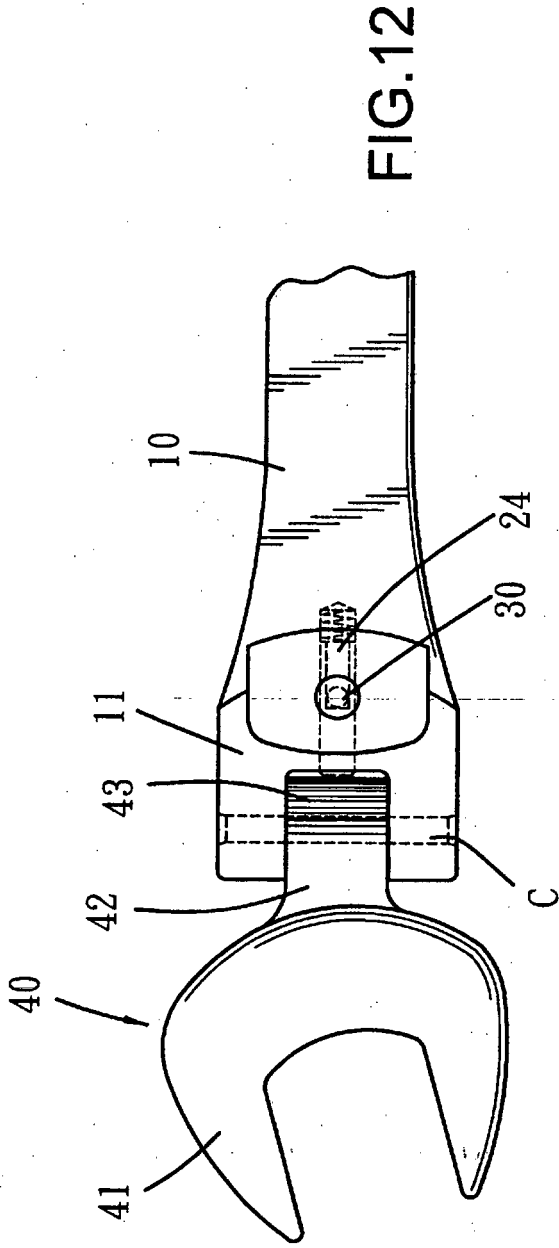
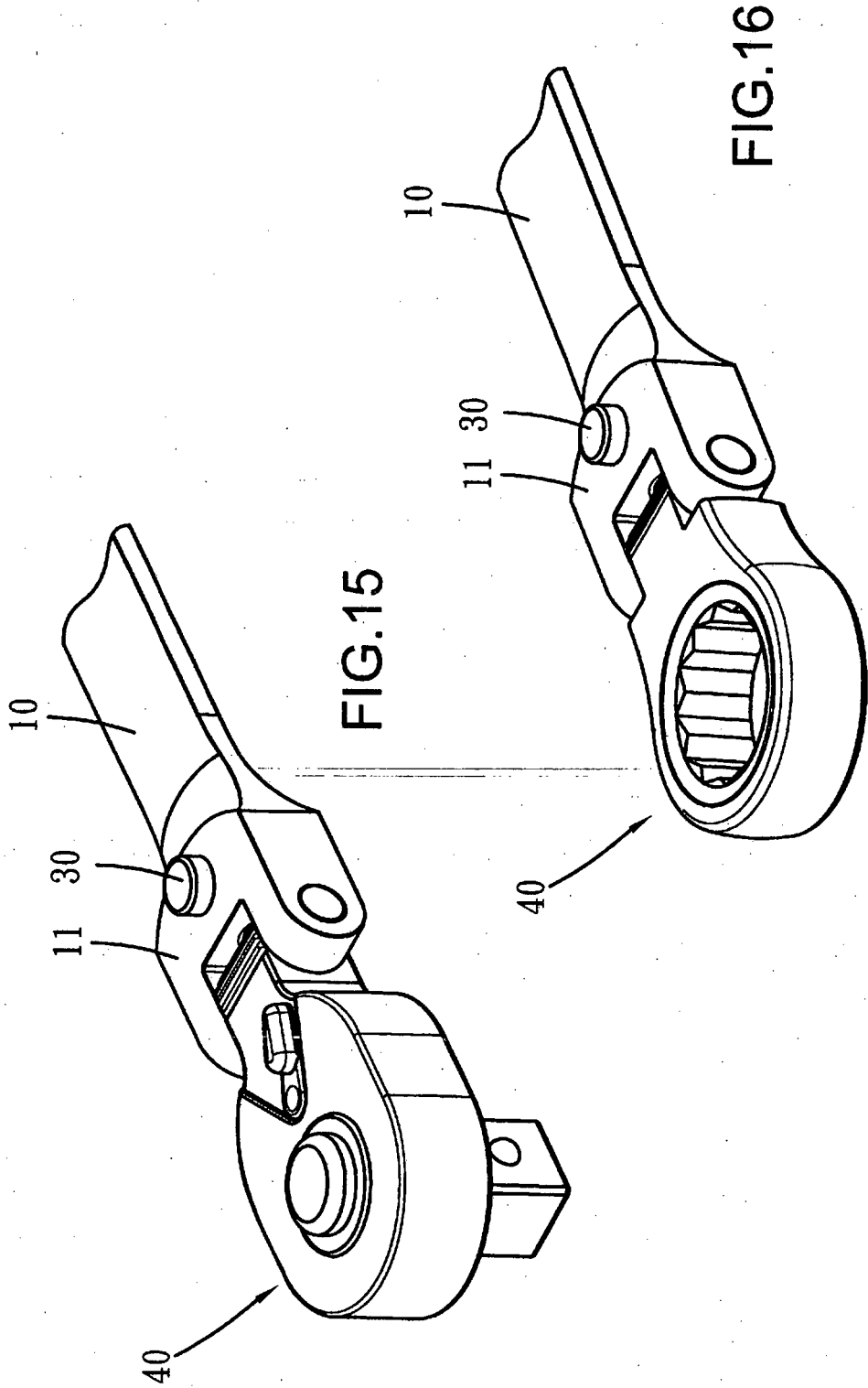

FIG.11





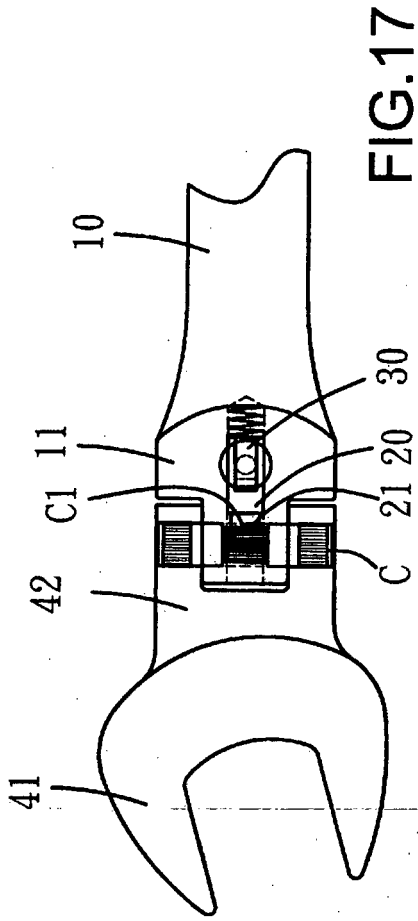

FIG. 17

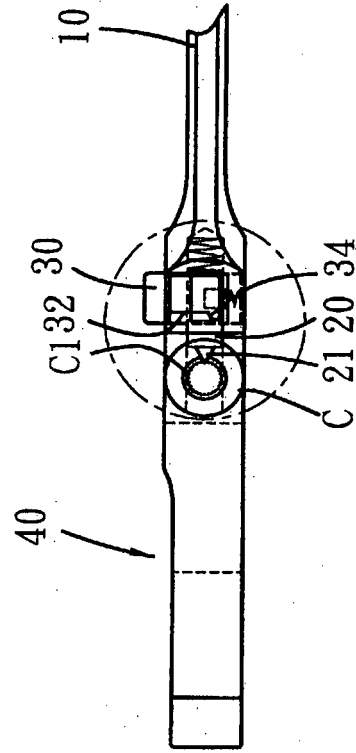

FIG. 18

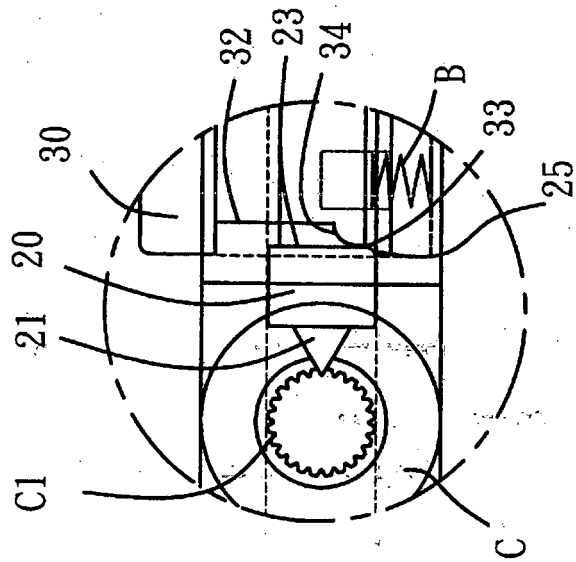

FIG. 19

**REFERENCES CITED IN THE DESCRIPTION**

*This list of references cited by the applicant is for the reader's convenience only. It does not form part of the European patent document. Even though great care has been taken in compiling the references, errors or omissions cannot be excluded and the EPO disclaims all liability in this regard.*

**Patent documents cited in the description**

- US 7131356 B [0002] [0004]
- US 7168346 B [0003]
- EP 1533081 A [0004]
- US 6857341 B [0004]
- US 6216317 B [0004]
- US 2004083861 A [0004]