

(19)



(11)

**EP 2 060 587 A1**

(12)

**EUROPEAN PATENT APPLICATION**

(43) Date of publication:  
**20.05.2009 Bulletin 2009/21**

(51) Int Cl.:  
**C08B 30/04 (2006.01)**

(21) Application number: **07120846.6**

(22) Date of filing: **16.11.2007**

(84) Designated Contracting States:  
**AT BE BG CH CY CZ DE DK EE ES FI FR GB GR  
 HU IE IS IT LI LT LU LV MC MT NL PL PT RO SE  
 SI SK TR**  
 Designated Extension States:  
**AL BA HR MK RS**

(72) Inventors:  
 • **Larsson, Jörgen  
 290 34 Fjälkinge (SE)**  
 • **Röge, Wolfgang  
 931 04 Sünching (DE)**  
 • **Suthumno, Nopanat  
 22140 Chataburi (TH)**

(71) Applicant: **Gösta Larssons Mekaniska Verkstad  
 AB  
 295 21 Bromölla (SE)**

(74) Representative: **Hjalmarsson, Magnus Axel  
 Awapatent AB,  
 Box 5117  
 200 71 Malmö (SE)**

(54) **Sieve cone**

(57) A centrifugal sieve (1) is used for separating starch granules from a starch containing raw material, containing starch granules, liquid and fibres. The sieve comprises a housing (2) with a rotatable separating drum (3) having minute sieving holes. These holes are provided in an inner drum surface for allowing the starch gran-

ules and liquid to pass through while retaining the fibres inside the drum. The sieving holes are extending all the way through a solid circumferential drum wall, thus creating on the outside of the drum wall a sieving hole configuration which is identical with a sieving hole configuration on the inside.

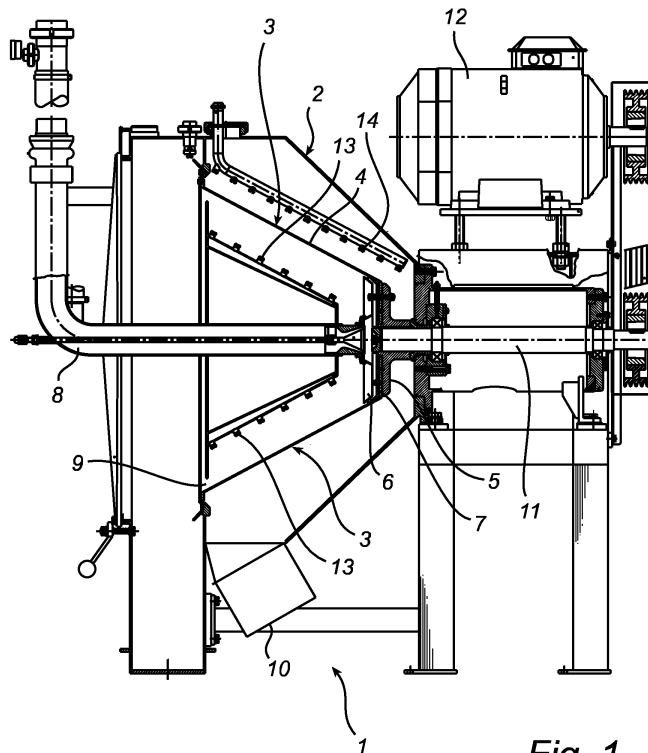

*Fig. 1*

**EP 2 060 587 A1**

## Description

### Technical Field of the Invention

**[0001]** Present invention relates to a centrifugal sieve for separating starch granules from a starch containing raw material, containing starch granules, liquid and fibres, which sieve comprises a housing with a rotatable separating drum having minute sieving holes, which are provided in an inner drum surface for allowing the starch granules and liquid to pass through while retaining the fibres inside the drum.

### Background Art

**[0002]** In the manufacturing of starch from different raw materials, such as roots like potatoes or manioc or from different grains like maize, wheat, rice or barley the starch granules in the cells of the raw material are to be extracted by disintegrating the raw material either by rasps or mills, sieving, washing and drying.

**[0003]** After disintegrating, the raw material has become a slurry containing fibres, starch granules and liquid. This slurry is conveyed to a centrifugal sieve, in which the starch granules and liquid are separated from the fibres.

**[0004]** The centrifugal sieves used up to now are essentially of the type shown in GB 778 507. In this type of sieve the starch slurry is fed to the top of a coarsely perforated, conical or cylindrical drum, the inside of which is covered with a screening plate insert. While the drum is rotating and the starch slurry is fed to the drum, water is sprayed on the inner drum wall via nozzles for washing out the starch. The starch granules are passing through the sieve whereas the fibres are sliding down the screening plate insert to be collected and discharged at an outlet below the drum.

**[0005]** The screening plate inserts can be a metal foil, screen cloth or gauze. These inserts are very thin and delicate; they have a thickness of 0,1 - 0,3 mm with a mesh size of 0,1-0,25 mm. As a screening insert wears down at operation it requires frequent repair or replacement, which is a time and labour demanding operation and includes removing of the conical drum from the centrifugal sieve, repairing or removing of the sieving insert, cleaning of the inner surface of the drum and applying of glue for fastening a new insert. One insert comprises several segments, which are fastened overlappingly one at a time. It is vital that the segments are sealingly attached to each other and to the drum. The exchanging operation greatly reduces the capacity of the centrifugal sieve. Further, this type of centrifugal sieves can only work at a limited rotational speed as the insert will loosen or crack at higher velocities.

### Summary of Invention

**[0006]** The object of the invention is to provide a cen-

trifugal sieve with improved capacity, higher reliability, less maintenance requirement and longer lifetime.

**[0007]** This object is achieved by means of a centrifugal sieve for separating starch granules from a starch containing raw material, containing starch granules, liquid and fibres, which sieve comprises a housing with a rotatable separating drum having minute sieving holes, which are provided in an inner drum surface for allowing the starch granules and liquid to pass through while retaining the fibres inside the drum, and is characterized in that the sieving holes are extending all the way through a solid circumferential drum wall thus creating on the outside of the drum wall a sieving hole configuration which is identical with a sieving hole configuration on the inside.

In this way a sieving insert and a supporting cage are integrally formed, which solves the above mentioned problems.

**[0008]** Each sieving hole has diameter of less than ca. 0,25 mm, preferably 0,1-0,25 mm, and is for exact and repeatable production drilled in the drum wall by means of electron beam drilling.

**[0009]** For prevention of clogging of the sieving holes each sieving hole is preferably conical, with increasing area towards the outer surface of the drum.

### Brief Description of the Drawings

**[0010]** By way of an example a preferred embodiment of the invention will be described with reference to the accompanying drawing.

**[0011]** Fig 1 is a cross section of a centrifugal sieve according the invention.

### Detailed Description of Preferred Embodiment of the Invention

**[0012]** A centrifugal sieve 1 shown in fig 1 is used for separating starch granules from a starch containing raw material in form of a slurry and comprises a housing 2 with a rotatable separating chamber or drum 3. The separating chamber is a truncated cone 4 provided with minute sieving holes. An end plate 5 is covering its smaller diameter opening.

**[0013]** For rotating the separating chamber 3, a rotating shaft 11, driven by a motor 12, is attached to the end plate 5, concentric with the axis of the cone.

**[0014]** The cone 4 has a slurry inlet 7 at the end plate 5 at the top of the cone. A distribution plate 6 is arranged in parallel with and adjacent to the end plate 5 inside the cone. A conduit 8 for feeding the slurry is passing through the larger diameter opening of the cone and ending at the inlet 7 between the end plate 5 and the distribution plate 6. In this way the fed slurry is distributed over the whole circular area at the top of the cone.

**[0015]** Inside the cone there is a set of nozzles 13 for spraying water at the inner cone wall, washing starch granules off the fibres and preventing material from clogging in the sieving holes. There is a set of nozzles 14 too

on the outside of the cone for rinsing the outer cone wall.

**[0016]** The larger diameter opening of the cone forms an outlet 9 for a fibre containing part of the slurry. An outlet 10 for a starch granule containing part of the slurry, having passed the sieving holes, is provided in the housing 2.

**[0017]** In the prior art centrifugal sieves, the drum acts as a supporting cage for the sieving insert. As such it has holes with a diameter of ca 10 mm with a wall thickness of ca 2 mm. The sieving insert has a thickness of ca 0,1 mm with sieving holes in form of slots with a width of 0,1 - 0,25 mm and a length of 1 mm. The size of the holes in the supporting cage in the known centrifugal sieves must be dimensioned carefully since on one hand it is necessary to have as large open area as possible for not blocking the material passing through the sieving holes. On the other hand if the holes are too large the supporting cage will not have the necessary supporting function for the sieving insert. The supporting cage inevitably lessens the sieving capacity of the sieve no matter the size of the holes in this cage.

**[0018]** The truncated cone 4 in the centrifugal sieve according the invention has a thickness of ca 2-3 mm and acts as both a supporting cage and a sieving insert.

**[0019]** The truncated cone 4 has an inner surface and an outer surface, wherein the inner surface and the outer surface have the same sieving hole configuration. The sieving holes are through bores directly made in the solid cone wall. The sieving holes have a diameter of 0,1 - 0,25 mm allowing the starch granules and liquid to pass through while retaining the fibers in the interior of the cone.

**[0020]** The cone has approximately 510 sieving holes per square centimeter

**[0021]** The sieving holes are conical, with increasing hole area towards the outer surface of the drum. This hole form will prevent material from blocking the holes.

**[0022]** The sieving holes are suitably perforated by electron beam drilling.

**[0023]** The above described centrifugal sieve is one example of a centrifugal sieve according the invention. The skilled man will realize that other embodiments are possible within the scope of the claims.

wall, thus creating on the outside of the drum wall a sieving hole configuration which is identical with a sieving hole configuration on the inside.

- 5 2. Centrifugal sieve according to claim 1, wherein each sieving hole has a diameter of less than ca. 0,25 mm.
3. Centrifugal sieve according to claim 1, wherein the sieving holes are drilled in the drum wall by means of electron beam drilling.
- 10 4. Centrifugal sieve according to claim 1, wherein each sieving hole is conical, with increasing area towards the outer surface of the drum.
- 15 5. Centrifugal sieve according to claim 1, wherein the sieving drum has a thickness of 1,5-3 mm.
- 20
- 25
- 30
- 35
- 40
- 45

## Claims

1. Centrifugal sieve for separating starch granules and liquid from a starch containing raw material, containing starch granules, liquid and fibres, which sieve comprises

a housing (2) with a rotatable separating drum (3) having minute sieving holes, which are provided in an inner drum surface for allowing the starch granules and liquid to pass through while retaining the fibres inside the drum (3),

**characterized in that** the sieving holes are extending all the way through a solid circumferential drum

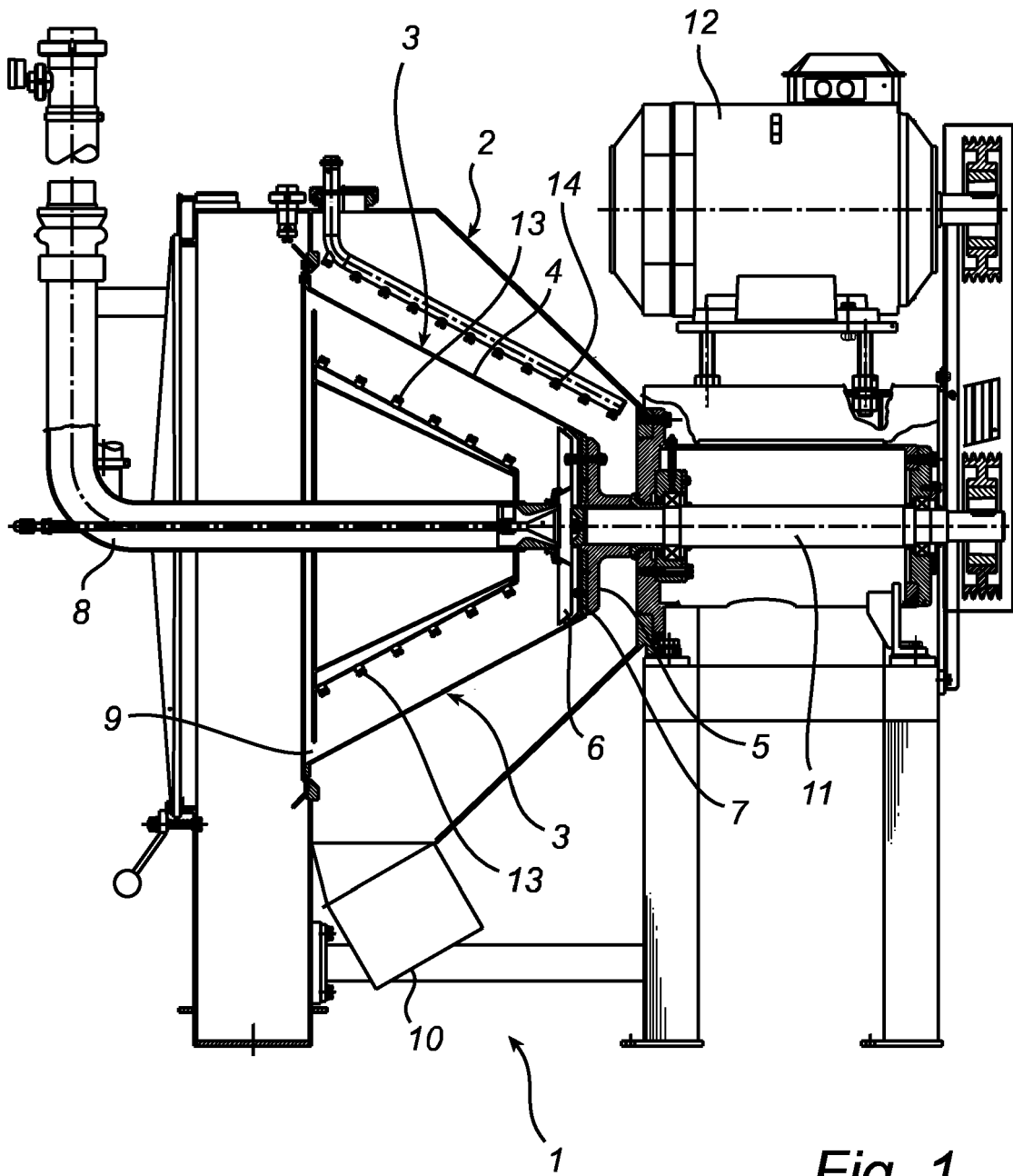

Fig. 1



DOCUMENTS CONSIDERED TO BE RELEVANT			
Category	Citation of document with indication, where appropriate, of relevant passages	Relevant to claim	CLASSIFICATION OF THE APPLICATION (IPC)
Y	DE 963 590 C (STARCO SA MASCHINEN U APPBAU G) 9 May 1957 (1957-05-09) * figures * * page 2, line 12 - page 3, line 9 * * claims *	1-5	INV. C08B30/04
Y	GB 1 101 802 A (WESTERN STATES MACHINE CO) 31 January 1968 (1968-01-31) * page 1, line 42 - page 3, line 71 * * figure 1 *	1-5	
Y	GB 1 124 713 A (HEIN LEHMANN AG) 21 August 1968 (1968-08-21) * page 1, lines 9-18 * * page 1, line 46 - page 2, line 31 *	1-5	
A	DE 928 160 C (LARSSON GOESTA) 26 May 1955 (1955-05-26) * the whole document *	1-5	
A	"Product roundup" FILTRATION AND SEPARATION, CROYDON, GB, vol. 43, no. 8, October 2006 (2006-10), page 11, XP005695335 ISSN: 0015-1882 * last paragraph *	4	
A	US 4 171 384 A (CHWALEK VINCENT P [US] ET AL) 16 October 1979 (1979-10-16) * column 3, lines 44-52 *	2	
The present search report has been drawn up for all claims			
Place of search The Hague		Date of completion of the search 22 April 2008	Examiner Hartlieb, Ariane
<p>CATEGORY OF CITED DOCUMENTS</p> <p>X : particularly relevant if taken alone                      Y : particularly relevant if combined with another document of the same category                      A : technological background                      O : non-written disclosure                      P : intermediate document</p> <p>T : theory or principle underlying the invention                      E : earlier patent document, but published on, or after the filing date                      D : document cited in the application                      L : document cited for other reasons</p> <p>&amp; : member of the same patent family, corresponding document</p>			

1  
EPO FORM 1503 03.02 (P04C01)

**ANNEX TO THE EUROPEAN SEARCH REPORT  
ON EUROPEAN PATENT APPLICATION NO.**

EP 07 12 0846

This annex lists the patent family members relating to the patent documents cited in the above-mentioned European search report. The members are as contained in the European Patent Office EDP file on  
The European Patent Office is in no way liable for these particulars which are merely given for the purpose of information.

22-04-2008

Patent document cited in search report		Publication date	Patent family member(s)	Publication date
DE 963590	C	09-05-1957	NONE	
-----				
GB 1101802	A	31-01-1968	BE 671655 A	14-02-1966
			DE 1482754 B1	20-08-1970
			NL 6514084 A	02-05-1966
			US 3302794 A	07-02-1967
-----				
GB 1124713	A	21-08-1968	FR 1516281 A	08-03-1968
-----				
DE 928160	C	26-05-1955	NONE	
-----				
US 4171384	A	16-10-1979	AU 522202 B2	20-05-1982
			AU 4616379 A	15-11-1979
			BE 876125 A1	03-09-1979
			CA 1117806 A1	09-02-1982
			IN 149685 A1	13-03-1982
			JP 1401795 C	28-09-1987
			JP 55009795 A	23-01-1980
			JP 62007814 B	19-02-1987
			KR 8300556 A	12-03-1983
			MX 5612 E	08-11-1983
-----				

**REFERENCES CITED IN THE DESCRIPTION**

*This list of references cited by the applicant is for the reader's convenience only. It does not form part of the European patent document. Even though great care has been taken in compiling the references, errors or omissions cannot be excluded and the EPO disclaims all liability in this regard.*

**Patent documents cited in the description**

- GB 778507 A [0004]