

(19)



(11)

EP 2 072 413 A3

(12)

EUROPEAN PATENT APPLICATION

(88) Date of publication A3:
26.08.2009 Bulletin 2009/35

(51) Int Cl.:
B65D 21/06 (2006.01) B65D 8/14 (2006.01)

(43) Date of publication A2:
24.06.2009 Bulletin 2009/26

(21) Application number: **08172185.4**

(22) Date of filing: **18.12.2008**

(84) Designated Contracting States:
AT BE BG CH CY CZ DE DK EE ES FI FR GB GR HR HU IE IS IT LI LT LU LV MC MT NL NO PL PT RO SE SI SK TR
Designated Extension States:
AL BA MK RS

(72) Inventor: **Apps, William**
Alpharetta, GA 30022 (US)

(74) Representative: **Lamb, Richard Andrew**
Urquhart-Dykes & Lord LLP
New Priestgate House
57 Priestgate
Peterborough
Cambridgeshire PE1 1JX (GB)

(30) Priority: **21.12.2007 US 16236 P**

(71) Applicant: **Rehrig Pacific Company**
Los Angeles, CA 90058 (US)

(54) **Collapsible container**

(57) A collapsible container (10) includes a plurality of walls (18,14) collapsible onto the base (12). At least one wall (18) has a support (20) pivotally mounted below a lip (25) formed on an upper edge of the wall (18). The support (20) is pivotable between a deployed position

where it is partially supported on an adjacent wall (14) and a retracted position. A torsion member (58) biases the support (20) toward the deployed position. A latch (68) deploys the support (20) as the wall (18) is moved toward the upright position.

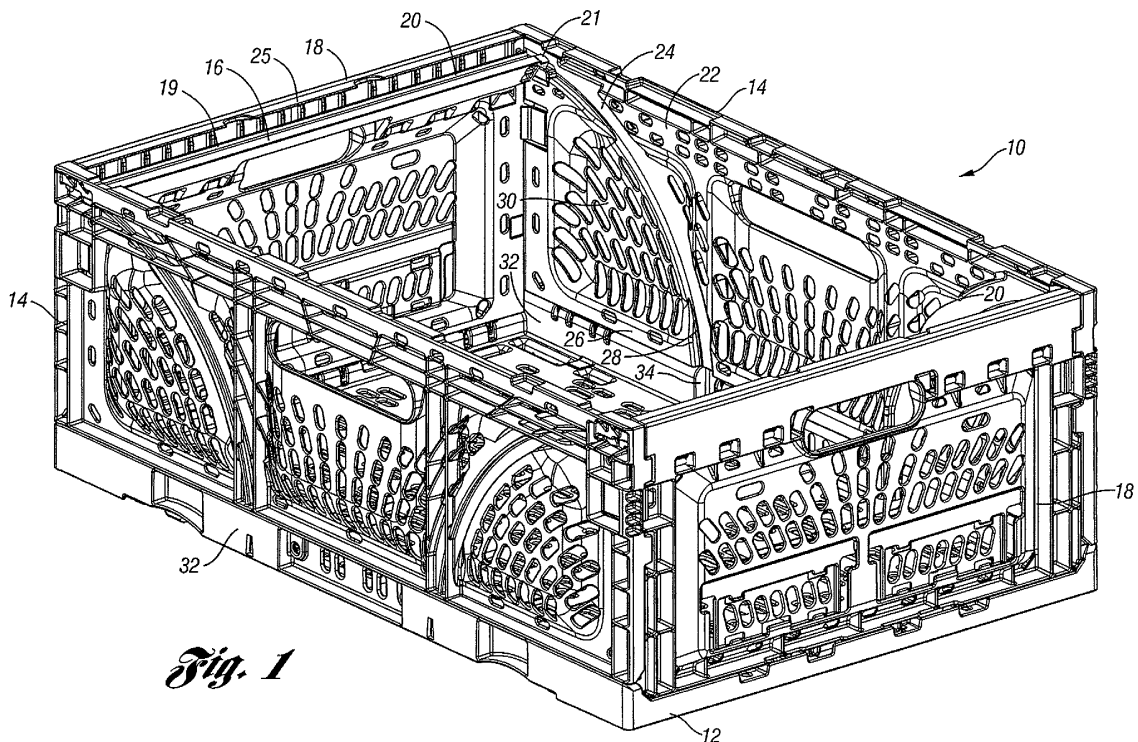

Fig. 1

EP 2 072 413 A3



EUROPEAN SEARCH REPORT

Application Number
EP 08 17 2185

DOCUMENTS CONSIDERED TO BE RELEVANT			
Category	Citation of document with indication, where appropriate, of relevant passages	Relevant to claim	CLASSIFICATION OF THE APPLICATION (IPC)
Y	US 2007/095842 A1 (APPS WILLIAM P [US]) 3 May 2007 (2007-05-03) * the whole document * -----	1-5,9,10	INV. B65D21/06 B65D8/14
Y	GB 2 333 285 A (LIMPAC MOULDINGS LTD [GB]) 21 July 1999 (1999-07-21) * page 7, lines 8-17; figures 1,4b * -----	1-5,9,10	
A	US 2003/116564 A1 (OVERHOLT TRENTON M [US] ET AL) 26 June 2003 (2003-06-26) * paragraph [0039]; figure 4 * -----	6-8, 11-13	
The present search report has been drawn up for all claims			TECHNICAL FIELDS SEARCHED (IPC)
			B65D
Place of search		Date of completion of the search	Examiner
Munich		13 July 2009	Cazacu, Corneliu
CATEGORY OF CITED DOCUMENTS			
X : particularly relevant if taken alone Y : particularly relevant if combined with another document of the same category A : technological background O : non-written disclosure P : intermediate document		T : theory or principle underlying the invention E : earlier patent document, but published on, or after the filing date D : document cited in the application L : document cited for other reasons & : member of the same patent family, corresponding document	

3
EPO FORM 1503 03.02 (P04C01)



Application Number

EP 08 17 2185

CLAIMS INCURRING FEES

The present European patent application comprised at the time of filing claims for which payment was due.

- Only part of the claims have been paid within the prescribed time limit. The present European search report has been drawn up for those claims for which no payment was due and for those claims for which claims fees have been paid, namely claim(s):
- No claims fees have been paid within the prescribed time limit. The present European search report has been drawn up for those claims for which no payment was due.

LACK OF UNITY OF INVENTION

The Search Division considers that the present European patent application does not comply with the requirements of unity of invention and relates to several inventions or groups of inventions, namely:

see sheet B

- All further search fees have been paid within the fixed time limit. The present European search report has been drawn up for all claims.
- As all searchable claims could be searched without effort justifying an additional fee, the Search Division did not invite payment of any additional fee.
- Only part of the further search fees have been paid within the fixed time limit. The present European search report has been drawn up for those parts of the European patent application which relate to the inventions in respect of which search fees have been paid, namely claims:
- None of the further search fees have been paid within the fixed time limit. The present European search report has been drawn up for those parts of the European patent application which relate to the invention first mentioned in the claims, namely claims:
- The present supplementary European search report has been drawn up for those parts of the European patent application which relate to the invention first mentioned in the claims (Rule 164 (1) EPC).



**LACK OF UNITY OF INVENTION
SHEET B**

Application Number
EP 08 17 2185

The Search Division considers that the present European patent application does not comply with the requirements of unity of invention and relates to several inventions or groups of inventions, namely:

1. claims: 1-5, 9, 10

torsion member

2. claims: 6-8, 11-13

latch member

**ANNEX TO THE EUROPEAN SEARCH REPORT
ON EUROPEAN PATENT APPLICATION NO.**

EP 08 17 2185

This annex lists the patent family members relating to the patent documents cited in the above-mentioned European search report. The members are as contained in the European Patent Office EDP file on
The European Patent Office is in no way liable for these particulars which are merely given for the purpose of information.

13-07-2009

Patent document cited in search report	Publication date	Patent family member(s)	Publication date
US 2007095842 A1	03-05-2007	GB 2431921 A	09-05-2007
		GB 2446969 A	27-08-2008
		GB 2452645 A	11-03-2009
		GB 2452646 A	11-03-2009
		GB 2452647 A	11-03-2009
		US 2007194023 A1	23-08-2007

GB 2333285 A	21-07-1999	NONE	

US 2003116564 A1	26-06-2003	AU 2002364096 A1	09-07-2003
		WO 03053799 A1	03-07-2003
		US 2006011627 A1	19-01-2006
