

(19)



(11)

EP 2 088 361 A1

(12)

EUROPEAN PATENT APPLICATION

(43) Date of publication:
12.08.2009 Bulletin 2009/33

(51) Int Cl.:
F21K 7/00 (2006.01)

(21) Application number: **08425068.7**

(22) Date of filing: **06.02.2008**

(84) Designated Contracting States:
**AT BE BG CH CY CZ DE DK EE ES FI FR GB GR
HR HU IE IS IT LI LT LU LV MC MT NL NO PL PT
RO SE SI SK TR**
Designated Extension States:
AL BA MK RS

(71) Applicant: **Luce in B & Giemme S.r.L.**
31050 Onigo di Pederobba (Treviso) (IT)

(72) Inventor: **Bonsembiante, Remo**
31049 Valdobbiadene - Treviso (IT)

(54) **Lighting device with LED and relating apparatus**

(57) In a lighting device (10) comprising support means (20), at least one lighting element (32) and a bulb (40) able to be mounted onto said support means (20) and to surround said at least one lighting element (32), the lighting element is a LED (Light Emitting Diode) (32) whereas the bulb (40) and the support means (20) are

provided with detachable coupling means (24,64), so as to make the bulb (40) manually removable with respect to the support means (20).

There is also a lighting apparatus (100) comprising stands (102,104,106) at the ends (102a,104a,106a) of which lighting devices (10) are mounted.

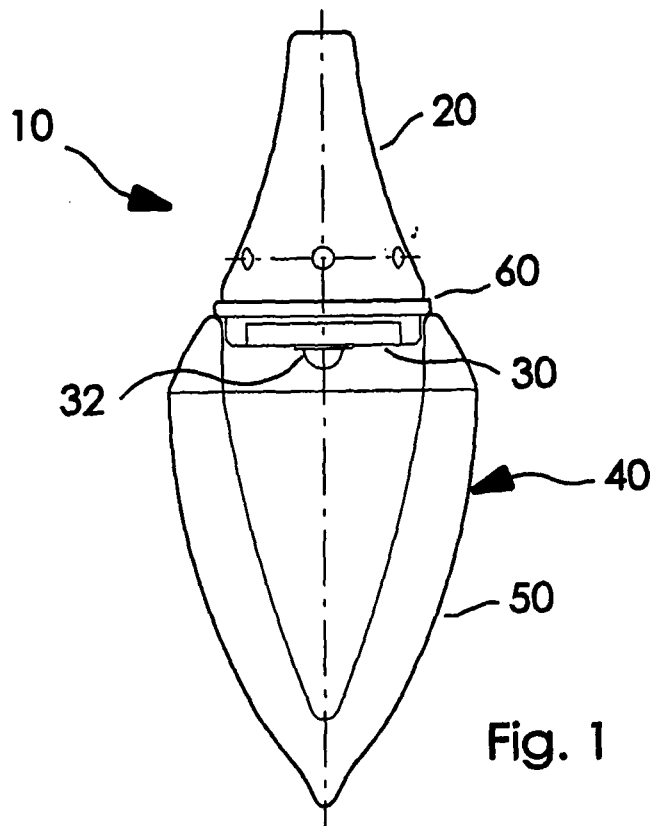

Fig. 1

EP 2 088 361 A1

Description

[0001] The present invention relates to a lighting device which comprises a support, a lighting element and a bulb which covers the lighting element.

[0002] The invention relates also to an apparatus wherein these devices are used, such as standard lamps, abat-jours or table lamps, chandeliers and appliques.

[0003] Prior art devices, as those initially indicated, consist in for example, standard incandescent bulbs which have a cylindrical support where outside there is a thread able to be screwed to a corresponding bulb socket which is mounted on the above-mentioned apparatus such as standard lamps, abat-jours, chandeliers and appliques. A lighting element, which consists of an electric filament, is fixed to a cylindrical support and it is surrounded by a bulb which is also fixed to the cylindrical support.

[0004] There exist other solutions to increase the efficiency of the incandescent bulbs.

[0005] One of these solutions makes use of the so-called LEDs (Light Emitting Diode) which are semiconductor devices able to generate light when they are electrically fed. Although, they have a reduced electric power of a few Watts, the light generated is strong.

[0006] So, LEDs are used simply as a direct source of light, for example at home where a plurality of LEDs directly light the environment.

[0007] However, this solution has some drawbacks since LEDs have a strong and direct light which is efficient only if we need localized lighting, but it is not suitable for a diffused lighting of an environment.

[0008] Other solutions have been devised which consist in surrounding LED with a transparent bulb.

[0009] This solution essentially consists in an incandescent bulb wherein the electric filament has been replaced by a LED, namely it comprises a support wherein a thread is made to be screwed into a corresponding bulb socket, a LED fixed on the support and a transparent bulb firmly secured to the support, so as to form a sole integral body which actually forms a light bulb.

[0010] This solution, although it takes advantage of the lighting efficiency of LEDs it has the same above-mentioned drawbacks, that is, it generates a strong and direct light not suitable to light an environment.

[0011] Moreover, in case the LED fails or in case any malfunctioning occurs, it is necessary to replace the entire light bulb with a new one, with the consequent costs.

[0012] It should also be considered that sellers must necessarily have several new light bulbs at their disposal with consequent costs and storage space.

[0013] The aim of the invention is thus to generate a diffused lighting, thus allowing the lighting either of a room or an entire environment.

[0014] Another aim of the invention is to avoid the complete replacement of the light bulb in case of failures or malfunctionings with consequent savings, and also to avoid the production, warehouse storage and transport of new light bulbs, and the reduction of these costs.

[0015] These aims are reached by a device as initially described, i.e. a lighting device comprising support means, at least one lighting element, and a bulb able to be mounted onto said support means and to surround said at least one lighting element, characterized in that said lighting element consists of at least one LED (Light Emitting Diode) and that said bulb and said support means are provided with detachable coupling means, so as to make said bulb manually removable with respect to said support means.

[0016] In so doing, in case the LED fails it is no longer necessary to remove the entire lighting device and to replace it with a new one, but it is only sufficient to manually remove the bulb, to replace the broken LED with a new one and to mount the bulb again onto the support means. Even in case of any malfunctioning of the device, it is sufficient to remove the bulb, to do repairs and, finally, to re-mount the bulb in the original position.

[0017] The replacement of the LED or the repair of the device is an extremely fast and simple operation. In case of failure of the LED, it is only sufficient to have a spare LED.

[0018] Consequently, there is a saving both for the purchaser because it is sufficient to simply buy the replacing LED, and for the manufacturer because it is sufficient to produce, warehouse and transport only simple LEDs.

[0019] In particular, said detachable coupling means consists of a thread made on said support means and a corresponding thread made on said bulb, so as to form a screw coupling, so that it is possible to screw said bulb onto said support means.

[0020] In order to remove the bulb, it is sufficient to unscrew the bulb from the support means which is a simple and quick operation.

[0021] The bulb is preferably semitransparent or translucent in order to generate a diffused lighting suitable for the lighting of an environment.

[0022] The invention also relates to a lighting apparatus comprising at least one stand having a first and a second end, in said second end a lighting device according to the invention is mounted.

[0023] The first end of said stand is fixed on a base suitable to be laid on the floor, on a table or on the wall, so as to form respectively a standard lamp, an abat-jour or an applique.

[0024] Otherwise, the first end of said at least one stand is fixed to a column, so as to form a chandelier.

[0025] The lighting device of the invention may be used in different ways, so as to form different kinds of lighting apparatus, such as standard lamps, abat-jours, appliques and chandeliers.

[0026] These and other advantageous characteristics of the invention will be more evident from the following detailed description of an embodiment made only for an illustrative and not limitative purpose with reference to the subsequent drawings wherein:

- figure 1 is a front view of a device according to the

invention;

- figure 2 is a front view of a table lamp according to the invention;
- figures 3a,3b,3c,3d are top views of the different elements of the device of figure 1 represented in an exploded view;
- figures 4a,4b,4c,4d are front views of the different elements of the device of figure 1 represented in an exploded view.

[0027] In figures 1, and in particular in figures 3a,3b, 3c,3d and 4a,4b,4c,4e, a lighting device is wholly indicated with reference 10 which comprises a support 20, a radiant plate 30 with a LED 32 and a bulb 40.

[0028] The support 20 has essentially the shape of a hollow truncated pyramid delimited by a first end 20a defining a small base and a second end 20b defining a large base. Both the first end 20a and the second end 20b are opened.

[0029] A circular seat 22 is made on the second end 20b of the support 20 in order to house the radiant plate 30, as also represented in figure 1.

[0030] Moreover, a thread 24 is made on the outer surface of the second end 20b, for example a thread of Edison type, the function of which will be described in the following.

[0031] The radiant plate 30 has an essentially circular shape with dimensions lesser than those of the circular seat 22 of the support 20, so that it can be housed inside the seat 22.

[0032] The LED 32 is mounted in the center of the radiant plate 30.

[0033] The LED may be of different powers according to the required light intensity. For example, it may be of 4W electric power, sufficient to light even an environment of a large dimension. Therefore, the radiant plate 30 has the function to dissipate the concentrated heat generated by the LED and for this reason, along its circular profile, it has tabs which facilitate the cooling.

[0034] Electric wires, which are not represented in figures, are connected to the LED 32 for the feeding and come out from the first end 20a of the support 20.

[0035] The bulb 40 comprises, in its turn, an ampoule 50 and a ring nut 60.

[0036] The ampoule 50 is preferably made of glass and it has a closed teardrop-shaped form with a circular opening 52 at its first end 50a opposite to a second end 50b ended with a point.

[0037] The ring nut 60 is inserted in the circular opening 52 and it is fixed for example by glueing or adhesive means.

[0038] The ring nut 60 has an inner circular opening 52 wherein a thread 64 corresponding to the thread 24 of the support 20 is made, so as to screw the ring nut 60 and the bulb 40 on the support 20.

[0039] The thread 64 made on the ring nut 60 and the corresponding thread 24 made on the support 20, thus form a screw coupling.

[0040] Once the ring nut 60 is fixed to the ampoule 50, so as to form the bulb 40, the assembly and the disassembly of the device 10 is very simple.

[0041] In fact, for the assembly it is sufficient to insert the radiant plate 30 with the LED 32 inside the circular seat 22 of the support 20 and have the electric supply wires of the LED come out from the first end 20a of the support 20, and manually screw the bulb 40 onto the support 20.

[0042] The disassembly occurs inversely, by unscrewing the bulb 40 from the support 20.

[0043] It is evident that in case of failure of the LED 32 or when any malfunctioning of the device 10 occurs, it is sufficient to unscrew the bulb 40, replace the broken LED or do the required repairs and, finally, screw the bulb 40 again.

[0044] The bulb 40 is semitransparent or translucent so that the strong and direct light of the LED 32 is diffused, creating a diffused brightness able to light an environment.

[0045] In this way it is possible to take advantage of the power and the lighting efficiency of LEDs which otherwise would be impossible due to the strong and direct light radiated by it.

[0046] The bulb 40 may be white thus obtaining a white light, or it can be coloured and according to the colour of the bulb a light with different colours and shades can be obtained which is undoubtedly more warm.

[0047] As mentioned above, the invention relates also to different lighting apparatus which is possible to construct with the lighting device 10, such as abat-jours or table lamps, standard lamps, appliques and chandeliers.

[0048] A table lamp 100 is illustrated as an example in figure 3.

[0049] The table lamp 100 comprises three stands 102,104,106: stands 102,104,106 have a first end 102a, 104a,106a fixed to a base 110 suitable to be laid on a table and a second end 102b,104b,106b on each end of which a support 20 is mounted and, then, the device 10 previously described.

[0050] Similarly, it is possible to make standard lamps or appliques. In this case there are stands which at one end are fixed to a base suitable to be laid respectively on the ground or be fixed on a wall, whereas on the other end lighting devices 10 are mounted.

[0051] Even chandeliers can be made by simply fixing stands on a column and mounting the lighting devices 10 on the free end of the stands.

[0052] It is evident that any functionally or conceptually equivalent change or variation falls inside the scope of the present invention.

[0053] For example, the bulb 40 could not be provided with the ring nut 60, and the thread 64 could be made directly on the ampoule 50, thus eliminating a component, i.e. the ring nut 60, and in this case the ampoule 50 is screwed directly on the support 20.

[0054] Moreover, instead of only one LED mounted on the radiant plate 30, it is possible to mount two or more

LEDs on the same plate.

[0055] It is possible to make lighting apparatus with a greater number of stands, for example 4, 8 or even 12 stands.

[0056] As an alternative to the screw coupling composed of the thread 64 made on the ring nut 60 and the corresponding thread 24 made on the support 20, it is possible to use a bayonet coupling in which projections are made on the ring nut 60 and corresponding recesses are made on the support 20 or, viceversa, on the ring nut 60 recesses are made and corresponding projections are made on the support 20, to make the bulb 40 insertable in the support 20.

Claims

1. Lighting device (10) comprising support means (20), at least one lighting element (32) and a bulb (40) able to be mounted onto said support means (20) and to surround said at least one lighting element (32), **characterized in that** said lighting element consists of at least one LED (Light Emitting Diode) (32) and that said bulb (40) and said support means (20) are provided with detachable coupling means (24,64), so as to make said bulb (40) manually removable with respect to said support means (20).
2. Lighting device according to claim 1, **characterized in that** said bulb (40) has an opening (52) and said detachable coupling means (24,64) are made on one side on said support means (20) and on the other side at the opening (52) of said bulb (40).
3. Lighting device according to claim 2, **characterized in that** said detachable coupling means consists of a thread (24) made on said support means (20) and a corresponding thread (64) made on said bulb (40), so as to form a screw coupling, to make possible the screwing of said bulb (40) onto said support means (20).
4. Lighting device according to claim 2, **characterized in that** said detachable coupling means consists of projections and corresponding recesses made on said support means and said bulb, so as to form a bayonet coupling, to make said bulb insertable in said support means.
5. Lighting device according to any of the previous claims, **characterized in that** said bulb (40) is semi-transparent or translucent, so as to diffuse the strong and direct light of said at least one LED (32).
6. Lighting device according to claim 5, **characterized in that** said bulb (40) is coloured, so as to generate a coloured light.
7. Lighting device according to any of the previous claims, **characterized in that** said bulb (40) comprises an ampoule (50) and a ring nut (60) where said opening (52) is made and said detachable coupling means (24,64) are respectively made on said support means (20) and said ring nut (60).
8. Lighting device according to any of the previous claims, **characterized in that** said at least one LED (32) is mounted on a radiant plate (30) able to dissipate the heat.
9. Lighting device according to claim 8, **characterized in that** said radiant plate (30) is housed in a seat (22) made in said support means (20).
10. Lighting device according to claim 9, **characterized in that** said support means (20) have essentially the shape of a hollow truncated pyramid delimited by a first end (20a) defining a small base and a second end (20b) defining a large base, and at the second end (20b) is made said seat (22) for said radiant plate (30).
11. Lighting apparatus (100) comprising at least one stand (102) having a first end a second end (102a, 102b), in said second end (102b) a lighting device (10) according to any of the previous claims is mounted.
12. Lighting apparatus according to claim 11, **characterized in that** said support means (20) of said lighting device (10) are mounted on said second end (102b) of said at least one stand (102).
13. Lighting apparatus according to claim 10, **characterized in that** said first end (102a) of said at least one stand (102) is fixed on a base (110) able to be laid on a table, so as to form a table lamp or an abat-jour.
14. Lighting apparatus according to claim 12, **characterized in that** said first end of said at least one stand is fixed on a base able to be laid on the ground, so as to form a standard lamp.
15. Lighting apparatus according to claim 12, **characterized in that** said first end of said at least one stand is fixed on a column, so as to form a chandelier.
16. Lighting apparatus according to claim 12, **characterized in that** said first end of said stand is fixed on a base able to be fixed to a wall, so as to form an applique.
17. Lighting apparatus according to any of previous claims 11 to 16, **characterized in that** said at least one stand are two or more.

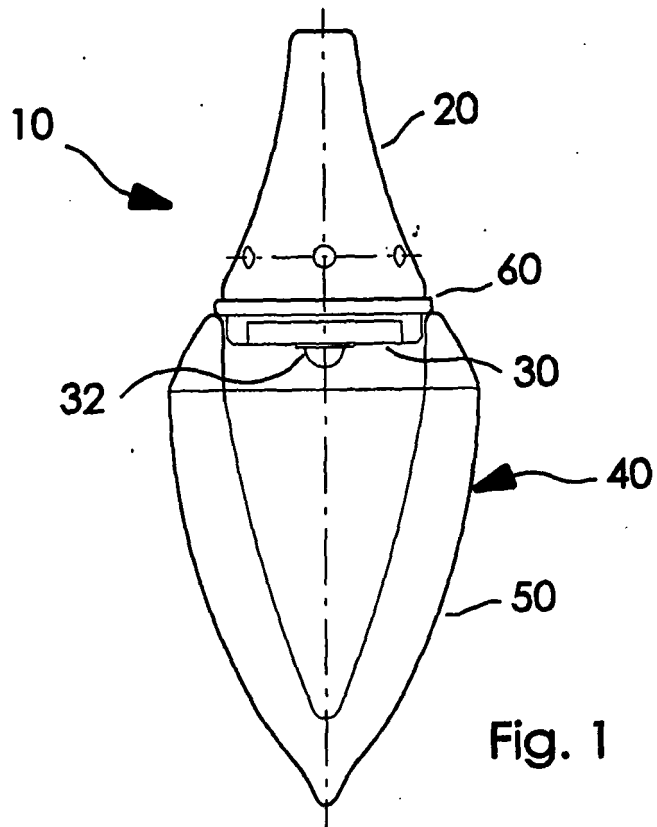

Fig. 1

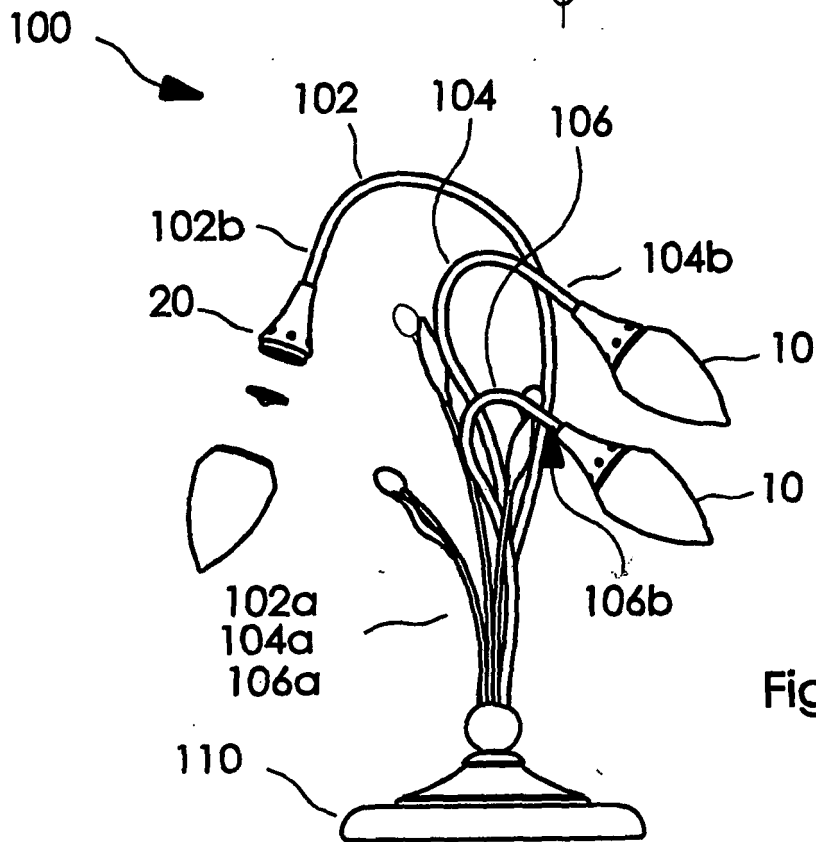
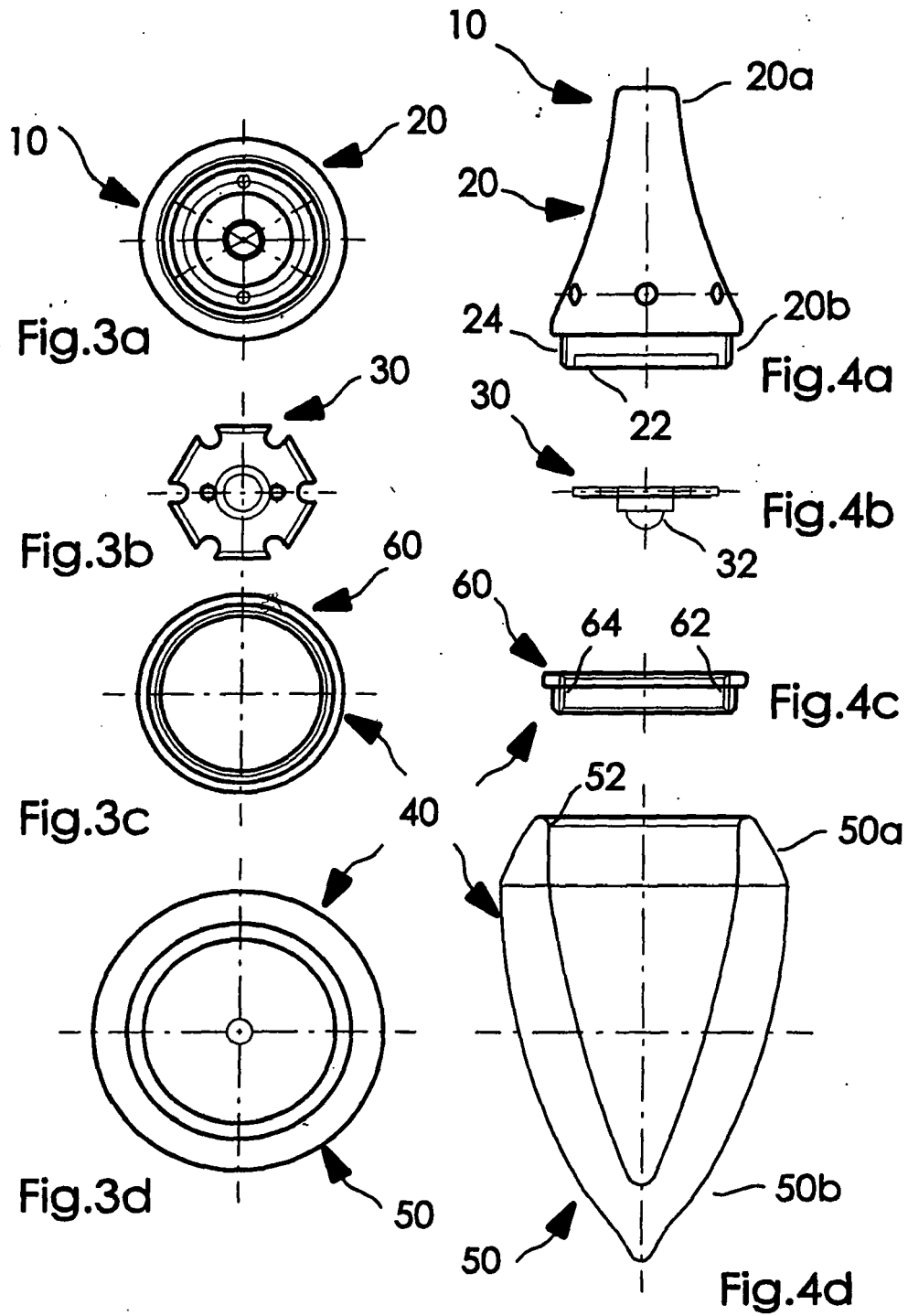

Fig. 2





DOCUMENTS CONSIDERED TO BE RELEVANT			
Category	Citation of document with indication, where appropriate, of relevant passages	Relevant to claim	CLASSIFICATION OF THE APPLICATION (IPC)
X	WO 2006/118457 A (GEMEX CONSULTANCY B V [NL]; ROOYMANS JOHANNES OTTO [NL]) 9 November 2006 (2006-11-09) * page 4, line 23 - page 5, line 5 * * page 6, line 26 - page 7, line 12 * * figures 2,3 *	1-8, 11-17	INV. F21K7/00
X	US 2005/243550 A1 (STEKELENBURG ALBERT [TW]) 3 November 2005 (2005-11-03) * the whole document *	1,2,4-6, 8-17	
			TECHNICAL FIELDS SEARCHED (IPC)
			F21K
The present search report has been drawn up for all claims			
Place of search		Date of completion of the search	Examiner
The Hague		20 May 2008	Amerongen, Wim
CATEGORY OF CITED DOCUMENTS			
X : particularly relevant if taken alone Y : particularly relevant if combined with another document of the same category A : technological background O : non-written disclosure P : intermediate document		T : theory or principle underlying the invention E : earlier patent document, but published on, or after the filing date D : document cited in the application L : document cited for other reasons & : member of the same patent family, corresponding document	

2
EPO FORM 1503 03.02 (P04C01)

**ANNEX TO THE EUROPEAN SEARCH REPORT
ON EUROPEAN PATENT APPLICATION NO.**

EP 08 42 5068

This annex lists the patent family members relating to the patent documents cited in the above-mentioned European search report. The members are as contained in the European Patent Office EDP file on
The European Patent Office is in no way liable for these particulars which are merely given for the purpose of information.

20-05-2008

Patent document cited in search report	Publication date	Patent family member(s)	Publication date
WO 2006118457 A	09-11-2006	EP 1869365 A1	26-12-2007
		KR 20070118171 A	13-12-2007
		NL 1028678 C2	03-10-2006

US 2005243550 A1	03-11-2005	NONE	

EPO FORM P0459

For more details about this annex : see Official Journal of the European Patent Office, No. 12/82