



(12) **EUROPEAN PATENT APPLICATION**

(43) Date of publication:  
**09.09.2009 Bulletin 2009/37**

(51) Int Cl.:  
**B27M 1/08<sup>(2006.01)</sup> B65G 65/00<sup>(2006.01)</sup>**

(21) Application number: **09154162.3**

(22) Date of filing: **02.03.2009**

(84) Designated Contracting States:  
**AT BE BG CH CY CZ DE DK EE ES FI FR GB GR HR HU IE IS IT LI LT LU LV MC MK MT NL NO PL PT RO SE SI SK TR**  
 Designated Extension States:  
**AL BA RS**

(71) Applicant: **BIESSE S.p.A.**  
**61100 Pesaro (IT)**

(72) Inventor: **Bernardi, Paolo**  
**47841 Cattolica (IT)**

(74) Representative: **Jorio, Paolo et al**  
**STUDIO TORTA**  
**Via Viotti 9**  
**10121 Torino (IT)**

(30) Priority: **03.03.2008 IT BO20080140**

(54) **Method and machine for machining wood components or the like**

(57) A method and machine for machining wood components (2) or the like, according to which each component (2) to be machined is fed to a feeding station (30, 33) by means of a movable carriage (41) having a plurality of resting planes (P3) for a plurality of components (2),

is transferred from the relevant resting plane (P3) to a gripping and conveying assembly (15, 25) by means of a lifting device (37) movable between the resting planes (P3) themselves, and is released by the gripping and conveying assembly (15, 25) to a clamping device (23) to be machined by means of an operating head (12).

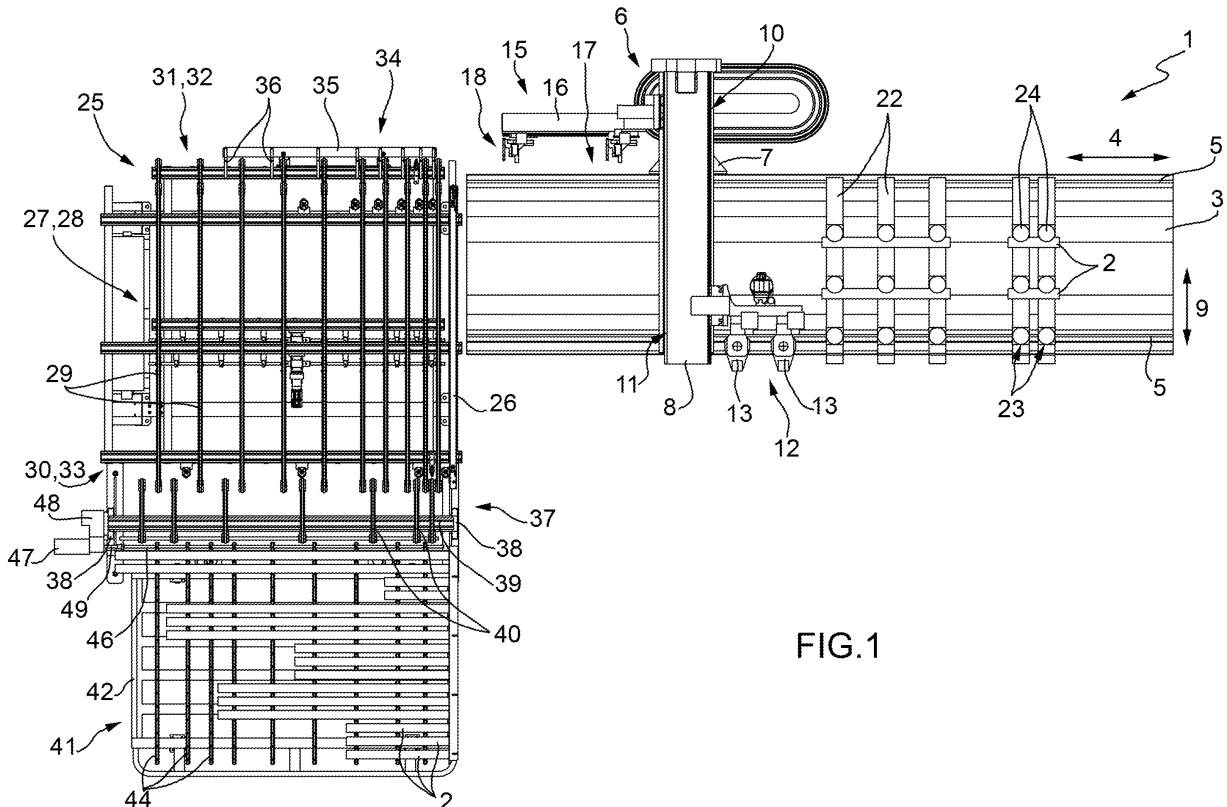

FIG.1

## Description

**[0001]** The present invention relates to a method for machining wood components or the like, specifically components for door and window frames.

**[0002]** In the field of machining door and window frame components, there are known machines of the type comprising an elongated base provided with two longitudinal guiding members, a plurality of crosspieces slidingly coupled to the longitudinal guiding members, at least one clamping vice mounted to each crosspiece for blocking the components to be machined, a crane movable along the base in a first direction, and an operating head movable along the crane in a second direction transversal to the first direction.

**[0003]** The crane is generally provided with a gripping and conveying assembly movable along the crane in the second direction and adapted to transfer the components to be machined and the newly machined components between the corresponding clamping vices and a feeding device for the components themselves.

**[0004]** Three types of feeding devices are normally used in the known machines of the above-described type.

**[0005]** According to a first type, the feeding device comprises a single belt conveyor, which extends in the second direction, and is motorized to intermittently feed the components to be machined from a loading station, at which the operator loads the components to be machined in sequence onto the belt conveyor, to a transfer station, where the gripping and conveying assembly picks the components to be machined from the belt conveyor and transfers them to the corresponding clamping vices. The newly machined components are released by the gripping and conveying assembly at the loading station, which is cleared each time by feeding the components to be machined.

**[0006]** According to another type, the feeding device comprises two reciprocally overlapping belt conveyors, one of which is used to transfer the components to be machined to the gripping and conveying assembly, and the other is used to receive the newly machined components from the gripping and conveying assembly itself.

**[0007]** According to a third type, the feeding device comprises two belt conveyors either reciprocally aligned in the second direction or arranged on opposite sides of the base in the first direction, one of which is used to transfer the components to be machined to the gripping and conveying assembly, and the other is used to receive the newly machined components from the gripping and conveying assembly itself.

**[0008]** Since the mentioned feeding devices should be relatively small-sized to allow their use in modern systems for machining door and window frame components, the known machines of the above-described type have some drawbacks, mostly deriving from the feeding devices being not able to handle large quantities of components, provide a relatively low production autonomy of such machines and imply the constant presence of per-

sonnel for loading and unloading the components to and from the feeding devices, respectively.

**[0009]** It is an object of the present invention to provide a method for machining wood components or the like which is free from the above-described drawbacks and which is simple and cost-effective to be implemented.

**[0010]** According to the present invention, there is provided a method for machining wood components or the like as claimed in the claims from 1 to 7.

**[0011]** The present invention further relates to a machine for machining wood components or the like, specifically components for door and window frames.

**[0012]** According to the present invention, there is provided a machine for machining wood components or the like as claimed in the claims from 8 to 16.

**[0013]** The present invention will now be described with reference to the accompanying drawings, which illustrate a non-limitative embodiment thereof, in which:

figure 1 is a schematic plan view of a preferred embodiment of the machine of the present invention; figure 2 is a schematic side view, with parts removed for clarity, of the machine in figure 1; figure 3 is a schematic perspective view of a detail of the machine in figures 1 and 2; and figure 4 is a schematic plan view of the detail in figure 3.

**[0014]** With reference to figures 1 and 2, numeral 1 indicates as a whole a machine for machining wood components 2 or the like for door and window frames comprising an elongated base 3, which extends in a horizontal direction 4, is substantially U-shaped, and has two longitudinal guiding side members 5 which are substantially parallel to the direction 4 itself.

**[0015]** Machine 1 further comprises a crane 6 comprising, in turn, a vertical upright 7, which is coupled in a known manner to the base 3 to perform rectilinear movements in direction 4, along the base 3 itself and under the bias of a known actuating device (not shown), and carries a crosspiece 8 connected to a free end thereof, which extends over the base 3 in a horizontal direction 9 which is transversal to the direction 4, and is laterally limited by two reciprocally opposite faces 10, 11 which are substantially orthogonal to the direction 4 itself.

**[0016]** The crane 6 supports an operating head 12 of known type, which is mounted to the face 10, is coupled in a known manner to the crosspiece 8 to perform, along the crosspiece 8 itself, rectilinear movements in the direction 9, and comprises, in this case, two electrospindles 13 fitted in a known manner on the head 12 to move in a vertical direction 14 orthogonal to directions 4 and 9.

**[0017]** Furthermore, the crane 6 supports a gripping and conveying assembly 15, comprising an arm 16, which protrudes from the face 11 of the crosspiece 8 in the direction 4, is coupled in a known manner to the crosspiece 8 to perform rectilinear movements in the direction 9, along the crosspiece 8 itself and under the bias of an

actuating device (known and not shown), and supports, in this case, two gripping and conveying devices 17, 18, which device 17 is fixed to the arm 16 in the direction 4 and which device 18 is coupled in a known manner to the arm 16 to perform rectilinear movements in the direction 4, along the arm 16 itself and under the bias of a known actuating device (not shown).

**[0018]** Each device 17, 18 comprises a lower jaw 19, which is substantially L-shaped and is movable in the direction 14 under the bias of an actuating device (known and not shown), and an upper jaw 20 movable between a clamping position and a releasing position of a component 2 under the bias of an actuator cylinder 21 fixed to the jaw 19.

**[0019]** Furthermore, machine 1 is provided with a plurality of crosspieces 22, which will be referred to as "worktops" hereinafter, extend between the longitudinal members 5 in the direction 9, and are slidably coupled to the longitudinal members 5 to be moved, either manually or by means of respective actuating devices (known and not shown) along the longitudinal members 5 themselves in the direction 4.

**[0020]** Worktops 22 support a plurality of clamping vices 23, the arrangement of which on the corresponding worktops 22 substantially depends on the size of components 2 to be machined and on the machining operations to be carried out on the components 2 themselves. Each clamping vice 23 comprises two jaws 24 (only one of which is shown in figure 1) movable between a clamping position and a releasing position of a component 2.

**[0021]** Machine 1 is further provided with a feeding assembly 25 connected to the gripping and conveying assembly 15 and comprising, in this case, a base 26, which is mounted at one end of base 3, extends in the direction 9, and supports two feeding devices 27, 28, which define two horizontal, reciprocally overlapping and parallel conveying planes P1, P2, and each comprise a respective plurality of motorized belt conveyors 29 parallel to one another and to the direction 9 itself.

**[0022]** Device 27 extends between an inlet station 30 and a transfer station 31 for the components 2 to be machined to the gripping and conveying assembly 15, while device 28 is adapted to feed the newly machined components 2 from an inlet station 32, protruding beyond the station 31 in the direction 9, to an outlet station 33, opposite to the station 31 and arranged at the station 30.

**[0023]** In this case, device 28 is associated with a lifting device 34 comprising a supporting beam 35 substantially parallel to the direction 4, and a plurality of arms 36, which protrude from beam 35 in the direction 9, and each extend between two reciprocally adjacent respective belt conveyors 29. Beam 35 is movable in the direction 14 between a raised position, in which the device 34 receives the newly machined component 2 from the gripping and conveying assembly 15, and a lowered position, in which the arms 36 are arranged underneath the plane P2 of the device 28 for releasing the component 2 on the plane P2 itself.

**[0024]** According to a variant (not shown), the lifting device 34 may be obviously eliminated and the newly machined components 2 may be directly released by the gripping and conveying assembly 15 onto the belt conveyors 29 of device 28.

**[0025]** As shown in figures 3 and 4, the inlet 30 and outlet 33 stations cooperate with a lifting device 37, which is arranged on the opposite side of the lifting device 34 with respect to the feeding assembly 25, and comprises two vertical fixed uprights 38 which are parallel to each other and to the direction 14, and a horizontal crosspiece 39 extending between the uprights 38 in the direction 4.

**[0026]** The crosspiece 39 is coupled in a known manner to the uprights 38 to perform rectilinear movements, along the uprights 38 themselves and under the bias of an actuating device (known and not shown) in the direction 14, and supports a plurality of motorized belt conveyors 40, which are parallel to one another and to the direction 9, are reciprocally coplanar, and each extending between two reciprocally adjacent respective belt conveyors 29.

**[0027]** Machine 1 is further provided with at least one feeding carriage 41, which is arranged, in use, in a working position facing the lifting device 37, has a length measured parallelly to the direction 4 which is substantially equal to a width of the feeding assembly 25 and lifting device 37 also measured parallelly to the direction 4, and comprises a frame 42 provided with feeding wheels 43, and a plurality of parallel, reciprocally overlapping horizontal resting planes P3.

**[0028]** Each plane P3 is defined by a plurality of reciprocally parallel belt conveyors 44, each of which extends in the direction 9, is mounted to the frame 42 to be arranged, when the carriage 41 is moved to its working position, between two reciprocally adjacent belt conveyors 40, and is looped about a pair of pulleys 45, one of which is fitted onto a supporting shaft 46, which is in common to the pulleys 45 of the other conveyors 44, and is idly mounted to the frame 42 to rotate about a longitudinal axis thereof parallel to the direction 4.

**[0029]** The shafts 46 are selectively and intermittently rotated about their longitudinal axes by means of an electric motor 47, which is mounted to a slide 48 movable along the uprights 38 in the direction 14, and has an outlet shaft 49 axially and pivotally mounted to be moved to and from an extracted connecting position of a shaft 46.

**[0030]** Each conveyor 44 is further provided with a plurality of pushing and conveying elements 50, which are uniformly distributed along the conveyor 44, and cooperate with corresponding elements 50 of the other conveyors 44 of the corresponding plane P3 to feed the corresponding components 2 in the direction 9.

**[0031]** In use, once the components 2 to be machined have been loaded on the planes P3 so as to clear a plane P3, the carriage 41 is moved by the personnel to its working position, the crosspiece 39 of the lifting device 37 is selectively moved between the planes P3 in the direction 14 to arrange the belt conveyors 40 in a position coplanar

with a plane P3, the slide 48 is moved in the direction 14 to allow the outlet shaft 49 of the motor 47 to be connected to the corresponding supporting shaft 46, and the motor 47 is actuated to transfer each time a component 2 to be machined from the corresponding plane P3 to the conveyors 40.

**[0032]** The component 2 to be machined is thus transferred by means of the conveyors 40 to the plane P1, is fed by the feeding device 27 to the transfer station 31, and is transferred by the gripping and conveying assembly 15 to the corresponding clamping vices 23 to be machined by the operating head 12.

**[0033]** Once the machining is finished, the newly machined component 2 is transferred by means of the gripping and conveying assembly 15 to the lifting device 34, is released by the lifting device 34 to the plane P2 at the inlet station 32, and is transferred by the feeding device 28 to the outlet station 33.

**[0034]** At this point, the newly machined component 2 is transferred to the belt conveyors 40 of lifting device 37, the crosspiece 39 is moved in the direction 14 to arrange the conveyors 40 in a position coplanar to the plane P3 which is free to accommodate each time the newly machined component 2, and the newly machined component 2 is transferred to the plane P3 itself.

**[0035]** Once all the components 2 on the carriage 41 have been machined, carriage 41 is moved from its working position and replaced with a new carriage 41 loaded with new components 2 to be machined.

**[0036]** Machine 1 has some advantages mainly deriving from the carriage 41 being relatively simple and cost-effective, being free from motors, being capable of stocking a relatively high number of components 2, ensuring a relatively high production autonomy to machine 1, and implying a relatively low presence of operating personnel.

**[0037]** According to some variants (not shown):

the feeding assembly 25 is eliminated and the components 2 are directly transferred between the gripping and conveying assembly 15 and the lifting device 37;

the feeding assembly 25 is eliminated, the components 2 to be machined are directly transferred from carriage 41 to the gripping and conveying assembly 15 by means of the lifting device 37, and the newly machined components 2 are directly transferred from the assembly 15 to a further carriage entirely similar to the carriage 41 either by means of the same device 37 or by means of a further lifting device entirely similar to the device 37 itself; and

the feeding assembly 25 is eliminated and replaced by two feeding assemblies, which have each a single resting plane, are arranged on opposite sides of the base 3 in the direction 4 or are reciprocally aligned in the direction 9, and cooperate each with a corresponding lifting device 37 and a corresponding carriage 41, and therefore are used one to feed the components 2 to be machined to the gripping and con-

veying assembly 15 and the other is used to receive the newly machined components 2 from the assembly 15 itself.

## Claims

1. A method for machining wood components (2) or the like, in particular components (2) for door and window frames, in a machine comprising a base (3); a clamping device (23) for at least one component (2); an operating head (12) for machining components (2); and a gripping and conveying assembly (15, 25) for transferring the components (2) to be machined and/or the newly machined components (2) between at least a first feeding station (30, 33) and the clamping device (23); the method being **characterized in that** it comprises the steps of:

feeding the components (2) to be machined to the first feeding station (30, 33) by means of a first movable carriage (41) having a plurality of reciprocally overlapping resting planes (P3); transferring each component (2) to be machined from the corresponding resting plane (P3) to a first lifting device (37) movable between the resting planes (P3); and transferring each component (2) to be machined from the first lifting device (37) to the gripping and conveying assembly (15, 25).

2. A method according to claim 1 and further comprising the step of:

firstly transferring each newly machined component (2) from the gripping and conveying assembly (15, 25) to the first lifting device (37), and then from the first lifting device (37) to a corresponding resting plane (P3) of the first carriage (41).

3. A method according to claim 2, wherein the gripping and conveying assembly (15, 25) comprises a first transfer device (25), which is connected to the first lifting device (37) at the first feeding station (30, 33), and has two reciprocally overlapping feeding planes (P1, P2) and a second transfer device (15) movable along the base (3) to transfer the components (2) between the first transfer device (25) and the clamping device (23); the method comprising the steps of:

transferring the components (2) to be machined from the first lifting device (37) to a first (P1) of said feeding planes (P1, P2); and transferring the newly machined components (2) from the second transfer device (15) to a second (P2) of said feeding planes (P1, P2).

4. A method according to claim 1 and further comprising the step of:

5  
10  
15  
20  
25  
30  
35  
40  
45  
50  
55

firstly transferring each newly machined component (2) from the gripping and conveying assembly (15, 25) to the first lifting device (37), and then from the first lifting device (37) to a corresponding resting plane (P3) of a second movable carriage different from the first carriage (41).

5. A method according to claim 1 and further comprising the step of:

firstly transferring each newly machined component (2) from the gripping and conveying assembly (15, 25) to a second lifting device different from the first lifting device (37), and then from the second lifting device to a corresponding resting plane (P3) of a second movable carriage different from the first carriage (41).

6. A method according to claim 5, wherein the gripping and conveying assembly (15, 25) comprises a first transfer device connected to the first lifting device (37) at the first feeding station (30, 33), a second transfer device connected to the second lifting device at a second feeding station different from the first feeding station (30, 33), and a third transfer device (15) movable along the base (3) to transfer the components (2) between said first and second transfer devices and the clamping device (23); the method comprising the steps of:

transferring the components (2) to be machined from the first lifting device (37) to the first transfer device; and  
transferring the newly machined components (2) from the second transfer device to the second lifting device.

7. A method according to any one of the preceding claims, wherein each resting plane (P3) of said each carriage (41) is defined by at least two belt conveyors (44) looped about respective pairs of pulleys (45) and provided with a pivoting supporting shaft (46) to which a pulley (45) of each belt conveyor (44) is mounted; the method comprising the steps of:

connecting the supporting shaft (46) to an electric motor (47) mounted in said corresponding feeding station (30, 33); and  
actuating the electric motor (47) either for moving the components (2) to be machined in said corresponding feeding station (30, 33) or for releasing the newly machined components (2) from said corresponding feeding station (30, 33).

8. A machine for machining wood components (2) or the like, specifically components (2) for door and window frames, comprising a base (3); a clamping device (23) for at least one component (2); an operating head (12) for machining components (2); and a gripping and conveying assembly (15, 25) for transferring the components (2) to be machined and/or the newly machined components (2) between at least one first feeding station (30, 33) and the clamping device (23); and

**characterized in that** it further comprises a first carriage (41) which has a plurality of reciprocally overlapping resting planes (P3), and is movable to feed the components (2) to be machined to the first feeding station (30, 33), and a first lifting device (37) movable between the resting planes (P3) to transfer each component (2) to be machined from the corresponding resting plane (P3) to the gripping and conveying plane (15, 25).

9. A machine according to claim 8, wherein the gripping and conveying assembly (15, 25) is movable along the base (3) to transfer the newly machined components (2) from the clamping device (23) to the first lifting device (37).

10. A machine according to claim 8, wherein the gripping and conveying assembly (15, 25) comprises a first transfer device (25), which is connected to the first lifting device (37) at the first feeding station (30, 33), and has two reciprocally overlapping feeding planes (P1, P2) and a second transfer device (15) movable along the base (3) to transfer the components (2) to be machined from a first (P1) of said feeding planes (P1, P2) to the clamping device (23) and the newly machined components (2) from the clamping device (23) to a second (P2) of said feeding planes (P1, P2).

11. A machine according to claim 8 and further comprising a second movable carriage which is different from the first carriage (41), has a plurality of reciprocally overlapping resting planes (P3), and is adapted to receive the newly machined components (2) from the first lifting device (37).

12. A machine according to claim 8 and further comprising a second lifting device, which is different from the first lifting device (37), and is adapted to receive the newly machined components (2) from the gripping and conveying assembly (15, 25), and a second movable carriage, which is different from the first carriage (41), and has a plurality of reciprocally overlapping resting planes (P3) adapted to receive the newly machined components (2) from the second lifting device.

13. A machine according to claim 12, wherein the gripping and conveying assembly (15, 25) comprises a

first transfer device connected to the first lifting device (37) at the first feeding station (30, 33) to receive the components (2) to be machined from the first lifting device (37) itself, a second transfer device connected to the second lifting device at a second feeding station different from the first feeding station (30, 33) to release the newly machined components (2) onto the second lifting device itself, and a third transfer device (15) movable along the base (3) to transfer the components (2) between the first and second transfer devices and the clamping device (23).

14. A machine according to any one of the claims from 8 to 13, wherein said each carriage (41) comprises, for each resting plane (P3), at least two belt conveyors (44), which define the resting plane (P3) itself, and are looped about respective pairs of pulleys (45), and at least one pivoting supporting shaft (46) to which a pulley (45) of each belt conveyor (44) is mounted.
15. A machine according to claim 14, wherein each said feeding station (30, 33) is provided with an electric motor (47) having an outlet shaft (49) selectively connectable to the supporting shaft (46) of one of said resting planes (P3) either to displace the corresponding components (2) to be machined in said corresponding feeding station (30, 33) or to release the corresponding newly machined components (2) from said corresponding feeding station (30, 33).
16. A machine according to claim 15, wherein the electric motor (47) is selectively movable between said resting planes (P3) orthogonally to the resting planes (P3) themselves.

40

45

50

55

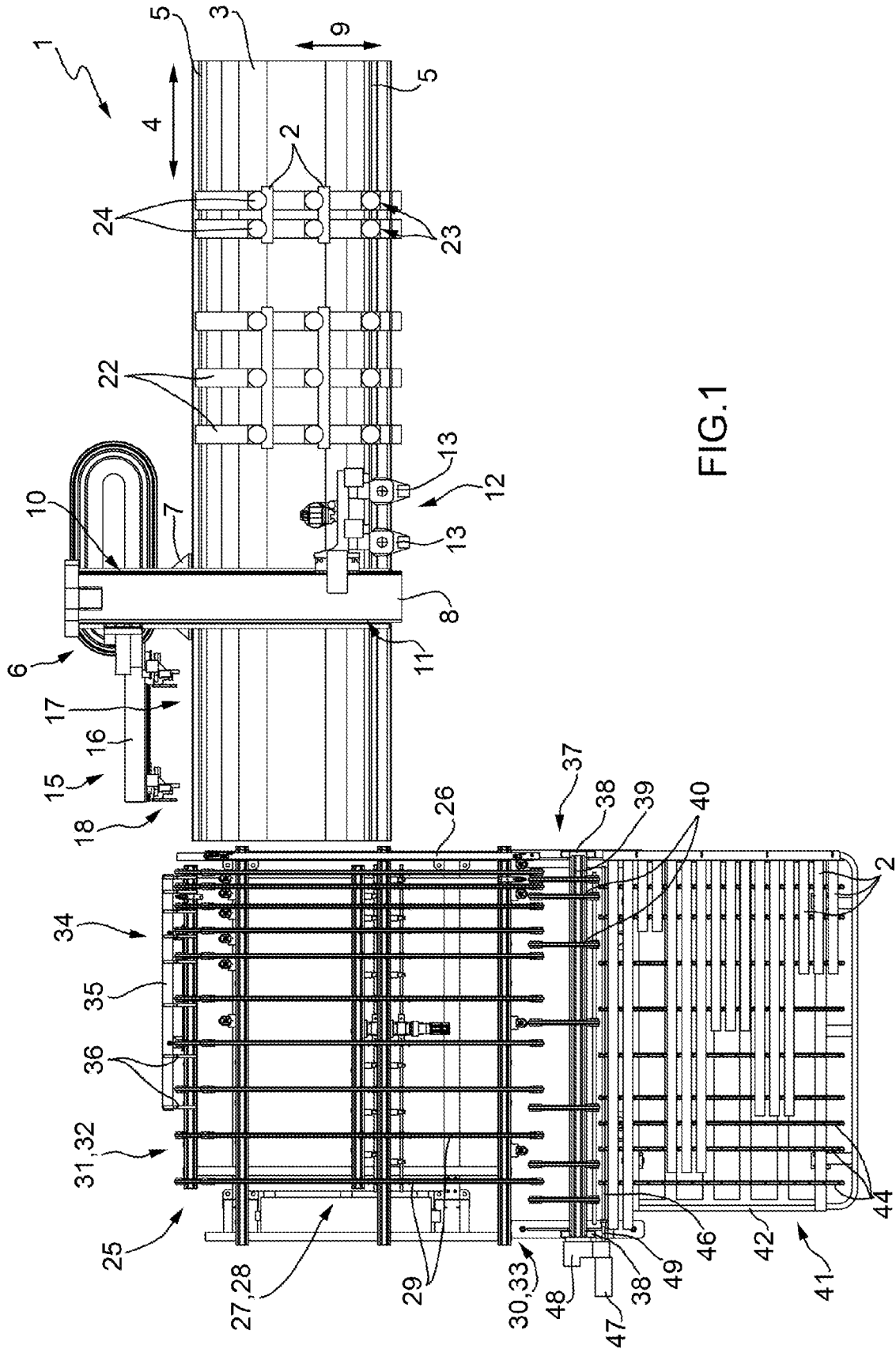
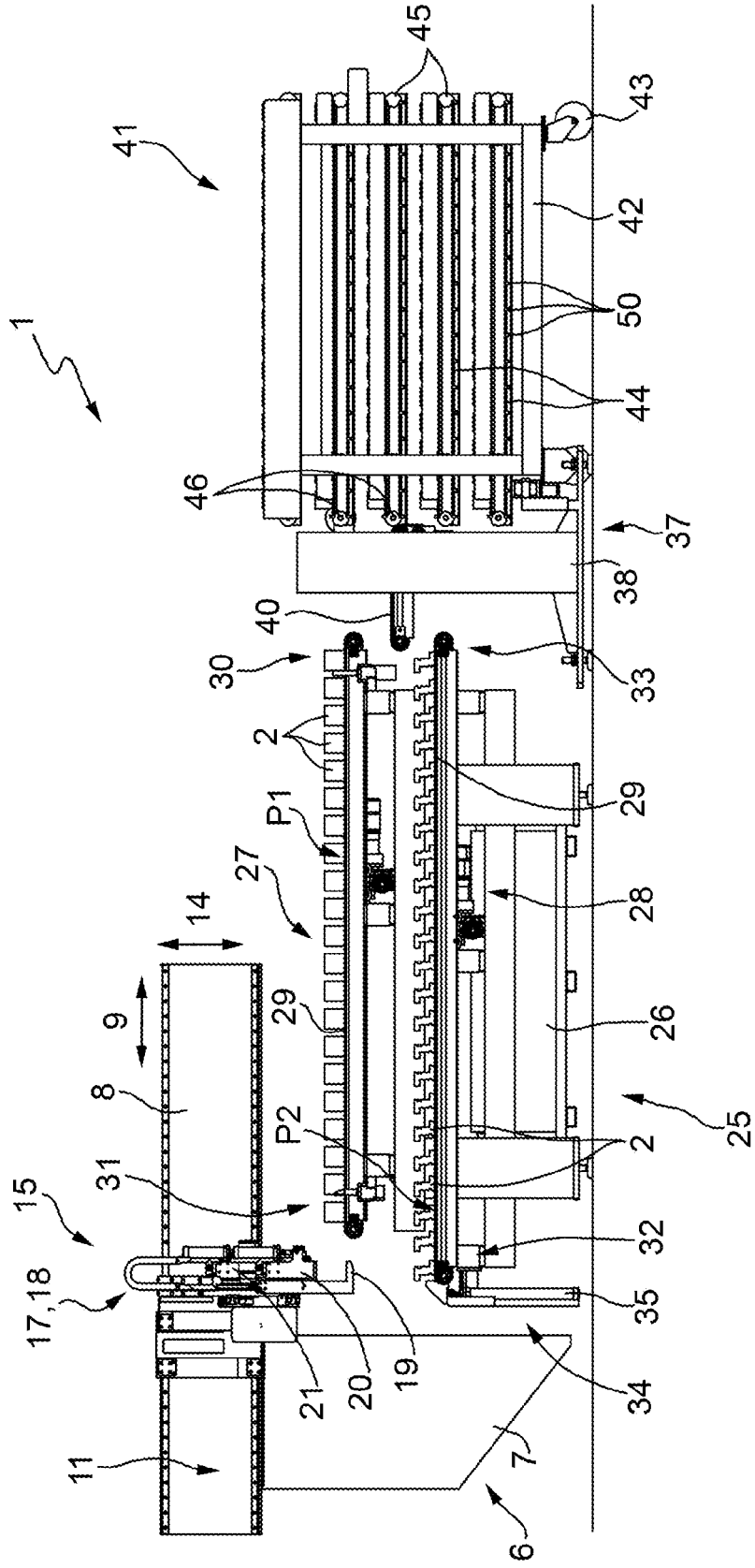

FIG.1



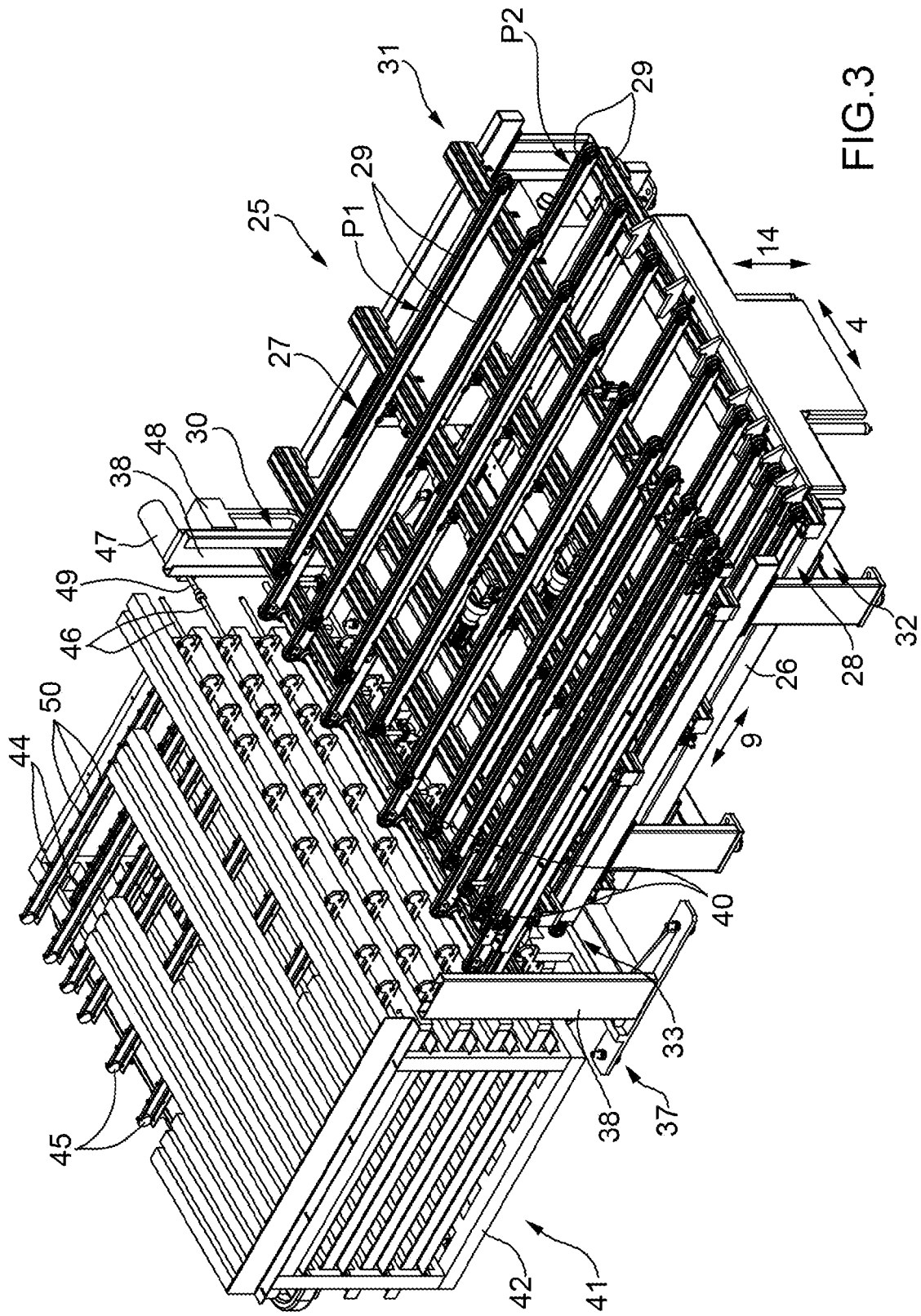

FIG. 3

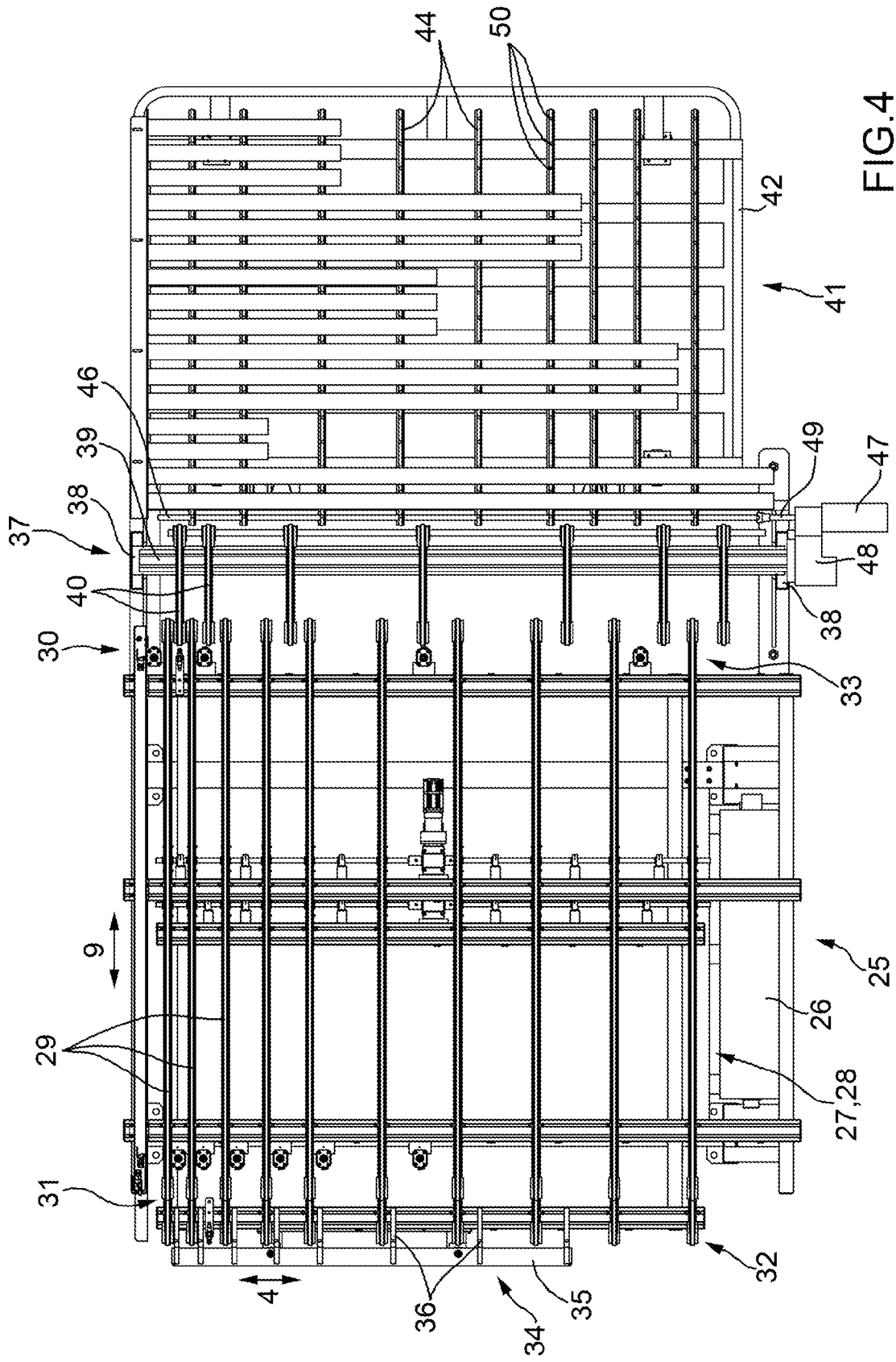

FIG.4



EUROPEAN SEARCH REPORT

Application Number  
EP 09 15 4162

DOCUMENTS CONSIDERED TO BE RELEVANT			
Category	Citation of document with indication, where appropriate, of relevant passages	Relevant to claim	CLASSIFICATION OF THE APPLICATION (IPC)
Y	IT B020 070 356 A1 (BIESSE SPA) 14 August 2007 (2007-08-14) * page 8, line 8 - page 10, line 3; figure 2 *	1,8	INV. B27M1/08 B65G65/00
Y	----- EP 0 335 658 A2 (WADKIN PUBLIC LTD CO [GB]) 4 October 1989 (1989-10-04) * column 2, line 60 - column 3, line 9; figure 2 *	1,8	
A	----- JP 2005 144963 A (MIYAGAWA KOKI CO LTD) 9 June 2005 (2005-06-09) * abstract; figures *	1,8	
A	----- FR 2 141 636 A1 (BAROUX ETS BAROUX ETS [FR]) 26 January 1973 (1973-01-26) * page 2, line 25 - page 3, line 40; figures *	1,8	
The present search report has been drawn up for all claims			TECHNICAL FIELDS SEARCHED (IPC)
			B27M B65G
Place of search		Date of completion of the search	Examiner
The Hague		1 July 2009	Garella, Mario
CATEGORY OF CITED DOCUMENTS		T : theory or principle underlying the invention E : earlier patent document, but published on, or after the filing date D : document cited in the application L : document cited for other reasons ..... & : member of the same patent family, corresponding document	
X : particularly relevant if taken alone Y : particularly relevant if combined with another document of the same category A : technological background O : non-written disclosure P : intermediate document			

2  
EPO FORM 1503 03.02. (P04C01)

**ANNEX TO THE EUROPEAN SEARCH REPORT  
ON EUROPEAN PATENT APPLICATION NO.**

EP 09 15 4162

This annex lists the patent family members relating to the patent documents cited in the above-mentioned European search report. The members are as contained in the European Patent Office EDP file on  
The European Patent Office is in no way liable for these particulars which are merely given for the purpose of information.

01-07-2009

Patent document cited in search report	Publication date	Patent family member(s)	Publication date
IT B020070356 A1	14-08-2007	EP 1992464 A2	19-11-2008
EP 0335658 A2	04-10-1989	NONE	
JP 2005144963 A	09-06-2005	NONE	
FR 2141636 A1	26-01-1973	NONE	

EPO FORM P0459

For more details about this annex : see Official Journal of the European Patent Office, No. 12/82