



(11) **EP 2 101 130 A1**

(12) **EUROPEAN PATENT APPLICATION**  
published in accordance with Art. 153(4) EPC

(43) Date of publication:  
**16.09.2009 Bulletin 2009/38**

(51) Int Cl.:  
**F25D 21/14 (2006.01)**

(21) Application number: **07866359.8**

(86) International application number:  
**PCT/ES2007/000729**

(22) Date of filing: **13.12.2007**

(87) International publication number:  
**WO 2008/071824 (19.06.2008 Gazette 2008/25)**

(84) Designated Contracting States:  
**AT BE BG CH CY CZ DE DK EE ES FI FR GB GR  
HU IE IS IT LI LT LU LV MC MT NL PL PT RO SE  
SI SK TR**

(71) Applicant: **Santana Leon, Francisco Javier**  
**38001 Santa Cruz de Tenerife (ES)**

(30) Priority: **15.12.2006 ES 200603198**

(72) Inventor: **Santana Leon, Francisco Javier**  
**38001 Santa Cruz de Tenerife (ES)**

(54) **AUTOMATIC SYSTEM FOR EVAPORATION OF CONDENSATES**

(57) Consists of the installation of a set of condensation control elements on to the lower rear part of the external condenser units of air-conditioning systems, permitting the elimination by evaporation of the liquid formed in the air-conditioning process.

depending on the level of liquid in the container, activates the pump, which pumps the water through pipes connected to the rear ventilation grille and releases it on to the condenser through atomizers at the end of the pipes, causing the liquid to evaporate, thereby making it unnecessary to install condensed liquid drainage pipes and improving heat efficiency by cooling the ventilation grille of the condenser unit.

The system is made up of an electric liquid level sensor, which is connected to the liquid collection container on the bottom of the external condenser unit, and which,

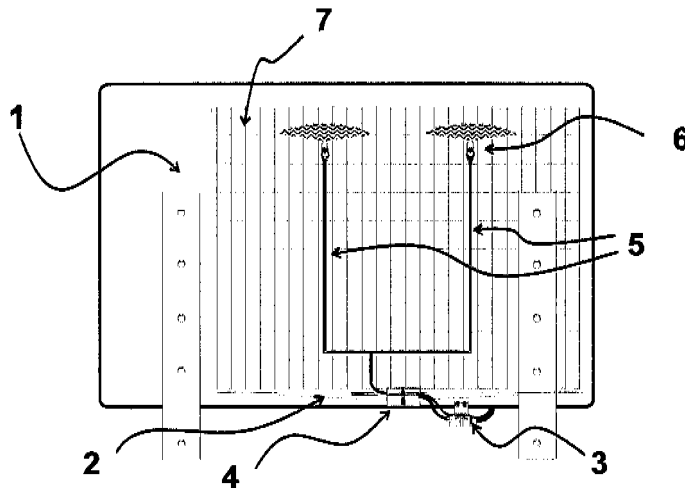

**Fig. 1**

**EP 2 101 130 A1**

## Description

### PURPOSE OF THE INVENTION

[0001] The Invention Patent to which this Report refers is intended to guarantee the exclusive use and ownership, throughout the country, of an automatic system of evaporation of the condensed liquid from air-conditioning and cooling units.

### SCOPE OF THE INVENTION

[0002] The application of this invention is in the temperature and moisture exchange requirements, especially the evaporation of the liquid condensed during the air-conditioning process (F25), which arise in evaporators due to condensation.

This invention has two important purposes: firstly, it solves one of the most serious problems of domestic air-conditioning units, namely, the present need for complicated systems for the drainage of condensed liquids and, secondly, it significantly increases the heat efficiency of the unit and reduces power consumption.

### BACKGROUND OF THE INVENTION.

[0003] Nowadays, air-conditioning is the most complete process of ambient air treatment, involving the regulation of conditions in terms of temperature (heating or cooling), moisture and quality (renewal, filtering).

[0004] Over the last few years, the installation of air-conditioning units has become an essential requirement to achieve people's wellbeing in domestic, work and leisure environments.

The technique has advanced to such an extent that, nowadays, there are many low-price, high-performance, easily installed, noise-free air-conditioning systems on the market, but they all lack optimum systems for the elimination of the condensed liquids produced by the various units of which they are composed.

### DESCRIPTION OF THE INVENTION.

[0005] The invention consists of an adaptation to the external condenser unit, such that by installing the device for collecting the water condensed in the air-conditioning process, in which a simple electric pump for condensed liquids, a liquid level sensor and a set of small vertical pipes with atomizers at the end are installed, the condensed water is pumped over the external unit condenser and, thanks to the high temperature of the latter and the action of the equipment's fan, along with moisture exchange, the condensed liquid evaporates into the outside air, eliminating the need to include drainage pipes and/or containers for the collection of condensed liquids.

## DESCRIPTION OF THE DIAGRAMS.

[0006] To better understand the scope of this invention, we are going to describe it using the attached diagrams, which show a preferred design of the same, given as an example but not being the only possibility.

[0007] Figure 1 shows a rear view of an external condenser unit with the invention installed and

[0008] Figure 2 shows a side view of the same.

[0009] We can see that, in the diagrams, (1) represents the external condenser unit of an air-conditioning system, (2) the container for condensed liquids, (3) the liquid level sensor, (4) the pump, (5) the vertical pipes, (6) the atomizers and (7) the ventilation grille.

### PREFERENTIAL FORMAT OF THE INVENTION

[0010] As you can see in the diagrams, the invention is located on the condenser unit of an air-conditioning system (1) and consists of a liquid level sensor (3), which detects the presence and level of liquid accumulated in the condensed liquid collection container (2) and, when the liquid in the container reaches a high enough level, activates the electric pump (4). The latter pumps the condensed liquid through the rear vertical pipes (5), attached to the external condenser unit ventilation grille, from which it is released through the atomizers (6) in the form of a fine spray.

The water released through the atomizers (6) falls directly on to the rear ventilation grille (7) of the condenser unit (1), where it quickly evaporates due both to the temperature of the condenser and the effect of the internal fan of the condenser, as well as the moisture of the outside air.

[0011] When the level of liquid in the condensed liquid collection container (2) drops, this is detected by the sensor, which turns off the pump and therefore the atomizers.

[0012] As you can see, the invention is as effective as it is simple and original. This set of elements: the sensor, the pump, the pipes and the atomizers are easy to handle and install and inexpensive.

[0013] With the invention, installation costs are also significantly reduced, since, as already mentioned, it makes it unnecessary to install drainage pipes, which often disfigure the facades of buildings. Energy costs are also reduced, since the water released on to the ventilation grille by the atomizers aids in the elimination of heat and improves the heat efficiency of the installation, as shown in the attached diagrams.

[0014] Apart from the basic invention, the patent also includes variations in detail, such that there may be variations in the type of level sensor and pump, the characteristics and quantity of pipes and atomizers, the size of the different parts of the system and, naturally, the material used.

**Claims**

1. **Automatic condensed liquid evaporation system.-characterized by** being made up of a combination of elements consisting of a liquid pump, a liquid level sensor and a set of pipes with atomizers on the end, which are placed on the external condenser units of air-conditioning systems in such a way as to collect the condensed liquid which accumulates in the lower tray of the condenser and release it in the form of a fine spray over the top of the ventilation grille of the external condenser unit.  
5  
10
  
2. **Automatic condensed liquid evaporation system, as in the 1st claim, and it is also characterized by** the fact of possessing an electric liquid level sensor which activates the pump-also electric-only when it detects the presence of a high enough level of liquid in the tray for the collection of water from the drainage pipes of the evaporating and condensing units of the air-conditioning system.  
15  
20

25

30

35

40

45

50

55

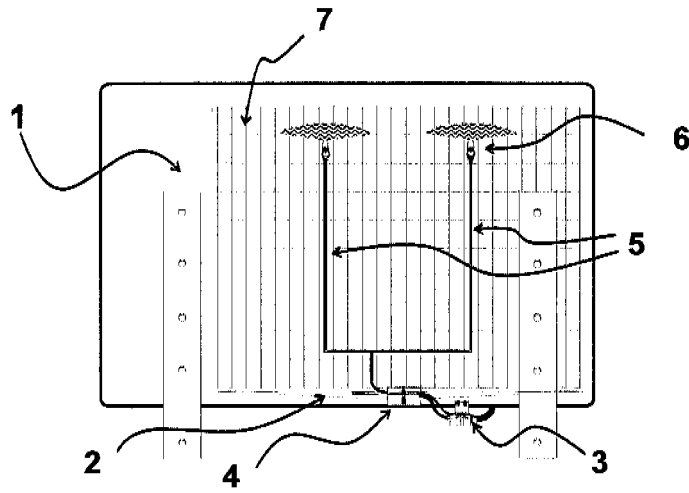

Fig. 1

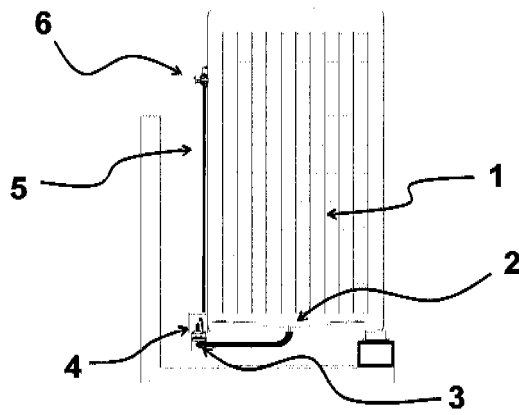

Fig. 2

INTERNATIONAL SEARCH REPORT

International application No.  
PCT/ ES 2007/000729

A. CLASSIFICATION OF SUBJECT MATTER		
<b>F25D 21/14</b> (2006.01)		
According to International Patent Classification (IPC) or to both national classification and IPC		
B. FIELDS SEARCHED		
Minimum documentation searched (classification system followed by classification symbols) F25B,F25D,F24F		
Documentation searched other than minimum documentation to the extent that such documents are included in the fields searched		
Electronic data base consulted during the international search (name of data base and, where practicable, search terms used) CIBEPAT,EPODOC		
C. DOCUMENTS CONSIDERED TO BE RELEVANT		
Category*	Citation of document, with indication, where appropriate, of the relevant passages	Relevant to claim No.
X	JP 59071937 A (MATSUSHITA SEIKO KK) 23.04.1984, Retrieved from the: EPO PAJ.	1
Y		2
Y	US 4748821 A (BERENTER.) 07.06.1988, column 1, lines 21-22.	2
X	JP 2003202179 A (SENDAK CORP) 18.07.2003, Retrieved from the: EPO PAJ.	1
A	US 2005166614 A1 (DOBMEIER et al.) 04.08.2005, paragraph [30].	
A	JP 59119123 A (MATSUSHITA ELECTRIC IND CO LTD) 10.07.1984, Retrieved from the: EPO PAJ.	
<input type="checkbox"/> Further documents are listed in the continuation of Box C. <input checked="" type="checkbox"/> See patent family annex.		
* Special categories of cited documents:	"T"	later document published after the international filing date or priority date and not in conflict with the application but cited to understand the principle or theory underlying the invention
"A" document defining the general state of the art which is not considered to be of particular relevance.		
"E" earlier document but published on or after the international filing date		
"L" document which may throw doubts on priority claim(s) or which is cited to establish the publication date of another citation or other special reason (as specified)	"X"	document of particular relevance; the claimed invention cannot be considered novel or cannot be considered to involve an inventive step when the document is taken alone
"O" document referring to an oral disclosure use, exhibition, or other means	"Y"	document of particular relevance; the claimed invention cannot be considered to involve an inventive step when the document is combined with one or more other documents, such combination being obvious to a person skilled in the art
"P" document published prior to the international filing date but later than the priority date claimed	"&"	document member of the same patent family
Date of the actual completion of the international search 14.March.2008 (14.03.2008)	Date of mailing of the international search report (21/05/2008)	
Name and mailing address of the ISA/ O.E.P.M. Paseo de la Castellana, 75 28071 Madrid, España. Facsimile No. 34 91 3495304	Authorized officer J. A. Celemín Ortiz-Villajos Telephone No. +34 91 349 54 93	

**EP 2 101 130 A1**

**INTERNATIONAL SEARCH REPORT**

Information on patent family members

International application No.

PCT/ES 2007/000729

Patent document cited in the search report	Publication date	Patent family member(s)	Publication date
JP 59071937 A	23.04.1984	NONE	-----
US 4748821 A	07.06.1988	NONE	-----
JP 2003202179 A	18.07.2003	NONE	-----
US 2005166614 A	04.08.2005	US 7013658 B WO 2005075909 A	21.03.2006 18.08.2005
JP 59119123 A	10.07.1984	JP 61044213 B JP 1375014 C	01.10.1986 22.04.1987

Form PCT/ISA/210 (patent family annex) (April 2007)