

Description

[0001] The present invention generally relates to electrical outlets for industrial or service sector use, and particularly relates to an interlocked electrical outlet.

[0002] Interlocked electrical outlets are electrical power distribution devices which can be mounted on a wall or installed on special support panels.

[0003] An interlocked electrical outlet generally comprises a housing provided with connection means for wall assembly, for example, a plurality of holes adapted to receive securing screws. The housing accommodates an electrical switch, an electrical outlet adapted to receive a corresponding electrical plug (for example, in accordance with the European standard EN 60309 concerning industrial electrical connectors), and electrically connected to the switch so as to be able to allow and interrupt the power supply, as well as an interlock mechanism interacting with switch and electrical outlet so that the electrical outlet can receive and release the plug only after the switch has been turned off and the switch can be turned on only after the plug has been plugged into the electrical outlet.

[0004] Optionally, a protecting device can be provided, for example, a fuse assembly which is electrically connected between switch and electrical outlet.

[0005] In known interlocked outlets with a fuse-carrier assembly, the individual fuses, the fuse-carrier or a door closing and protecting the space containing the fuse-carrier assembly are also accessible when the electric switch is activated, thus resulting in the risk for the operator to be in contact with conductive components and be subjected to electric shock of considerable amperage.

[0006] The object of the present invention is thus to provide an interlocked electrical outlet having such characteristics as to eliminate the risk of electrical shock caused by any inadvertent access to the fuse-carrier assembly, when the fuse-carrier assembly is energized.

[0007] This and other objects are achieved by an interlocked electrical outlet according to claim 1.

[0008] According to the invention, the interlocked electrical outlet comprises:

- a housing;
- an electrical outlet accommodated in the housing and adapted to receive a corresponding electrical plug;
- a switch received in the housing and electrically connected to the electrical outlet so as to be able to allow and interrupt the power supply;
- an interlock mechanism accommodated in the housing and interacting with switch and electrical outlet so that the electrical outlet can receive and release the plug only after the switch has been turned off, and the switch can be turned on only after the plug has been plugged in the electrical outlet,
- a fuse-carrier assembly comprising one or more individual fuse-carrier devices, each adapted to hold a

fuse, and provided with contact terminals in order to allow the fuse electrical connection in the power supply lines between switch and electrical outlet,

5 wherein the interlock mechanism further comprises one or more fuse-carrier locking portions which interact with the individual fuse-carrier devices such that, when the switch and the interlock mechanism are in the electrical connection configuration, said fuse-carrier locking portion locks the fuse-carrier device in a closed configuration, thereby preventing the individual fuse from being accessed, and only when the switch and interlocking mechanism are in the power interruption configuration, said fuse-carrier locking portion releases the fuse-carrier device thereby allowing the latter to be opened.

[0009] In accordance with an aspect of the present invention, the fuse-carrier locking portions may comprise at least one plug which is suitable to engage, when the interlock mechanism and switch are in the power connection configuration, a corresponding seat or hole being formed in a fuse drawer of the fuse-carrier device to prevent the fuse-drawer from being opened.

Due to the fuse-carrier locking portions, when the switch is activated, both an individual fuse and the seat thereof that is formed by the fuse-carrier device cannot be accessed, thereby completely eliminating the risk of electric shock that may arise from any inadvertent contact with conductive parts of the fuse-carrier assembly.

The dependant claims relate to advantageous embodiments.

[0010] In order to better understand the invention, and appreciate the advantages thereof, a detailed description of some exemplary, non-limiting embodiments will be set forth herein below, with reference to the annexed drawings, in which:

[0011] Fig. 1 is an exploded view of an interlocked electrical outlet according to an embodiment;

[0012] Fig. 2 is a perspective view of a fuse-carrier assembly of the interlocked electrical outlet in Fig. 1 with a fuse-carrier locking portion being in a disengaged configuration,

[0013] Fig. 3 is a perspective view of the fuse-carrier assembly and fuse-carrier locking portion in Fig. 2 in the engaged configuration,

[0014] Fig. 4 is a perspective view of a front shell of the interlocked outlet when assembled (the wiring has been omitted for clarity purposes),

[0015] Fig. 5 is a front perspective view of the interlocked outlet according to an embodiment (a rear shell has been omitted),

[0016] Fig. 6 is a perspective view of an interlock mechanism according to a further embodiment with a closed-section latch with two side bars.

[0017] With reference to the Figures, an interlocked electrical outlet is generally designated with the reference numeral 1. The interlocked outlet 1 comprises a housing 2, inside which an electrical outlet 3 is accommodated which is adapted to receive a corresponding electrical

plug (not shown), a switch 4 electrically connected to the electrical outlet 3 so as to be able to thereby turn on and off the power supply, and an interlock mechanism 5 interacting with switch 4 and electrical outlet 3, so that the electrical outlet 3 can receive and release the plug only after the switch has been turned off, and the switch 4 can be turned on only after the plug has been plugged in the electrical outlet 3.

[0018] The switch 4, particularly a shaft 30 thereof or actuating handle 31 of switch 4, comprise a dragging portion 32, for example, an eccentric pin actuating an interlock mechanism 5, which will be described herein below.

[0019] The interlocked outlet 1 comprises a fuse-carrier assembly 33 which is electrically connected between the switch 4 and outlet 3.

[0020] The fuse-carrier assembly 33 can comprise a plurality of individual fuse-carrier devices 34, each adapted to hold a fuse, and provided with contact terminals in order to allow the fuse electrical connection in the power supply lines between switch 4 and electrical outlet 3.

[0021] The interlock mechanism 5 comprises a latch 48 movably arranged, preferably translatable, in a latch seat 49 formed in the housing 2. The latch 48 comprises an actuating seat 50 connected to the switch 4 dragging portion 32 so that a switching of the switch 4 between a connection position and a power supply interruption position involves a corresponding movement of the latch 48 between a connection position and a power interruption position.

[0022] The latch 48 comprises a plug locking portion 51 arranged at an outlet seat 21 of housing 2 and configured so that:

[0023] when the plug has been plugged in outlet 3, the plug locking portion 51 results disengaged from the outlet 3 or outlet seat 21, thus allowing a latch 48 movement between the electrical connection position to the power interruption position, and vice versa, and

[0024] when the plug has been unplugged, the plug locking portion 51 results constraint by the outlet 3 or outlet seat 21 in the power interruption position, thus preventing a latch 48 movement from the power interruption position to the electrical connection position and

[0025] when the latch 48 has been arranged in the power interruption position, the plug locking portion 51 releases the outlet 3 or outlet seat 21, thus allowing the plug plug-in and withdrawal and

[0026] when the latch 48 has been arranged in the electrical connection position, the plug locking portion 51 directly or indirectly engages the plug, thus preventing the withdrawal of the latter from the outlet 3.

[0027] In accordance with an aspect of the invention, the latch 48 or, generally, the interlock mechanism 5, further comprises a door locking portion 52 interacting with a corresponding hook 53 of a fuse-carrier door 54 so that, when the latch 48 is in the electrical connection position, the door locking portion 52 fastens the fuse-carrier door 54 in the closed position, thus preventing the

latter from being opened, thereby preventing access to the fuse-carrier devices and, when the latch 48 is in the power interruption position, the door locking portion 52 releases the fuse-carrier door 54, thus allowing the latter to be opened.

[0028] In accordance with a further embodiment, the latch 48 or, generally, the interlock mechanism 5, can further comprise one or more fuse-carrier locking portions 55 interacting with the individual fuse-carrier devices 34 so that, when the latch 48 is arranged in the electrical connection position, the fuse-carrier locking portion 55 fastens the fuse-carrier device 34 to a closed configuration, thus preventing access to the individual fuse and, only when the latch 48 is in the power interruption position, the fuse-carrier locking portion 55 releases the fuse-carrier device 34, thus allowing the opening of the latter.

[0029] Preferably, the fuse-carrier locking portions 55 comprise at least one pin adapted to engage, when the latch 48 is in an electrical connection position, a corresponding seat or hole 56 formed in a fuse drawer 57 (supporting the fuse) of the fuse-carrier device 34 in order to prevent the fuse drawer 57 from being opened.

[0030] In accordance with a preferred embodiment, the fuse-carrier assembly comprises a plurality of fuse-carrier devices 34, each being provided with its own fuse drawer 57 with a seat or hole 56 suitable to receive one or a series of plugs 55, respectively, which is configured in a "comb-like shape" such as to prevent the fuse drawer 34 from being opened (withdrawn).

[0031] According to an embodiment of the invention, the latch 48 is hold in place by a preferably screwless shape connection in an interspace between switch 4 and switch seat 25 of the housing 2.

[0032] Fig. 4 further illustrates a pushing device 58 secured to the housing 2 by means of screws or, alternatively, by a snap connection or by press-fit, and provided with an elastic arm 59 acting with an elastic pre-load on a portion (for example, the hook 53) of the fuse-carrier door 54 in order to make the opening thereof easier (when the switch and interlock mechanism are in the electrical interruption position).

[0033] In accordance with an embodiment, all the electrical components electrical outlet, switch, interlock mechanism, and fuse-carrier assembly are directly connected to a housing 2 front shell 60, which can, in turn, be connected by means of screws 61 to a rear shell or other support, such as on a wall, in order to complete assembly and installation.

[0034] According to embodiments of the invention, the interlock mechanism may comprise a rack-, geared-, articulated quadrilateral-, spring-, cam-, belt- mechanism, or similar mechanical devices, which are suitable to transmit and transform the switch motion into a lock/release motion of the locking portions.

[0035] The interlocked electrical outlet according to the present invention is particularly safe in that it eliminates the risk of electrical shocks which may be due to the operator coming in contact with the outlet and fuse-carrier

assembly.

[0036] Due to the particular configuration of the latch of the interlock mechanism and fuse-carrier devices, the interlock mechanism results to be substantially planar and plate-like and, therefore, particularly suitable for assembly in narrow space conditions.

[0037] It shall be apparent that to the interlocked electrical outlet according to the present invention, one skilled in the art, to the aim of meeting specific, contingent needs, will be able to make further modifications and variations, all of which anyhow fall within the protection scope of the invention, as defined by the following claims.

Claims

1. Interlocked electrical outlet (1) comprising:

- a housing (2);
- an electrical outlet (3) accommodated in the housing (2) and adapted to receive a corresponding electrical plug;
- a switch (4) accommodated in the housing (2) and electrically connected to the electrical outlet (3) so as to be able to allow and interrupt the power supply;
- an interlock mechanism (5) accommodated in the housing (2) and interacting with switch (4) and electrical outlet (3) so that the electrical outlet can receive and release the plug only when the switch has been turned off, and the switch can be turned on only when the plug has been plugged in in the electrical outlet,
- a fuse-carrier assembly (33) comprising one or more individual fuse-carrier devices (34), each adapted to hold a fuse, and provided with contact terminals in order to allow the fuse electrical connection in the power supply lines between switch (4) and electrical outlet (3),

characterized in that said interlock mechanism (5) comprises one more fuse-carrier locking portions (55) which interact with the individual fuse-carrier device (34) such that, when the switch (4) and interlock mechanism (5) are in the electrical connection configuration, said fuse-carrier locking portion (55) fastens the at least one fuse-carrier device (34) in a closed configuration, thereby preventing an individual fuse from being accessed, and

- only when the switch (4) and interlock mechanism (5) are in the power interruption configuration, said fuse-carrier locking portion (55) disengages the at least one fuse-carrier device (34), thereby allowing the latter to be opened.

2. The interlocked electrical outlet (1) according to claim 1, wherein said interlock mechanism (5) com-

prises a latch (48) being arranged in a movable manner, preferably translatable, within a latch seat (49) that is formed in said housing (2), said latch (48) comprising:

- an actuating seat (50) being connected to a dragging portion (32) of the switch (4) such that a switching of the switch (4) between a connection position and a power supply interruption position involves a corresponding movement of the latch (48) between a connection position and a power interruption position,
- a plug locking portion (51) arranged at an outlet seat (21) of the housing (2) and configured so that:

A) when the plug has been plugged in the outlet (3), the plug locking portion (51) results to be disengaged from the outlet (3) or outlet seat (21), thereby allowing a latch (48) movement from the electrical connection position to the power interruption position, and vice versa, and

B) when the plug is unplugged from outlet (3), the plug locking portion (51) results to be engaged by the outlet (3) or outlet seat (21) in the power interruption position, preventing a latch (48) movement from the power interruption position to the electrical connection position and

C) when the latch (48) is arranged in the power interruption position, the plug locking portion (51) releases the outlet (3) or outlet seat (21), thus allowing the plug to be either plugged or withdrawn, and

D) when the latch (48) is arranged in the electrical connection position, the plug locking portion (51) directly or indirectly engages the plug, thus preventing the withdrawal of the latter from the outlet (3).

3. The interlocked electric outlet (1) according to claim 1 or 2, wherein said interlock mechanism (5) further comprises a door locking portion (52) interacting with a corresponding hook (53) of a fuse-carrier door (54) so that, when the interlock mechanism (5) is arranged in the electrical connection position, said door locking portion (52) fastens the fuse-carrier door (54) in the closed position, preventing the opening of the latter, thereby preventing access to the fuse-carrier devices and, when the interlock mechanism (5) is arranged in the power interruption position, said door locking portion (52) releases said fuse-carrier door (54), allowing the opening of the latter.

4. The interlocked electric outlet (1) according to claim 3, wherein said door-locking portion (52) is formed

as one piece with said latch (48).

- 5. The interlocked electric outlet (1) according to any preceding claim,
 wherein said fuse-carrier device (34) comprises a fuse drawer (57) which is suitable to carry the fuse, said fuse drawer (57) being movably supported between an inserted position in which the fuse is closed within the fuse-carrier device (34) and a withdrawn position to allow access to the fuse,
 wherein said fuse-carrier locking portion (55) comprises at least one plug (55) which is suitable to engage, when the interlock mechanism (5) is in the electrical connection position, a corresponding seat (56) being formed in said fuse drawer (57) such as to prevent said fuse drawer (57) from being opened.

- 6. The interlocked electric outlet (1) according to the preceding claim, wherein said fuse-carrier assembly comprises a plurality of fuse-carrier devices, each being provided with its own fuse drawer with a seat or hole suitable to receive one of a series of plugs, respectively, and wherein said plugs are arranged in a same plane and are formed as one piece with said latch (48).

- 7. The interlocked electrical outlet (1) according to any preceding claim, wherein said interlock mechanism (5) comprises a latch (48) that is movably arranged in a latch seat (49) being formed in the housing, wherein a portion of the latch (48) is firmly locked in an interspace between switch (4) and a switch seat (25) of the housing (2).

5

10

15

20

25

30

35

40

45

50

55

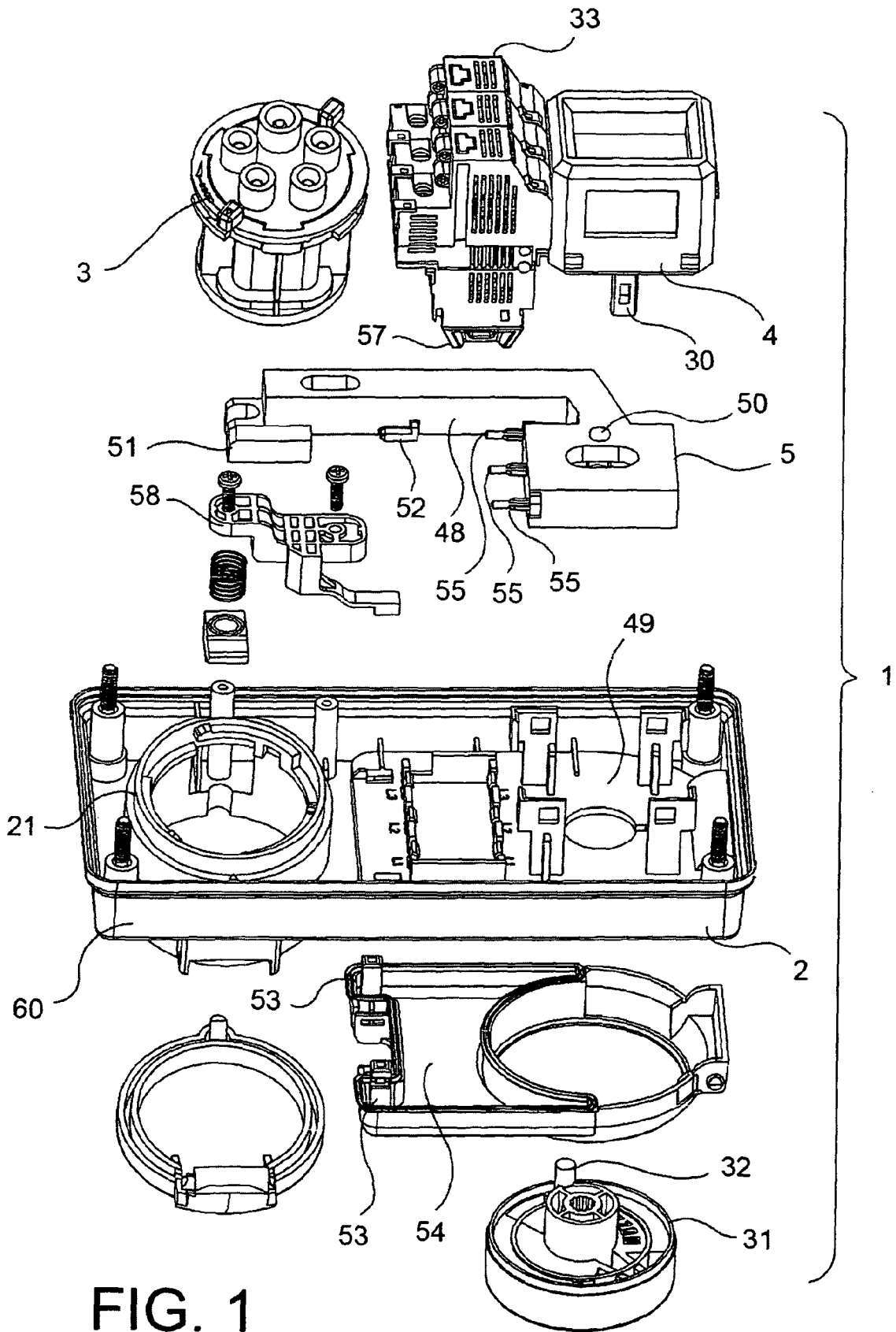

FIG. 1

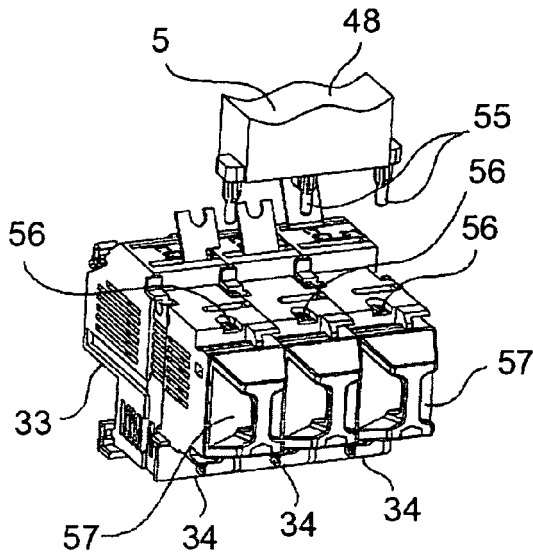

FIG. 2

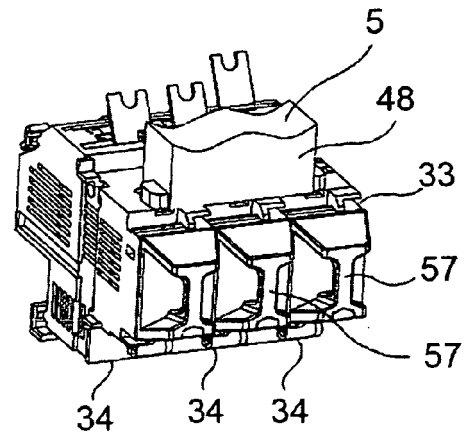

FIG. 3

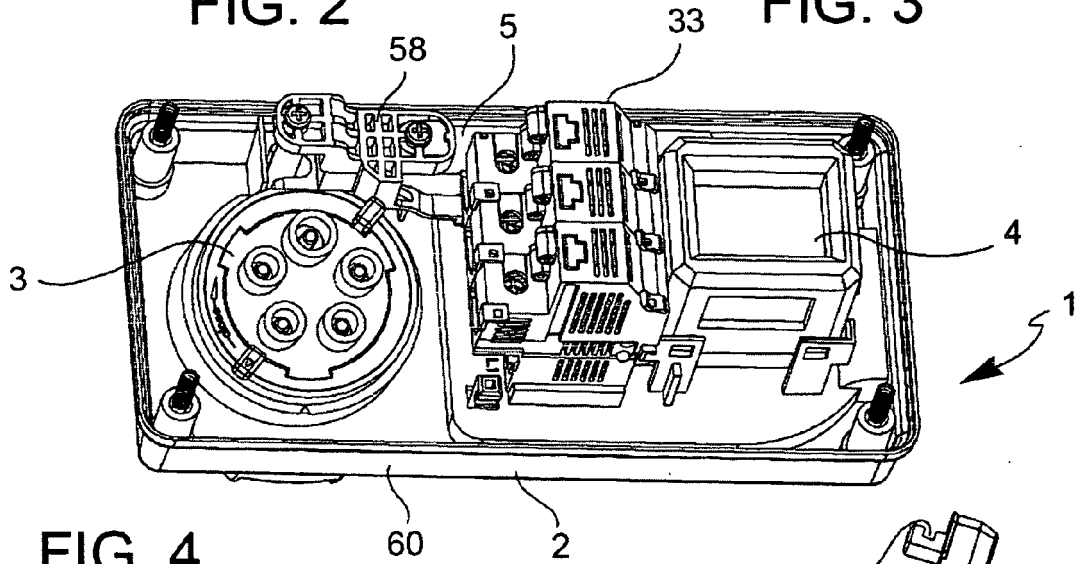

FIG. 4

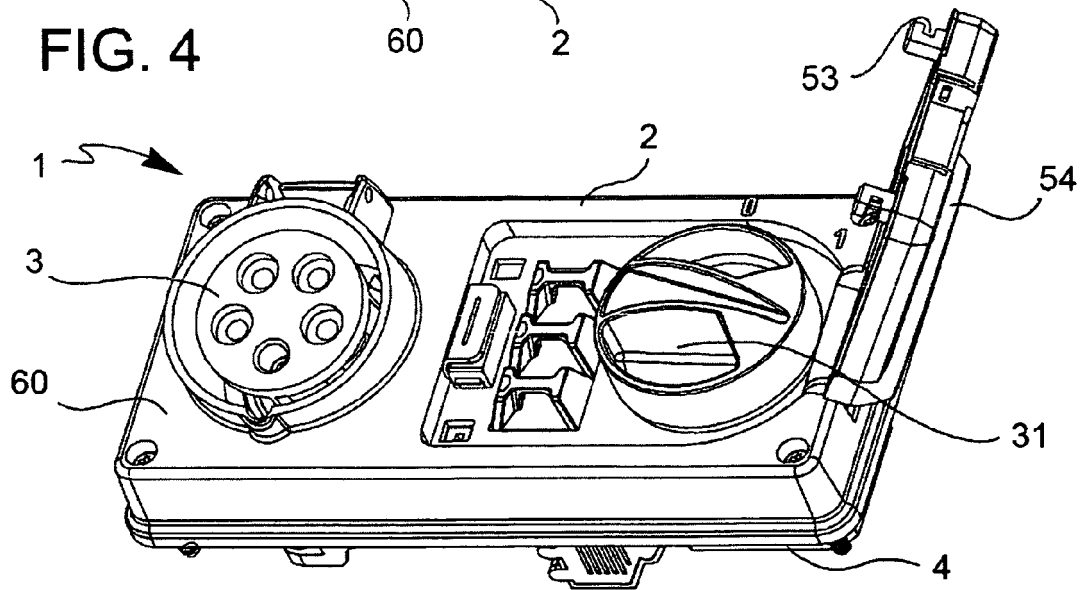

FIG. 5

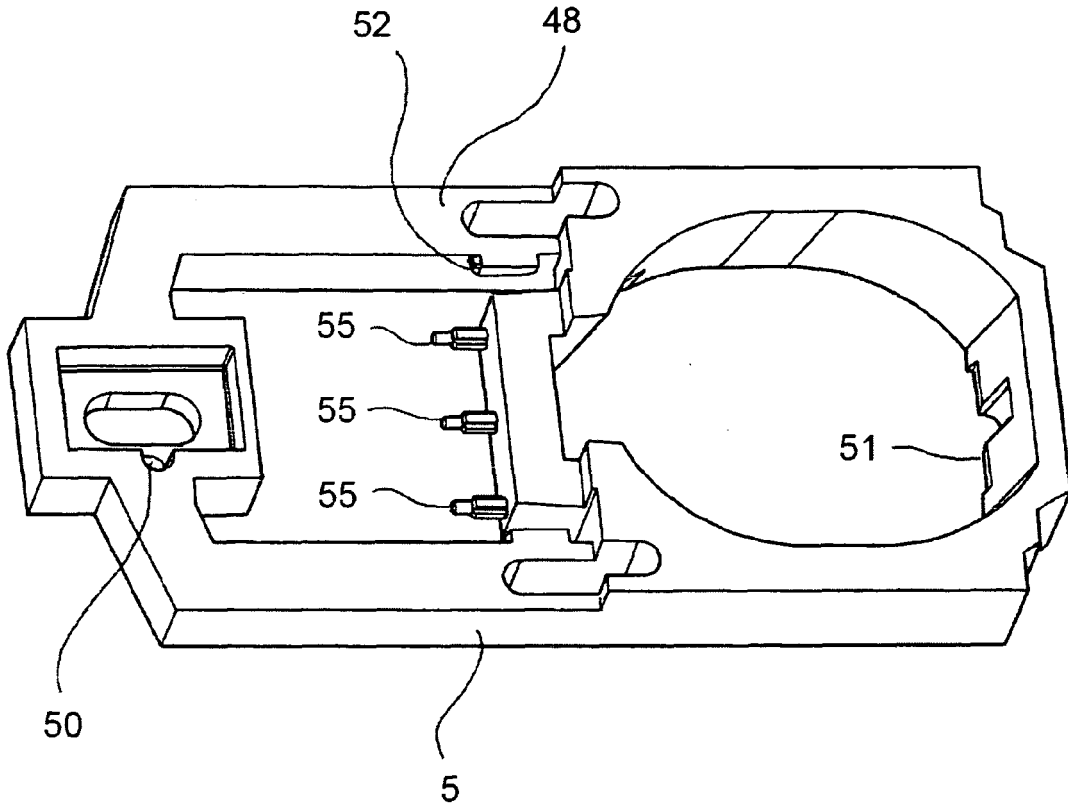

FIG. 6



EUROPEAN SEARCH REPORT

Application Number
EP 08 42 5314

DOCUMENTS CONSIDERED TO BE RELEVANT			
Category	Citation of document with indication, where appropriate, of relevant passages	Relevant to claim	CLASSIFICATION OF THE APPLICATION (IPC)
A	US 2002/092742 A1 (ROHMER RICHARD [US] ET AL) 18 July 2002 (2002-07-18) * abstract * * page 2, paragraph 23; figures 1-4 * -----	1-7	INV. H01R13/707 H01R13/68 H01R13/713
A	DE 10 16 793 B (BUSCH JAEGER DUERENER METALL) 3 October 1957 (1957-10-03) * column 1, lines 1-26; figures 1-3 * -----	1-7	
A	DE 202 04 816 U1 (ILME SPA [IT]) 6 June 2002 (2002-06-06) * abstract * * page 5, paragraph 3; figures 1-3 * -----	1-7	
			TECHNICAL FIELDS SEARCHED (IPC)
			H01R
The present search report has been drawn up for all claims			
Place of search Munich		Date of completion of the search 17 October 2008	Examiner Kardinal, Ingrid
<p>CATEGORY OF CITED DOCUMENTS</p> <p>X : particularly relevant if taken alone Y : particularly relevant if combined with another document of the same category A : technological background O : non-written disclosure P : intermediate document</p> <p>T : theory or principle underlying the invention E : earlier patent document, but published on, or after the filing date D : document cited in the application L : document cited for other reasons & : member of the same patent family, corresponding document</p>			

2
EPO FORM 1503 03.02 (P04CO1)

**ANNEX TO THE EUROPEAN SEARCH REPORT
ON EUROPEAN PATENT APPLICATION NO.**

EP 08 42 5314

This annex lists the patent family members relating to the patent documents cited in the above-mentioned European search report. The members are as contained in the European Patent Office EDP file on The European Patent Office is in no way liable for these particulars which are merely given for the purpose of information.

17-10-2008

Patent document cited in search report	Publication date	Patent family member(s)	Publication date
US 2002092742 A1	18-07-2002	CA 2365317 A1 MX PA01013191 A	21-06-2002 25-06-2004
-----	-----	-----	-----
DE 1016793 B	03-10-1957	NONE	
-----	-----	-----	-----
DE 20204816 U1	06-06-2002	NONE	
-----	-----	-----	-----

EPO FORM P0459

For more details about this annex : see Official Journal of the European Patent Office, No. 12/82