

(19)



(11)

**EP 2 138 785 A3**

(12)

**EUROPEAN PATENT APPLICATION**

(88) Date of publication A3:  
**22.07.2015 Bulletin 2015/30**

(51) Int Cl.:  
**F25D 17/04<sup>(2006.01)</sup> F25D 23/12<sup>(2006.01)</sup>**

(43) Date of publication A2:  
**30.12.2009 Bulletin 2009/53**

(21) Application number: **09250694.8**

(22) Date of filing: **12.03.2009**

(84) Designated Contracting States:  
**AT BE BG CH CY CZ DE DK EE ES FI FR GB GR HR HU IE IS IT LI LT LU LV MC MK MT NL NO PL PT RO SE SI SK TR**  
Designated Extension States:  
**AL BA RS**

- **Cur, Nihat**  
Saint Joseph, MI 49085 (US)
- **Leclear, Douglas David**  
Benton Harbor, MI 49022 (US)
- **Olivani, Andrea**  
20129 Milan (IT)
- **Vonderhaar, John J.**  
Saint Joseph, MI 49085 (US)
- **Wilcox, Michele E.**  
Stevensville, MI 49127 (US)

(30) Priority: **12.03.2008 US 35775 P**  
**24.12.2008 US 343682**  
**24.12.2008 US 343690**  
**24.12.2008 US 343696**

(74) Representative: **Nicholls, Michael John**  
**J A Kemp**  
**14 South Square**  
**Gray's Inn**  
**London WC1R 5JJ (GB)**

(71) Applicant: **Whirlpool Corporation**  
**Benton Harbor, MI 49022 (US)**

(72) Inventors:  
• **Biotti, Carolina**  
**21040 Vedano Olona (IT)**

**(54) Modified atmosphere for food preservation**

(57) An appliance system including a module (12) removably mounted to an appliance (10), one or more removable gas canisters operably connected to the module, and a food retaining enclosed space (14) operably connected to the module. The one or more gas canisters supply a modified atmosphere in the food retaining enclosed space (14). A method of modifying the atmosphere in a food storage space for food includes the steps of: providing a module (12) capable of being removably engaged to an appliance and typically receiving power from the appliance and at least one removable gas canister; operatively connecting or otherwise engaging the module (12) with the appliance (10); operatively connecting or otherwise engaging the module (12) to a food storage area having an existing atmosphere; and removing at least a portion of the existing atmosphere from the food storage space and replacing it with a modified food storage atmosphere using at least one of the at least one removable gas canisters to supply the modified atmosphere to the food storage area.

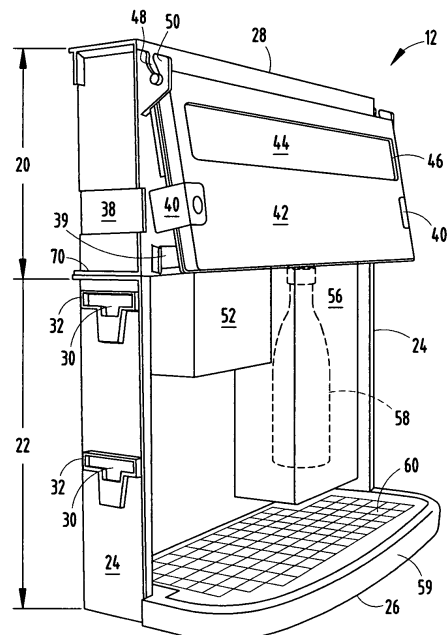

FIG. 1

**EP 2 138 785 A3**



EUROPEAN SEARCH REPORT

Application Number  
EP 09 25 0694

5

10

15

20

25

30

35

40

45

50

55

DOCUMENTS CONSIDERED TO BE RELEVANT			
Category	Citation of document with indication, where appropriate, of relevant passages	Relevant to claim	CLASSIFICATION OF THE APPLICATION (IPC)
X	US 5 046 332 A (HERRMANN FRANZ [ES] ET AL) 10 September 1991 (1991-09-10) * column 1, line 5 - line 14 * * column 2, line 1 - line 62 * * column 3, line 39 - column 6, line 3 * * figures 1-4 *	1,7-10, 12,14 2-6,11, 13,15	INV. F25D17/04 F25D23/12
Y	----- US 6 256 968 B1 (KRISTEN HANNS J [US]) 10 July 2001 (2001-07-10) * abstract * * figures 1-10 *	2-6,13	
Y	----- US 2006/090427 A1 (HAU JOSEPH A [US] ET AL) 4 May 2006 (2006-05-04) * abstract * * figures 1-5 *	11	
Y	----- FR 2 595 583 A1 (SOCAR [FR]) 18 September 1987 (1987-09-18) * page 4, line 1 - page 5, line 23 *	15	
A	----- US 4 055 931 A (MYERS ALBERT H) 1 November 1977 (1977-11-01) * the whole document *	1-15	
The present search report has been drawn up for all claims			TECHNICAL FIELDS SEARCHED (IPC) F25C F25D A23L A23B B65B
Place of search The Hague		Date of completion of the search 29 May 2015	Examiner Correia dos Reis, I
CATEGORY OF CITED DOCUMENTS X : particularly relevant if taken alone Y : particularly relevant if combined with another document of the same category A : technological background O : non-written disclosure P : intermediate document		T : theory or principle underlying the invention E : earlier patent document, but published on, or after the filing date D : document cited in the application L : document cited for other reasons ----- & : member of the same patent family, corresponding document	

2

EPO FORM 1503 03.82 (P04C01)

ANNEX TO THE EUROPEAN SEARCH REPORT  
ON EUROPEAN PATENT APPLICATION NO.

EP 09 25 0694

5

This annex lists the patent family members relating to the patent documents cited in the above-mentioned European search report.  
The members are as contained in the European Patent Office EDP file on  
The European Patent Office is in no way liable for these particulars which are merely given for the purpose of information.

29-05-2015

10

Patent document cited in search report	Publication date	Patent family member(s)	Publication date
US 5046332 A	10-09-1991	DD 299448 A5	16-04-1992
		DE 3924589 C1	20-12-1990
		EP 0411267 A2	06-02-1991
		US 5046332 A	10-09-1991
-----			
US 6256968 B1	10-07-2001	AU 4242400 A	14-11-2000
		EP 1177132 A1	06-02-2002
		JP 2002541031 A	03-12-2002
		US 6256968 B1	10-07-2001
		WO 0061437 A1	19-10-2000
-----			
US 2006090427 A1	04-05-2006	NONE	
-----			
FR 2595583 A1	18-09-1987	NONE	
-----			
US 4055931 A	01-11-1977	AU 512707 B2	23-10-1980
		AU 2742377 A	01-02-1979
		CA 1100354 A1	05-05-1981
		ES 461108 A1	01-06-1978
		GB 1587534 A	08-04-1981
		GB 1587535 A	08-04-1981
		GR 63363 A1	22-10-1979
		IL 52450 A	30-09-1979
		IT 1079775 B	13-05-1985
		JP S5315442 A	13-02-1978
		JP S5596083 A	21-07-1980
		MX 145971 A	27-04-1982
		NZ 184753 A	08-05-1980
US 4055931 A	01-11-1977		
-----			

15

20

25

30

35

40

45

50

55

EPO FORM P/459

For more details about this annex : see Official Journal of the European Patent Office, No. 12/82