

(19)



(11)

EP 2 155 142 B1

(12)

EUROPEAN PATENT SPECIFICATION

(45) Date of publication and mention of the grant of the patent:
25.05.2016 Bulletin 2016/21

(51) Int Cl.:
A61J 1/20^(2006.01)

(21) Application number: **07748575.3**

(86) International application number:
PCT/SE2007/050415

(22) Date of filing: **13.06.2007**

(87) International publication number:
WO 2008/153459 (18.12.2008 Gazette 2008/51)

(54) PRESSURE EQUALIZING DEVICE, RECEPTACLE AND METHOD

DRUCKAUSGLEICHSVORRICHTUNG, BEHÄLTER UND VERFAHREN

DISPOSITIF D'ÉQUILIBRAGE DE LA PRESSION, RÉCIPIENT ET PROCÉDÉ

(84) Designated Contracting States:
AT BE BG CH CY CZ DE DK EE ES FI FR GB GR HU IE IS IT LI LT LU LV MC MT NL PL PT RO SE SI SK TR

(72) Inventor: **HELMERSON, Elisabet**
S-427 36 Billdal (SE)

(43) Date of publication of application:
24.02.2010 Bulletin 2010/08

(74) Representative: **Valea AB**
Box 1098
405 23 Göteborg (SE)

(73) Proprietor: **Carmel Pharma AB**
402 28 Göteborg (SE)

(56) References cited:
WO-A1-00/35517 WO-A1-02/11794
WO-A1-84/04672 US-A1- 2007 106 244

EP 2 155 142 B1

Note: Within nine months of the publication of the mention of the grant of the European patent in the European Patent Bulletin, any person may give notice to the European Patent Office of opposition to that patent, in accordance with the Implementing Regulations. Notice of opposition shall not be deemed to have been filed until the opposition fee has been paid. (Art. 99(1) European Patent Convention).

Description

TECHNICAL FIELD

[0001] The present invention concerns a pressure equalizing device comprising a fluid container, i.e. liquid and/or gas container, for attachment to a receptacle, such as a vial, to permit pressure equalization between the fluid container and the receptacle. The present invention also concerns a receptacle comprising such a pressure equalizing device.

BACKGROUND OF THE INVENTION

[0002] When preparing and administering drugs care has to be taken to minimize, or preferably eliminate the risk of exposing people, such as medical and pharmacological personnel, to toxic substances. Safety boxes, cabinets or isolators are often used to prepare drugs to reduce the risk of toxic substances leaking into breathable air. However, such facilities require a lot of space, they are non-portable and can be expensive to install, maintain and repair.

[0003] Some drugs must be dissolved or diluted before they are administered, which involves transferring a solvent from one container to a sealed vial containing the drug in powder or liquid form, by means of a needle for example. Drugs may be inadvertently released into the atmosphere in gas form or by way of aerosolization, during the withdrawal of the needle from the vial and while the needle is inside the vial if any pressure differential between the interior of the vial and surrounding atmosphere exists.

[0004] This problem may be eliminated or at least minimized by using a pressure equalization device that may be attached to a vial during the preparation of drugs. The pressure equalization device comprises a gas container in communication with the interior of the vial, which ensures that neither an increased pressure nor a vacuum can occur inside the vial when gas or liquid is injected into or withdrawn from the vial. The gas container may be filled with cleaned or sterilized air prior to its use to ensure that the contents of the vial do not become contaminated with air-borne particles such as dust, pollen, mould or bacteria and other undesirable substances.

[0005] US 2007/106244 describes a vial adapter comprising a housing, the housing comprising an expandable chamber to contain a volume, an internal passage in communication with the expandable chamber, at least one opening in communication with the internal passage, and an access member integral with the housing. A hollow spike comprising a proximal end is integral with the housing and a distal end. The spike comprises a vent lumen open at the distal end and a fluid lumen open at the distal end, the vent lumen is in communication with the internal passage and the fluid lumen is in communication with the access member. A first check valve restricts communication from the expandable chamber to the internal

passage, and a second check valve restricts communication from the internal passage to the opening. Methods of reconstituting and/or withdrawing hazardous material using the vial adapter are also described.

SUMMARY OF THE INVENTION

[0006] An object of the present invention is to provide an improved pressure equalizing device comprising a fluid container, i.e. gas and/or liquid container, for attachment to a receptacle, such as a vial, to permit pressure equalization between the fluid container and the receptacle.

This object is achieved by a pressure equalizing device comprising the features of claim 1, which comprises a fluid container and a flow channel that is arranged to provide fluid communication into or out of the fluid container when the pressure equalizing device is attached to the receptacle. The pressure equalizing device also comprises a fluid inlet that contains a one-way valve that permits fluid to flow into the fluid container via said fluid inlet and that prevents fluid from flowing out of the fluid container via said fluid inlet. The pressure equalizing device also comprises filter-receiving means that are arranged to permit fluid flowing into or out of the fluid container to be filtered when the filter-receiving means comprises a filter. The pressure equalizing device equalizes pressure in the fluid container and the receptacle by allowing filtered fluid to flow into or out of the receptacle depending on whether the pressure is temporarily greater in the fluid container or the receptacle. The pressure equalizing device thereby provides a simple, closed system that allows for safe and reliable injection or withdrawal of substances, such as toxic drugs, into or out of a receptacle while at least minimizing, or eliminating the risk of the substances contaminating breathable air.

[0007] According to an embodiment of the invention the filter-receiving means comprises a removable or non-removable filter. As an example, a filter with the mesh size 0.2 μm may be used to remove substantially all particles and micro organisms of that size or larger. The filter may be a sterilizing or aseptisizing filter, such as a particulate air filter, such as a high efficiency particulate air (HEPA) filter to remove gas-borne particles such as dust, pollen, mould or bacteria and thus eliminating or at least reducing the risk of such gas-borne particles from contaminating substances inside the vial. It should be noted that the pressure equalizing device may comprise a plurality of filters of the same type or of different types.

[0008] According to an embodiment of the invention the filter-receiving means are located upstream or downstream of the one-way valve in the fluid inlet, which permits fluid to be filtered as it flows into the fluid container when the filter-receiving means comprises a filter. According to another embodiment of the invention the filter-receiving means are located in the flow channel, which permits fluid to be filtered as it flows out of the fluid container into the receptacle when the filter-receiving means

comprises a filter.

[0009] According to a further embodiment of the invention the fluid container is an air container.

[0010] According to another embodiment of the invention the fluid inlet is arranged to be in communication with ambient, i.e. non-sterilized air. Since ambient air can be cleaned on site using a sterilizing or asepticizing filter in the pressure equalizing device, neither a sterile environment, nor extra equipment, nor a supply of clean air is necessary to fill the fluid container with cleaned air. The pressure equalizing device according to the present invention may therefore be filled or replenished with cleaned fluid almost anywhere, in a simple manner and at low cost.

[0011] According to a further embodiment of the invention the fluid container comprises a flexible portion, such as a bladder, i.e. a portion comprising a flexible or expandable material, whereby the volume of said portion can be increased by drawing fluid into the fluid container and decreased by withdrawing fluid from the fluid container. The fluid container may however be at least partly constituted of a rigid, non-compressible material.

[0012] According to an embodiment of the invention the one-way valve is integrally formed with the filter-receiving means or a filter.

[0013] According to another embodiment of the invention the filter-receiving means is removable from the fluid container.

[0014] According to a further embodiment of the invention the pressure equalizing device comprises connecting means, such as a bayonet coupling, luer lock or snap fit mechanism, for attachment of the pressure equalizing device to an injector such as a syringe and/or connecting means, such as a snap fit mechanism for attachment of the pressure equalizing device to a receptacle.

[0015] According to an embodiment of the invention at least part of the fluid container is integrally formed with the connecting means, from the same material for example, whereby the material may be a thermoplastic material, such as polyethylene or polypropylene; acrylonitrile butadiene styrene (ABS), polycarbonate, polyester or any other suitable material.

[0016] According to another embodiment of the invention the fluid container is detachable from the connecting means.

[0017] The present invention also concerns a receptacle that comprises a pressure equalizing device according to any of the embodiments of the invention.

[0018] According to an embodiment of the invention at least part of the pressure equalizing device is integrally formed with at least one component of the receptacle, such as its cap or sealing means.

[0019] The pressure equalizing device according to the present invention is intended particularly, but not exclusively for use as a pressure equalizing device during the preparation or administration of drugs.

BRIEF DESCRIPTION OF THE DRAWINGS

[0020] The present invention will hereinafter be further explained by means of non-limiting examples with reference to the appended figures where;

Figure 1 shows a pressure equalizing device according to an embodiment of the invention prior to attachment to a vial,

Figure 2 shows a pressure equalizing device according to an embodiment of the invention, after attachment to attachment to a vial,

Figure 3 shows part of a fluid container according to a first embodiment of the invention,

Figures 4 & 5 show part of a pressure equalizing device according to a second embodiment of the invention,

Figures 6 & 7 show part of a fluid container according to a third embodiment of the invention,

Figures 8-10 show part of a pressure equalizing device according to a fourth embodiment of the invention, and

Figures 11-13 show part of a pressure equalizing device according to a fifth embodiment of the invention.

[0021] It should be noted that the drawings have not been drawn to scale and that the dimensions of certain features have been exaggerated for the sake of clarity.

DETAILED DESCRIPTION OF EMBODIMENTS

[0022] Figure 1 shows a pressure equalizing device 10 according to an embodiment of the invention prior to being attached to a vial 12 containing a solid, liquid or gaseous pharmaceutical, biological or veterinary substance. The vial 12 is sealed by means of a cap 14 and/or an elastomeric stopper or membrane. The pressure equalizing device 10 comprises a gas container 16 having a variable volume. The gas container 16 comprises a first portion 16a, such as a plastic parabola coupled to the main body of the pressure equalizing device 10, which comprises a relatively rigid material and a second portion 16b comprising a relatively flexible material, such as a thin, transparent plastic film that is attached to the first portion 16a in a gastight manner. For example, the gas container 16 can be designed as a bellows which is compressible and extendable. The volume of the gas container 16 can thereby be increased and decreased. Although the device illustrated in figure 1 comprises a partly compressible gas container 16, in another embodiment of the invention the gas container 16 can comprise a cyl-

inder and a piston arranged therein so as to enable the volume of the gas container to be changed.

[0023] Alternatively, the gas container 16 could be constituted by bellows that are manually expandable and contractible. The gas container 16 illustrated in figure 1 is shown in a fully inflated state. The thick dotted line in figure 2 illustrates the position of the flexible portion 16b when the gas container 16 is in an evacuated and thus fully deflated state.

[0024] The gas container 16, which may have a volume of 1 cm³ or less, up to 1 litre or more, depending on the application or size of the receptacle, comprises at least one gas inlet 20 containing a one-way valve and filter-receiving means. The pressure equalizing device 10 comprises connecting means 22, such as a snap fit mechanism for attaching the pressure equalizing device 10 to the neck of a vial 12, which is 1-4 cm in diameter for example and a volume of 50 cm³, whereby the volume of the gas container may be 50 cm³ in its fully inflated state. The pressure equalizing device 10 may of course be dimensioned to be attached to receptacles of any size and volume. The pressure equalizing device 10 also comprises a flow channel 18 that is arranged to provide gas communication between the gas container 16 and the interior of the vial 12 when the pressure equalizing device 10 is connected to the vial 12. Figure 1 also shows a syringe 26 that may be used to inject fluid into the vial 12 or to withdraw fluid therefrom.

[0025] Figure 2 shows the pressure equalizing device 10 shown in figure 1 when it has been detachably or non-detachably attached to the vial 12 and when the needle 26a of the syringe 26 has been inserted through the pressure equalizing device 10 into the interior of the vial 12. As the fluid is injected into the vial 12 or withdrawn from the vial 12, the flow channel 18 of the pressure equalizing device permits gas to flow from the interior of the vial 12 into the gas container 16 or from the gas container 16 to the vial 12, and thereby equalizes the pressure in the interior of the vial 12 and in the gas container 16. Gas may enter the gas container 16 via the fluid inlet 20, however gas cannot exit the gas container 16. This eliminates, or at least reduces the risk of any substance inside the vial 12 being released into the atmosphere in gas form or by way of aerosolization during the insertion or withdrawal of the needle 26a from vial 12 or while the needle 26a is inserted in the vial 12. It also eliminates, or reduces the risk of the vial 12 deforming due to the increased pressure inside the vial 12, whereby such deformation may cause leakage of the vial's contents due to separation of the vial's cap 14 from the vial's walls for example.

[0026] Figure 3 shows the rigid, incompressible part 16a of the gas container 16 shown in figures 1 and 2. This part 16a of the gas container comprises the gas inlet 20 that contains a one-way valve 28 that permits gas to flow into the gas container 16 via the gas inlet 20 and that prevents gas from flowing out of the gas container 16 via the gas inlet 20. The gas inlet 20 also comprises

filter-receiving means 30 that are located upstream of the one-way valve 28. The gas inlet 20 is arranged to be in communication with ambient air. When a filter is placed in the filter-receiving means 30 ambient air is filtered as it flows into the gas container 16. The filter may be any suitable commercially available filter, such as a particulate air filter having a pore size of 0.2 μm. In the illustrated embodiment the one-way valve 28 is integrally formed with filter-receiving means 30. This integrated unit may be detachable or non-detachable from the gas container 16. The gas container 16 also comprises a flow channel 18 that provides a gas communication channel into and out of the gas container 16.

[0027] The embodiment illustrated in figure 3 includes an integrated one-way valve 28 and filter-receiving means 30 unit that is slidably mounted in the plastic parabola 16a of the gas container. The one-way valve 28 comprises an elastic sheath 28a that is arranged to cover an opening 28b and to uncover the opening 28b in its open position. When the pressure outside the gas container 16 exceeds the pressure inside the gas container 16, the integrated one-way valve 28 and filter-receiving means 30 unit is pushed radially inwards in a direction towards the interior of the gas container 16, which causes the elastic sheath 28a to abut against a stopper 28c and retract, uncovering the opening 28b and allowing filtered air into the gas container 16. Conversely, when the pressure inside the gas container 16 exceeds the pressure outside the gas container 16 the integrated one-way valve 28 and filter-receiving means 30 unit is arranged to be pushed radially outwards in a direction out of the gas container 16, whereby the elastic sheath 28a extends and covers the opening 28b preventing any more gas from entering the gas container 16 via the air inlet 20. The one way valve 28 is arranged to draw ambient air through the filter 30 and out of the opening 28b into the gas container 16 when the pressure inside the gas container 16 falls below a predetermined pressure, such as atmospheric pressure in order to keep the pressure inside the vial 12 in equilibrium with the pressure on the exterior of the vial 12. Alternatively, the one way valve 28 could be arranged to be opened and closed manually.

[0028] Figures 4 and 5 show part of a pressure equalizing device 10 according to a second embodiment of the invention. The pressure equalizing device comprises connecting means 22 for attachment to a receptacle and connecting means 23, namely a bayonet coupling, for attachment to an injector, such as a syringe, and a gas container 16 comprising a plastic parabola 16a and a flexible portion (not shown) that is attached to the plastic parabola 16a. A filter may be placed in the filter-receiving means 30 to filter gas entering the gas container 16 via the air inlet 20 (that is hidden behind the filter-receiving means 30 in figures 4 and 5).

[0029] The filter-receiving means 30 are either integrally formed with the plastic parabola 16a of the gas container 16, by a blow moulding or vacuum forming process for example, or are attached to the inner surface

of the plastic parabola 16a, by a continuous welding process, such as ultrasound welding, for example. Ultrasound is used to generate internal friction in the plastic of the parabola 16a and the filter-receiving means 30 and thereby heat the parabola 16a and the filter-receiving means 30. The heated surfaces are then joined together by application of pressure. A filter may be permanently attached to the filter-receiving means 30 using ultrasound welding.

[0030] The filter and filter-receiving means 30 should be arranged to ensure that a flexible portion is substantially uniformly inflated so that no part of it is excessively stretched during the inflation thereof. The filter may, for example, be arranged at an angle to the direction of incoming gas as shown in figures 4 and 5, rather than being arranged perpendicularly to the direction of incoming gas. A second filter-receiving means may be placed in the flow channel 18 to enable fluid passing between the vial 12 and the gas container 16 to be filtered.

[0031] Figure 6 shows an exploded view of part of a pressure equalizing device 10 according to a third embodiment of the invention. The gas container 16 comprises a parabola 16a and a flexible portion 16b comprising a thin transparent film. The gas container 16 comprises an air inlet 20 and a one-way valve 28 is located in the air inlet 20. Figure 7 shows the pressure equalizing device 10 of figure 6 when in use. Gas flows into the gas container 16 in the direction of the arrows in figure 7, namely through the openings in part 24 of the gas container 16, through a filter 34 into the air inlet 20 via radial channels and past the one-way valve 28 into the interior of the gas container 16. The part 24 comprising the openings in the illustrated embodiment may be arranged to be removable from the gas container 16 or it may be fixedly attached thereto, by means of adhesion or welding for example. Figure 7 shows that filter-receiving means 30 may be placed at the mouth of the flow channel 18 that provides gas communication into or out of the gas container and/or at any other position along the flow channel 18.

[0032] Figures 8-10 show part of a pressure equalizing device 10 according to a fourth embodiment of the invention. The pressure equalizing device 10 comprises a gas container comprising a parabola 16a and means 22 for connecting the pressure equalizing device 10 to an receptor. The gas container 16 may be detachable from the connecting means 22. The gas container 16 is for example attached to the connecting means 22 by means of a bayonet coupling or any other releasable coupling means. Filter-receiving means 30 are placed in between the gas container 16 and the connecting means 22.

[0033] Figures 11-13 show part of a pressure equalizing device 10 according to a fifth embodiment of the invention. The pressure equalizing device 10 comprises a parabola 16a and connecting means 23 for attaching the pressure equalizing device 10 to an injector, such as a syringe. The parabola 16a is integrally formed with the connecting means 22 and 23 in the illustrated embodi-

ment. The pressure equalizing device 10 comprises an insert 36 comprising filter-receiving means 30 and a one-way valve 28. The insert 36 is removably or non-removably attached to the inside of the parabola 16a and may be provided with guiding means, to facilitate positioning of the filter-receiving means 30 in the flow channel 18 and/or the one-way valve 28 in the air inlet 20.

[0034] Further modifications of the invention within the scope of the claims would be apparent to a skilled person. For example, the gas container may be of any shape and size and may be located in any suitable position with respect to a receptacle when a pressure equalizing device is attached to a receptacle.

Claims

1. Pressure equalizing device (10) comprising a fluid container (16) for attachment to a receptacle (12), such as a vial, to permit pressure equalization between the fluid container (16) and the receptacle (12), whereby the pressure equalizing device (10) comprises

- a flow channel (18) that is arranged to provide fluid communication into or out of the fluid container (16) when the pressure equalizing device (10) is attached to the receptacle (12),

characterized in that it comprises

- a fluid inlet (20) that contains a one-way valve (28) that permits fluid to flow into the fluid container (16) via said fluid inlet (20) and that prevents fluid from flowing out of the fluid container (16) via said fluid inlet (20), and
- filter-receiving means (30) that are arranged to permit fluid flowing into or out of the fluid container (16), depending on whether the pressure is temporarily greater in the fluid container or the receptacle, J to be filtered when the filter-receiving means (30) comprises a filter (34).

2. Pressure equalizing device (10) according to any claim 1, **characterized in that** the filter-receiving means (30) comprises a removable or non-removable filter (34).

3. Pressure equalizing device (10) according to claim 2, **characterized in that** the filter (34) is a sterilizing or aseptizing filter, such as a particulate air filter, such as a high efficiency particulate air (HEPA) filter.

4. Pressure equalizing device (10) according any of the preceding claims, **characterized in that** the filter-receiving means (30) are located upstream or downstream of the one-way valve (28) in the fluid inlet (20), which permits fluid to be filtered as it flows into

the fluid container (16) when the filter-receiving means (30) comprises a filter (34).

5. Pressure equalizing device (10) according to any of claims 1-3, **characterized in that** the filter-receiving means (30) are located in the flow channel (18), which permits fluid to be filtered as it flows out of the fluid container (16) into the receptacle (12) when the filter-receiving means (30) comprises a filter (34). 5
6. Pressure equalizing device (10) according to any of the preceding claims, **characterized in that** the fluid container (16) is an air container. 10
7. Pressure equalizing device (16) according to any of the preceding claims, **characterized in that** the fluid inlet (20) is arranged to be in communication with ambient air. 15
8. Pressure equalizing device (10) according to any of the preceding claims, **characterized in that** the fluid container (16) comprises a flexible portion (16b). 20
9. Pressure equalizing device (16) according to any of the preceding claims, **characterized in that** the one-way valve (28) is integrally formed with the filter-receiving means (30) or with a filter (34). 25
10. Pressure equalizing device (10) according to any of the preceding claims, **characterized in that** the filter-receiving means (30) are detachable from the fluid container (10). 30
11. Pressure equalizing device (10) according to any of the preceding claims, **characterized in that** it comprises connecting means (22) for attachment of the pressure equalizing device (10) to a receptacle (12) and/or connecting means (23) for attachment of the pressure equalizing device (10) to an injector, such as a syringe. 35
12. Pressure equalizing device (10) according to claim 11, **characterized in that** at least part of the fluid container (16a) is integrally formed with the connecting means (22, 23). 40
13. Pressure equalizing device (10) according to claim 11, **characterized in that** the fluid container (16) is detachable from the connecting means (22, 23). 45
14. Receptacle, **characterized in that** it comprises a pressure equalizing device (10) according to any of claims 1-13. 50
15. Receptacle according to claim 14, **characterized in that** at least part of the pressure equalizing device (10) is integrally formed with at least one component of the receptacle (12). 55

16. Use of the pressure equalizing device (10) according to any of claims 1-13 as a pressure equalizing device during the preparation or administration of drugs.

Patentansprüche

1. Druckausgleichsvorrichtung (10), welche einen Fluidbehälter (16) zur Anbringung an einem Gefäß (12) wie beispielsweise einer Phiole aufweist, um so einen Druckausgleich zwischen dem Fluidbehälter (16) und dem Gefäß (12) zu ermöglichen, wobei die Druckausgleichsvorrichtung (10) folgendes umfasst:

- einen Strömungskanal (18), der so angeordnet ist, dass er für eine Strömungsverbindung in den Fluidbehälter (16) und aus diesem heraus sorgt, wenn die Druckausgleichsvorrichtung (10) an dem Gefäß (12) angebracht ist,

dadurch gekennzeichnet, dass sie folgendes aufweist:

- einen Fluideinlass (20), der ein Rückschlagventil (28) enthält, welches ein Fluid über den Fluideinlass (20) in den Fluidbehälter (16) einströmen lässt, und welches verhindert, dass ein Fluid über den Fluideinlass (20) aus dem Fluidbehälter (16) ausfließt, und
- eine Filteraufnahmeeinrichtung (30), die so angeordnet ist, dass sie ein Fluid zur Filterung dann, wenn die Filteraufnahmeeinrichtung (30) einen Filter (34) enthält, in den Fluidbehälter einfließen oder aus diesem ausfließen lässt, je nachdem, ob der Druck zeitweise in dem Fluidbehälter oder dem Gefäß größer ist.

2. Druckausgleichsvorrichtung (10) nach Anspruch 1, **dadurch gekennzeichnet, dass** die Filteraufnahmeeinrichtung (30) einen herausnehmbaren oder nicht-herausnehmbaren Filter (34) aufweist. 40
3. Druckausgleichsvorrichtung (10) nach Anspruch 2, **dadurch gekennzeichnet, dass** der Filter (34) ein Sterilisierfilter oder aseptisch machender Filter, beispielsweise ein Feinstaub-Luftfilter wie z.B. ein Schwebstofffilter, ist. 45
4. Druckausgleichsvorrichtung (10) nach einem der vorhergehenden Ansprüche, **dadurch gekennzeichnet, dass** sich die Filteraufnahmeeinrichtung (30) anströmseitig oder abströmseitig von einem Rückschlagventil (28) in dem Fluideinlass (20) befindet, wodurch eine Filtrierung der Flüssigkeit beim Einfließen in den Fluidbehälter (16) ermöglicht wird, wenn die Filteraufnahmeeinrichtung (30) einen Filter (34) enthält. 55

5. Druckausgleichsvorrichtung (10) nach einem der Ansprüche 1 bis 3, **dadurch gekennzeichnet, dass** sich die Filteraufnahmeeinrichtung (30) in dem Strömungskanal (18) befindet, wodurch eine Filtrierung der Flüssigkeit beim Ausfließen aus dem Fluidbehälter (16) in das Gefäß (12) ermöglicht wird, wenn die Filteraufnahmeeinrichtung (30) einen Filter (34) enthält.
6. Druckausgleichsvorrichtung (10) nach einem der vorhergehenden Ansprüche, **dadurch gekennzeichnet, dass** der Fluidbehälter (16) ein Luftbehälter ist.
7. Druckausgleichsvorrichtung (16) nach einem der vorhergehenden Ansprüche, **dadurch gekennzeichnet, dass** der Fluideinlass (20) so angeordnet ist, dass er in Strömungsverbindung mit der Umgebungsluft steht.
8. Druckausgleichsvorrichtung (10) nach einem der vorhergehenden Ansprüche, **dadurch gekennzeichnet, dass** der Fluidbehälter (16) einen elastischen Abschnitt (16b) aufweist.
9. Druckausgleichsvorrichtung (16) nach einem der vorhergehenden Ansprüche, **dadurch gekennzeichnet, dass** das Rückschlagventil (28) einstückig mit der Filteraufnahmeeinrichtung (30) oder mit einem Filter (34) ausgebildet ist.
10. Druckausgleichsvorrichtung (10) nach einem der vorhergehenden Ansprüche, **dadurch gekennzeichnet, dass** die Filteraufnahmeeinrichtung (30) von dem Fluidbehälter (10) lösbar ist.
11. Druckausgleichsvorrichtung (10) nach einem der vorhergehenden Ansprüche, **dadurch gekennzeichnet, dass** sie Verbindungsmittel (22) zur Anbringung der Druckausgleichsvorrichtung (10) an einem Gefäß (12) und/oder Verbindungsmittel (23) zur Anbringung der Druckausgleichsvorrichtung (10) an einer Einspritzvorrichtung wie beispielsweise einer medizinischen Spritze aufweist.
12. Druckausgleichsvorrichtung (10) nach Anspruch 11, **dadurch gekennzeichnet, dass** zumindest ein Teil des Fluidbehälters (16a) einstückig mit den Verbindungsmitteln (22, 23) ausgebildet ist.
13. Druckausgleichsvorrichtung (10) nach Anspruch 11, **dadurch gekennzeichnet, dass** der Fluidbehälter (16) von den Verbindungsmitteln (22, 23) lösbar ist.
14. Gefäß, **dadurch gekennzeichnet, dass** er eine Druckausgleichsvorrichtung (10) nach einem der Ansprüche 1 bis 13 umfasst.

5

10

15

20

25

30

35

40

45

50

55

15. Gefäß nach Anspruch 14, **dadurch gekennzeichnet, dass** zumindest ein Teil der Druckausgleichsvorrichtung (10) einstückig mit mindestens einem Bauteil des Behälters (12) ausgebildet ist.

16. Verwendung des Druckausgleichsbehälters (10) nach einem der Ansprüche 1 bis 13 als Vorrichtung zum Druckausgleich während der Herstellung oder Verabreichung von Medikamenten.

Revendications

1. Dispositif d'équilibrage de pression (10) comprenant un conteneur de fluide (16) destiné à être fixé sur un réceptacle (12), tel qu'une fiole, afin de permettre l'équilibrage de pression entre le conteneur de fluide (16) et le réceptacle (12), de telle sorte que le dispositif d'équilibrage de pression (10) comprend :

- un canal d'écoulement (18) qui est agencé de manière à assurer une communication fluide vers le conteneur de fluide (16) ou à partir de ce dernier lorsque le dispositif d'équilibrage de pression (10) est fixé sur le réceptacle (12),

caractérisé en ce qu'il comprend :

- une entrée de fluide (20) qui contient un clapet (28) qui permet l'écoulement du fluide vers le premier conteneur de fluide (16) par l'intermédiaire de ladite entrée de fluide (20) et qui empêche le fluide de s'écouler du conteneur de fluide (16) par l'intermédiaire de ladite entrée de fluide (20), et
- des moyens de réception de filtre (30) qui sont agencés de manière à permettre le filtrage du fluide entrant dans le conteneur de fluide (16) ou sortant de celui-ci, en fonction du fait que la pression est temporairement supérieure dans le conteneur de fluide ou le réceptacle, lorsque le moyen de réception de filtre (30) comprend un filtre (34).

2. Dispositif d'équilibrage de pression (10) selon la revendication 1, **caractérisé en ce que** les moyens de réception de filtre (30) comprennent un filtre amovible ou non amovible (34).

3. Dispositif d'équilibrage de pression (10) selon la revendication 2, **caractérisé en ce que** le filtre (34) est un filtre de stérilisation ou d'aseptisation, tel qu'un filtre de particules aériennes, tel qu'un filtre de particules aériennes à haute efficacité (HEPA).

4. Dispositif d'équilibrage de pression (10) selon l'une quelconque des revendications précédentes, **caractérisé en ce que** les moyens de réception de filtre

- (30) sont situés en amont ou en aval du clapet (28) sur l'entrée de fluide (20), ce qui permet le filtrage du fluide à mesure qu'il s'écoule dans le conteneur de fluide (16) lorsque les moyens de réception de filtre (30) comprennent un filtre (34).
- 5
5. Dispositif d'équilibrage de pression (10) selon l'une quelconque des revendications 1 à 3, **caractérisé en ce que** les moyens de réception de filtre (30) sont situés sur le canal d'écoulement (18), ce qui permet le filtrage du fluide à mesure qu'il s'écoule hors du conteneur de fluide (16) dans le réceptacle (12) lorsque les moyens de réception de filtre (30) comprennent un filtre (34).
- 10
6. Dispositif d'équilibrage de pression (10) selon l'une quelconque des revendications précédentes, **caractérisé en ce que** le conteneur de fluide (16) est un conteneur d'air.
- 15
7. Dispositif d'équilibrage de pression (16) selon l'une quelconque des revendications précédentes, **caractérisé en ce que** l'entrée de fluide (20) est agencée de manière à être en communication avec l'air ambiant.
- 20
8. Dispositif d'équilibrage de pression (10) selon l'une quelconque des revendications précédentes, **caractérisé en ce que** le conteneur de fluide (16) comprend une partie flexible (16b).
- 25
9. Dispositif d'équilibrage de pression (16) selon l'une quelconque des revendications précédentes, **caractérisé en ce que** le clapet (28) est formé de manière unitaire avec les moyens de réception de filtre (30) ou avec un filtre (34).
- 30
10. Dispositif d'équilibrage de pression (10) selon l'une quelconque des revendications précédentes, **caractérisé en ce que** les moyens de réception de filtre (30) peuvent être séparés du conteneur de fluide (10).
- 35
11. Dispositif d'équilibrage de pression (10) selon l'une quelconque des revendications précédentes, **caractérisé en ce qu'il** comprend un moyen de raccordement (22) afin d'assurer la fixation du dispositif d'équilibrage de pression (10) sur un réceptacle (12) et/ou des moyens de raccordement (23) destinés à assurer la fixation du dispositif d'équilibrage de pression (10) sur un injecteur, tel qu'une seringue.
- 40
- 45
- 50
12. Dispositif d'équilibrage de pression (10) selon la revendication 11, **caractérisé en ce qu'au moins** une partie du conteneur de fluide (16a) est formée de manière unitaire avec les moyens de raccordement (22, 23).
- 55
13. Dispositif d'équilibrage de pression (10) selon la revendication 11, **caractérisé en ce que** le conteneur de fluide (16) peut être séparé des moyens de raccordement (22, 23).
14. Réceptacle, **caractérisé en ce qu'il** comprend un dispositif d'équilibrage de pression (10) selon l'une quelconque des revendications 1 à 13.
15. Réceptacle selon la revendication 14, **caractérisé en ce qu'au moins** une partie du dispositif d'équilibrage de pression (10) est formée de manière unitaire avec au moins un composant du réceptacle (12).
16. Utilisation du dispositif d'équilibrage de pression (10) selon l'une quelconque des revendications 1 à 13, en tant que dispositif d'équilibrage de pression pendant la préparation ou de l'administration de médicaments.

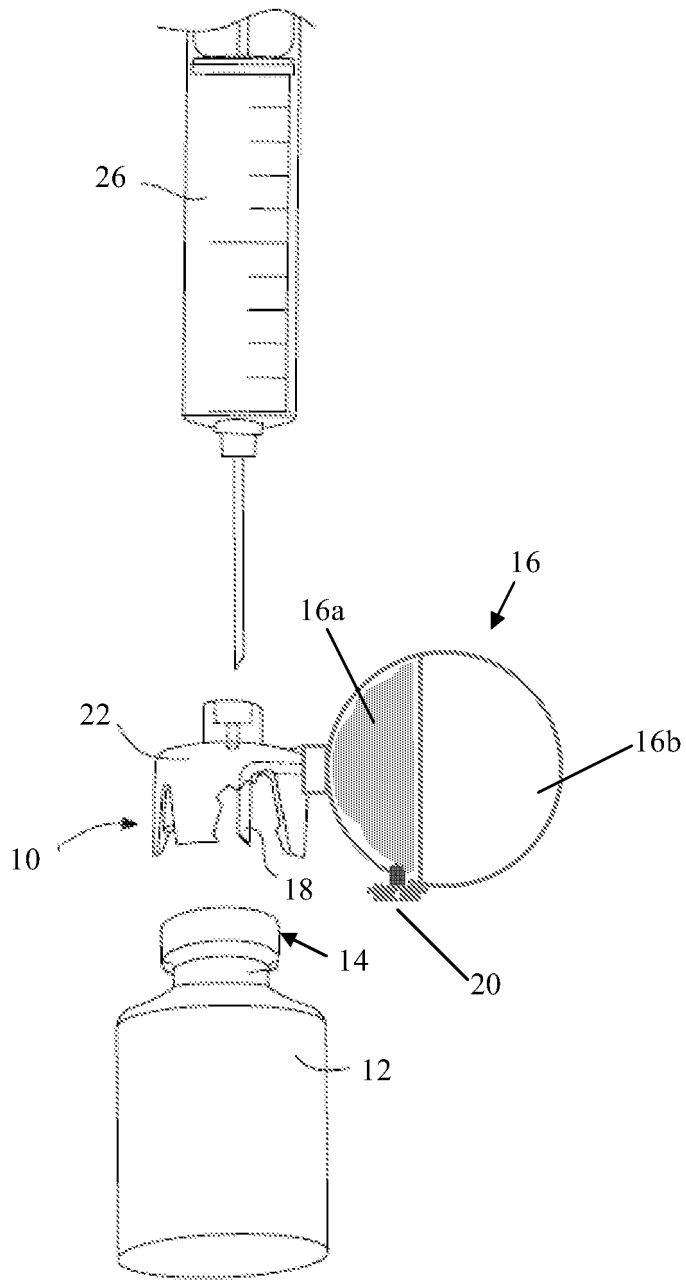

Fig. 1

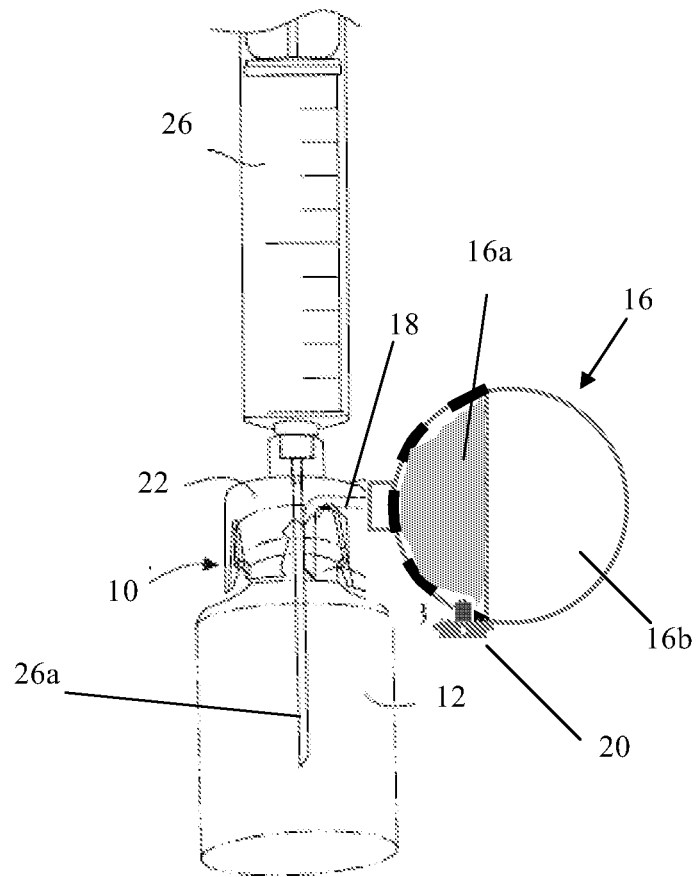

Fig. 2

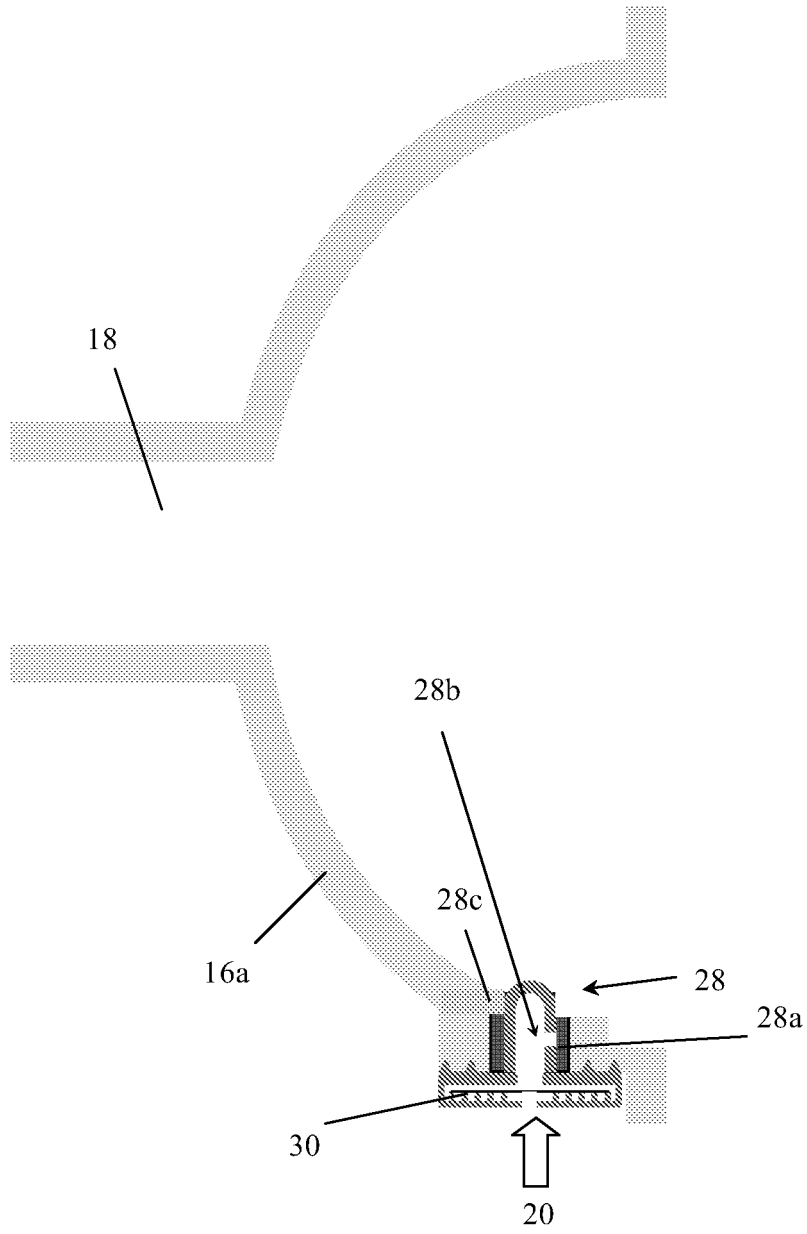

Fig. 3

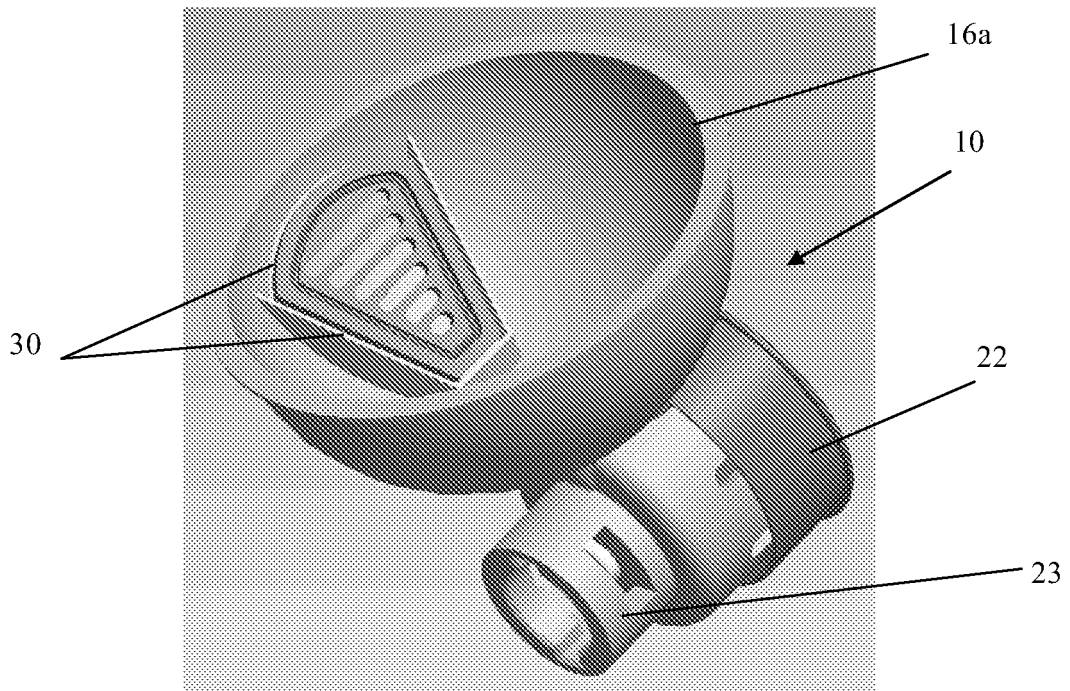

Fig. 4

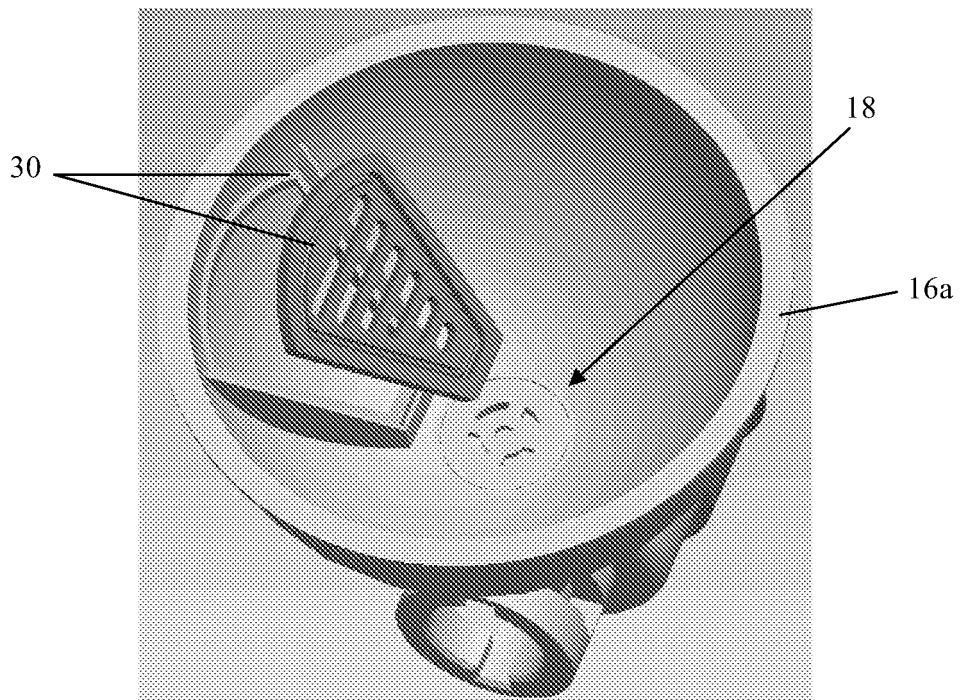

Fig. 5

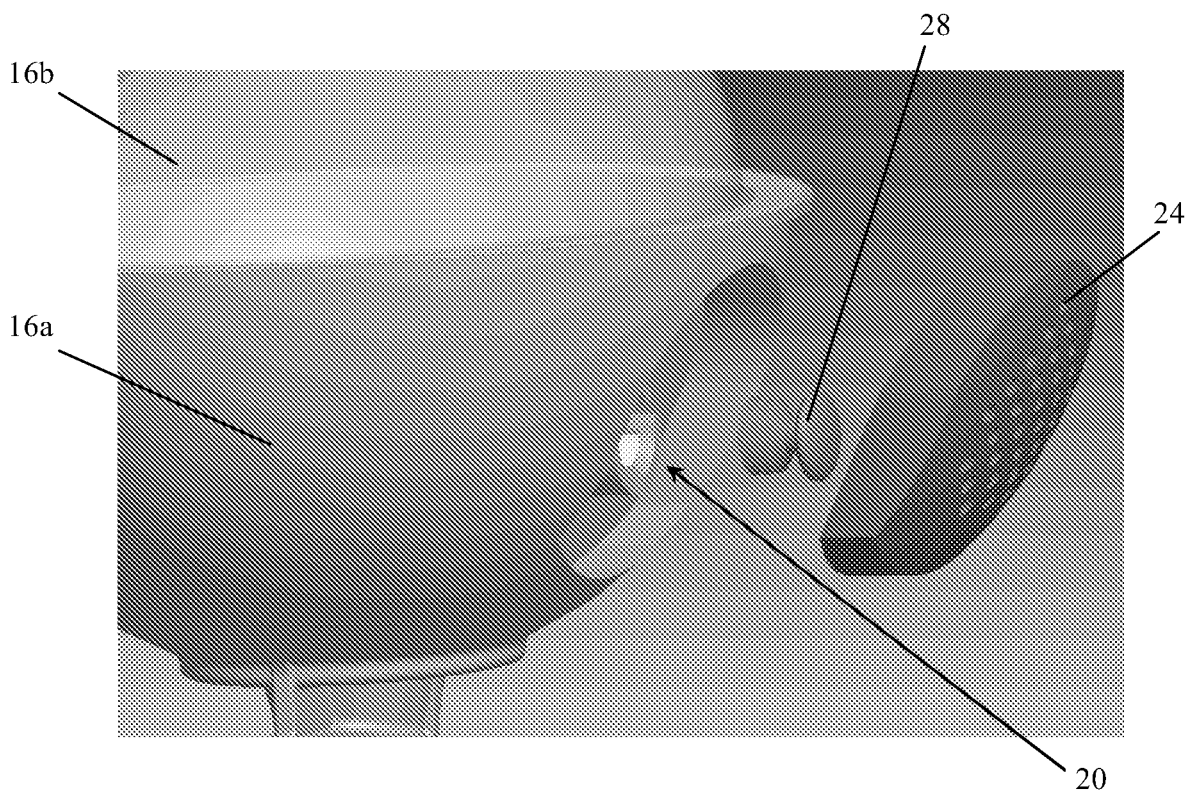

Fig. 6

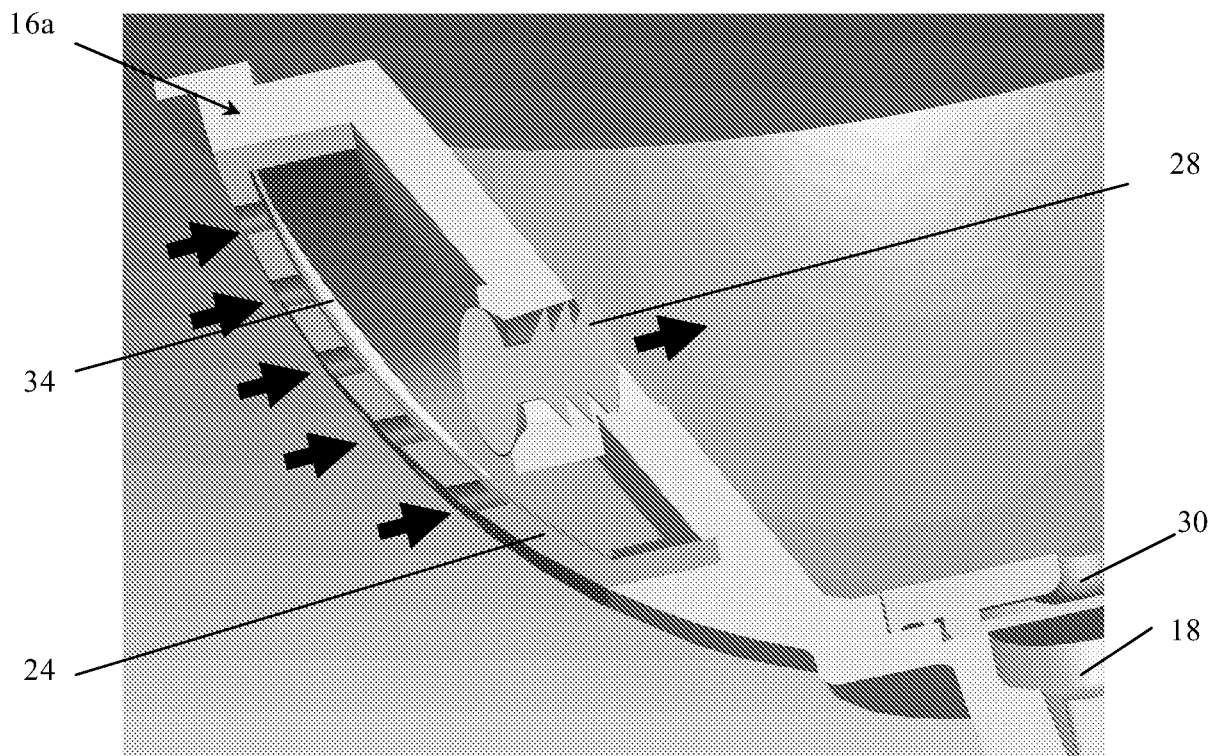

Fig. 7

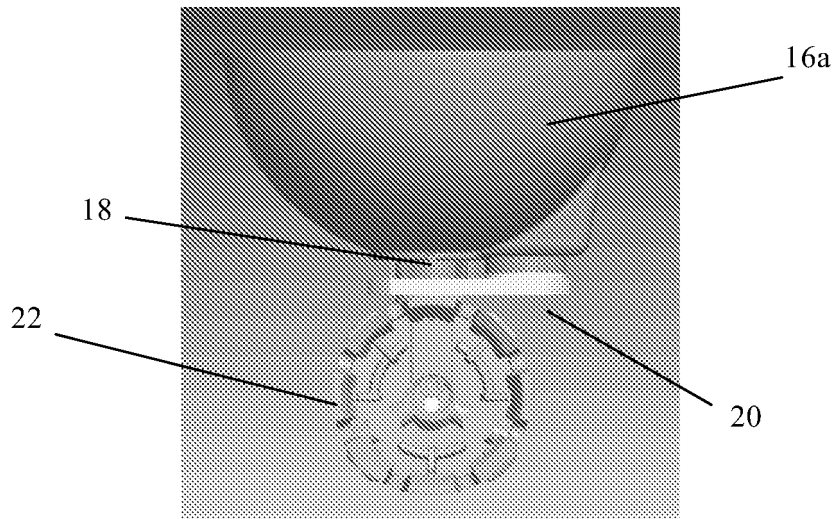

Fig. 8

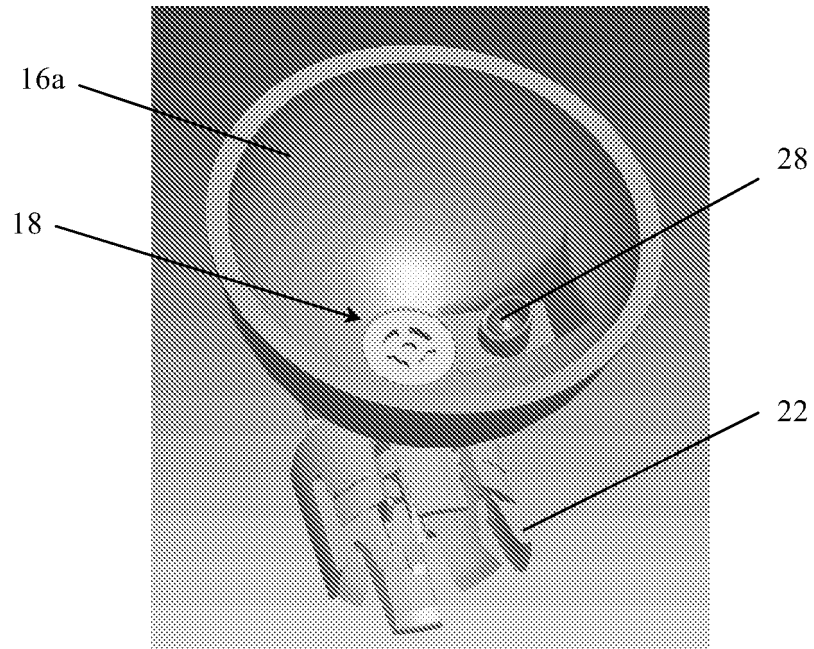

Fig. 9

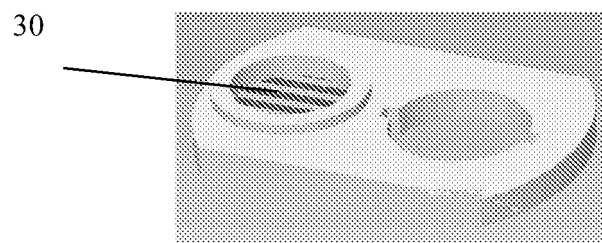
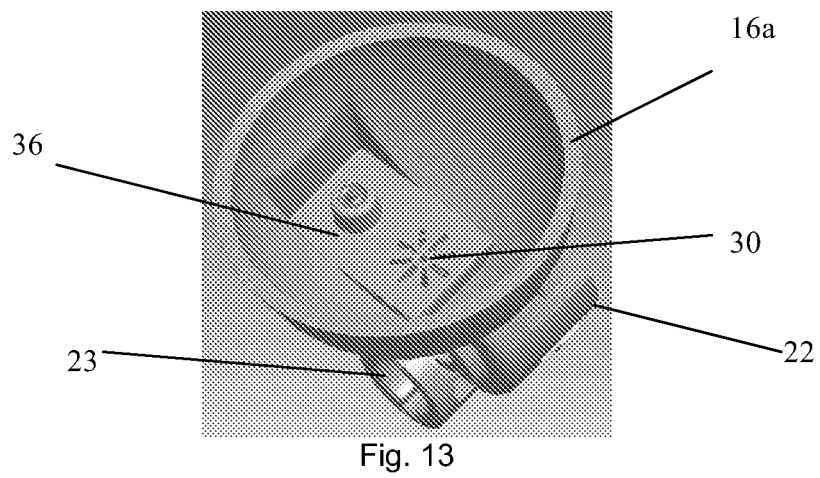
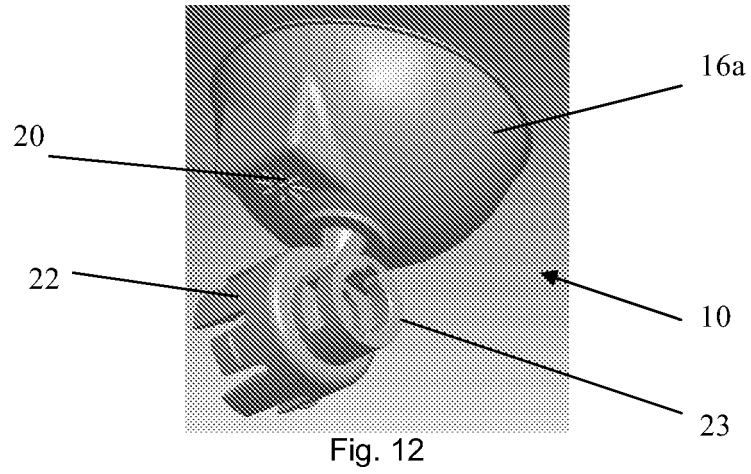
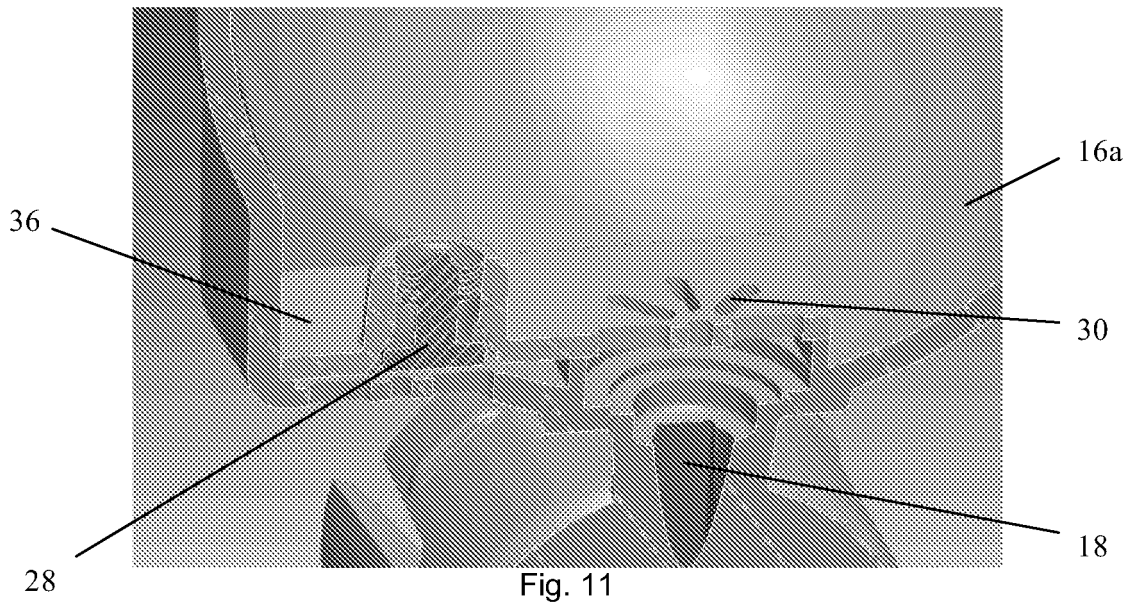

Fig. 10



REFERENCES CITED IN THE DESCRIPTION

This list of references cited by the applicant is for the reader's convenience only. It does not form part of the European patent document. Even though great care has been taken in compiling the references, errors or omissions cannot be excluded and the EPO disclaims all liability in this regard.

Patent documents cited in the description

- US 2007106244 A [0005]