

(19)



(11)

EP 2 163 831 B1

(12)

EUROPEAN PATENT SPECIFICATION

(45) Date of publication and mention of the grant of the patent:
07.11.2018 Bulletin 2018/45

(51) Int Cl.:
F24F 1/00 (2011.01)

(21) Application number: **09014233.2**

(22) Date of filing: **27.06.2005**

(54) **Air conditioner**

Klimaanlage

Climatiseur

(84) Designated Contracting States:
ES FR HU IT

(30) Priority: **30.09.2004 JP 2004285684**
30.09.2004 JP 2004285809

(43) Date of publication of application:
17.03.2010 Bulletin 2010/11

(62) Document number(s) of the earlier application(s) in accordance with Art. 76 EPC:
05765087.1 / 1 795 819

(73) Proprietors:

- **Toshiba Carrier Corporation**
Tokyo 105-0023 (JP)
- **Advanced Air-Conditioning Research and Development Center Co., Ltd.**
Fuji-shi, Shizuoka 416-8521 (JP)
- **Sanyo Electric Co., Ltd.**
Osaka 570-8677 (JP)

(72) Inventors:

- **Koga, Seiichi**
Ota-shi
Gunma 373-0806 (JP)

- **Ogura, Nobuhiro**
Kiryu-shi
Gunma 376-0034 (JP)
- **Kunisada, Mitsuo**
Ashikaga-shi
Tochigi 326-0006 (JP)
- **Hamada, Yoshinobu**
Kawasaki-shi
Kanagawa 215-0017 (JP)
- **Yoshida, Jin**
Ora-gun
Gunma 370-0523 (JP)
- **Iijima, Morinobu**
Konosu-shi
Saitama 365-0045 (JP)
- **Makino, Masazumi**
Ora-gun
Gunma 370-0511 (JP)

(74) Representative: **Glawe, Delfs, Moll**
Partnerschaft mbB von
Patent- und Rechtsanwälten
Postfach 13 03 91
20103 Hamburg (DE)

(56) References cited:
EP-A- 0 834 704 JP-A- 2000 171 053
JP-A- 2001 235 177 JP-U- 7 022 344

EP 2 163 831 B1

Note: Within nine months of the publication of the mention of the grant of the European patent in the European Patent Bulletin, any person may give notice to the European Patent Office of opposition to that patent, in accordance with the Implementing Regulations. Notice of opposition shall not be deemed to have been filed until the opposition fee has been paid. (Art. 99(1) European Patent Convention).

Description**Technical Field**

[0001] The present invention relates to an air conditioner.

Background Art

[0002] There has been hitherto known an in-ceiling mount type air conditioner that is mounted in the ceiling of a room to be air-conditioned and has a unit main body (the main body of the air conditioner) containing a heat exchanger and an air blower accommodated in a substantially box-shaped housing. In this type of in-ceiling mount type air conditioner, a face panel having an air blowing port is secured to the lower surface side of the unit main body by screws (for example. See Patent Document 1) . Furthermore, there are also known in-ceiling mount type air conditioners in which a duct port is provided on the side surface of the unit main body, and air-conditioned air is blown from the air blowing port through an air blowing duct connected to the duct port. In some of this type of air conditioners each having the air blowing duct, a rotatable disc is disposed in the duct port and the air blowing amount to the air blowing duct is adjustable by the disc (for example, see Patent Document 2) .

Patent Document 1: JP-A-2003-194394

Patent Document 2: JP-UM-A-7-22344

JP 7022344 U discloses an air conditioner with plural duct-planned ports on a side surface of a housing. A duct-planned port with a large square shape is opened when a square-shaped air blowing duct is connected to the entire area of the side surface of the housing, and a duct-planned port with a round shape is opened when a round-shaped air blowing duct is connected to the side surface of the housing.

Disclosure of the Invention**Problem to be solved by the Invention**

[0003] The construction that the disc for adjusting the air blowing amount is disposed at the duct port has a problem that the number of parts is increased and the fabrication is more cumbersome. With respect to in-ceiling mount type air conditioners each of which is equipped with a face panel having an air suction port and an air blowing port, it has been recently required by users that an air blowing duct is connected, and air-conditioned air can be blown from both or one of the air blowing duct and the air suction port of the face panel. In this case, in order to make it easy to secure an air blowing duct afterwards, the in-ceiling mount type air conditioner is further required to be designed so that the air blowing amount can be easily adjusted when the air blowing duct is connected.

[0004] Therefore, an object is to provide an air condi-

tioner that can easily adjust the amount of air to be blown to an air blowing duct without increasing the number of parts even when the air blowing duct is secured afterwards.

Means of solving the Problem

[0005] An air conditioner according to claim 1 has a unit main body that is mounted in the ceiling of a room to be air-conditioned and contains a heat exchanger and an air blower in a substantially box-shaped housing, an air blowing duct being selectively connected to the housing, and knockout holes along edge portions of four opening-planned ports that can selectively intercommunicate with the air blowing duct are formed so as to be spaced from one another. According to the above construction, knockout holes along edge portions of plural opening-planned ports that can selectively intercommunicate with the air blowing duct are formed on the connection-planned face of the air blowing duct in the housing so as to be spaced from one another. Therefore, even when the air blowing duct is afterwards assembled, the air flow amount to the air blowing duct can be easily adjusted.

[0006] In this case, some of knockout holes along the edge portions of the opening-planned ports also may serve as some of the knockout holes along the edge portion of the other opening planned ports. Furthermore, a heat insulating member may be disposed in the housing, and the heat insulating member may prevent invasion of outdoor air through the knockout holes into the housing. Furthermore, a face grille that is secured to the ceiling surface and has an air blowing port and air suction port may be further provided.

Effect of the Invention

[0007] The knockout holes along the edge portion of the plural opening planned ports that can selectively intercommunicate with the air blowing duct are formed on the connection planned surface of the air blowing duct in the housing so as to be spaced from one another. Therefore, even when the air blowing duct is afterwards assembled, the air blow amount to the air blowing duct can be easily adjusted without increasing the number of parts.

Best Mode for carrying out the Invention

[0008] Embodiments of the present invention will be described hereunder in detail with reference to the drawings.

(1) First Embodiment

[0009] Fig. 1 is a perspective view showing the construction of an exterior appearance of an in-ceilingmount type air conditioner (hereinafter referred to as "air conditioner") according to a first embodiment. As shown in Fig. 1, the air conditioner 1 has a unit main body (the main

body of the air conditioner) 2, a face panel 3, and a suction grille 4. The unit main body 2 is mounted in the ceiling, and it has a box-shaped main body case 5 formed, of steel plate. Two suspending tags 6 are provided to each of both the side surfaces 5a of the main body case 5. The tags 6 are fixed to suspending bolts (not shown) suspended from the ceiling beams. When the unit main body 2 is mounted in the ceiling, the unit main body 2 is led from the ceiling hole provided on the ceiling face into the ceiling, the respective tags 6 are hooked and fixed to the suspending bolts, and the unit main body 2 is mounted in the ceiling.

[0010] Fig. 2 is a perspective view showing the exterior appearance of the face panel 3 under the state that the suction grille 4 is opened, and Fig. 3 is an exploded perspective view showing the face panel. The face panel 3 is formed of resin such as polystyrene (PS) or the like, provided to the ceiling face so as to close the ceiling hole and designed in a substantially rectangular shape as shown in Fig. 2. As shown in Fig. 3, the face panel 3 is fitted to the unit main body 2 by two temporarily hooking tags 30, and also fixed to the unit main body 2 by screws 80A, 80B (see Fig. 6). The face panel 3 is provided with one air suction port 7 for sucking indoor air and one air blowing port 8 for blowing air-conditioned air to a room. The margins of the air suction port 7, the air blowing port 8 and the face panel 3 are surrounded by heat insulating material 31. The suction grille 4 is provided to the air suction port 7 so as to be freely opened/closed.

[0011] A flap 14 is provided to the air blowing port 8 of the face panel 3 so as to be freely swingable. Specifically, the flap 14 is provided with two swing shafts 15, and each of the swing shafts 15 is supported by a bearing so as to be freely swingable. A foamed material 17 is provided to the air blowing port 8 to prevent dew condensation under cooling operation. Four maintenance openings 18 are provided to each of both the right and left sides of the face panel 3 so as to adjust the fixing height of the unit main body 2 by accessing the vicinity of the two suspending tags 6 of the unit main body 2, and side covers 19A, 19B covering these maintenance openings 18 are provided to the face panel 3 so as to be freely detachable. The details of the side covers 19A, 19B will be described in detail later. In addition, the face panel 3 is further provided with a light receiving portion fixing hole in which a light receiving portion 20 for optically receiving a signal from a wireless remote controller is fitted, etc.

[0012] Next, the internal construction of the unit main body 2 will be described with reference to Figs. 4 to 6. Fig. 4 is a perspective view showing the internal construction of the unit main body 2, and Fig. 5 is a cross-sectional view showing the construction of the unit main body 2 and the face panel 3. Fig. 6 is a plan view showing the air conditioner 1 from which a side cover 19 is detached when viewed from the floor side.

[0013] As shown in Fig. 4, the main body case 5 of the unit main body 2 is provided with a partition plate 40, and the main body case 5 is divided into a machine room 41

and a heat exchange room 42 by the partition plate 40. An air blower unit 50 and an electric component box 51 are disposed in the machine room 41. The air suction port 7 of the face panel 3 is provided so as to cover the machine room 41 (see Fig. 6), and indoor air is introduced from the air suction port 7 into the main body 2 of the air conditioner by an air blowing operation of the air blower unit 50. The air blower unit 50 is equipped with two centrifugal air blowers 52 disposed so as to be spaced from each other, and a motor 53 that is provided between the centrifugal air blowers 52 and drives the respective centrifugal air blowers 52 by the same shaft.

[0014] The centrifugal air blower 52 is provided with a multiblade fan on the inner peripheral surface of a cylinder member and rotationally driven with the center axis of the cylinder as a rotating axis by the motor 53, and a casing 55 that accommodates the multiblade fan 54 therein and is designed in a turbinated spiral shape in sectional view. Air suction ports 56 having the size corresponding to the diameter of the multiblade fan 54 are provided at both the sides of the casing 55, and the centrifugal air blowers 52 are disposed in the machine room 41 so that the air suction ports 56 face the sides of the unit main body 2. Furthermore, a ventilation flue 57 having a turbinated spiral shape in sectional view is formed in the casing 55 of the centrifugal air blower 52, and the discharge port (outlet) of the ventilation flue 57 is connected to an air introducing port (see Fig. 5) formed in the partition plate 40 through a duct 58. Accordingly, as indicated by arrows A in Fig. 4, indoor air is sucked from the air suction ports 56 at both the sides of the centrifugal blowers 52 by rotation of the multiblade fan 54 of the centrifugal air blowers 52, and discharged through the ducts 58 and the partition plate 40 to the heat exchange room 42 as indicated by arrows B. As shown in Fig. 5, a heat exchanger 60, a drain pan 62, etc. are disposed in the heat exchange room 42.

[0015] Here, the construction of the side panels 19A, 19B will be described. The side panel 19A and the side panel 19B have a symmetrical shape, and thus in the following description, the side panel 19A will be described. Fig. 7 is a perspective view showing the exterior appearance of the back side of the side panel 19A. The side panel 19A is roughly equipped with a main plate portion 90 having a substantially flat-plate shape, and a sub plate portion 91 located at the upper side of the main plate portion 90. The main plate portion 90 is provided with fitting portions 92A, 92B which are fitted to a fitting and receiving portion 81A of the face panel 3, a fitting portion 93 fitted to a fitting and receiving portion 81B of the face panel 3, a fitting portion 94 fitted to a fitting and receiving portion 81C of the face panel 3, a fitting portion 95 fitted to a fitting and receiving portion 81E of the face panel 3, and a fitting portion 96 fitted to a fitting and receiving portion 81F of the face panel 3.

[0016] The sub plate portion 91 is provided with a fitting portion 97 fitted to the fitting and receiving portion 81D (Fig. 6) of the face panel 3, a fitting portion 98 fitted to

the fitting and receiving portion 81G (Fig. 6) of the face panel 3, and a pocket portion 99 for covering the surrounding area of the screw 80B (Fig. 6) for fixing the face panel 3 to the main body 2 of the air conditioner under a substantially hermetical state. Furthermore, the peripheral edge portion of the pocket portion 99 at the face panel 3 side is formed as a flange portion 99A having a projecting shape.

[0017] The actual fixing of the side panel 19A to the face panel 3 is carried out by moving the side panel 19A in a direction of an arrow D1 (the direction to the face panel 3) shown in Figs. 6 and 7 to inset the side panel 19A at a predetermined position of the face panel 3, and further sliding the side panel 19A in a direction of an arrow D2 while the side panel 19A abuts against the face panel 3.

[0018] Fig. 8 is a sectional perspective view showing the state that the side panel 19A is secured to the face panel 3. As shown in Fig. 8, the flange portion 99A of the side panel 19A abuts against a flat-plate type frame portion 3A of the peripheral portion of the screw 80B in the face panel 3, and substantially hermetically covers the screw 80B in cooperation with the wall portion 99B (Fig. 7).

[0019] Furthermore, the fitting portions 92A, 92B are fitted to the fitting and receiving portion 81A of the face panel 3, the fitting portion 93 is fitted to the fitting and receiving portion 81B of the face panel 3, the fitting portion 94 is fitted to the fitting and receiving portion 81C of the face panel 3, the fitting portion 95 is fitted to the fitting and receiving portion 81E of the face panel 3, and the fitting portion 96 is fitted to the fitting and receiving portion 81F of the face panel 3.

[0020] In this embodiment, the screw 80B for fixing the face unit 3 to the unit main body 2 is substantially hermetically covered by the pocket portion 99 of the side panel 19A, 19B. Therefore, oil components floating in the air are prevented from adhering the portion of the face panel 3 to which stress is applied by the screw 80B, and thus the deterioration (crack or the like across the ages) of resin such as polystyrene (PS) constituting the face panel 3 can be suppressed.

(2) Second Embodiment

[0021] Fig. 9 is a perspective view showing the construction of the exterior appearance of an in-ceiling mount type air conditioner (hereinafter referred to as air conditioner) according to a second embodiment, and Fig. 10 is a cross-sectional view showing the air conditioner 100. The air conditioner 100 has a unit main body (the main body of the air conditioner) 110 for accommodating an air blower 102 and a heat exchanger 103, and a face panel 120 fixed to the lower portion of the unit main body 110 by screws. The unit main body 110 has a box-shaped housing 111 formed of a steel plate. The outer wall surface of the housing 111 is provided with plural suspending tags 112 connected to suspending bolts (not

shown) secured to the ceiling beams, and the unit main body 110 is mounted in the ceiling space of a room to be air-conditioned by the suspending tags 112.

[0022] The face panel 120 has a substantially rectangular exterior appearance larger than the housing 111 of the unit main body 110, and secured to the ceiling 104 so as to close a ceiling hole 105 when the unit main body 110 is inserted into the ceiling 104. Furthermore, an air suction port 121 for sucking air in the room to be air-conditioned is formed along one side edge portion in the longitudinal direction of the face panel 120, and an air blowing port 122 is formed along the other side edge portion.

[0023] A suction grille 124 supporting a filter 123 is freely detachably disposed at the air suction port 121 of the face panel 120, and a flap 125 extending in the width direction of the face panel 120 is disposed at the air blowing port 122 of the face panel 120. The flap 125 is supported to be swingable around a shaft 126 as a supporting point by driving a motor (not shown). As shown in Fig. 9, the face panel 120 has detachable side panels 127 which are disposed so as to face the suspending tags 112 of the housing 111, and when the side panel 127 is detached, the suspending tags 112 are exposed, and a worker can adjust the height of the unit main body 110 from the indoor.

[0024] As shown in Figs. 10 and 11, the unit main body 110 is provided with a partition plate for partitioning the internal space of the housing 11 into a machine room 130 and a heat exchange room 131. The air blower 102 and an electric component box 106 are disposed in the machine room 130, and a heat exchanger 103 and a refrigerant pipe 107 connected to the heat exchanger 103 are disposed in the heat exchange room 131. The refrigerant pipe 107 constitutes a refrigerant feed pipe for feeding refrigerant supplied from an outdoor unit (not shown) to the heat exchanger 103, and a part of a refrigerant return pipe for returning refrigerant circulated in the heat exchanger 103 to the outdoor unit.

[0025] The air blower 102 is equipped with two fan units 136 in which multiblade fans 135 are respectively mounted, and a motor 137 for rotationally driving the multifans 135 of the respective fan units 136. The motor 137 is driven on the basis of a driving signal from a control board mounted in the electric component box 106, and as shown in Fig. 10, air in the room to be air-conditioned is sucked through the air suction port 121 of the face panel 120 so that the indoor air cleaned by the filter is blown to the heat exchange room 131.

[0026] The heat exchanger 103 is applied to a fin-tube type heat exchanger, and it is disposed obliquely (tilt arrangement) in the heat exchange room 131. A drain pan of expanded polystyrene is disposed at the lower side of the heat exchanger 103 so that dew condensation water of the heat exchanger 103 does not leak to the room to be air-conditioned, and also the drain pan 138 serves as a part of a heat insulating member for thermally insulating the heat exchanger 103. The heat exchanger 131 is ther-

mally insulated by not only the drain pan 138, but also a heat insulating member 140 of expanded polystyrene disposed along the inner wall surface of the housing 111.

[0027] With the above construction, in the air conditioner 100, the indoor air in the room to be air-conditioned is sucked from the air suction port 121 of the face panel 120 through the filter 123 into the unit main body 110 by the air blower 102 as indicated by an arrow of Fig. 10, and then blown to the heat exchanger 103 to be heat-exchanged by the heat exchanger 103. Thereafter, the indoor air impinges against the inner wall surface 110A of the unit main body 110, and it is deflected to the substantially orthogonal direction and blown from the air blowing port 122 of the face panel 120. Accordingly, the indoor air is circulated in the heat exchanger 103 of the unit main body 110, whereby adjustment of the indoor temperature (indoor air conditioning) can be performed.

[0028] In the air conditioner 100 described above, an air blowing duct 150 (Fig. 13) is selectively connected to the side wall 111X of the housing 111 of the unit main body 110 in accordance with a user's demand or the like, and air-conditioned air which has been heat-exchanged in the heat exchanger 103 is allowed to be blown to the room to be air-conditioned through the air blowing duct 150. In this embodiment, as shown in Fig. 12, knockout holes 160 are formed along the edge portion of a duct-planed port D of the air blowing duct 150 in the outer wall surface (connection-planed surface) 111A of the side wall 111X to which the air blowing duct 150 will be connected so that the knockholes 160 are spaced from one another, and the members among the knockout holes 160 are cut out so that the knockout holes 160 intercommunicate with one another, whereby a duct port D0 (Fig. 14, Fig. 15) of the air blowing duct 150 can be easily formed.

[0029] More specifically, in this embodiment, as shown in Figs. 12, four duct-planed ports D1 to D4 which are symmetrically arranged on two vertical columns and two lateral lines are assumed as the duct-planed port D, and the knockout holes 160 each having a slender hole shape are formed along the edge portions of the respective duct-planed ports D1 to D4 so as to be spaced from one another. Here, with respect to the duct-planed ports D1 and D2 arranged in the vertical direction, the knockout holes 160 along the lower edge portion of the upper duct-planed port D1 serve as the knockout holes 160 along the upper edge portion of the lower duct-planed port D2. Accordingly, as compared with the case where the knockout holes 160 are formed so that the duct-planed ports D1 and D2 are spaced from each other, the number of knockout holes can be reduced, and the load of processing the knockout holes can be reduced.

[0030] With respect to the duct-planed ports D3 and D4 arranged in the vertical direction, as in the case of the duct-planed knockout holes D1 and D2, the knockout holes 160 along the edge portion of one duct-planed port D3 serve as the knockout holes 160 along the edge portion of the other duct-planed port D4, and the load of

processing the knockout holes 160 can be reduced. As described above, the heat insulating member 140 is disposed inside the knockout holes 160. Therefore, outside air is prevented from invading through the knockout holes 160 into the unit main body 110 by the heat insulating member 140, and thus the heat insulation in the unit main body 110 is kept.

[0031] Fig. 13 is a perspective view showing an example of the air blowing duct 150. The air blowing duct 150 comprises a metal housing 151 connected to the unit main body 110 of the air conditioner 100, a metal housing 152 intercommunicating with an opening (blowing duct air sending port) provided to the ceiling or the like, and a connecting member 152 that connects the housings 151 and 152 and is formed of flexible material. The orientation of one housing 153 can be changed in any direction with respect to the other housing 152 by the connecting member 153. A flange 154 extending inwardly is provided to an opening portion 151A of the housing 151. Plural pinholes 155 are provided to the flange 154, and hook members 156 are connected to the flange portion 154 by pins so as to be spaced from one another. The hook member 156 is formed by bending a metal plate member in a substantially U-shape, and it is designed so that the U-shaped portion thereof is hooked to the unit main body 110. The hook member 156 can temporarily support the opening portion 151A side of the air blowing duct 150 to the fixing position of the unit main body 110 by hooking the U-shaped portions to the unit main body 110.

[0032] Figs. 14 and 15 is a partially cross-sectional view showing the state that the air blowing duct 150 is connected to the unit main body 110 of the air conditioner 100. As shown in Figs. 14 and 15, when the air blowing duct 150 is connected to the unit main body 110, any one or more of the duct-planed ports D1 to D4 of the unit main body 110 are opened as the duct port D0, and also a part of the heat insulating member 14 which shields the duct port D0 is cut out so that the duct port D0 and the heat exchange room 131 intercommunicate with each other. Thereafter, female screw holes are formed at the positions corresponding to the pin holes 55 of the air blowing duct 150 on the connection-planed surface 111A of the unit main body 110, and the air blowing duct 150 is pin-fastened to the female screw holes through the pin holes 155, whereby the air blowing duct 150 is connected to the unit main body 110. In this case, in order to make the air flow amount blown from the air blowing duct 150 equal between the right and left sides, it is preferable that when the duct-planed port D1 is set to the duct port D0, the duct-planed port D3 is also set to the duct port D0. Likewise, it is preferable that when the duct-planed port D2 is set to the duct port D0, the duct-planed port D4 is set to the duct port D0.

[0033] When the air blowing duct 150 is connected to the unit main body 110 as described above, the hook members 156 of the air blowing duct 150 are drawn out and hooked to the lower edge portion D0L of the duct

port D0 of the unit main body 110 through a heat insulating cushion member 157 to keep the duct port side of the air blowing duct 150 under a floated state, and the air blowing duct 150 is positioned under the floated state and connected by pins. Therefore, if the duct port side of the air blowing duct 150 can be once lifted up, the duct port side can be temporarily fitted by the hook members 156 while floated, and the connecting work of the air blowing duct 150 can be facilitated. The heat insulating cushion member 157 is formed of a heat insulating member having cushion property to be embedded in the gap between the air blowing duct 150 and the unit main body 110, and it is formed of polyethylene, for example. By inserting the heat insulating cushion member 157 between the air blowing duct 150 and the unit main body 110, the gap between the air blowing duct 150 and the unit main body 110 can be perfectly shielded and also sufficient heat insulation can be performed.

[0034] As shown in Fig. 14, when only the duct-planed ports D2 and D4 of the unit main body 110 are set to the duct port D0, the air flow amount to be supplied to the air blowing duct 150 can be set to a small value, and thus the distribution rate of the air-conditioned air supplied to the air blowing duct 150 and the air blowing port 122 of the face panel 120 can be set to be larger at the air blowing port 122 side.

[0035] On the other hand, when all the duct-planed ports D1 to D4 of the unit main body 110 are set to the duct port D0, the opening area of the duct port D0 is set to be larger than the case of Fig. 14, and thus the air flow amount to be supplied to the air blowing duct 150 can be increased. Therefore, the distribution rate of the air-conditioned air supplied to the air blowing duct 150 and the air blowing port 122 of the face panel 120 can be set to be larger at the air blowing duct 150 side.

[0036] In this embodiment, the knockout holes 160 located along the edge portions of the plural duct-planed ports D1 to D4 are formed in the housing 111 so as to be spaced from one another, and the duct-planed ports D1 to D4 are selectively opened and set to the duct port D0. Therefore, the air flow amount supplied to the air blowing duct 150 can be adjusted, and the distribution rate of the air-conditioned air supplied to the air blowing duct 150 and the air blowing port 122 of the face panel 120 can be freely adjusted.

[0037] Furthermore, when the duct port D0 is formed, it is sufficient only to selectively cut out the knockout holes 160 formed in the housing 111. Therefore, as compared with the prior art having a disc for adjusting the air flow amount to the air blowing duct, the air flow to the air blowing duct can be more easily adjusted without increasing the number of parts, and the air blowing duct can be afterwards assembled. The air conditioner 100 may be designed so that when the air blowing duct 150 is connected, the air conditioner, the air blowing port 122 of the face panel 120 is closed by a closing member and the air-conditioned air is blown from only the air blowing duct 150.

[0038] The embodiments of the present invention have been described above. However, the present invention is not limited to these embodiments, and various modifications may be made. For example, in the first embodiment, the pocket portion 99 is constructed as the hermetically accommodating portion for accommodating the portion exposed to the side panel 19A side of the screw 80B as a fixing member while the portion concerned is substantially hermetically sealed. However, it may be modified so that the head portion of the screw is located in a recess portion, the recess portion concerned is sealed by a lid member so that the lid member is detachable from the recess portion, and the hermetically accommodating portion is constructed by the recess portion and the lid member. Likewise, the shape of the pocket portion 99 is not limited to the box-shape like this embodiment, but various shapes such as a cylindrical shape, etc. may be applied.

[0039] In the second embodiment, which does not form part of the claimed invention, the knockout holes 160 which can easily open the four duct-planed ports D1 to D4 arranged in the two vertical columns and two lateral lines are formed in the unit main body 110 in advance. However, the number and shape of the duct-planed ports may be arbitrary. For example, knockout holes corresponding to duct-planed ports D1 to D4 arranged four lateral lines which are symmetrical with respect to the right and left sides may be formed as shown in Fig. 16. In this case, when the air blowing amount of the air blowing duct 150 is reduced, the duct-planed ports D2 and D3 may be set to the duct port D0, and when the air blowing amount is increased, all the duct-planed ports D1 to D4 may be opened and set to the duct port D0. Furthermore, the shape of the knockout holes is not limited to the slender hole shape, and various hole shapes such as a round hole, etc. may be applied.

Brief Description of the Drawings

[0040]

[Fig. 1] is a perspective view showing the exterior appearance construction of an air conditioner according to a first embodiment.

[Fig. 2] is a perspective view showing the exterior appearance construction of a face panel under the state that a suction grille is opened.

[Fig. 3] is an exploded perspective view showing the face panel.

[Fig. 4] is a perspective view showing the internal construction of the main body of the air conditioner.

[Fig. 5] is a cross-sectional view showing the construction of the main body of the air conditioner and the face panel.

[Fig. 6] is a plan view showing the air conditioner from which a side cover is detached when viewed from the floor side.

[Fig. 7] is a perspective view showing the exterior

appearance construction of the back side of the side panel.

[Fig. 8] is a cross-sectional perspective view showing the state that the side panel is secured to the face panel.

[Fig. 9] is a perspective view showing the exterior appearance construction of the air conditioner according to a second embodiment.

[Fig. 10] is a cross-sectional view showing the air conditioner.

[Fig. 11] is a perspective view showing a unit main body of the air conditioner.

[Fig. 12] is a perspective view showing the exterior appearance of the unit main body.

[Fig. 13] is a perspective view showing an example of an air blowing duct.

[Fig. 14] is a partial cross-sectional view showing the state that the air blowing duct is connected to the unit main body.

[Fig. 15] is a partial cross-sectional view showing the state that the air blowing duct is connected to the unit main body.

[Fig. 16] is a perspective view showing the exterior appearance of the unit main body provided to explain a modification.

which does not form part of the claimed invention.

Description of Reference Numerals

[0041]

- 1, 100 air conditioner
- 2, 110 unit main body (main body of air conditioner)
- 3, 120 face panel
- 4 ... frame (hermetically accommodating portion)
- 7, 121 suction grille
- 8, 122 air blowing port
- 14, 125 flap
- 19A ... side panel
- 19B ... side panel
- 80A ... screw (fixing member)
- 80B ... screw (fixing member)
- 90 ... main plate portion
- 91 ... sub plate portion
- 99 ... pocket portion (hermetically accommodating portion)
- 99A ... flange portion
- 150 air blowing duct
- 160 knockout hole
- D1 to D4 duct-planned port (opening planned port)

Claims

1. An air conditioner having a unit main body (110) that is mounted in the ceiling of a room to be air-conditioned and contains a heat exchanger (103) and an

air blower (102) in a substantially box-shaped housing (111) and a face panel (120) that is secured to the ceiling surface and has an air blowing port (122) and an air suction port (121), **characterized in that** an air blowing duct (150) is selectively connected to one side surface of the housing, knockout holes (160) along edge portions of four duct-planned ports (D1 to D4) that can selectively intercommunicate with the air blowing duct and are arranged inside an opening portion (151A) of the air blowing duct are formed on the side surface to which the air blowing duct is to be connected so that the knockout holes are spaced from one another, the four duct-planned ports are symmetrically arranged on two vertical columns and two lateral lines, the four duct-planned ports comprise: lower duct-planned ports (D2, D4) that are opened when the air blowing duct is connected to the housing whereby a distribution rate of air-conditioned air supply to the air blowing duct and the air blowing port of the face panel is set to be larger at an air blowing port side; and upper duct-planned ports (D1, D3) that are open together with the upper duct-planned ports when the distribution rate of the air-conditioned air is set to be larger at an air blowing duct side, the opening portion of the housing is provided with a flange (154) extending inwardly and being connected to the housing by pins, and the flange portion is provided with hook members (156) that are drawn out and hooked to a lower edge portion (DOL) of the opened lower duct-planned ports to keep the duct port side of the air blowing duct under a floated state, and the air blowing duct is positioned.

2. The air conditioner according to claim 1, wherein some of knockout holes along the edge portions of the opening-planned ports also serve as some of the knockout holes along the edge portion of the other opening-planned ports.
3. The air conditioner according to claim 1, wherein a heat insulating member is disposed in the housing, and the heat insulating member prevents invasion of outdoor air through the knockout holes into the housing.

Patentansprüche

1. Klimaanlage, die einen Anlagenhauptkörper (110) aufweist, der in der Decke eines zu klimatisierenden Raumes montiert ist und einen Wärmetauscher (103) und ein Luftgebläse (102) in einem im wesentlichen kastenförmigen Gehäuse (111) und eine Frontplatte (120), die an der Deckenoberfläche befestigt ist und eine Luftausblasöffnung (122) und eine Luftansaugöffnung (121) aufweist, **dadurch gekennzeichnet, dass**

ein Luftausblaskanal (150) selektiv mit einer Seitenoberfläche des Gehäuses verbunden ist, Ausbrechlöcher (160) entlang Randteilen von vier für Kanäle geplanten Öffnungen (D1 bis D4), die wahlweise mit dem Luftauslasskanal in gegenseitiger Verbindung stehen können und im Inneren eines Öffnungsteils (151A) des Luftausblaskanals auf der Seitenoberfläche gebildet sind, mit denen der Luftausblaskanal zu verbinden ist, sodass die Ausbrechlöcher voneinander beabstandet sind, die vier für Kanäle geplanten Öffnungen symmetrisch auf zwei vertikalen Spalten und zwei Querlinien angeordnet sind, die vier für Kanäle geplanten Öffnungen umfassen: untere für Kanäle geplante Öffnungen (D2, D4), die geöffnet werden, wenn der Luftauslasskanal mit dem Gehäuse verbunden wird, wodurch eine Verteilungsrate von klimatisierter Luftzufuhr zu dem Luftauslasskanal und der Luftausblasöffnung der Frontplatte so eingestellt wird, dass er an einer Luftausblasöffnungsseite größer sein soll; und obere für Kanäle geplante Öffnungen (D1, D3), die gemeinsam mit den oberen für Kanäle geplanten Öffnungen geöffnet werden, wenn die Verteilungsrate der klimatisierten Luft so eingestellt wird, dass sie an einer Luftauslasskanalseite größer sein soll, der Öffnungsteil des Gehäuses mit einem Flansch (154) versehen ist, der sich nach innen erstreckt und mit dem Gehäuse durch Stifte verbunden ist, und der Flanschteil mit Hakenelementen (156) versehen ist, die nach außen gezogen sind und an einen unteren Randteil (DOL) der geöffneten unteren für Kanäle geplanten Öffnungen gehakt werden, um die Kanalöffnungsseite des Luftausblaskanals in einem schwebenden Zustand zu halten, und der Luftauslasskanal positioniert wird.

2. Klimaanlage gemäß Anspruch 1, wobei einige der Ausbrechlöcher entlang der Randteile der für Öffnungen geplanten Öffnungen ebenfalls als einige der Ausbrechlöcher entlang des Randteils der anderen für Öffnungen geplanten Öffnungen dienen.
3. Klimaanlage gemäß Anspruch 1, wobei ein wärmeisolierendes Element in dem Gehäuse angeordnet ist und das wärmeisolierende Element das Eindringen von Außenluft durch die Ausbrechlöcher in das Gehäuse verhindert.

Revendications

1. Climatiseur ayant un corps principal d'unité (110) qui est monté dans le plafond d'une pièce à climatiser et contient un échangeur de chaleur (103) et une souffleuse d'air (102) dans un boîtier sensiblement en forme de boîte (111) et un panneau de face (120) qui est fixé à la surface du plafond et comporte un

orifice de soufflage d'air (122) et un orifice d'aspiration d'air (121), **caractérisé en ce que** un conduit de soufflage d'air (150) qui est raccordé de façon sélective à une surface latérale du boîtier, des trous à défoncer (160) le long de parties de bord de quatre orifices prévus pour le conduit (D1 à D4) qui peuvent de façon sélective intercommuniquer avec le conduit de soufflage d'air et sont disposés à l'intérieur d'une partie d'ouverture (151A) du conduit de soufflage d'air, sont formés sur la surface latérale à laquelle le conduit de soufflage d'air doit être raccordé de telle sorte que les trous à défoncer soient espacés les uns des autres, les quatre orifices prévus pour le conduit sont disposés de façon symétrique sur deux colonnes verticales et deux lignes latérales, les quatre orifices prévus pour le conduit comprennent : des orifices inférieurs prévus pour le conduit (D2, D4) qui sont ouverts lorsque le conduit de soufflage d'air est raccordé au boîtier, grâce à quoi une vitesse de distribution de l'alimentation en air climatisé au conduit de soufflage d'air et à l'orifice de soufflage d'air du panneau de face est établie de sorte à être plus importante côté orifice de soufflage d'air ; et des orifices supérieurs prévus pour le conduit (D1, D3) qui sont ouverts conjointement avec les orifices supérieurs prévus pour le conduit lorsque la vitesse de distribution de l'air climatisé est établie de sorte à être plus importante côté conduit de soufflage d'air, la partie d'ouverture du boîtier est pourvue d'un rebord (154) s'étendant vers l'intérieur et qui est raccordé au boîtier par des broches et la partie de rebord est pourvue d'éléments de crochet (156) qui sont sortis et accrochés à une partie de bord inférieure (DOL) des orifices inférieurs ouverts prévus pour le conduit pour garder le côté orifice de conduit du conduit de soufflage d'air dans un état flottant, et le conduit de soufflage d'air est positionné.

2. Climatiseur selon la revendication 1, dans lequel quelques-uns des trous à défoncer le long des parties de bord des orifices prévus pour l'ouverture servent également à quelques-uns des trous à défoncer le long des parties de bord des autres orifices prévus pour l'ouverture.
3. Climatiseur selon la revendication 1, dans lequel un élément thermo-isolant est disposé dans le boîtier et l'élément thermo-isolant empêche une entrée d'air extérieur par les trous à défoncer dans le boîtier.

FIG. 2

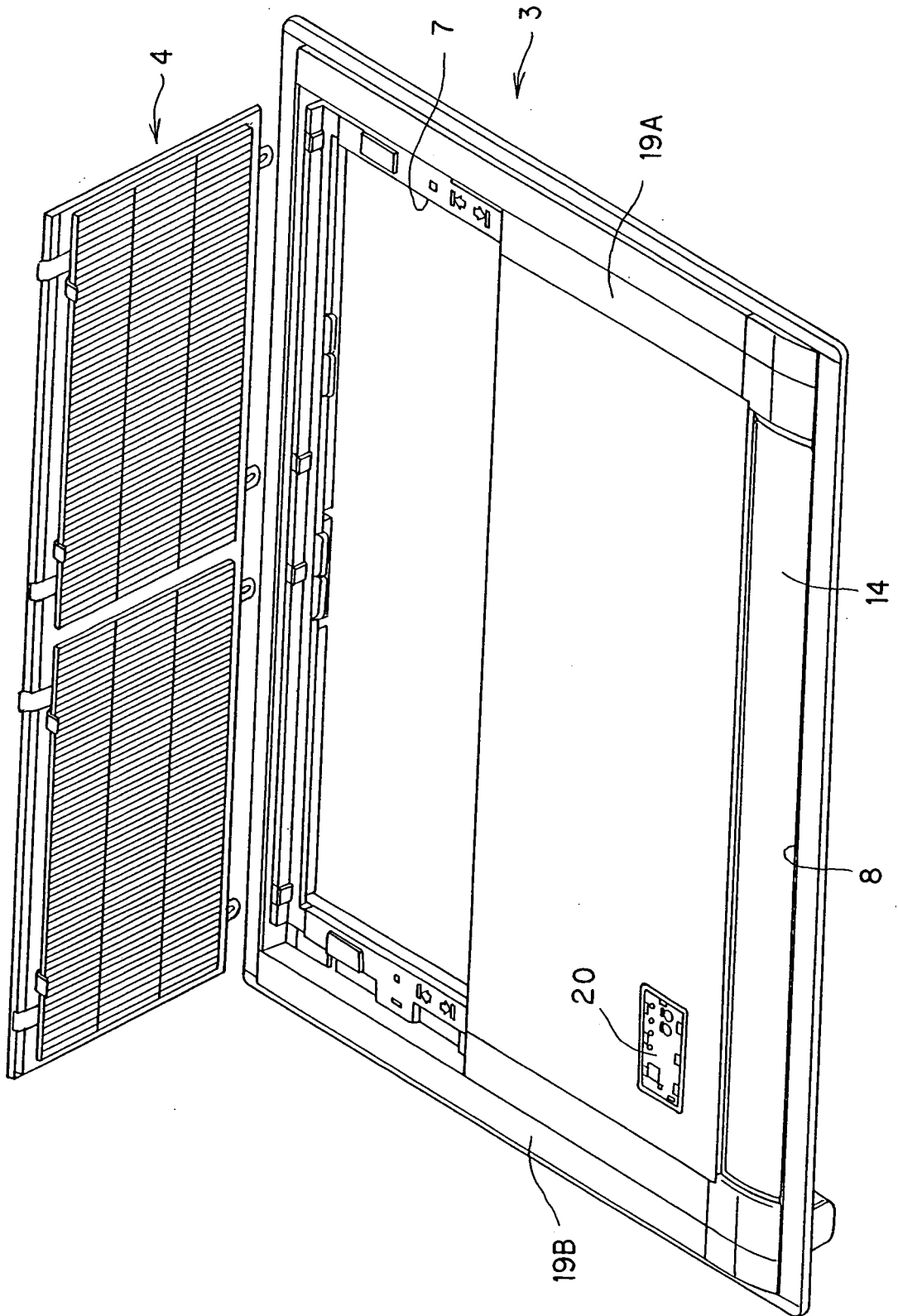

FIG. 3

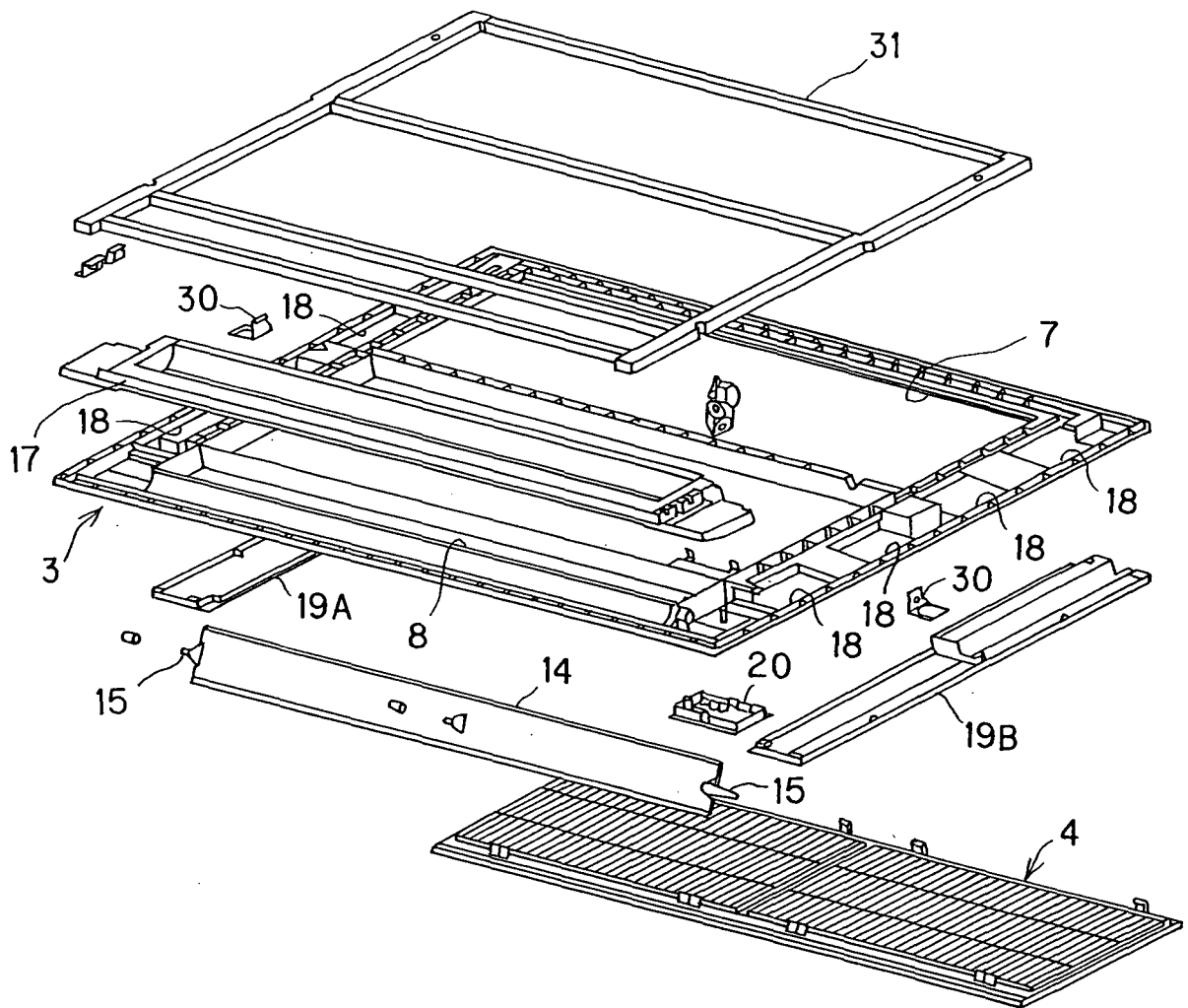

FIG. 4

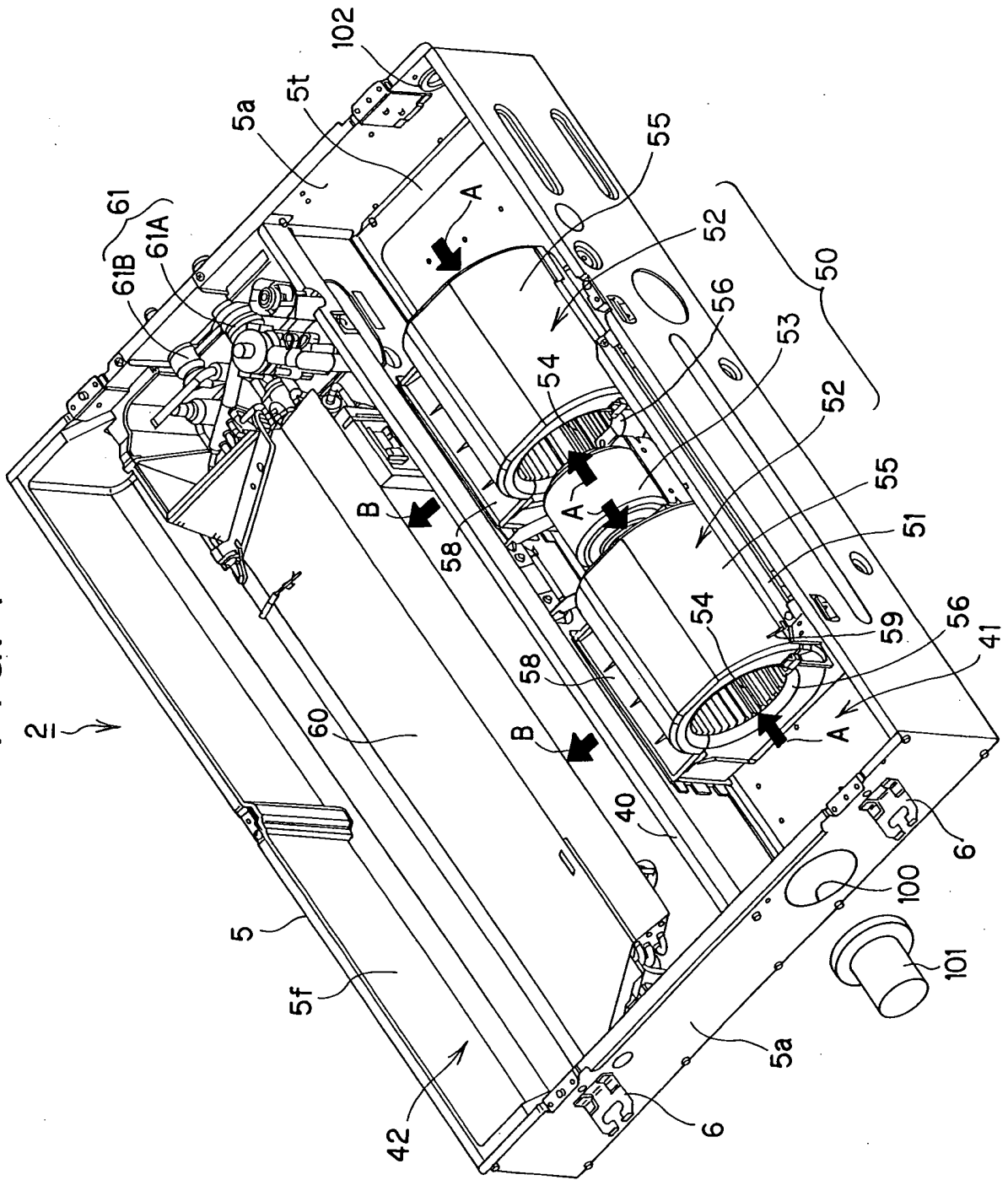

FIG. 5

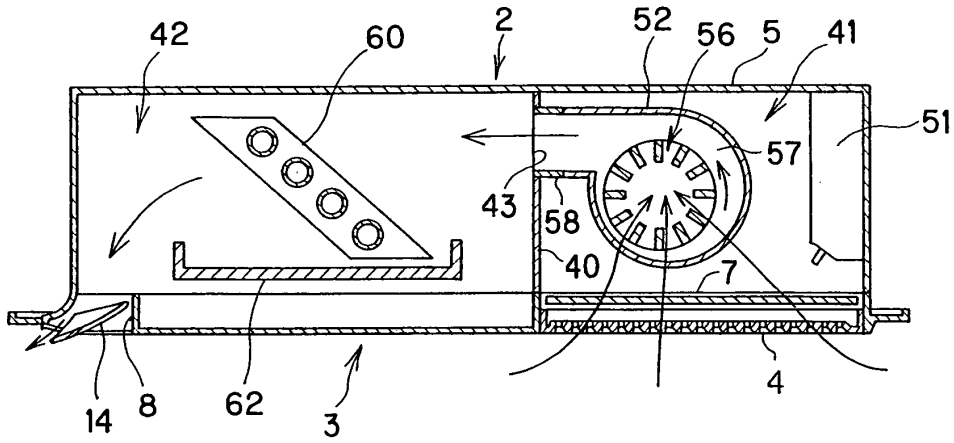

FIG. 6

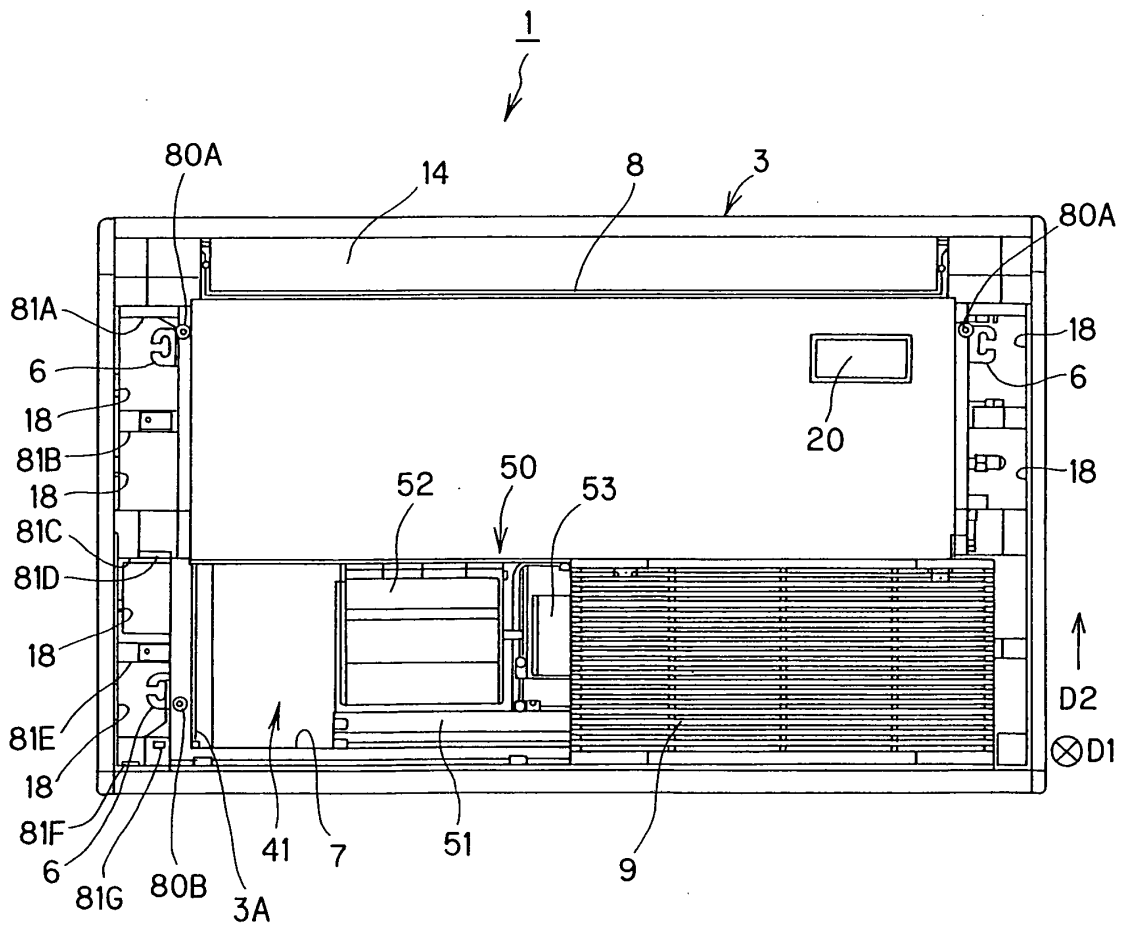

FIG. 7

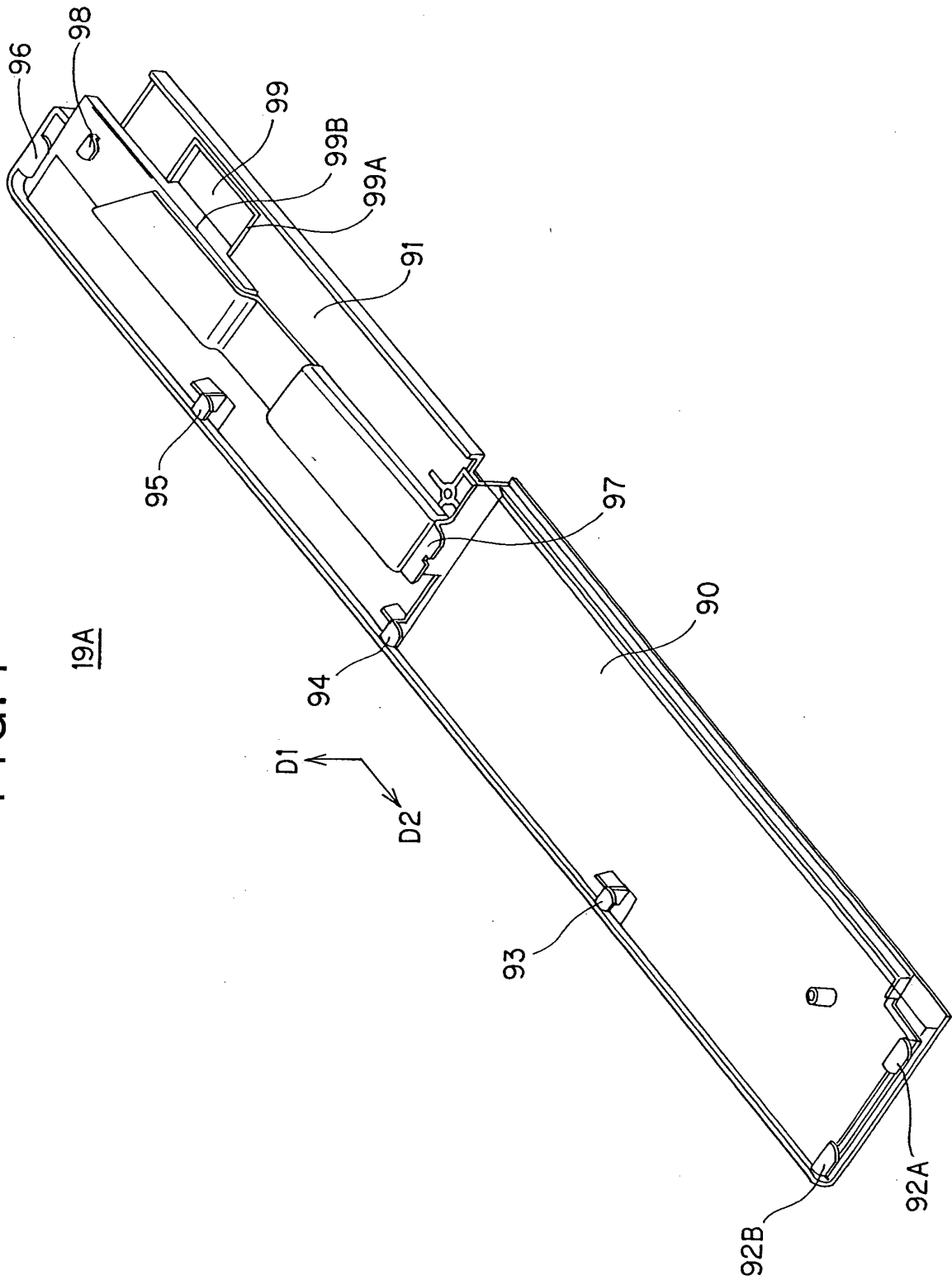

FIG. 8

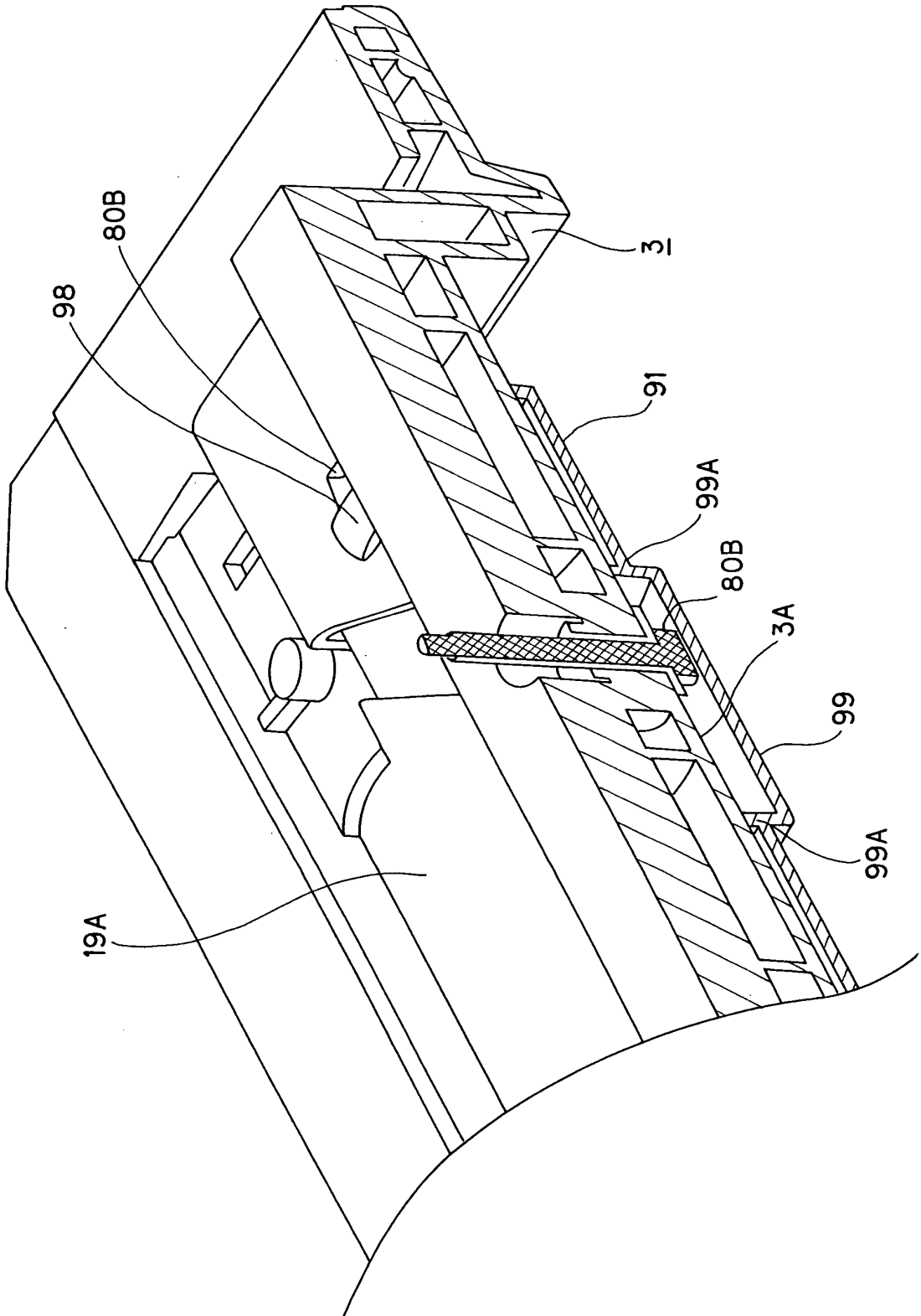

FIG. 9

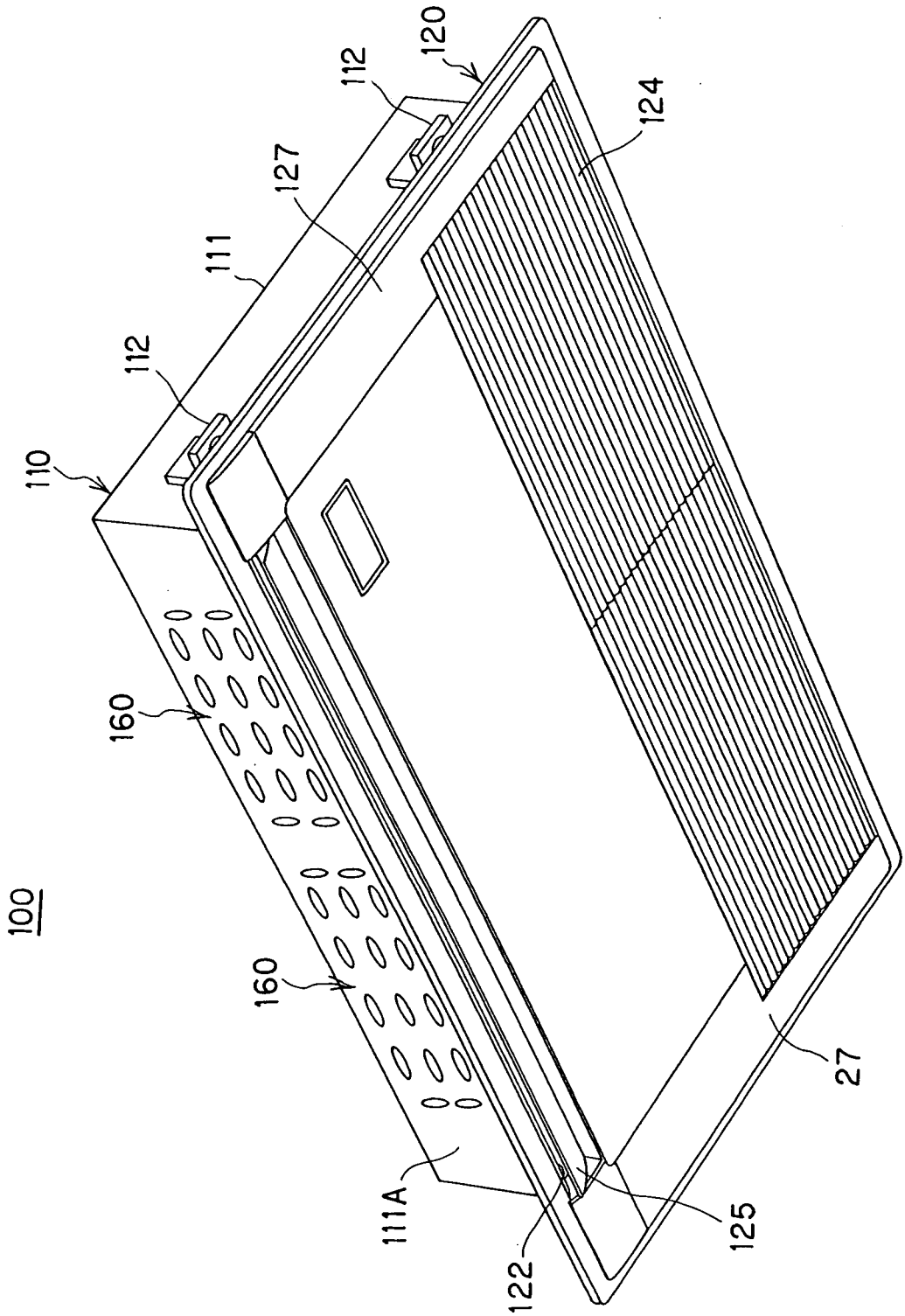

FIG. 10

100

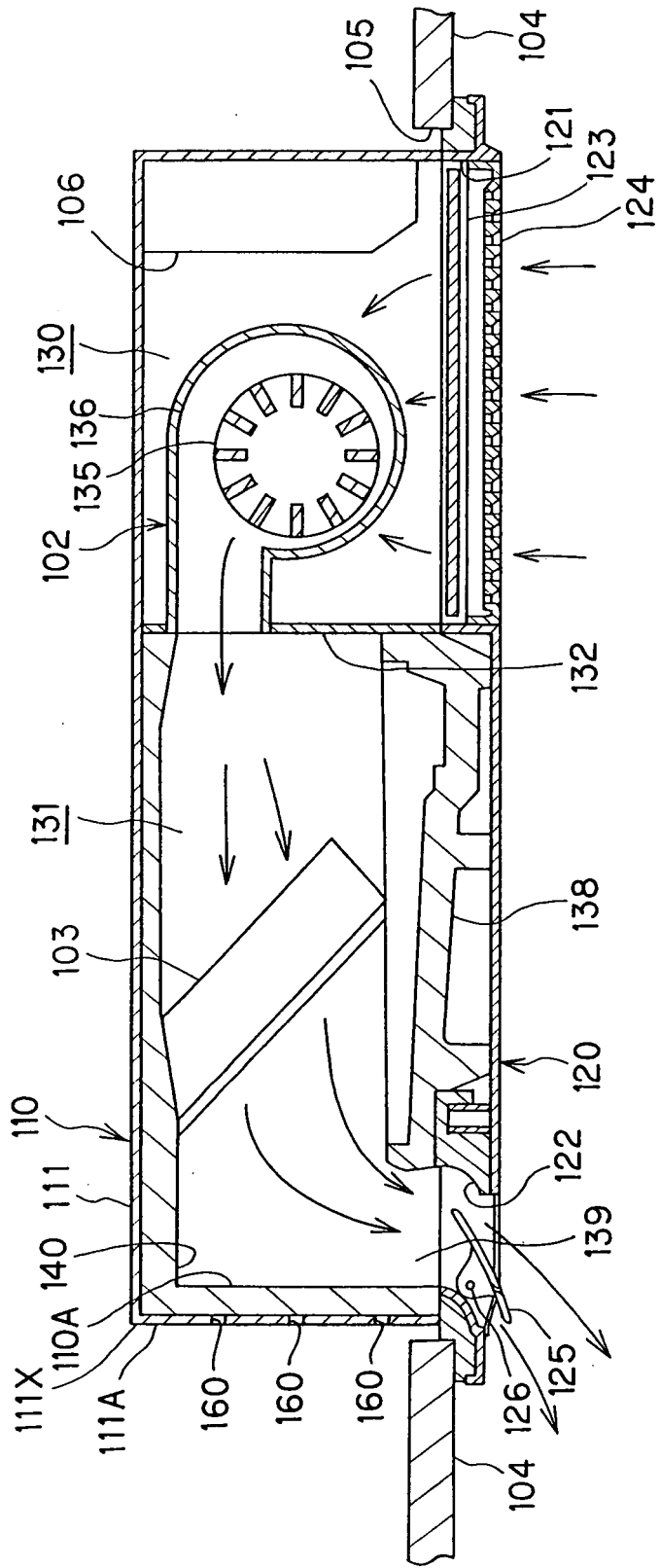

FIG. 11

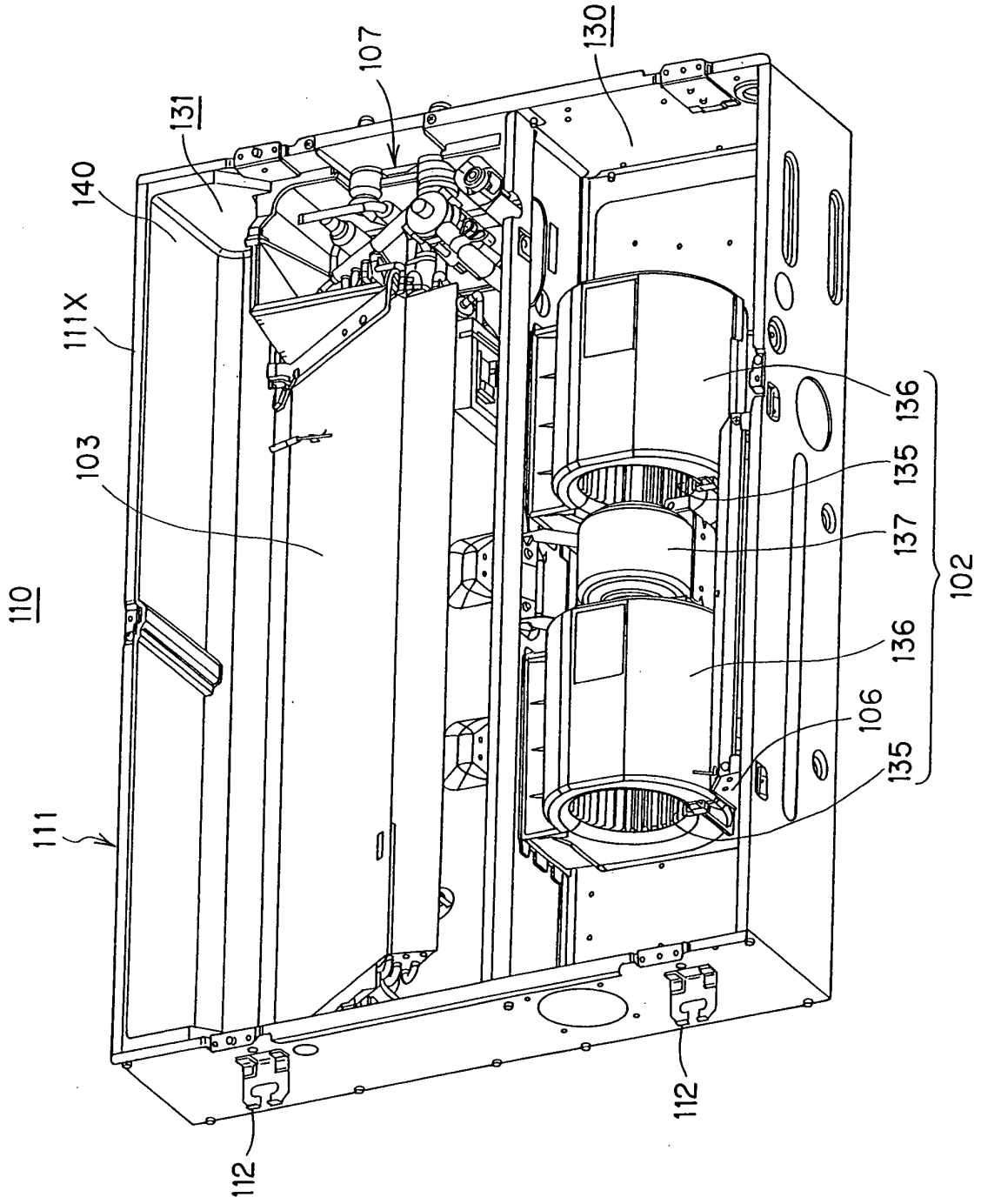

FIG.13

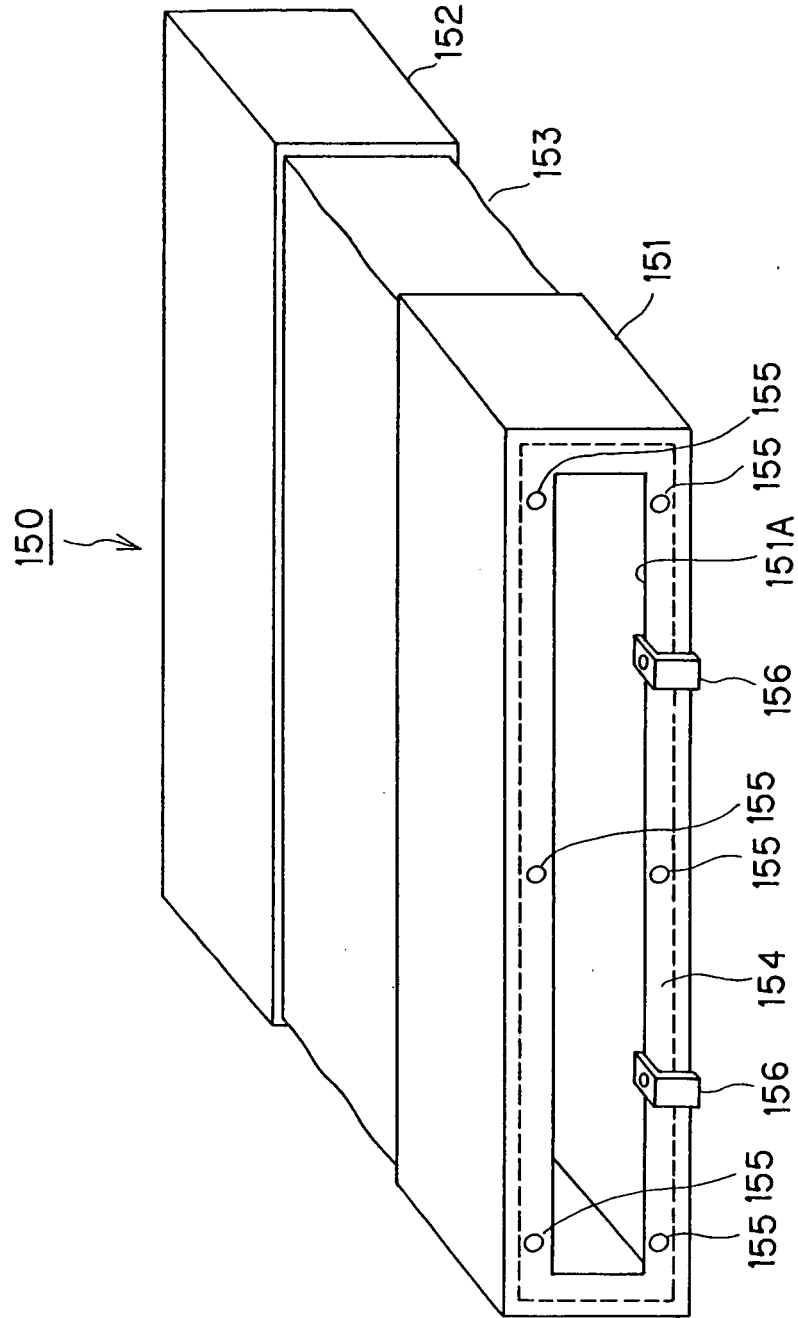

FIG. 14

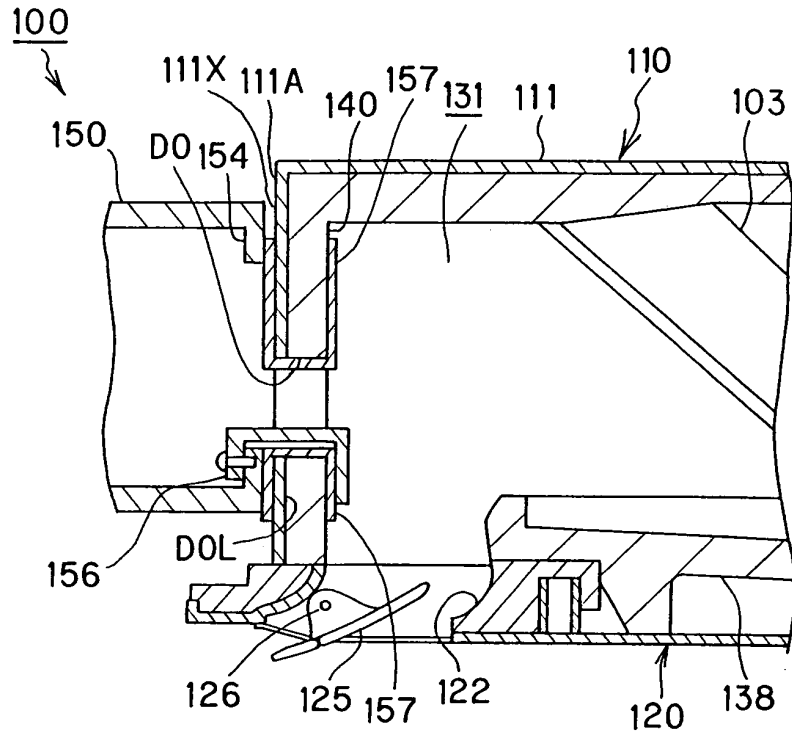

FIG. 15

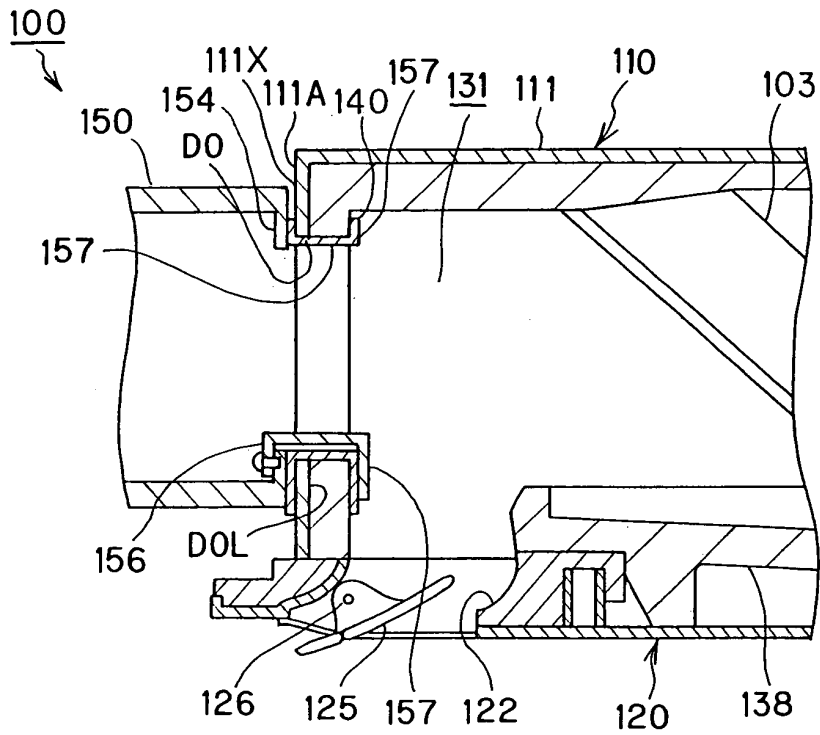
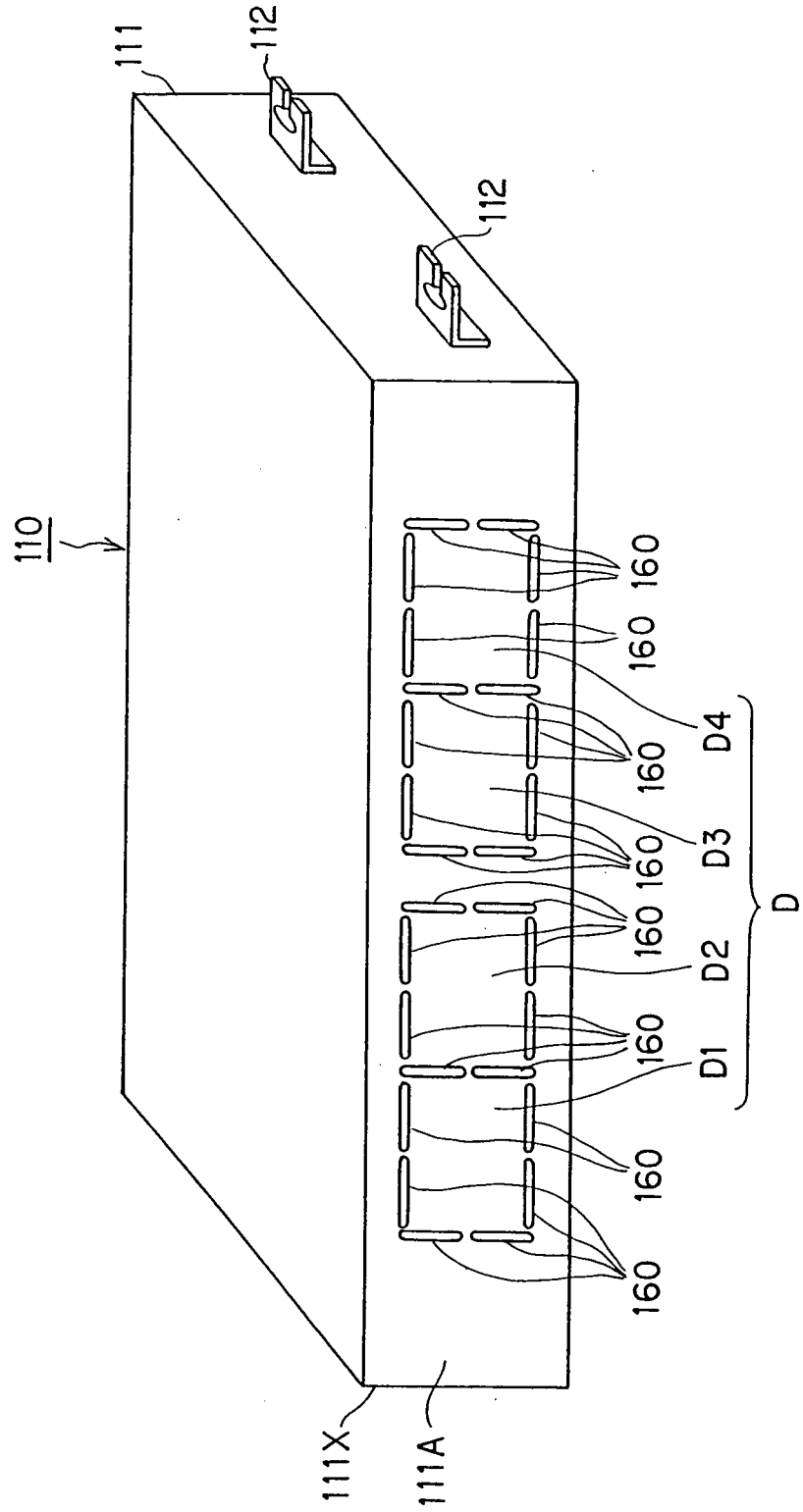

FIG. 16



REFERENCES CITED IN THE DESCRIPTION

This list of references cited by the applicant is for the reader's convenience only. It does not form part of the European patent document. Even though great care has been taken in compiling the references, errors or omissions cannot be excluded and the EPO disclaims all liability in this regard.

Patent documents cited in the description

- JP 2003194394 A [0002]
- JP 7022344 A [0002]
- JP 7022344 U [0002]