



(11) **EP 2 169 138 B1**

(12) **EUROPEAN PATENT SPECIFICATION**

(45) Date of publication and mention of the grant of the patent:  
**27.11.2013 Bulletin 2013/48**

(51) Int Cl.:  
**E04D 13/03<sup>(2006.01)</sup> E04D 13/035<sup>(2006.01)</sup>**

(21) Application number: **09171282.8**

(22) Date of filing: **24.09.2009**

(54) **Skylight with covering device**

Dachfensterabdeckung

Lucarne avec un couvercle de protection

(84) Designated Contracting States:  
**AT BE BG CH CY CZ DE DK EE ES FI FR GB GR HR HU IE IS IT LI LT LU LV MC MK MT NL NO PL PT RO SE SI SK SM TR**  
Designated Extension States:  
**AL BA RS**

(30) Priority: **25.09.2008 IT VI20080223**

(43) Date of publication of application:  
**31.03.2010 Bulletin 2010/13**

(73) Proprietors:  
• **Caoduro, Paolo**  
**36100 Vicenza (IT)**  
• **Caoduro, Carlo**  
**36010 Monticello Conte Otto, VI (IT)**

(72) Inventors:  
• **Caoduro, Paolo**  
**36100 Vicenza (IT)**  
• **Caoduro, Carlo**  
**36010 Monticello Conte Otto, VI (IT)**

(74) Representative: **Bonini, Ercole**  
**Studio Bonini Srl**  
**Corso Fogazzaro, 8**  
**36100 Vicenza (IT)**

(56) References cited:  
**WO-A-01/59232 DE-A1- 2 146 932**  
**DE-A1- 10 138 731 DE-B- 1 290 325**  
**FR-A- 2 661 703**

**EP 2 169 138 B1**

Note: Within nine months of the publication of the mention of the grant of the European patent in the European Patent Bulletin, any person may give notice to the European Patent Office of opposition to that patent, in accordance with the Implementing Regulations. Notice of opposition shall not be deemed to have been filed until the opposition fee has been paid. (Art. 99(1) European Patent Convention).

## Description

**[0001]** The present invention relates to an improved covering device particularly suited to be applied to openings made in buildings.

**[0002]** The use of covering elements that are provided with fixed or opening covers applied to the openings made in buildings for the intake of light and/or air is known.

**[0003]** Usually each opening is associated with a covering element provided with one cover only, however, in the case of large openings the covering element may comprise several independent covers arranged side by side, which can be opened selectively by the user according to his/her needs.

**[0004]** In particular, if the openings are made in the roof of the building, the covering elements are skylights for the intake of light and air, or smoke and heat vents that open automatically in case of emergency.

**[0005]** If, on the other hand, the openings are made in the walls of the building, the covering elements are windows provided with manual or automatic opening and closing devices.

**[0006]** The covers of the covering devices described above are usually made of transparent or semi-transparent materials in two and sometimes even three layers, because in addition to ensuring the passage of light they must also have low heat transmittance, in order to reduce as much as possible heat exchanges with the outside.

**[0007]** Document WO 01/59232 A1 discloses window frame structures, e.g. for double layer acrylic dome-shaped windows, with improved insulating profiles situated between the window (cover) and the opening in the building.

**[0008]** The German Patent application DE 101 38 731 A7 describes a coupled window wherein one frame-less glass panel is attached to the frame of an insulating window. An annular sealing interposed between frame and glass panel is also mentioned. The glass panel is movable with respect to the insulating window when the latter one is in an open position.

**[0009]** All the covering devices described, however, pose some drawbacks and/or limitations.

**[0010]** First of all, the transparency of the materials used for making the covers offers the advantage of permitting the passage of light and therefore of lighting the rooms in a natural and diffused manner but also poses the drawback of not being able to prevent direct sun radiation, especially in some periods of the year or in specific moments of the day, with particularly annoying effects for the persons and damaging effects for the things present therein.

**[0011]** The installation of suitable shields or curtains under the covers of the covering elements makes it possible to intercept the sun rays and therefore to eliminate the annoying direct radiation but also poses the drawback of transferring into the room all the heat absorbed by said shields or curtains. Consequently, the ambient temper-

ature increases, and with it also the related air conditioning costs deriving from the need to maintain temperature at standard values.

**[0012]** Another drawback posed by the covering devices of known type is represented by the fact that, especially in clear winter nights, the sky vault behaves like a blackbody that absorbs the heat of the environment through the transparency of the covers of the covering elements and thus cools it. It is thus necessary to keep the heating system in operation in order to prevent the temperature from lowering too much and avoid the formation of condensate on the covering elements.

**[0013]** A further drawback is represented by the fact that in some particularly critical situations the coefficient of transmittance of the covering elements cannot guarantee, both in summer and in winter, the desired heat insulation from the external environment.

**[0014]** Another drawback lies in that particularly heavy atmospheric precipitation, like for example hail, can seriously damage the covers of the covering elements.

**[0015]** Finally, a limitation posed by the known covering elements is represented by the fact that they do not allow the user to regulate the flow of light that enters the room through the opening to which they are applied.

**[0016]** A device for covering openings made in the roof of buildings, comprising a protective shield placed over a cover applied to each opening, is known from the German patent DE 1 290 325, in which the protective shield is sustained by supporting columns arranged on its perimeter in order to keep it spaced from the underlying cover.

**[0017]** This solution poses a first limitation lying in that the supporting columns fix the shield to the underlying cover and therefore after installation the shield remains stable in the position in which it has been installed.

**[0018]** Not being possible to modify its position in relation to the cover, it is not possible to vary the light flow entering the room in order to adapt it to the user's needs.

**[0019]** Therefore, the regulation of the light flow let in may only derive from the degree of light absorption of the material with which the shield is made.

**[0020]** Another limitation is represented by the fact that the supporting columns are spaced from one another and therefore do not create a barrier against the passage of light through the perimetral area included between the shield and the underlying cover. Therefore, it is not possible to darken the room completely.

**[0021]** A further limitation lies in that the supporting columns do not perform any heat insulating function as they do not prevent heat exchange with the outside along the perimetral area between shield and cover.

**[0022]** Another limitation lies in the fact that, being it impossible to move the protective shield and therefore to orient it in relation to the direction from which the sun rays originate, the covering device cannot prevent direct sun radiation into the rooms under the openings.

**[0023]** The present invention intends to overcome the limitations and drawbacks described above.

**[0024]** In particular, it is a first object of the invention to provide an improved covering device that makes it possible to regulate the flow of light let in the room through the opening to which it is applied.

**[0025]** It is a further object of the invention to provide a covering device that allows the light flow let into the room to be regulated until completely darkening the room.

**[0026]** It is another object of the invention to provide a covering device that can prevent direct sun radiation in the rooms under the openings to which it is applied.

**[0027]** It is another object of the invention to provide a covering device that, when in closed position, has transmittance values lower than those of the covering devices of known type.

**[0028]** It is another yet not the least object of the invention to provide a covering device that is more resistant and therefore less subject to suffer damage in case of heavy precipitation, for example hail, compared to the covering devices of known type.

**[0029]** The objects described above are achieved by a covering device having the characteristics described in the main claim, to which the reader should refer for the sake of brevity.

**[0030]** Other details of the invention are described in the dependent claims.

**[0031]** The objects described above will be highlighted in greater detail in the description of preferred embodiments of the invention provided here below with reference to the attached drawings, wherein:

- Figures 1 and 2 show the covering device of the invention arranged in two different operating positions, respectively closed and open;
- Figures from 3 to 8 show a further construction variant of the covering device of the invention in different operating positions.

**[0032]** The covering device of the invention is shown in Figures 1 and 2, where it is indicated as a whole by 1.

**[0033]** In the case described herein it is applied to an opening **A** made in the roof of a building.

**[0034]** In a different construction configuration it may also be applied to an opening made in a wall of the building.

**[0035]** According to the invention the covering device comprises, in combination with one another, a cover **2** arranged over the above mentioned opening **A**, a protective shield **3** arranged over the cover **2** and an annular spacer element **6** interposed between the cover **2** and the protective shield **3**, arranged on the perimeter of the cover **2**.

**[0036]** The cover **2** is fixed in relation to the opening **A** to which it is applied, at the level of the perimeter, via fixing means **4** that are preferably but not necessarily clamps.

**[0037]** In this way it is possible to remove the cover, in case of need, by simply removing the fixing means **4**.

**[0038]** The protective shield **3**, on the contrary, moves with a compasses-like motion in relation to the cover **2** via first driving means **7** that comprise an actuator **8** sustained by a fixed bracket **8a** and provided with a moving arm **8b** associated with the protective shield **3**.

**[0039]** As an alternative, as will be described below, the protective shield, instead of moving with a compasses-like movement in relation to the cover, can be moved with a translational movement.

**[0040]** It is evident that, in both cases, the actuator **8** can be of any type, for example electric or pneumatic, and can have any shape and be operated through any suitable system.

**[0041]** When the protective shield **3** is arranged in the closed position shown in Figure 1, it rests on the spacer element **6**.

**[0042]** In particular, the spacer element **6**, as already specified, is of the annular type and is arranged outside the cover **2**.

**[0043]** Furthermore, the spacer element **6** achieves a sealing effect against the perimetral edges of the cover **2** and of the protective shield **3**.

**[0044]** Obviously, the height of the spacer element **6** can vary according to the manufacturer's needs and it will be preferably but not necessarily opaque in order to prevent the passage of light from the sides when the protective shield **3** is closed.

**[0045]** Furthermore, the material used for making it will also be of the heat insulating type, in order to reduce heat exchange with the outside.

**[0046]** According to another embodiment of the invention not illustrated herein, the spacer element can be replaced by other supporting means, provided that they are suited to prevent the passage of light and heat exchange when the covering device is in closed position, and also the protective shield may assume shapes different from the one described.

**[0047]** For example, the protective shield may have a very large surface, such as to contain the cover **2** completely and may rest on a supporting surface arranged on the outer perimeter of the cover **2** itself, at the level of the plane of the fixing means **4**.

**[0048]** The fixing means **4** that connect the cover **2** directly to the perimeter of the opening **A** and the protective shield **3** to the perimeter of a first frame **3a** that rests on the spacer element **6** are preferably but not necessarily of the same type.

**[0049]** The protective shield **3** can be rotated with a compasses-like motion through the operation of the actuator **8** in order to be arranged in any angled position, for example the position shown in Figure 2.

**[0050]** In this way the flow of light entering through the underlying opening **A** can be regulated according to the lighting conditions desired, while this is not possible with the covering device disclosed by the mentioned German patent.

**[0051]** The possibility of rotating the shield to regulate the light flow let in through the opening under the cover

**2** allows the shield to be made even with completely opaque and very resistant materials, even metallic like steel plate and similar materials.

**[0052]** This, on the contrary, is not possible for the covering device described in the mentioned German patent that, having a fixed shield, must necessarily be made of a material suitable for letting the light in.

**[0053]** Therefore, the shield that is the subject of the invention can be made of any material, opaque or not, in any case very resistant and such that when the protective shield **3** is arranged in closed position on the cover **2**, as shown in Figure 1, it protects the underlying cover **2** in case of heavy atmospheric precipitation, like for example severe hail, more effectively than the shield described in the mentioned German patent.

**[0054]** Furthermore, it ensures tightness along the perimeter in contact with the spacer element **6** and also reduces the heat transmittance of the covering device as a whole and therefore also any leaks towards the outside. Therefore, the type of material and the structure of the protective shield **3** and of the spacer element **6** can be differentiated depending on the need, for example the need to give priority to mechanical resistance or heat insulation capacity or darkening capacity or all the three characteristics together.

**[0055]** In the construction form described herein, the cover **2** is fixed and therefore does not allow the room to be aerated.

**[0056]** A further construction variant of the invention is shown in Figures from 3 to 8, where it is indicated as a whole by **30**.

**[0057]** It makes it possible to regulate the position of the cover **32** with respect to the opening **A** and of the protective shield **33** with respect to the cover **32** independently of each other, as second driving means **38** regulate the compasses-like opening of the cover **32** while first driving means **37** regulate the compasses-like opening of the protective shield **33**.

**[0058]** Also in this construction variant the cover **32** is associated with a second frame **32a** that cooperates with a counterframe **32b** fixed to the perimeter of the opening **A** and the protective shield **33** is associated with a first frame **33a**.

**[0059]** In a different embodiment of the invention the protective shield can be without frame and provided with hinges and anchoring means directly fixed to the shield itself.

**[0060]** Even the opening angles of the cover **32** and of the protective shield **33** can be adjusted independently of each other.

**[0061]** In this way, starting for example from the position illustrated in Figure 3, where the cover **32** closes the opening **A** and the protective shield **33** rests on the spacer element **36**, moving only the cover **32** through the second driving means **38** it is possible to pass to the configuration shown in Figure 4, which allows the passage of air into the room, though still ensuring partial protection against light.

**[0062]** Lifting only the protective shield **33** in the position shown in Figure 5, on the other hand, means letting light but not air into the room, as the cover **32** remains closed.

**[0063]** In this position the protective shield **33** substantially performs the function generally performed by a shed opening, as it prevents direct radiation **R** into the room.

**[0064]** When the protective shield **33** is arranged in the configuration shown in Figure 5, it is possible to manoeuvre the cover **32** in such a way as to open it and arrange it in the configuration shown for example in Figure 6, letting also air into the room.

**[0065]** The protective shield **33** can in any case be rotated until reaching an opening angle substantially equal to 180°, as shown in Figure 7, and this in order to ensure an opening angle of substantially 180° also for the cover **32** if the covering device **30** has to operate as a smoke and heat vent.

**[0066]** Also in this construction variant the first driving means **37** comprise an actuator **31** supported by a fixed bracket **31a** and provided with a moving arm **31b** associated with the protective shield **33** while the second driving means **38** comprise a linear actuator **39** supported by a fixed bracket **39a** and provided with a moving rod **39b** having the end **39c** associated with the cover **32**.

**[0067]** As already explained above, even in this construction form the actuator can be of any type.

**[0068]** According to all the embodiments of the covering device of the invention described above, the cover and/or the protective shield can be moved with a compasses-like movement with respect to each other and to the opening to which they are applied. It is evident that the compasses-like movement of the cover and/or of the protective shield is only one of the possible way of moving them and is the most used because it is the easiest and least complicated one. The compasses-like movement can be replaced, for example, by a translational movement according to which the cover and/or the protective shield move following planes that are substantially parallel to each other and to the surface defined by the opening to which they are applied.

**[0069]** Even in the case of a translational movement, this can be achieved using mechanical, electrical or fluid-operated actuators of the type already mentioned, and proper means suited to ensure the sliding movement of the cover and/or the protective shield must be provided.

**[0070]** Furthermore, also in the case of a translational movement, the covering device of the invention maintains all the technical and functional characteristics described above.

**[0071]** On the basis of the description provided above, it is clear that the device that is the subject of the invention, in all the construction variants described, achieves all the set objects.

**[0072]** In particular, it is possible to regulate the aeration of the room and the flow of light let in if the shield and the cover can be moved independently of each other.

**[0073]** Furthermore, it is possible to reduce the heat

transmittance of the covering device of the invention by placing the protective shield over the cover when it is in closed position.

[0074] In case of need, placing the protective shield completely over the cover means protecting the latter from possible damage that may be caused, for example, by heavy hail.

[0075] Obviously, the user will choose for the covering device the shape that among those described is most suitable for its use and, as already explained, the protective shield will be made with specific different materials, depending on whether priority is given to resistance, heat insulation, acoustic insulation, darkening capacity, or two or more of the listed characteristics.

[0076] It should be noted that any existing and installed covering device comprising one or more covers positioned side by side, opening or fixed, by modular skylights or fume vents, can be transformed into the covering device of the invention by simply applying one or more protective shields arranged side by side and placed over the covers.

[0077] In the construction phase, further changes and modifications can be made to the covering device of the invention, which are neither represented nor described herein, but which must all be considered protected by the present patent if they fall within the scope of the following claims.

[0078] In the cases where the technical characteristics illustrated in the claims are followed by references, these have been added only with the aim to facilitate the comprehension of the claims themselves and therefore said references do not have any limiting effect on the degree of protection to be granted to each element they identify only by way of example.

## Claims

1. A roof covering device (1; 30) for openings (A) in buildings, in particular skylights or smoke and heat vents, comprising the following elements, in combination with one another:

- a cover (2; 32) positioned over said opening (A) wherein said cover (2) is fixed in relation to said opening (A) or wherein said cover (32) is movable in relation to said opening (A);
- a protective shield (3; 33) positioned over said cover (2; 32),

wherein it further comprises at least one annular spacer element (6; 36) interposed between said cover (2; 32) and said protective shield (3; 33) and arranged on the perimeter of said cover (2; 32) and wherein said protective shield (3; 33) is movable in relation to said cover (2; 32).

2. Covering device (1) according to claim 1), **characterized in that** the covering device is a skylight, **in that** the cover (2) is fixed in relation to said opening (A) and **in that** said covering device comprises means (4) for fixing said cover (2) to the perimeter of said opening (A) and first driving means (7) suited to move said protective shield (3) in relation to said cover (2).

**3.** Covering device (30) according to claim 1), **characterized in that** said cover (32) is movable in relation to said opening (A) and **in that** it comprises second driving means (38) suited to move said cover (32) in relation to said opening (A) and first driving means (37) suited to move said protective shield (33) in relation to said cover (32).

**4.** Covering device (20; 30) according to claim 3), **characterized in that** it comprises a second frame (32a) associated with the perimeter of said cover (32) and mechanically connected to said second driving means (38), and a counterframe (32b) associated with the perimeter of said opening (A) and cooperating with said second frame (32a).

**5.** Covering device (1; 30) according to any one of claims 2) or 3), **characterized in that** it comprises a first frame (3a, 33a) associated with the perimeter of said protective shield (3; 33) and mechanically connected to said first driving means (17; 37).

**6.** Covering device (1; 30) according to any one of claims 2), 3) or 5), **characterized in that** said first driving means (7; 37) comprise at least one actuator (8; 31) sustained by a fixed bracket (31 a) and provided with a moving arm (31 b) associated with said protective shield (33).

**7.** Covering device (20; 30) according to any one of claims 3) or 4), **characterized in that** said second driving means (38) comprise at least one actuator (39) sustained by a fixed bracket (39a) and provided with a moving rod (39b) whose end (39c) is associated with said cover (32).

**Patentansprüche**

1. Bedachungsvorrichtung (1; 30) für Öffnungen (A) in Gebäuden, insbesondere Oberlichte oder Rauch- und Wärmeabzüge, folgende Elemente in Kombination miteinander umfassend:

- eine oberhalb der besagten Öffnung (A) positionierte Abdeckung (2; 32), wobei die besagte Abdeckung (2) bezüglich der besagten Öffnung (A) fest steht oder wobei die besagte Abdeckung (32) bezüglich der besagten Öffnung (A) beweglich ist;

- einen oberhalb der besagten Abdeckung (2; 32) positionierten Schutzschild (3; 33),

wobei sie des Weiteren wenigstens ein ringförmiges Distanzstück (6; 36) umfasst, das zwischen der besagten Abdeckung (2; 32) und dem besagten Schutzschild (3; 33) eingefügt und um die besagte Abdeckung (2; 32) herum angeordnet ist und wobei der besagte Schutzschild (3; 33) bezüglich der besagten Abdeckung (2; 32) beweglich ist.

2. Bedachungsvorrichtung (1) gemäß Patentanspruch 1), **dadurch gekennzeichnet, dass** die Bedachungsvorrichtung ein Oberlicht ist, dass die Abdeckung (2) bezüglich der besagten Öffnung (A) fest steht und dass die besagte Bedachungsvorrichtung Mittel (4) zur Befestigung der besagten Abdeckung (2) am Umfang der besagten Öffnung (A) umfasst sowie erste Antriebsmittel (7), die geeignet sind, den besagten Schutzschild (3) bezüglich der besagten Abdeckung (2) zu bewegen.
3. Bedachungsvorrichtung (30) gemäß Patentanspruch 1), **dadurch gekennzeichnet, dass** die besagte Abdeckung (32) bezüglich der besagten Öffnung (A) beweglich ist und dass sie zweite Antriebsmittel (38) umfasst, um die besagte Abdeckung (32) bezüglich der besagten Öffnung (A) zu bewegen, sowie erste Antriebsmittel (37) zur Bewegung des besagten Schutzschields (33) bezüglich der besagten Abdeckung (32).
4. Bedachungsvorrichtung (20; 30) gemäß Patentanspruch 3), **dadurch gekennzeichnet, dass** sie einen zweiten Rahmen (32a) umfasst, der dem Umfang der besagten Abdeckung (32) zugeordnet und mechanisch mit den besagten zweiten Antriebsmitteln (38) verbunden ist, sowie einen Gegenrahmen (32b), der dem Umfang der besagten Öffnung (A) zugeordnet ist und mit dem besagten zweiten Rahmen (32a) zusammenwirkt.
5. Bedachungsvorrichtung (1 ; 30) gemäß eines jeden der Patentansprüche 2) oder 3), **dadurch gekennzeichnet, dass** sie einen ersten Rahmen (3a, 33a) umfasst, der dem Umfang des besagten Schutzschields (3; 33) zugeordnet und mechanisch mit den besagten ersten Antriebsmitteln (17; 37) verbunden ist.
6. Bedachungsvorrichtung (1; 30) gemäß eines jeden der Patentansprüche 2), 3) oder 5), **dadurch gekennzeichnet, dass** die besagten ersten Antriebsmittel (7; 37) wenigstens einen Aktuator (8; 31) umfassen, der durch eine feststehende Halterung (31 a) getragen wird und mit einem sich bewegenden Arm (31 b) versehen ist, der dem besagten Schutzschild (33) zugeordnet ist.

7. Bedachungsvorrichtung (20; 30) gemäß eines jeden der Patentansprüche 3) oder 4), **dadurch gekennzeichnet, dass** die besagten zweiten Antriebsmittel (38) wenigstens einen Aktuator (39) umfassen, der durch eine feststehende Halterung (39a) getragen wird und mit einer sich bewegenden Stange (39b) versehen ist, deren Ende (39c) der besagten Abdeckung (32) zugeordnet ist.

## Revendications

1. Dispositif de couverture de toits (1 ; 30) pour ouvertures (A) réalisées sur bâtiments, en particulier en lucarnes ou événements de fumée et de chaleur, comprenant les éléments suivants, en combinaison entre eux:
  - un couvercle (2; 32) disposé au-dessus de ladite ouverture (A) où ledit couvercle (2) est fixé par rapport à ladite ouverture (A) ou où ledit couvercle (32) est mobile par rapport à ladite ouverture (A);
  - un bouclier de protection (3; 33) disposé au-dessus dudit couvercle (2; 32), où il comprend également au moins une pièce intercalaire annulaire (6; 36) interposée entre ledit couvercle (2; 32) et ledit bouclier de protection (3; 33) et disposée sur le périmètre dudit couvercle (2; 32) et où ledit bouclier de protection (3; 33) est mobile par rapport audit couvercle (2; 32).
2. Dispositif de couverture (1) selon la revendication 1), **caractérisé en ce que** le dispositif de couverture est une lucarne, **en ce que** le couvercle (2) est fixe par rapport à ladite ouverture (A) et **en ce que** ledit dispositif de couverture comprend des moyens (4) aptes à fixer ledit couvercle (2) au périmètre de ladite ouverture (A) et de premiers moyens de déplacement (7) indiqués pour déplacer ledit bouclier de protection (3) par rapport audit couvercle (2).
3. Dispositif de couverture (30) selon la revendication 1), **caractérisé en ce que** ledit couvercle (32) est mobile par rapport à ladite ouverture (A) et **en ce qu'il** comprend de deuxièmes moyens de déplacement (38) aptes à déplacer ledit couvercle (32) par rapport à ladite ouverture (A) et de premiers moyens de déplacement (37) aptes à déplacer ledit bouclier de protection (33) par rapport audit couvercle (32).
4. Dispositif de couverture (20; 30) selon la revendication 3), **caractérisé en ce qu'il** comprend un deuxième châssis (32a) associé au périmètre dudit couvercle (32) est relié mécaniquement auxdits deuxièmes moyens de déplacement (38) et un contre-châssis (32b) associé au périmètre de ladite ouverture (A) et coopérant avec ledit deuxième châssis (32a).

5. Dispositif de couverture (1; 30) selon l'une quelconque des revendications 2) ou 3), **caractérisé en ce qu'il** comprend un premier châssis (3a, 33a) associé au périmètre dudit bouclier de protection (3; 33) et relié mécaniquement auxdits premiers moyens d'actionnement (17 ; 37). 5
6. Dispositif de couverture (1; 30) selon l'une quelconque des revendications 2), 3), ou 5), **caractérisé en ce que** lesdits premiers moyens de déplacement (7; 37) comprennent au moins un actionneur (8; 31) supporté par une bride fixe (31 a) et doté d'un bras mobile (31 b) associé audit bouclier de protection (33). 10  
15
7. Dispositif de couverture (20; 30) selon l'une quelconque des revendications 3), ou 4), **caractérisé en ce que** lesdits deuxièmes moyens de déplacement (38) comprennent au moins un actionneur (39) supporté par une bride fixe (39a) et doté d'une tige mobile (39b) dont l'extrémité (39c) est associé audit couvercle (32). 20  
25  
30  
35  
40  
45  
50  
55

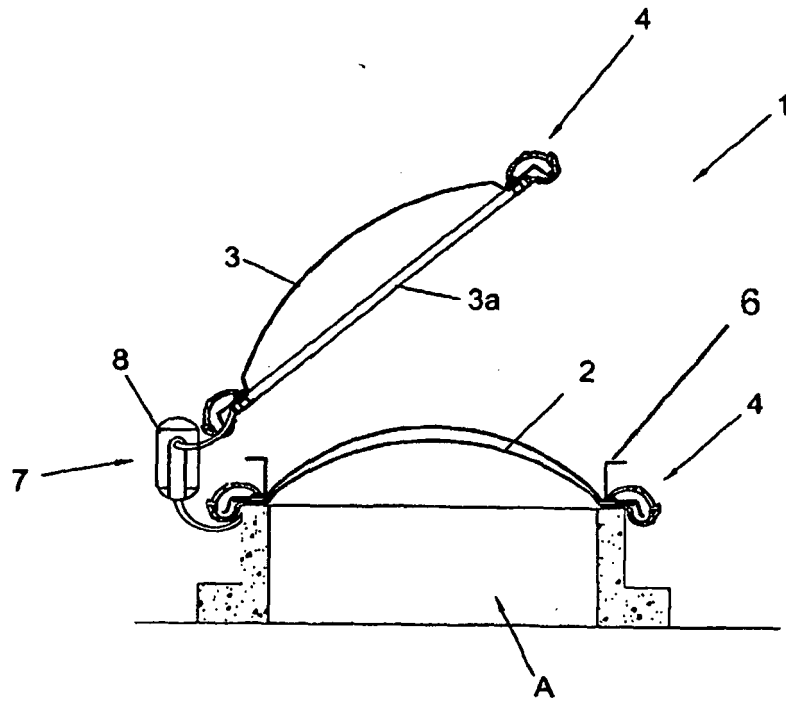
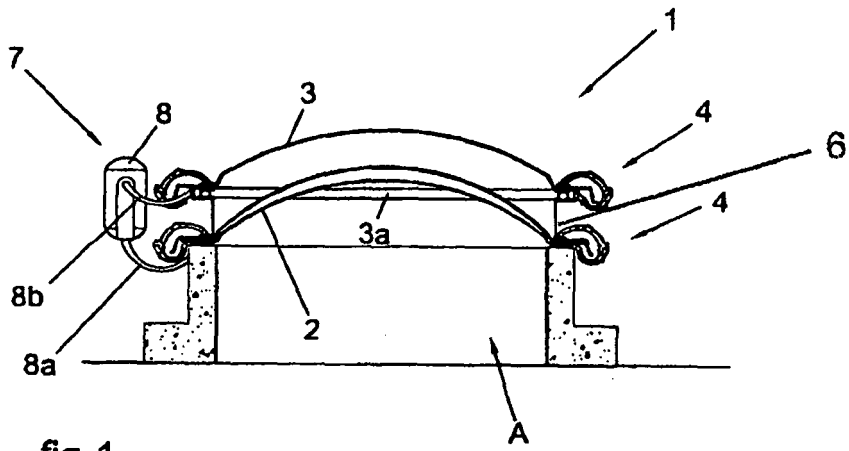

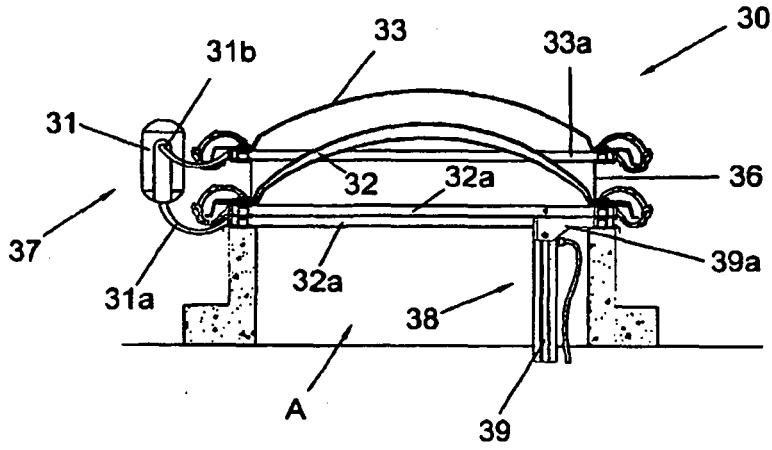

fig. 3

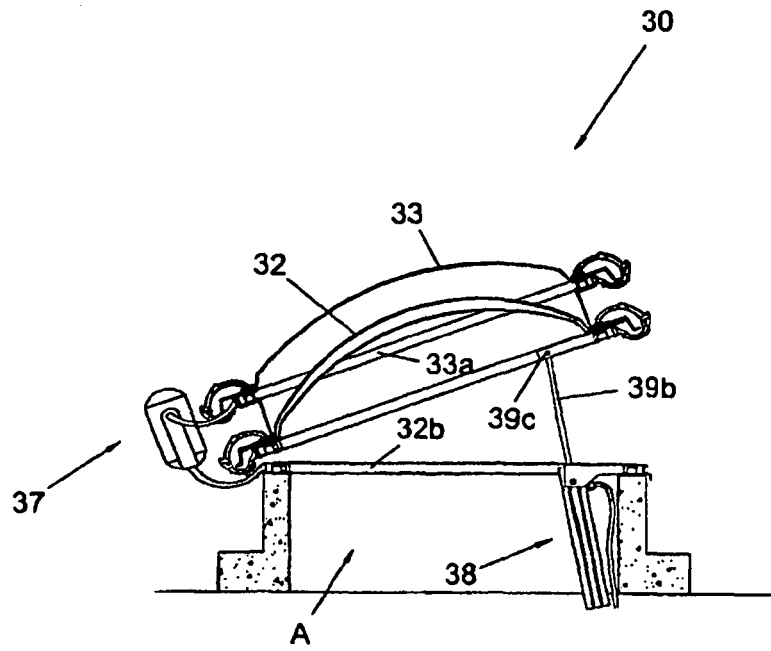

fig. 4

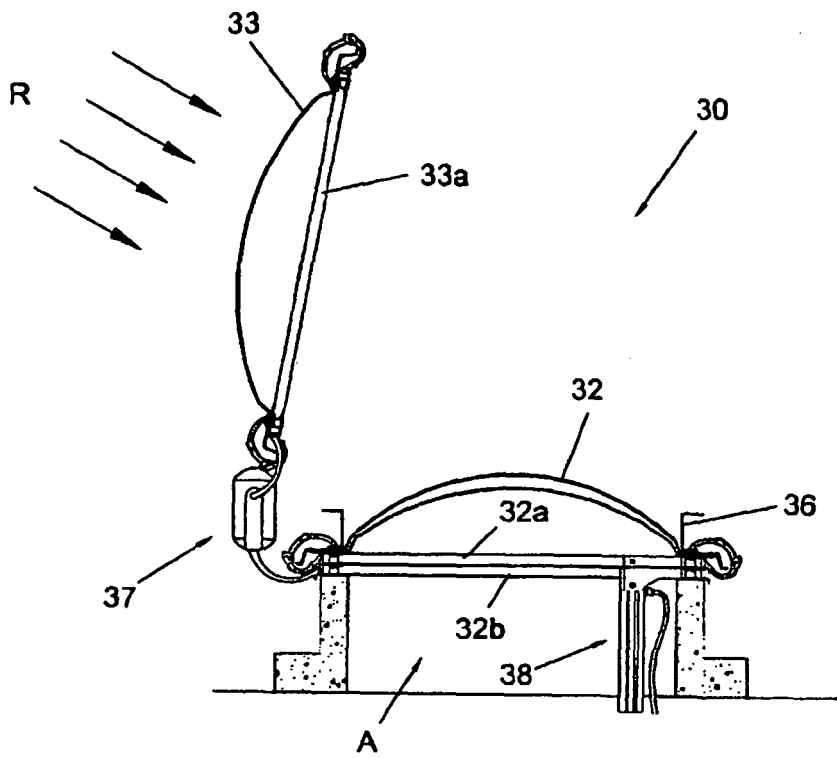

fig. 5

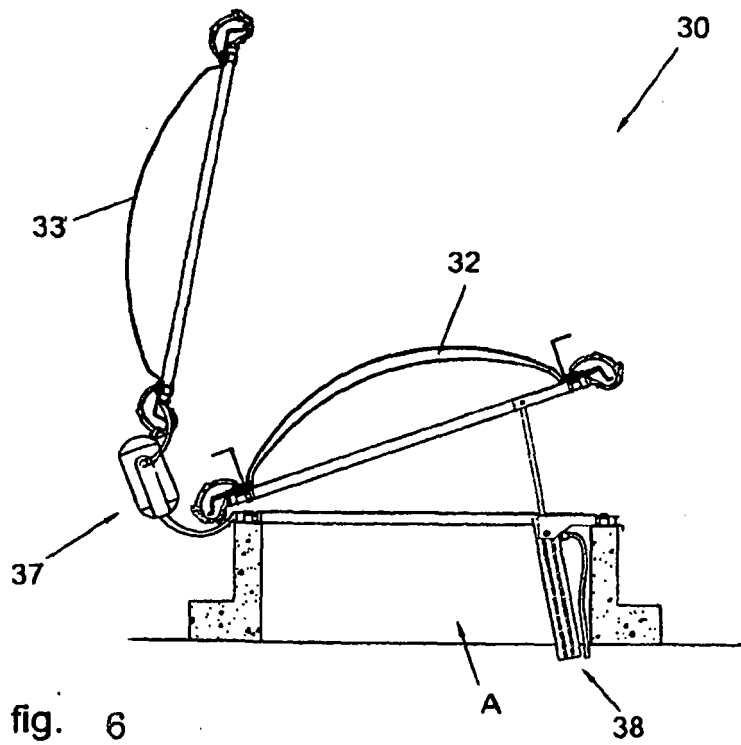
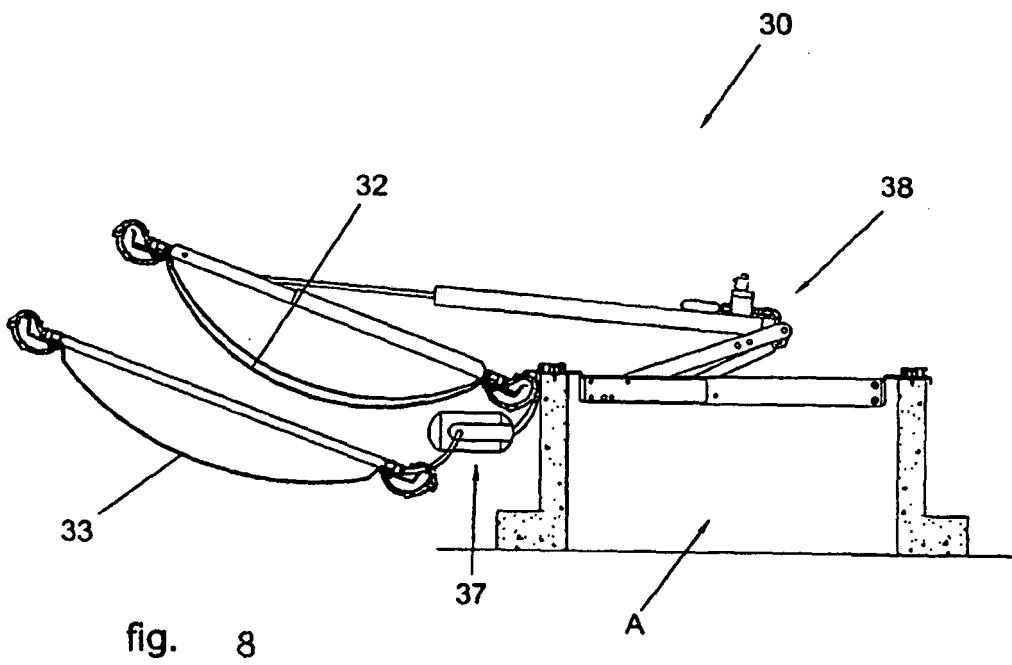
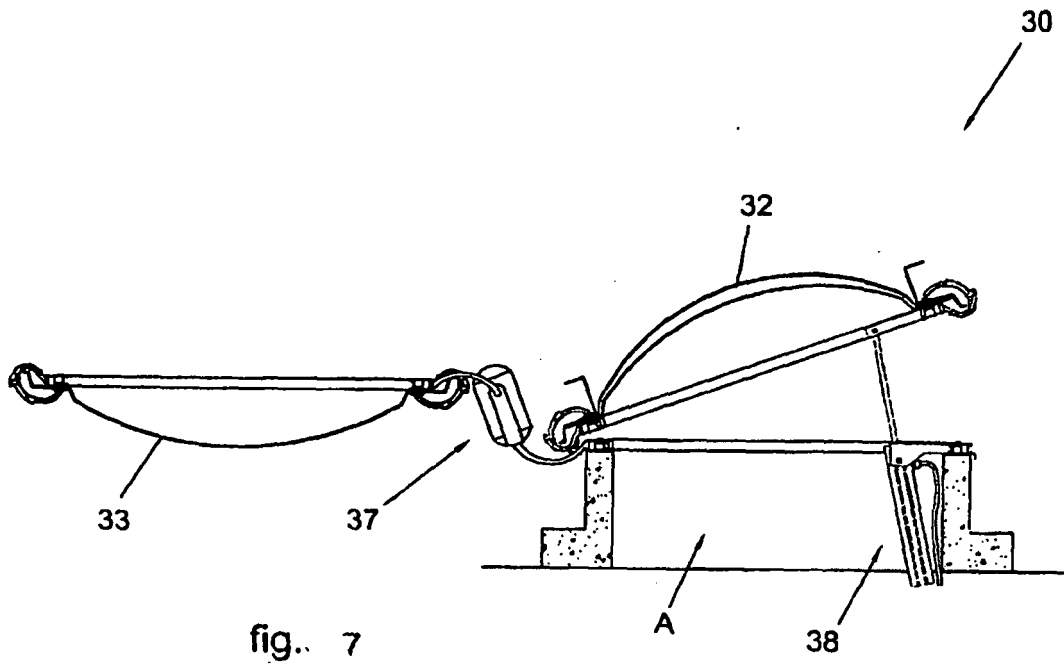

fig. 6



**REFERENCES CITED IN THE DESCRIPTION**

*This list of references cited by the applicant is for the reader's convenience only. It does not form part of the European patent document. Even though great care has been taken in compiling the references, errors or omissions cannot be excluded and the EPO disclaims all liability in this regard.*

**Patent documents cited in the description**

- WO 0159232 A1 [0007]
- DE 10138731 A7 [0008]
- DE 1290325 [0016]